

THIS DRAWING IS UNPUBLISHED. RELEASED FOR PUBLICATION JAN ,2006.

© COPYRIGHT 2006 BY TYCO ELECTRONICS CORPORATION. ALL RIGHTS RESERVED.

LOC	DIST	REVISIONS					
E	B	P	LTR	DESCRIPTION	DATE	DWN	APVD
		C		ECR-05-017969	12JAN06	JMS	FWK

NOTES:

- 1 PACK IN ACCORDANCE WITH AMP SPEC 107-3275
- 2 100 TRAY PACK IN ACCORDANCE WITH AMP SPEC 107-3275
- 3 Ag PLATING
- 4 THIS ITEM MUST BE WHITE

- 5 ELECTRICAL CHARACTERISTICS
- | | |
|-------------------------------|----------------------------|
| FREQUENCY RANGE: | DC - 1 GHz |
| NOMINAL IMPEDANCE: | 75 Ohm |
| INSULATION RESISTANCE: | 5000 MOhm |
| WORKING VOLTAGE: | 500 Volts RMS at Sea Level |
| DIELECTRIC WITHSTAND VOLTAGE: | 1500 Volts RMS Max |
| CONTACT RESISTANCE: | |
| CENTRE CONTACT: | 1.50 mOhm Max |
| OUTER CONTACT: | 0.20 mOhm Max |
| INSERTION LOSS xdb: | TBA |
- 6 MECHANICAL CHARACTERISTICS
- | | |
|---------------------------|----------------|
| COUPLING RETENTION FORCE: | 445N |
| CABLE RETENTION FORCE: | N/A |
| DURABILITY: | 500 Cycles Min |
- 7 ENVIRONMENTAL CHARACTERISTICS
- | | |
|------------------------|------------------|
| OPERATING TEMPERATURE: | -65 to +165 DegC |
|------------------------|------------------|

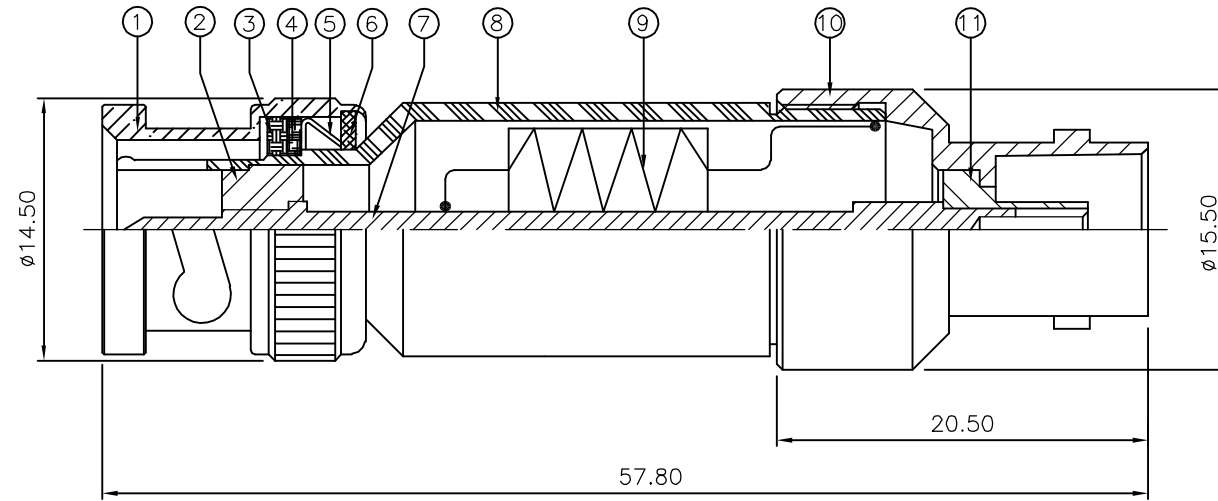

QTY	QTY PER ASSY	MATERIAL	DESCRIPTION	ITEM
1	1	PTFE	INSULATION	11
1	1	BRASS	BODY II	10
1	1	2W-75 OHM	RESISTOR	9
1	1	BRASS	BODY I	8
1	1	BRASS	CONTACT	7
1	1	BRASS	WASHER	6
1	1	SPRING STEEL	SPRING	5
1	1	BRASS	RETAINING RING	4
1	1	SILICON RUBBER	GASKET	3
1	1	PTFE	INSULATION	2
1	1	BRASS	SHELL	1
6--0	1--0			

QUANTITY PER ASSY		PARTS LIST	
DWN J.SANDWELL 12JAN06		Tyco Electronics Corporation	
CHK S.PARLOW 12JAN06		Bideford EX39 4HE	
APVD F.WHEELER-KING 12JAN06		NAME	
PRODUCT SPEC		BNC THROUGH TERMINATION 75 OHM	
APPLICATION SPEC		-	
SIZE	CAGE CODE	DRAWING NO	RESTRICTED TO
A3	00779	C-1337492	-
CUSTOMER DRAWING		SCALE	SHEET 1 OF 1 REV C
		NTS	

THIS DRAWING IS A CONTROLLED DOCUMENT.	
DIMENSIONS: mm	TOLERANCES UNLESS OTHERWISE SPECIFIED:
	0 PLC ± -
	1 PLC ± -
	2 PLC ± -
	3 PLC ± -
	4 PLC ± -
	ANGLES ± -
MATERIAL SEE TABLE	FINISH -