

RIGHT ANGLE JACK RECEPTACLE FOR PCB

R141.665.000

SOLDER LEGS

Series : BNC

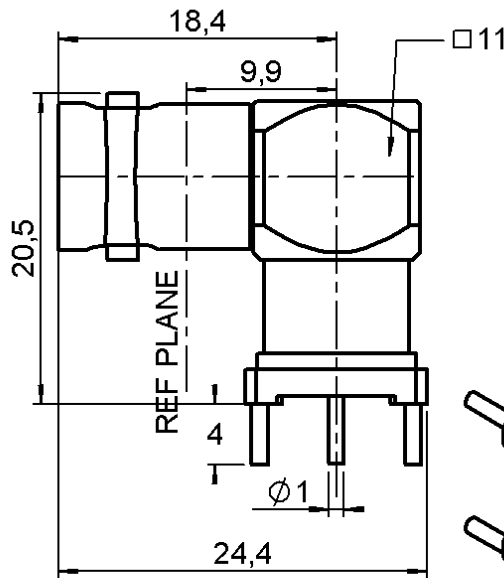
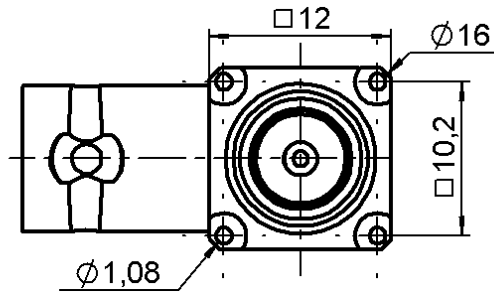

PANEL CUT OUT

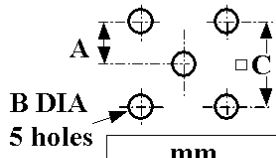

	mm	
	Maxi	mini
A	5.13	5.03
B	1.3	1.2
C	10.21	10.11

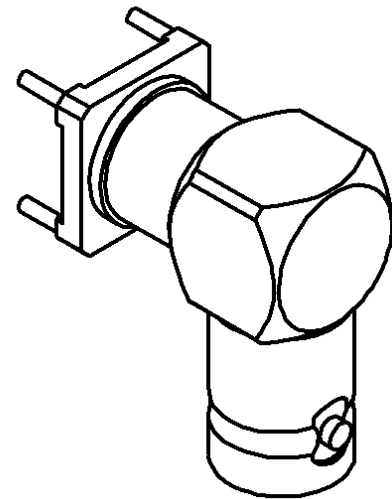
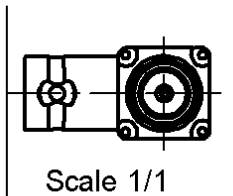

All dimensions are in mm.

COMPONENTS	MATERIALS	PLATINGS (µm)
BODY	BRASS	NICKEL 2
CENTER CONTACT	BERYLLIUM COPPER	GOLD 0.5 OVER NICKEL 2
OUTER CONTACT	-	-
INSULATOR	PTFE	-
GASKET	-	-
OTHERS PARTS	-	-
-	-	-
-	-	-

Issue : 9913 D

In the effort to improve our products, we reserve the right to make changes judged to be necessary.



RIGHT ANGLE JACK RECEPTACLE FOR PCB

R141.665.000

SOLDER LEGS

Series : **BNC**

PACKAGING

SPECIFICATION

Standard	Unit	Other
100	'W' option	Contact us

ELECTRICAL CHARACTERISTICS

ENVIRONMENTAL

Impedance		50 Ω
Frequency		0-4 GHz
VSWR	1.06 +	0.006 x F(GHz) Maxi
Insertion loss		.025* √F(GHz) dB Maxi
RF leakage	- (57 - F(GHz)) dB Maxi
Voltage rating		500 Veff Maxi
Dielectric withstanding voltage		1500 Veff mini
Insulation resistance		5000 MΩ mini

Operating temperature	-65/+165 ° C
Hermetic seal	NA Atm.cm3/s
Panel leakage	NA

OTHERS CHARACTERISTICS

Assembly instruction **NA**

Others :

* Coaxial Transmission Line Only

MECHANICAL CHARACTERISTICS

Center contact retention	
Axial force – Mating end	18 N mini
Axial force – Opposite end	18 N mini
Torque	2.8 N.cm mini
Recommended torque	
Mating	NA N.cm
Panel nut	NA N.cm
Mating life	500 Cycles mini
Weight	17.000 g

Issue : 9913 D

In the effort to improve our products, we reserve the right to make changes judged to be necessary.

