

**RIGHT ANGLE JACK RECEPTACLE FOR PCB
SOLDER LEGS**

R141.665.161

Series : BNC-COM

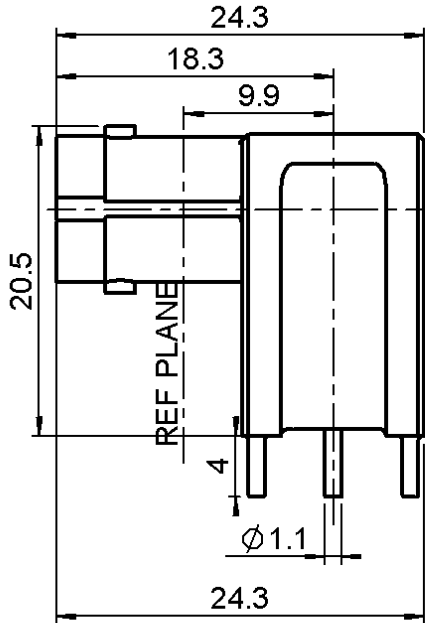
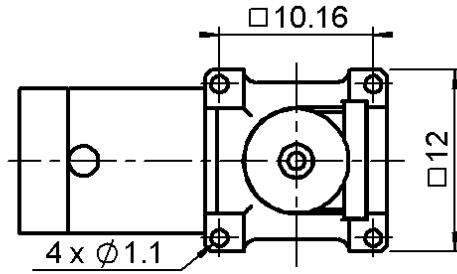

PANEL CUT OUT

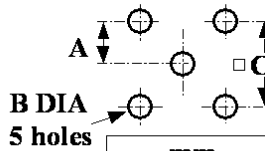

	mm	
	Maxi	mini
A	5.105	5.055
B	1.4	1.2
C	10.21	10.11

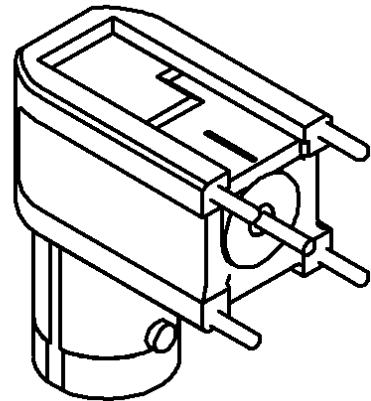
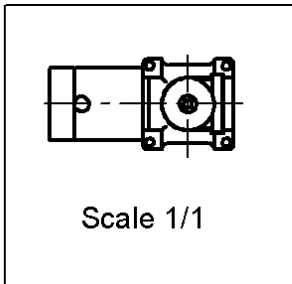

All dimensions are in mm.

COMPONENTS	MATERIALS	PLATINGS (µm)
BODY	ZAMAK	NICKEL 2
CENTER CONTACT	BRASS	GOLD 0.2 OVER NICKEL 2
OUTER CONTACT	-	-
INSULATOR	PTFE	-
GASKET	-	-
OTHERS PARTS	-	-
.	.	.
.	.	.

Issue : 0412 F

In the effort to improve our products, we reserve the right to make changes judged to be necessary.



RIGHT ANGLE JACK RECEPTACLE FOR PCB

R141.665.161

SOLDER LEGS

Series : **BNC-COM**

PACKAGING

SPECIFICATION

Standard	Unit	Other
100	'W' option	Contact us

ELECTRICAL CHARACTERISTICS

ENVIRONMENTAL

Impedance		50 Ω
Frequency		0-1.5 GHz
VSWR	1.08 +	0.006 x F(GHz) Maxi
Insertion loss		.035* √F(GHz) dB Maxi
RF leakage	- (57 - F(GHz)) dB Maxi
Voltage rating		500 Veff Maxi
Dielectric withstanding voltage		1500 Veff mini
Insulation resistance		5000 MΩ mini

Operating temperature	-35/+70 ° C
Hermetic seal	NA Atm.cm3/s
Panel leakage	NA

OTHERS CHARACTERISTICS

Assembly instruction **NA**

Others :

* Coaxial Transmission Line Only

MECHANICAL CHARACTERISTICS

Center contact retention		
Axial force – Mating end	15	N mini
Axial force – Opposite end	15	N mini
Torque	NA	N.cm mini
Recommended torque		
Mating	NA	N.cm
Panel nut	NA	N.cm
Mating life	100	Cycles mini
Weight	13.500	g

Issue : 0412 F

In the effort to improve our products, we reserve the right to make changes judged to be necessary.

