

Assembly instructions: 51 P1

Series: BNC; TNC

**Straight connector
for flexible cable**

Cable entry:

**Center contact - crimp
Braid - crimp**

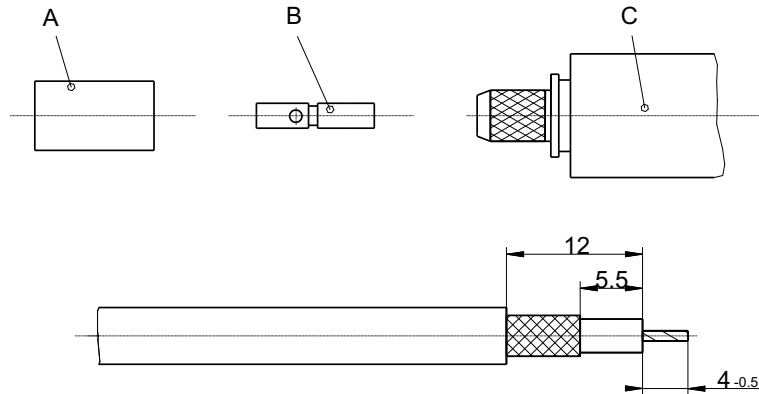

1. Prepare the cable according to the diagram.

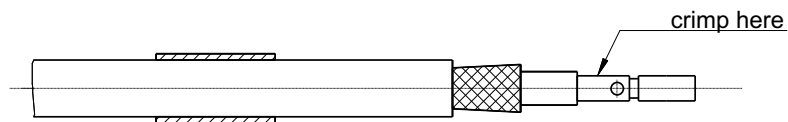

2. Slide ferrule "A" onto the cable.
3. Push center pin "B" over the inner conductor of the cable up to the dielectric and crimp it.*)
4. Splay out the braid.

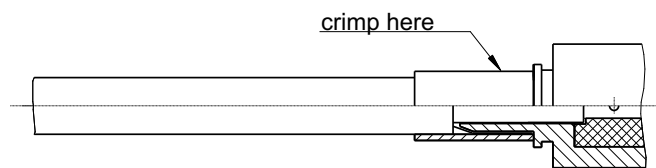

5. Insert the prepared cable into the connector body "C" until the center pin engages perceptibly. Ensure that the braid covers the knurled connector end.
6. Slide ferrule "A" over the braid up to the feed-through body and crimp as close to the feed-through body as possible.*)

*) For the crimping die part-nr. please consult the relevant customer drawing.

für diese technische Unterlage bezahlen wir uns alle Rechte vor (DIN 34)

				Rosenberger Hochfrequenztechnik 84526 Tittmoning				Tools: Stripping tool Crimp tool 11 W 150-000 or 11 W 100-000
b	96-0113	21.03.96	KoBra	Bearb.	11.03.96	Krautenb.Sa.	M 2:1	
a	CAD-MTP	11.03.96	Kra.Sa.	Gepr.			Blatt 1/1	
Zust.	Änderung	Datum	Name					