

TOOL NUMBER	HANDLE COLOR		CONTACT SIZE	AWG SIZE
	INSRN	EXTR		
91067-1	Green	White	22	22 - 28
91067-2	Red	White	20 DM & 20 DF	20 - 24

Figure 1

1. INTRODUCTION

This instruction sheet covers Insertion/ Extraction Tools 91067-1 and 91067-2. These tools are designed for the Type XVII contacts, sizes 22 and 20, used in AMPLIMITE* High Density (HD) Connectors. Read this material thoroughly before using the tools.

Insertion/Extraction Tool 91067-3, previously listed on this instruction sheet, has been superseded by Insertion/Extraction Tool 91285-1. For information on this tool, refer to Instruction Sheet 408-9404.

NOTE  Dimensions on this sheet are in millimeters [with inch equivalents in brackets]. Figures and illustrations are for identification only, and are not drawn to scale.

Reasons for reissue are provided in Section 5, REVISION SUMMARY.

2. DESCRIPTION

Each tool handle consists of two color-coded halves. The white half features a metal extraction tip, and the other half (red or green) features a metal insertion tip. See Figure 1.

Contact Insertion

The tool number and contact size are stamped on the white half, and the "AMP" marking is molded on the other half (red or green). See Figure 3.

3. INSERTION/EXTRACTION PROCEDURES

3.1. Inserting Contacts (Figure 1)

1. Position tool handle between thumb and finger tips of one hand, then lace wire over wire slot and under thumb.
2. Position forefinger under tool tip and, while applying light pressure on the wire, slide your thumb over the wire until the tip spreads and the wire seats in the tip.
3. Reposition tool between thumb and finger tips.



It is important that you hold the tool between your thumb and finger tips to prevent the possibility of injury. Do not hold tool with unused tip (end) toward or against palm of your hand.

4. Slide tool tip over contact wire barrel until it butts against contact shoulder.
5. Align contact with back of cavity and push the contact straight in until bottomed.
6. Remove the tool, then pull back *lightly* on the wire to be sure the contact is locked in the cavity.

3.2. Extracting Contacts (Figure 2)

1. Align wire of contact to be removed with wire slot of tool, then grip tool handle between thumb and finger tips of one hand.
2. Position forefinger under tip of tool and, while applying light pressure on the wire, slide your thumb over the wire until the tip spreads and the wire is seated in tool tip.
3. Reposition tool handle between thumb and finger tips.



It is important that you hold the tool between your thumb and finger tips to prevent the possibility of injury. Do not hold tool with unused tip (end) toward or against palm of your hand.

4. Slide tool tip along the wire and straight into the cavity until it is bottomed.
5. Hold the wire *securely* against the tool handle serrations and pull back lightly to extract the contact.

If the contact does not come out easily, reseat the tip in the cavity and repeat Step 5.

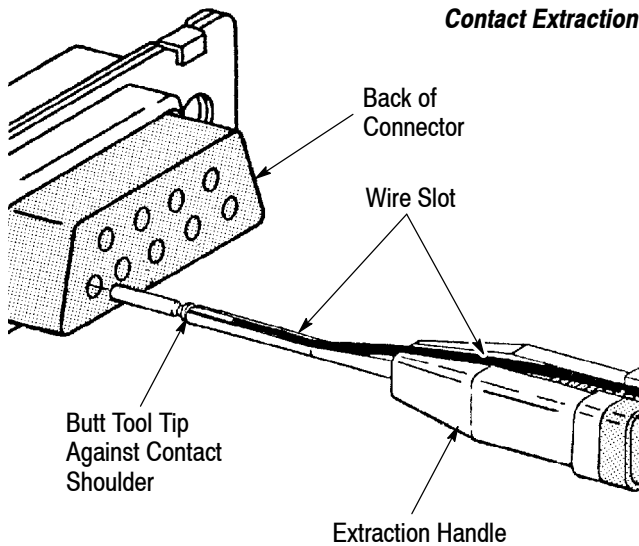

Figure 2

4. MAINTENANCE AND INSPECTION

To ensure proper operation, the tool should conform to the dimensions in Figure 3. It is recommended that the tool be inspected immediately on its arrival and at regularly scheduled intervals. The tool is not repairable and should be replaced when worn or damaged. It is recommended that the tool be stored in a clean, dry place and cleaned with a soft, lint-free cloth.

Additional tools can be purchased from:

CUSTOMER SERVICE (38-35)
 TYCO ELECTRONICS CORPORATION
 P.O. BOX 3608
 HARRISBURG, PA 17105-3608

5. REVISION SUMMARY

Since the previous release of this sheet, the following changes were made:

- Updated document to corporate requirements.

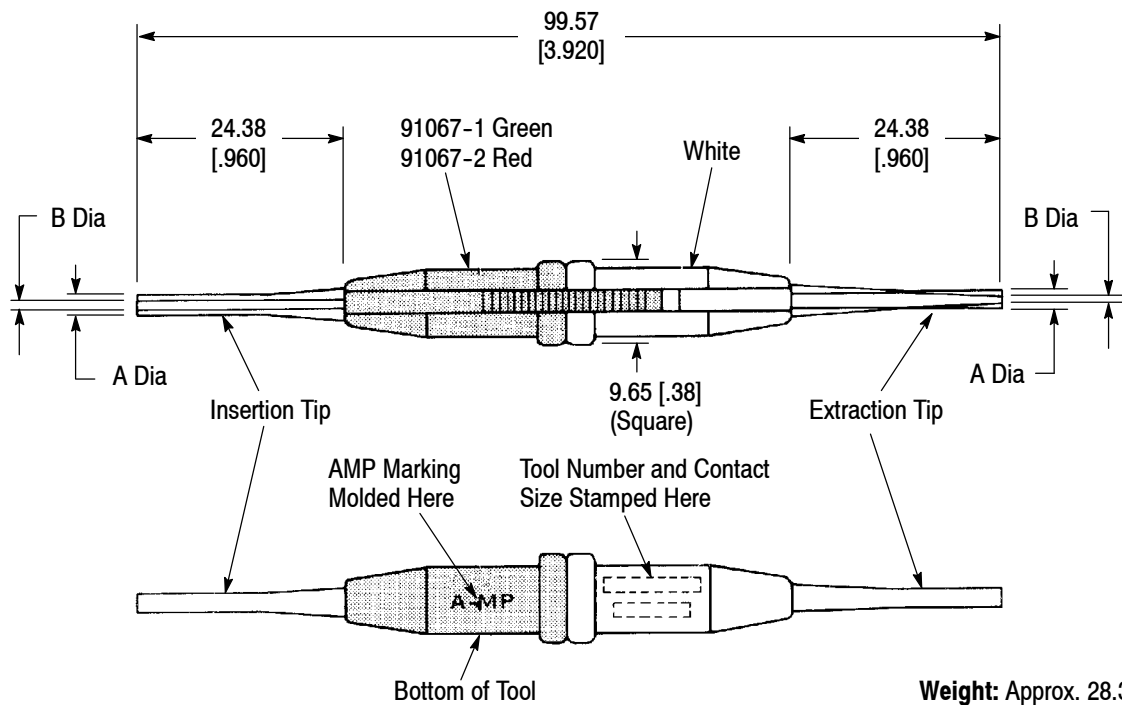

Weight: Approx. 28.3 g [1 oz.]

TOOL NUMBER	DIM.		HANDLE COLOR		PRODUCT DESIGNED FOR	AWG SIZE
	A	B	INSRN	EXTR		
91067-1	1.65 [.065]	0.89 [.035]	Green	White	AMPLIMITE Contacts Size 22	22 - 28
91067-2	2.16 [.085]	1.65 [.065]	Red	White	AMPLIMITE Contacts Size 20 DM and 20 DF (With Insul Max of 1.73 [.068])	20 - 24

Figure 3