

COMMUNICATIONS, DATA, CONSUMER DIVISION

D-Subminiatures Connectors and accessories

WEB Product Catalogue
(2006 October revision)

D-Sub

FCI: Setting the standard for connectors

With operations in 30 countries, FCI is a leading manufacturer of connectors.

Our 13,500 employees are committed to providing customers with high-quality, innovative products for a wide range of consumer and industrial applications.

**For more information:
www.fciconnect.com**

Introduction

The products are marketed through the international sales organisation of FCI.

FCI D-Sub product lines are present in high technology areas:

- communications,
- data,
- consumer,
- industrial,
- military.

Many styles of termination and performance levels are available and a large choice of accessories completes the range.

Our continuous improvement programme is focused on:

- Manufacturing process control,
- High quality level (ISO 9001 approved),
- Innovation

FCI is an excellent partner for your connection needs.

 **Check preferred and standard solutions !**

D-Sub





Index	page
D-Sub overview	
• Selector Guide	4-5
• General Characteristics	6-7
DELTA D	
• Right angle solder DELTA D	8-9
• Straight solder DELTA D	10-11
• Straight press-fit DELTA D	12-13
• Right angle press-fit DELTA D	14-15
COMPACT D - High density	
• High density solder	16-17
• High density press-fit	18-19
Mixed power DW series	
• General characteristics	20-23
• Mixed power DW series - solder	24-25
• Mixed power DW series - cable version	26-27
• DW series Power solder and crimp	28
• DELTA D Power right angle solder	29
• DW series Full power right angle and straight press-fit	30-31
D / 8656 / 8657 / DP series	
• D series	32-33
• 8656 series crimp contacts and cable connectors	34-35
• 8657 series IDC for flat cable	36-37
• DP series machined contacts D-Sub	38-39
Military products	
• DM series HE 501	40-41
• DM series HE 508	42-43
• DMW series HE 507 - Full and mixed power	44-47
Accessories	
• D-Sub Accessories	48-57
• D-Sub Technical characteristics and dimensions	58-62

Nota : All dimensions in mm

D-Sub Selector Guide

PCB applications

Standard applications

		Pages	
Signal standard density	Right angle	• Solder : Delta D 8	
		• Press-fit : Delta D 14	
	Straight	• Solder : Delta D 10	
• Press-fit : Delta D 12			
		D series also available, see catalogue 28	
Signal high density		• Solder 16	
		• Press-fit 18	
Power	Right angle	• Solder - Full & mixed power : Delta D 29	
		DW series 24	
	• Press-fit - Full power : DW series 30		
Straight		• Solder - Full & mixed power : DW series... 24	
		• Press-fit - Full power 30	

Demanding applications : machined signal contacts

Signal	<ul style="list-style-type: none"> • Right angle solder : DP series • Wire-wrap : DP series • Straight solder : DP series 38 	
--------	---	---



Severe environment applications

Signal	HE 501 compliant standard	• Right angle : DM series	
		• Straight : DM series 40	
	HE 508 compliant high temperature	• Right angle : DM series	
		• Straight : DM series 42	
Power	HE 507 compliant	• Right angle : DMW series	
		• Straight : DMW series 44	

D-Sub Selector Guide

Cable applications

Standard applications

		Pages	
Signal	• Solder bucket : D series	32	
	• Crimp : 8656 series	34	
	• IDC : 8657 series	36	
Power	• Solder bucket : DW series	26	
	• Crimp : DW series	26	

Demanding applications : machined signal contacts

Signal	• Solder bucket : DP series	38	
--------	-----------------------------------	----	---

Accessories

Hoods	• Plastic	}	48	
	• Metallized			
	• Metallic		48	
	Others hoods		48	
Locking devices		53	
Other accessories		56	

D-Sub

Technical characteristics

PC BOARD TERMINATION					
SERIES		Delta D Solder for PC Board	Delta D Press-fit	Mixed Power DW	D
ENVIRONMENTAL CHARACTERISTICS	Operating temperature range	-55°C to 125°C	-55°C to 125°C	-55°C to 125°C	-55°C to 125°C
	Salt spray	24 hours	24 hours	24 hours	24 hours
	Damp heat	21 days	21 days	21 days	21 days
	Proof Version	no	no	no	no
NORMES AND APPROVALS	UL 94 VO	E 118235 (R)	E 118235 (R)	E 118235 (R)	E 118235 (R)
	NFC 93425			compliance with HE 507	
	DIN 41652	in compliance with	in compliance with	—	in compliance with
	Others	LNZ 4404		—	
MATERIAL	Shell	Steel	Steel	Steel	Steel
	Insulator	Thermoplastic	Thermoplastic	Thermoplastic	Thermoplastic
	Contacts	Copper alloy	Copper alloy	Copper alloy	Copper alloy
STANDARD PLATING	Shell	Tin	Tin	Tin	Tin
	Contact	active area termination area	Gold over Nickel Tin over Nickel	Gold over Nickel Tin over Nickel	Gold over Nickel Tin over Nickel
ELECTRICAL CHARACTERISTICS	Max current rating per contact	5 A	5 A	7.5 A (signal contact) 40 A (power contact)	5 A
	Dielectric withstanding voltage (DWW)	1000 V.r.m.s.	1000 V.r.m.s.	1000 V.r.m.s.	1000 V.r.m.s.
	Rated voltage V.r.m.s. 50 Hz	300 V.r.m.s.	300 V.r.m.s.	300 V.r.m.s.	300 V.r.m.s.
	Insulation resistance	≥ 5000 MΩ	≥ 5000 MΩ	≥ 5000 MΩ	≥ 5000 MΩ
	Contact resistance	≤ 10 mΩ *	≤ 10 mΩ *	≤ 7.3 mΩ	≤ 10 mΩ *
	Insertion / Extraction force per contact (N)	5N Max. / 0.3N min.	5N Max. / 0.3N min.	5N Max. / 0.3N min.	5N Max. / 0.3N min.
MECHANICAL AND DIMENSIONAL CHARACTERISTICS	Mating / Unmating cycles	200 min.	200 min.	500 min.	200 min.
	Contact diameter on active area	1 mm	1 mm	3.6 mm (power contact) 1 mm (signal contact)	1 mm
	Removable contacts	no	no	yes (cable)	no
	Size			AWG 20 Max. (signal contact) other see page 23	AWG 20 Max.
WIRE	Max diameter on insulator			—	2.1 mm
	LAYOUT	Number of contacts	9, 15, 25, 37, 50* Male and Female	9, 15, 25, 37, 50 Male and Female	9, 15, 25, 37, 50* Male and Female

* Straight version only

D-Sub

PC BOARD TERMINATION					
8656	8657	Compact D High density	DP	DM HE 501 / HE 508	DMW HE 507
-55°C to 105°C	-55°C to 125°C	-55°C to 125°C	-55°C to 125°C	-55°C to 125°C / -55°C to 155°C	-55°C to 125°C
24 hours	24 hours	24 hours	24 hours	48 hours	48 hours
21 days	21 days	21 days	21 days	56 days	56 days
no	no	no	no	no	no
E 118235 (R)	E 118235 (R)	E 118235 (R)	E 118235 (R)	E 118235 (R)	E 118235 (R)
in compliance with	in compliance with		in compliance with	—	—
in compliance with	in compliance with		in compliance with	—	—
				LNZ 4404	
Steel	Steel	Steel	Steel	Steel	Steel
Thermoplastic	Thermoplastic	Thermoplastic	Thermoplastic	Thermoplastic / Thermoset	Thermoplastic / Thermoset
Copper alloy	Copper alloy	Copper alloy	Copper alloy	Copper alloy	Copper alloy
Tin	Tin	Tin	Tin	Cadmium Zinc Chrom3 (RoHS)	Cadmium Zinc Chrom3 (RoHS)
Gold over Nickel	Gold over Nickel	Gold over Nickel	Gold over Nickel	Gold over Nickel	Gold over Nickel
Tin over Nickel	Tin over Nickel	Tin over Nickel	Tin over Nickel	Tin / Gold over Nickel	Tin / Gold over Nickel
5 A	1.5 A	2.5 A	7.5 A	7.5 A	7.5 A (signal contact) 40 A (power contact)
1000 V.r.m.s.	1000 V.r.m.s.	1000 V.r.m.s.	1000 V.r.m.s.	1000 V.r.m.s.	1000 V.r.m.s.
300 V.r.m.s.	300 V.r.m.s.	300 V.r.m.s.	300 V.r.m.s.	300 V.r.m.s.	300 V.r.m.s.
≥ 5000 MΩ	≥ 5000 MΩ	≥ 5000 MΩ	≥ 5000 MΩ	≥ 5000 MΩ	≥ 5000 MΩ
≤ 10 mΩ *	≤ 10 mΩ *	≤ 25 mΩ	≤ 7.3 mΩ	≤ 7.3 mΩ	≤ 7.3 mΩ
5N Max. / 0.3N min.	5N Max. / 0.3N min.	5N Max. / 0.3N min.	5N Max. / 0.3N min.	5N Max. / 0.3N min.	5N Max. / 0.3N min.
200 min.	200 min.	200 min.	200 min.	500	500
1 mm	1 mm	0.76 mm	1 mm	1 mm	1 mm (signal contact)
yes	no	no	no	no	yes (coax and power)
AWG 20 Max.	AWG 26 to AWG 30		AWG 20 Max	AWG 20	AWG 20 (signal contact) other see page 48
1.52 mm	Flat cable		2.1 mm	2.1 mm	2.1 mm
9, 15, 25, 37, 50 Male and Female	9, 15, 25, 37 Male and Female	Solder : 15, 26, 44, 62 Press-fit : 62, 78	9, 15, 25, 37, 50 Male and Female	9, 15, 25, 37, 50 Male and Female	9, 15, 25, 37, 50 Male and Female

DELTA D

Right angle solder



UL Recognized File E 118235 (R)

The DELTA D series has been developed to meet the current requirements of industry (industrial electronics, computers, medical equipment, private exchanges...).

Its development integrates today's demand for ever-increasing rationalization (automation, robots for automatic placement...).

It has been designed and industrialized with the help of the most recent technologies: CAD, 100 % automatic assembly, in-process quality control, etc...

The DELTA D series has angled terminations of different lengths, stamped contacts and is available in the most popular arrangements (9, 15, 25, 37 male/female contacts).

It meets european standards and US Std (HE 5, DIN 41652 and MIL-DTL 24308).

Various options can be selected: threaded inserts, female jack screws, harpoons, grounding device...



Ordering information

Series	D	25	P	13 A	4	GV	00LF																														
Number of contacts	09, 15, 25, 37																																				
Contacts	P : Pin S : Socket																																				
Termination	<table border="1"> <thead> <tr> <th>Code</th> <th>Type</th> <th>Foot print/Pitch</th> <th>Length of termination</th> <th>PCB thickness</th> </tr> </thead> <tbody> <tr> <td>☺ 13 A</td> <td>Right angled – Europe standard</td> <td>10.4 / 2.54 mm</td> <td>2.90</td> <td>1.6</td> </tr> <tr> <td>13 B</td> <td>Right angled – Europe standard</td> <td>10.4 / 2.54 mm</td> <td>3.70</td> <td>2.4 and 1.6</td> </tr> <tr> <td>23 A</td> <td>Right angled – Europe standard</td> <td>10.4 / 2.84 mm</td> <td>2.90</td> <td>1.6</td> </tr> <tr> <td>23 B</td> <td>Right angled – Europe standard</td> <td>10.4 / 2.84 mm</td> <td>3.70</td> <td>2.4 and 1.6</td> </tr> <tr> <td>☺ 33 E</td> <td>Right angled – US standard</td> <td>8.08 / 2.84 mm</td> <td>3.18</td> <td>1.6</td> </tr> </tbody> </table>							Code	Type	Foot print/Pitch	Length of termination	PCB thickness	☺ 13 A	Right angled – Europe standard	10.4 / 2.54 mm	2.90	1.6	13 B	Right angled – Europe standard	10.4 / 2.54 mm	3.70	2.4 and 1.6	23 A	Right angled – Europe standard	10.4 / 2.84 mm	2.90	1.6	23 B	Right angled – Europe standard	10.4 / 2.84 mm	3.70	2.4 and 1.6	☺ 33 E	Right angled – US standard	8.08 / 2.84 mm	3.18	1.6
Code	Type	Foot print/Pitch	Length of termination	PCB thickness																																	
☺ 13 A	Right angled – Europe standard	10.4 / 2.54 mm	2.90	1.6																																	
13 B	Right angled – Europe standard	10.4 / 2.54 mm	3.70	2.4 and 1.6																																	
23 A	Right angled – Europe standard	10.4 / 2.84 mm	2.90	1.6																																	
23 B	Right angled – Europe standard	10.4 / 2.84 mm	3.70	2.4 and 1.6																																	
☺ 33 E	Right angled – US standard	8.08 / 2.84 mm	3.18	1.6																																	
Plating	4 : Standard class (≥ 200 mating / unmating) 6 : High performance class (≥ 500 mating / unmating) - LNZ 4404																																				
Mounting options (see cover page 61)	<table border="1"> <thead> <tr> <th>Options</th> <th></th> </tr> </thead> <tbody> <tr> <td>PA</td> <td>Standard hole</td> </tr> <tr> <td>PL</td> <td>Threaded insert M3</td> </tr> <tr> <td>PX</td> <td>Threaded insert UNC 4-40</td> </tr> <tr> <td>PV</td> <td>Female screw UNC 4-40</td> </tr> <tr> <td>GI</td> <td>Harpoons + Female screw M3 + elec. continuity</td> </tr> <tr> <td>GL</td> <td>Harpoons + insert M3 + elec. continuity</td> </tr> <tr> <td>☺ GX</td> <td>Harpoons + insert UNC 4-40 + elec. continuity</td> </tr> <tr> <td>☺ GV</td> <td>Harpoons + female screw UNC 4-40 + elec. continuity</td> </tr> <tr> <td>UA</td> <td>Elec. continuity</td> </tr> <tr> <td>UL</td> <td>Insert M3 + elec. continuity</td> </tr> <tr> <td>UX</td> <td>Insert UNC 4-40 + elec. continuity</td> </tr> <tr> <td>UV</td> <td>Female screw UNC 4-40 + elec. continuity</td> </tr> </tbody> </table>							Options		PA	Standard hole	PL	Threaded insert M3	PX	Threaded insert UNC 4-40	PV	Female screw UNC 4-40	GI	Harpoons + Female screw M3 + elec. continuity	GL	Harpoons + insert M3 + elec. continuity	☺ GX	Harpoons + insert UNC 4-40 + elec. continuity	☺ GV	Harpoons + female screw UNC 4-40 + elec. continuity	UA	Elec. continuity	UL	Insert M3 + elec. continuity	UX	Insert UNC 4-40 + elec. continuity	UV	Female screw UNC 4-40 + elec. continuity				
Options																																					
PA	Standard hole																																				
PL	Threaded insert M3																																				
PX	Threaded insert UNC 4-40																																				
PV	Female screw UNC 4-40																																				
GI	Harpoons + Female screw M3 + elec. continuity																																				
GL	Harpoons + insert M3 + elec. continuity																																				
☺ GX	Harpoons + insert UNC 4-40 + elec. continuity																																				
☺ GV	Harpoons + female screw UNC 4-40 + elec. continuity																																				
UA	Elec. continuity																																				
UL	Insert M3 + elec. continuity																																				
UX	Insert UNC 4-40 + elec. continuity																																				
UV	Female screw UNC 4-40 + elec. continuity																																				
Options	00 : Standard series, non RoHS compatible ☺ 00LF : Standard series, RoHS compatible																																				

DELTA D

Right angle solder

Specific dimensions

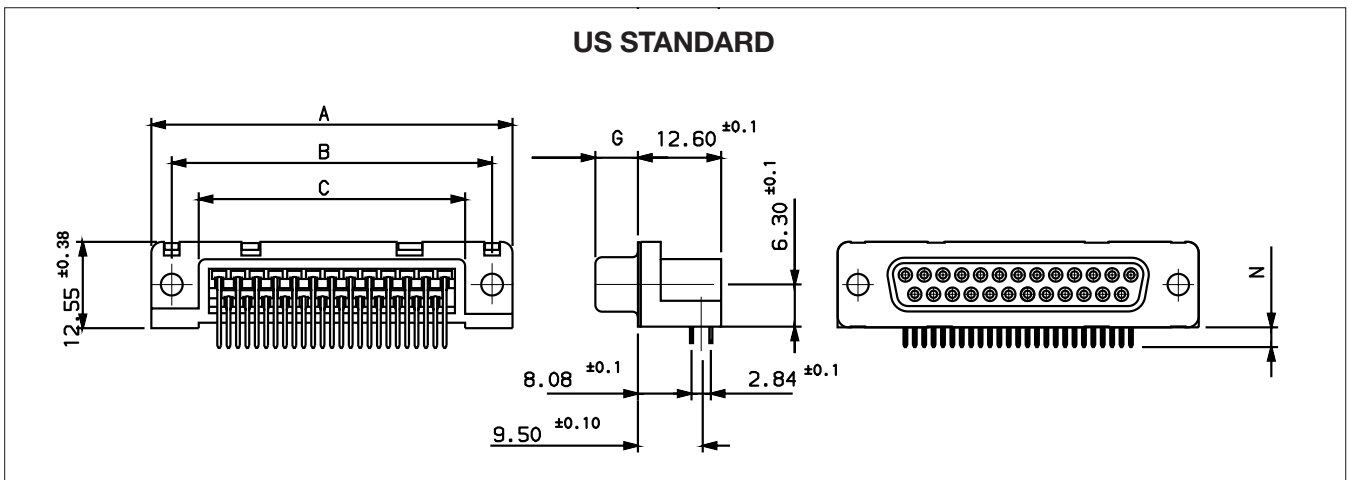
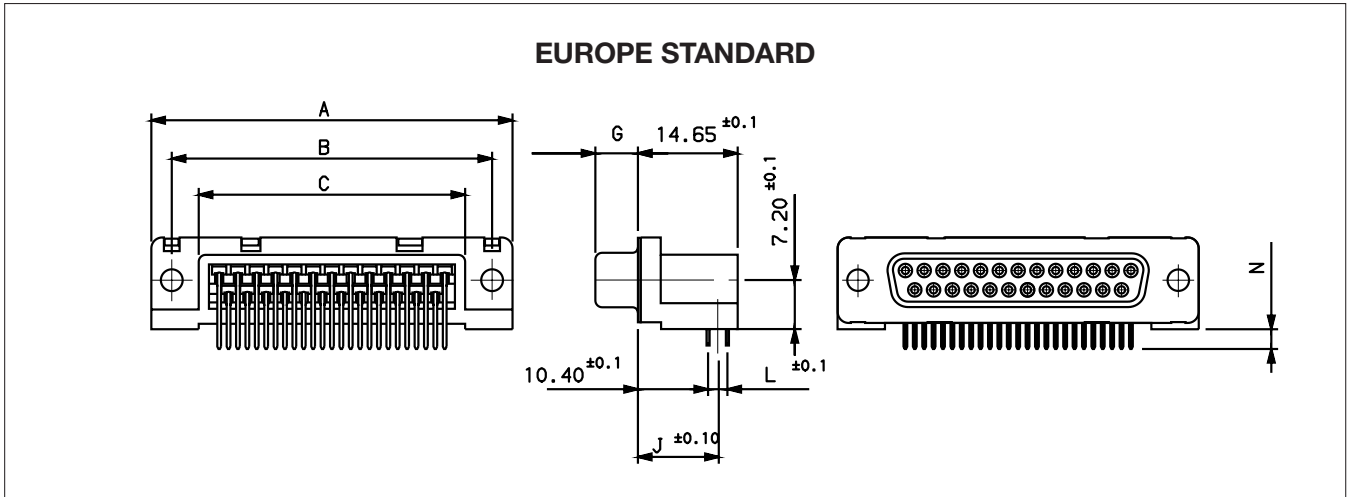







		A ± 0.38	B ± 0.12	C ± 0.10	G $^{+0.25}_{-0}$	J ± 0.10		L ± 0.1		N ± 0.30		
						Termination		Termination		Terminal Length		
						13.	23.	13.	23.	13 A 23 A	13 B 23 B	33 E
9	P	30.81	24.99	16.96	5.90 $^{+0.15}_{-0}$	11.67	11.82	2.54	2.84	2.90	3.70	3.18
	S	30.81	24.99	16.96	6.05	11.67	11.82	2.54	2.84	2.90	3.70	3.18
15	P	39.14	33.32	25.18	5.90 $^{+0.15}_{-0}$	11.67	11.82	2.54	2.84	2.90	3.70	3.18
	S	39.14	33.32	25.18	6.05	11.67	11.82	2.54	2.84	2.90	3.70	3.18
25	P	53.03	47.04	39.12	5.70	11.67	11.82	2.54	2.84	2.90	3.70	3.18
	S	53.03	47.04	39.12	6.05	11.67	11.82	2.54	2.84	2.90	3.70	3.18
37	P	69.32	63.50	55.68	5.70	11.67	11.82	2.54	2.84	2.90	3.70	3.18
	S	69.32	63.50	55.68	6.05	11.67	11.82	2.54	2.84	2.90	3.70	3.18

DELTA D Straight solder

 UL Recognized File E 118235 (R)



Ordering information

Series	D	25	P	24 A	4	GV	00LF																									
Number of contacts	09, 15, 25, 37, 50																															
Contacts	P : Pin S : Socket																															
Terminations	<table border="1"> <thead> <tr> <th>Code</th> <th>Type</th> <th>Foot print/Pitch</th> <th>Length of termination</th> <th>PCB thickness</th> </tr> </thead> <tbody> <tr> <td>14 A</td> <td>Straight version (low profile)</td> <td>5.6 / 2.84 mm</td> <td>2.90</td> <td>1.6</td> </tr> <tr> <td> 24 A</td> <td>Straight version</td> <td>6 / 2.84 mm</td> <td>2.90</td> <td>1.6</td> </tr> <tr> <td>24 B</td> <td>Straight version</td> <td>6 / 2.84 mm</td> <td>3.70</td> <td>2.4</td> </tr> <tr> <td>34 A</td> <td>Straight version</td> <td>6.9 / 2.84 mm</td> <td>2.90</td> <td>1.6</td> </tr> </tbody> </table>							Code	Type	Foot print/Pitch	Length of termination	PCB thickness	14 A	Straight version (low profile)	5.6 / 2.84 mm	2.90	1.6	 24 A	Straight version	6 / 2.84 mm	2.90	1.6	24 B	Straight version	6 / 2.84 mm	3.70	2.4	34 A	Straight version	6.9 / 2.84 mm	2.90	1.6
Code	Type	Foot print/Pitch	Length of termination	PCB thickness																												
14 A	Straight version (low profile)	5.6 / 2.84 mm	2.90	1.6																												
 24 A	Straight version	6 / 2.84 mm	2.90	1.6																												
24 B	Straight version	6 / 2.84 mm	3.70	2.4																												
34 A	Straight version	6.9 / 2.84 mm	2.90	1.6																												
Plating	4 : Standard class (≥ 200 mating / unmating) 6 : High performance class (≥ 500 mating / unmating) - LNZ 4404 -																															
Mounting options (see cover page 61)	<table border="1"> <thead> <tr> <th>Options</th> <th></th> </tr> </thead> <tbody> <tr> <td>PA</td> <td>Standard hole</td> </tr> <tr> <td>PL</td> <td>Threaded insert M3</td> </tr> <tr> <td>PX</td> <td>Threaded insert UNC 4-40</td> </tr> <tr> <td>PV</td> <td>Female screw UNC 4-40</td> </tr> <tr> <td>GL</td> <td>Harpoons + insert M3 + elec. continuity</td> </tr> <tr> <td>GX</td> <td>Harpoons + insert UNC 4-40 + elec. continuity</td> </tr> <tr> <td> GV</td> <td>Harpoons + Female screw UNC 4-40 + elec. continuity</td> </tr> </tbody> </table>							Options		PA	Standard hole	PL	Threaded insert M3	PX	Threaded insert UNC 4-40	PV	Female screw UNC 4-40	GL	Harpoons + insert M3 + elec. continuity	GX	Harpoons + insert UNC 4-40 + elec. continuity	 GV	Harpoons + Female screw UNC 4-40 + elec. continuity									
Options																																
PA	Standard hole																															
PL	Threaded insert M3																															
PX	Threaded insert UNC 4-40																															
PV	Female screw UNC 4-40																															
GL	Harpoons + insert M3 + elec. continuity																															
GX	Harpoons + insert UNC 4-40 + elec. continuity																															
 GV	Harpoons + Female screw UNC 4-40 + elec. continuity																															
Other options	00 : Standard series, non RoHS compatible  00LF : Standard series, RoHS compatible																															

DELTA D Straight solder

Specific dimensions

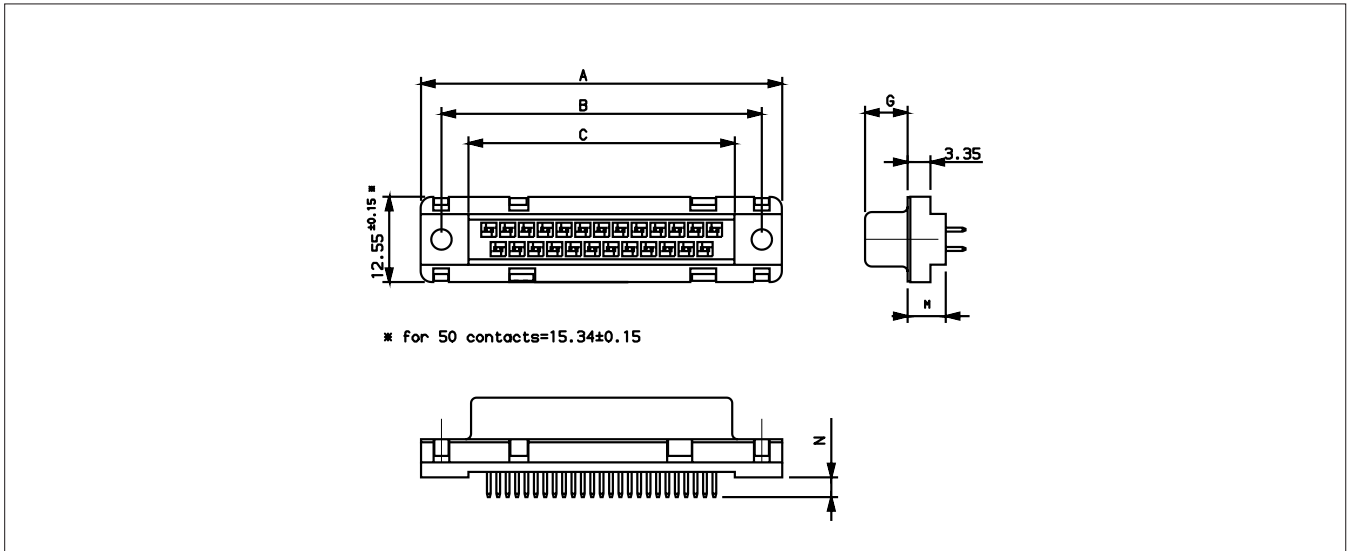

		A±0.38	B±0.12	C±0.10	G ^{+0.25} ₀	M±0.10			N±0.30	
						Termination			Terminal Length	
						14.	24.	34.	14 A 24 A 34 A	24 B
9	P	30.81	24.99	16.96	5.90 ^{+0.15} ₋₀	5.60	6.00	6.90	2.90	3.70
	S	30.81	24.99	16.96	6.05	5.60	6.00	6.90	2.90	3.70
15	P	39.14	33.32	25.18	5.90 ^{+0.15} ₋₀	5.60	6.00	6.90	2.90	3.70
	S	39.14	33.32	25.18	6.05	5.60	6.00	6.90	2.90	3.70
25	P	53.03	47.04	39.12	5.70	5.60	6.00	6.90	2.90	3.70
	S	53.03	47.04	39.12	6.05	5.60	6.00	6.90	2.90	3.70
37	P	69.32	63.50	55.68	5.70	5.60	6.00	6.90	2.90	3.70
	S	69.32	63.50	55.68	6.05	5.60	6.00	6.90	2.90	3.70
50	P	67.10	61.11	54.11	5.70	5.60	6.00	6.90	2.90	3.70
	S	67.10	61.11	54.11	6.05	5.60	6.00	6.90	2.90	3.70

DELTA D

Straight press-fit

Press-fit termination



In case of SMT (Surface Mount Technology) manufacturing process this new press-fit Delta D allows to save cost of an additional wave soldering. The “eye of the needle” termination combined with a special flat rock design (easy application by pressure on insulator) make this product line very attractive.



Ordering information

Series	D	25	P	91 C	4	PA	00LF																
Number of contacts	09, 15, 25, 37, 50																						
Contacts	P : Pin S : Socket																						
Termination type	😊 91 C : Press-fit for all 3 PCB thickness : (1.6 mm ; 2.4 mm ; 3.2 mm and more) - Europe standard 90 C : Press-fit for all 3 PCB thickness : (1.6 mm ; 2.4 mm ; 3.2 mm and more) - Low profile																						
Plating	4 : Standard class (≥ 200 mating / unmating) 6 : High performance class (≥ 500 mating / unmating)																						
Mounting options (see cover page 61)	<table border="1"> <thead> <tr> <th>Options</th> <th></th> </tr> </thead> <tbody> <tr> <td>PA</td> <td>Standard hole</td> </tr> <tr> <td>PL</td> <td>Threaded insert M3</td> </tr> <tr> <td>😊 PX</td> <td>Threaded insert UNC 4-40</td> </tr> <tr> <td>😊 PV</td> <td>Female screw UNC 4-40</td> </tr> <tr> <td>GL</td> <td>Harpoons + insert M3 + elec. continuity</td> </tr> <tr> <td>GX</td> <td>Harpoons + insert UNC 4-40 + elec. continuity</td> </tr> <tr> <td>GV</td> <td>Harpoons + Female screw UNC 4-40 + elec. continuity</td> </tr> </tbody> </table>							Options		PA	Standard hole	PL	Threaded insert M3	😊 PX	Threaded insert UNC 4-40	😊 PV	Female screw UNC 4-40	GL	Harpoons + insert M3 + elec. continuity	GX	Harpoons + insert UNC 4-40 + elec. continuity	GV	Harpoons + Female screw UNC 4-40 + elec. continuity
Options																							
PA	Standard hole																						
PL	Threaded insert M3																						
😊 PX	Threaded insert UNC 4-40																						
😊 PV	Female screw UNC 4-40																						
GL	Harpoons + insert M3 + elec. continuity																						
GX	Harpoons + insert UNC 4-40 + elec. continuity																						
GV	Harpoons + Female screw UNC 4-40 + elec. continuity																						
Other options	😊 00 : Standard series, non RoHS compatible 😊 00LF : Standard series, RoHS compatible																						

DELTA D

Straight press-fit

Specific dimensions

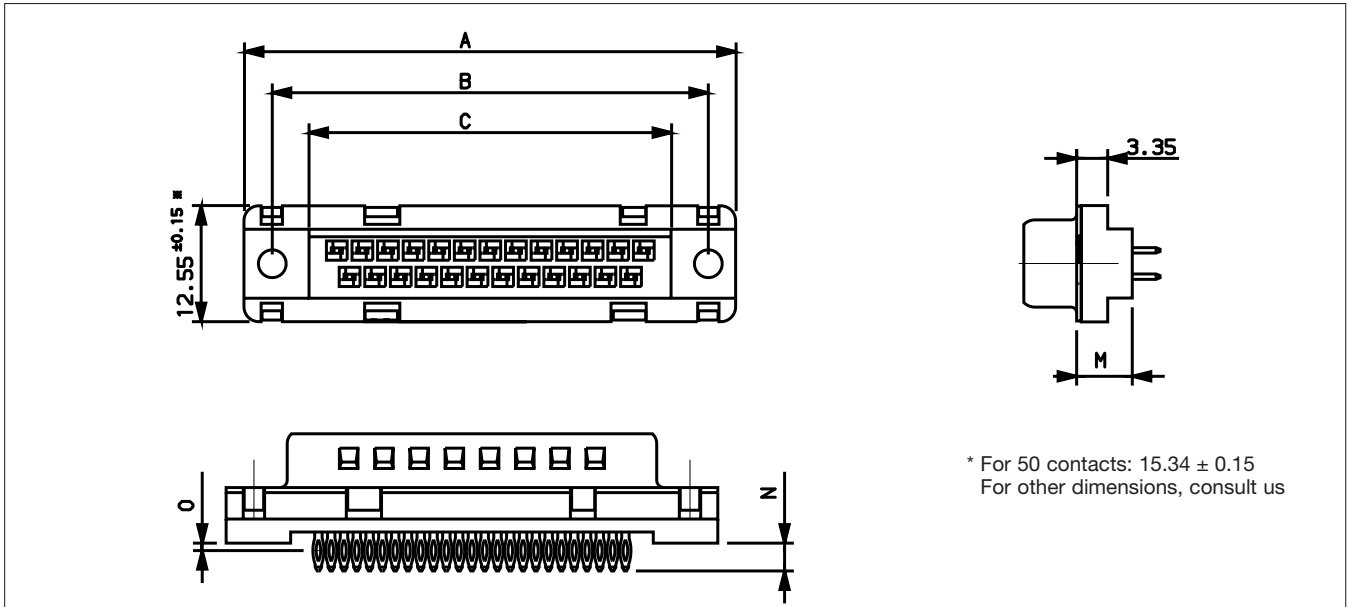

Size	A±0.38	B± 0.12	C± 0.10
09	30.81	24.99	16.96
15	39.14	33.32	25.18
25	53.03	47.04	39.12
37	69.32	63.50	55.68
50	66.93	61.11	53.11

Termination type	M±0.1	N±0.3	O±0.2
90 C	5.60	3.40	1.20
91 C	6.00	3.00	0.80

Press-fit features

Application by pressure on insulator • D-Sub insertion kit : 8646 3064 01
Eye of the needle design.

• Metallized hole dimensions

		Press-fit contacts	Press-fit harpoons	
P.C.B. hole definition (note 1 and 2)		Drill diameter	Ø 1.15 ref (note 3)	Ø 3.22 ref (note 3)
		Drilled hole	Ø 1.18 - 1.2	Ø 3.19 - 3.25
		Copper plating	25 µm min (recommended 50 µ max)	25 µm min (recommended 50 µ max)
	non RoHS	Tin-lead plating	15 µm max (recommended 5 µ min)	15 µm max (recommended 5 µ min)
		Finish hole (after reflow)	Ø 0.94 - 1.09	Ø 3.02 - 3.20
	RoHS	Tin plating	0.8 to 1.2 µm	0.8 to 1.2 µm
Finish hole (after reflow)		Ø 1.00 - 1.09	Ø 3.08 - 3.20	

Note 1 : These dimensions must be respected to ensure press-fit pin performance

Note 2 : According to IEC-352-S specification

Note 3 : Vital requirement for press-fit pin performance

• Press-fit performance

	Press-fit contacts	Press-fit harpoons
Insertion force	≤ 100 N	≤ 120 N
Extraction force	≥ 30 N	≥ 30 N

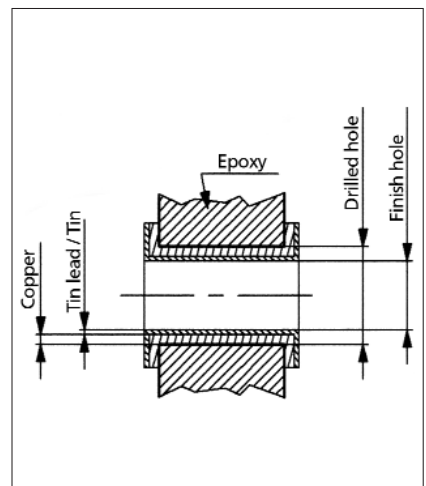











DELTA D

Right angle press-fit

 UL Recognized File E 118235 (R)



Ordering information

Series	D	25	P	82 C	4	PA	00LF																
Number of contacts	09, 15, 25, 37, 50 (only for Eurostyle version)																						
Contacts	P : Pin S : Socket																						
Termination type	<table border="1"> <thead> <tr> <th>Code</th> <th>Type</th> <th colspan="2">Foot print / Pitch</th> </tr> </thead> <tbody> <tr> <td> 82 C</td> <td>Eurostyle</td> <td>9.4 / 2.54 10.3 / 2.54</td> <td>9 to 37 way 50 way</td> </tr> <tr> <td>80 C</td> <td>US standard</td> <td>8.08 / 2.84</td> <td>9 to 37 way</td> </tr> <tr> <td>81 C</td> <td>Europe standard*</td> <td>10.4 / 2.54</td> <td>9 to 37 way</td> </tr> </tbody> </table>							Code	Type	Foot print / Pitch		 82 C	Eurostyle	9.4 / 2.54 10.3 / 2.54	9 to 37 way 50 way	80 C	US standard	8.08 / 2.84	9 to 37 way	81 C	Europe standard*	10.4 / 2.54	9 to 37 way
Code	Type	Foot print / Pitch																					
 82 C	Eurostyle	9.4 / 2.54 10.3 / 2.54	9 to 37 way 50 way																				
80 C	US standard	8.08 / 2.84	9 to 37 way																				
81 C	Europe standard*	10.4 / 2.54	9 to 37 way																				
Plating	4 : Standard class (≥ 200 mating / unmating) 6 : High performance class (≥ 500 mating / unmating)																						
Mounting options (see cover page 61)	<table border="1"> <thead> <tr> <th>Options</th> <th></th> </tr> </thead> <tbody> <tr> <td>PA</td> <td>Standard hole</td> </tr> <tr> <td>PL</td> <td>Threaded insert M3</td> </tr> <tr> <td>PX</td> <td>Threaded insert UNC 4-40</td> </tr> <tr> <td>PV</td> <td>Female screw UNC 4-40</td> </tr> <tr> <td>GL</td> <td>Harpoons + insert M3</td> </tr> <tr> <td> GX</td> <td>Harpoons + insert UNC 4-40</td> </tr> <tr> <td> GV</td> <td>Harpoons + Female screw UNC 4-40</td> </tr> </tbody> </table>							Options		PA	Standard hole	PL	Threaded insert M3	PX	Threaded insert UNC 4-40	PV	Female screw UNC 4-40	GL	Harpoons + insert M3	 GX	Harpoons + insert UNC 4-40	 GV	Harpoons + Female screw UNC 4-40
Options																							
PA	Standard hole																						
PL	Threaded insert M3																						
PX	Threaded insert UNC 4-40																						
PV	Female screw UNC 4-40																						
GL	Harpoons + insert M3																						
 GX	Harpoons + insert UNC 4-40																						
 GV	Harpoons + Female screw UNC 4-40																						
Other options	00 : Standard, non RoHS compatible  00LF : Standard, RoHS compatible																						

DELTA D

Right angle press-fit

Specific dimensions

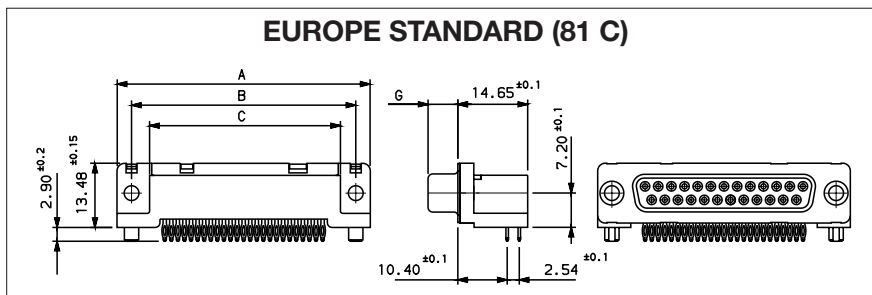
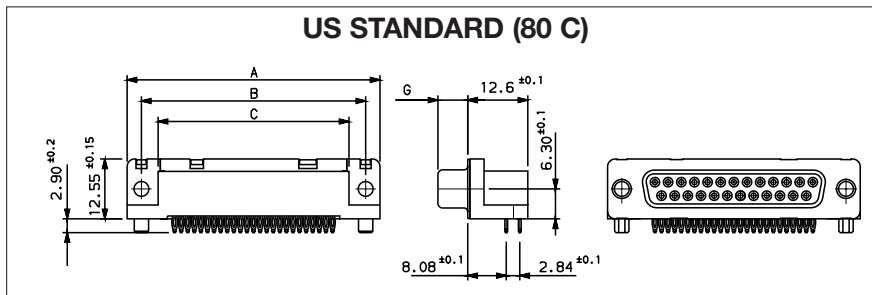
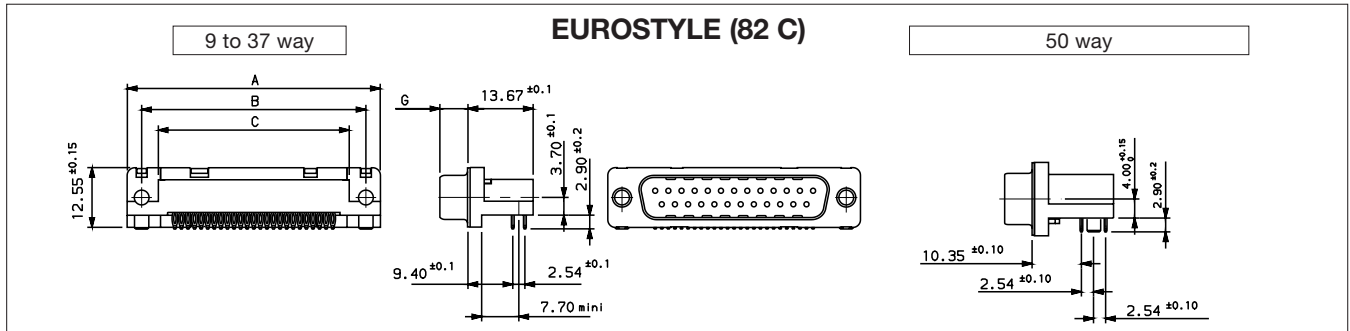

	A ^{±0.38}	B ^{±0.12}	C ^{±0.10}	G ^{+0.25 -0}	
9	P	30.81	24.99	18.00	5.90 ^{+0.15}
	S	30.81	24.99	18.00	6.05
15	P	39.14	33.32	26.32	5.90 ^{+0.15}
	S	39.14	33.32	26.32	6.05
25	P	53.03	47.04	40.04	5.70
	S	53.03	47.04	40.04	6.05
37	P	69.32	63.50	55.50	5.70
	S	69.32	63.50	55.50	6.05
50*	P	67.10	61.11	54.10	5.70
	S	67.10	61.11	54.10	6.05

* Only for Eurostyle version.

Press-fit features

Application by pressure on insulator • D-Sub insertion kit : 8646 3064 01
Eye of the needle design.

• Metallized hole dimensions

P.C.B. hole definition (note 1 and 2)		Press-fit contacts		Press-fit harpoons	
			Drill diameter	Ø 1.15 ref (note 3)	Ø 3.22 ref (note 3)
non RoHS		Drilled hole	Ø 1.18 - 1.2	Ø 3.19 - 3.25	
		Copper plating	25 µm min (recommended 50 µ max)	25 µm min (recommended 50 µ max)	
		Tin-lead plating	15 µm max (recommended 5 µ min)	15 µm max (recommended 5 µ min)	
		Finish hole (after reflow)	Ø 0.94 - 1.09	Ø 3.02 - 3.20	
RoHS		Tin plating	0.8 to 1.2 µm	0.8 to 1.2 µm	
		Finish hole (after reflow)	Ø 1.00 - 1.09	Ø 3.08 - 3.20	

Note 1 : These dimensions must be respected to ensure press-fit pin performance

Note 2 : According to IEC-352-S specification

Note 3 : Vital requirement for press-fit pin performance

• Press-fit performance

	Press-fit contacts	Press-fit harpoons
Insertion force	≤ 100 N	≤ 120 N
Extraction force	≥ 30 N	≥ 30 N

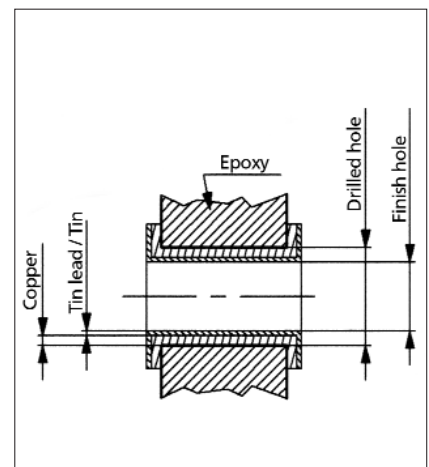

COMPACT D

High density solder



COMPACT D Series has been developed to answer the increasing need for higher density packaging.



Ordering information

Series	ICD	14	S	13 E	6	GX	00LF
Number of contacts 14, 15, 26, 44, 62							
Contacts S : Female							
Termination 😊 13E : Angled spills US Standard, 3.18 mm 😊 13A : Angled spills US Standard, 2,90 mm 😊 13B : Angled spills US Standard, 3.70 mm							
Plating 4 : Standard class (≥ 200 mating / unmating) 6 : High performance class (≥ 500 mating / unmating)							
Mounting options (see cover page 61) PA : Standard holes PL : Threaded insert (M3) PX : Threaded insert (UNC 4-40) PV : Female screw (UNC 4-40) 😊 GL : Harpoons + insert M3 + elec. continuity 😊 GX : Harpoons + insert UNC 4-40 + elec. continuity 😊 GV : Harpoons + female (UNC 4-40) + elec. continuity UL : Insert M3 + elec. continuity UX : Insert UNC 4-40 + elec. continuity UV : Female screw UNC 4-40 + elec. continuity							
Options 00 : Standard series, non RoHS compatible 😊 00LF : Standard series, RoHS compatible							

COMPACT D

High density solder

Specific dimensions

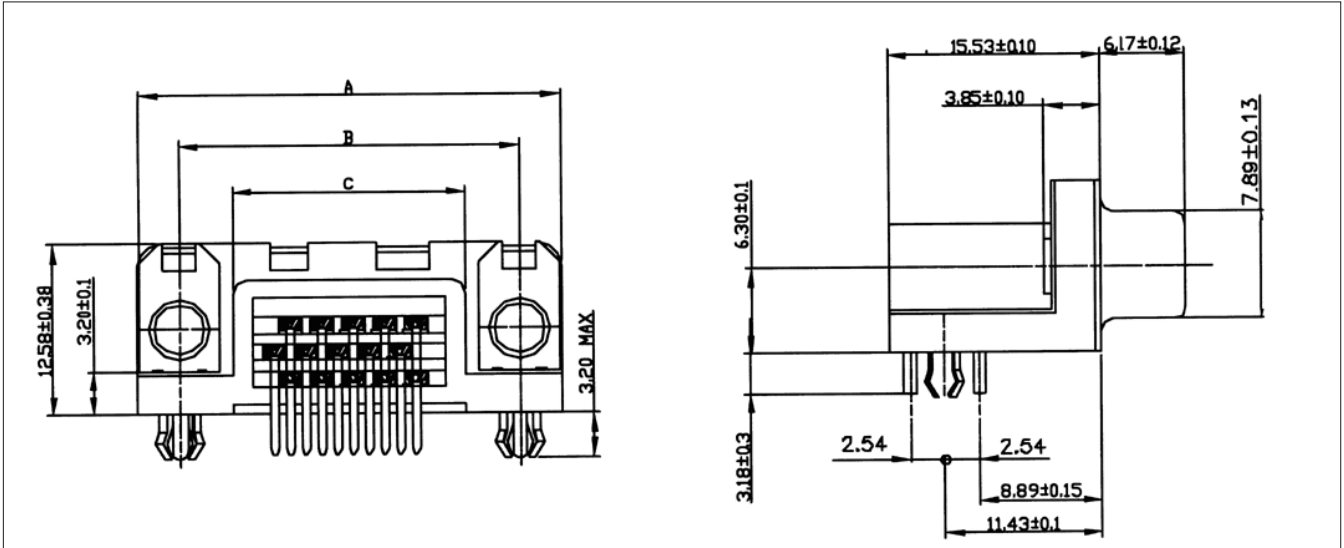

Size	Dimensions						
	A ± 0.38	B ± 0.12	C ± 0.10	D ± 0.25 0	E	F	G
14 / 15	30,81	24,99	16,96	16,21	7,68	8,19	2,285
26	39,14	33,32	25,18	24,54	7,02	8,01	2,285
44	53,03	47,04	39,12	38,25	7,01	8,02	2,285
62	69,32	63,50	55,68	54,71	7,03	8,21	2,41

PCB drilling dimensions

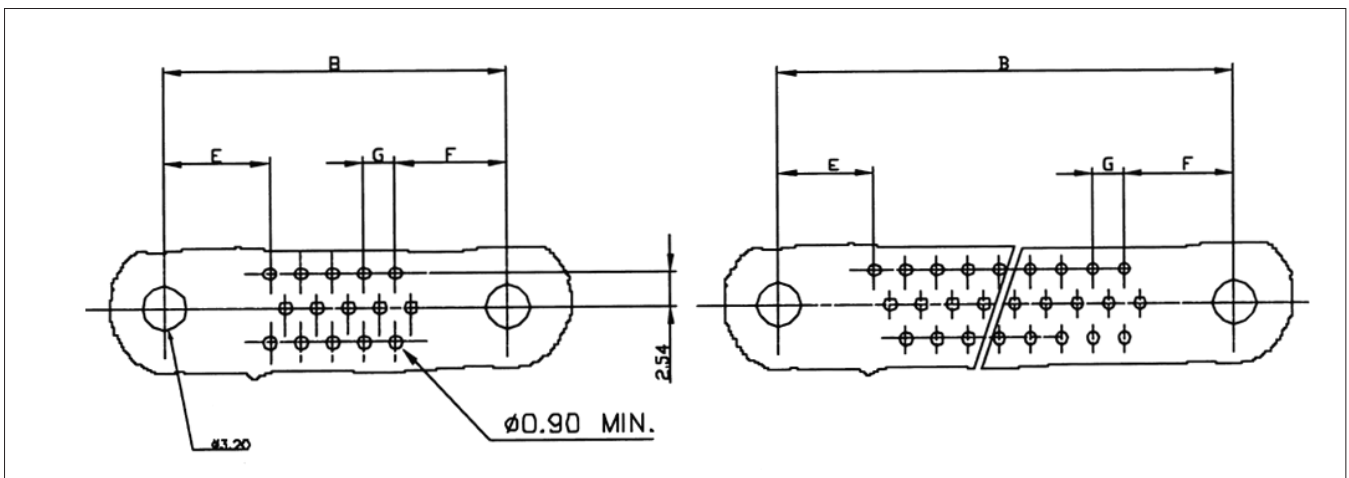

For 14 & 15 Position

For 26, 44 & 62 Position

PCB drilling details

COMPACT D

High density press-fit



Part number

Series	: 78 way right angle female press-fit	CD78S80C	6	GL	00LF
Plating	4 : Standard class (> 200 mating/unmating) 6 : High performance class (> 500 mating/unmating)				
Mounting options	GL : Harpoons + insert M3 + elec. continuity GX : Harpoons + insert UNC 4-40 + elec. continuity GV : Harpoons + female screw UNC 4-40 + elec. continuity				
Option	00 : non RoHS compatible 00LF : RoHS compatible EU directive 2002/95/EC				

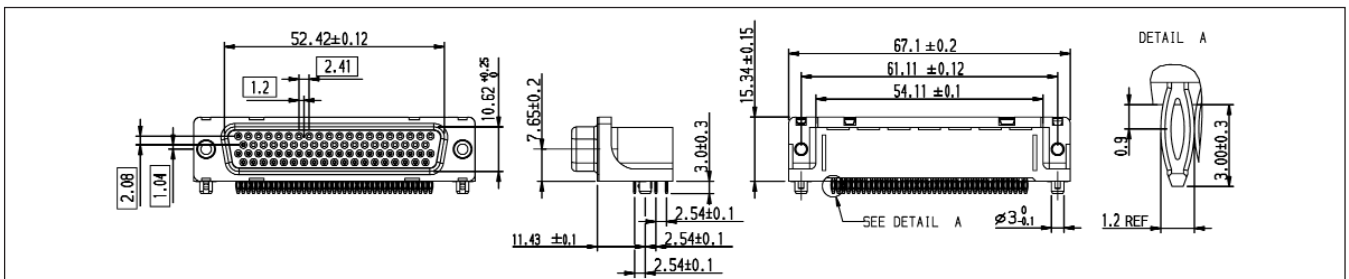

Series	: 78 way straight male press-fit	CD78P91C	6	GL	00LF
Plating	4 : Standard class (> 200 mating/unmating) 6 : High performance class (> 500 mating/unmating)				
Mounting options	GL : Harpoons + insert M3 + elec. continuity GX : Harpoons + insert UNC 4-40 + elec. continuity GV : Harpoons + female screw UNC 4-40 + elec. continuity				
Option	00 : non RoHS compatible 00LF : RoHS compatible EU directive 2002/95/EC				

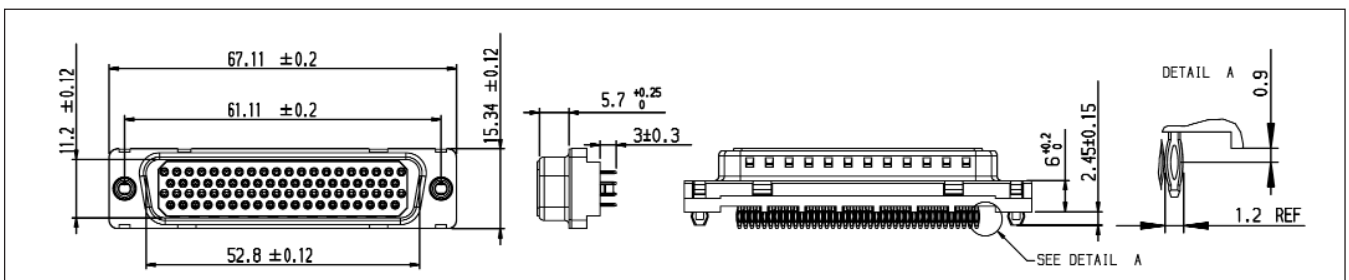

COMPACT D

High density press-fit

Part number

Series	: 62 way straight female press-fit	CD62S91C	6	GL	00LF
Plating					
4	: Standard class (> 200 mating/unmating)				
6	: High performance class (> 500 mating/unmating)				
Mounting options					
GL	: Harpoons + insert M3 + elec. continuity				
GX	: Harpoons + insert UNC 4-40 + elec. continuity				
GV	: Harpoons + female screw UNC 4-40 + elec. continuity				
Option					
00	: non RoHS compatible				
00LF	: RoHS compatible EU directive 2002/95/EC				

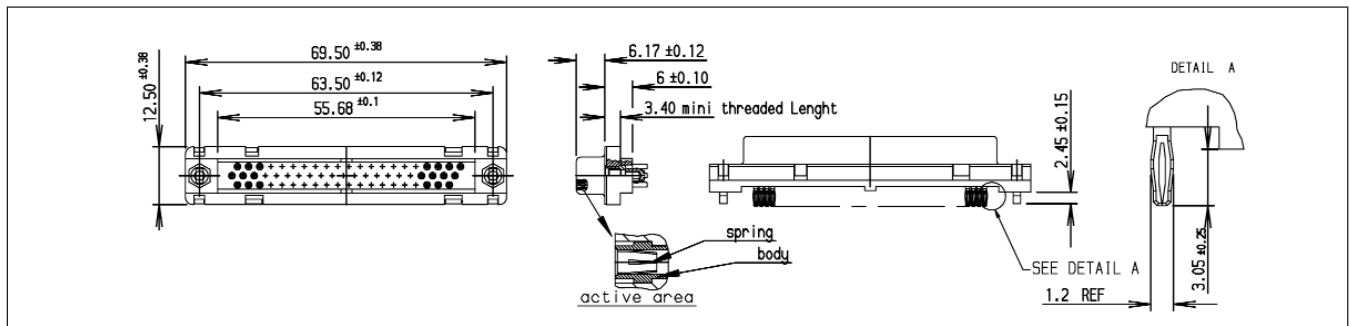

Press-fit features

Application by pressure on insulator
Eye of the needle design.

• Metallized hole dimensions

METALLIZED HOLE DIMENSION		HOLE PRESS-FIT CONTACT SnPb	HOLE PRESS-FIT CONTACT Sn	HOLE PRESS-FIT HARPOON SnPb	HOLE PRESS FIT HARPOON Sn	HOLE PRESS FIT CONTACT Copper OSP	HOLE PRESS-FIT HARPOON Copper OSP
P.C.B. HOLE DEFINITION (NOTE 1 and 2)	DRILL DIAMETER	∅ 1.15 REF (NOTE -3)	∅ 1.15 REF (NOTE -3)	∅3.22 REF (note-3)	∅3.22 REF (note 3)	∅1.15 REF (note 3)	∅3.22 REF (note-3)
	DRILLED HOLE	∅ 1.12 -1.18	∅ 1.12 -1.18	∅3.19-3.25	∅3.19-3.25	∅1.12-1.18	∅3.19-3.25
	COPPER PLATING	25µ mini-50µ maxi	25µ mini- 50µ maxi	25µ mini-50µ maxi	25µ mini-50µ maxi	25µ mini-50µ maxi	25µ mini-50µ maxi
	TIN LEAD PLATING	5µ mini - 15µ maxi		5µ mini-15µ maxi			
	PUR TIN PLATED		0.8 mini to 1.2µ maxi		0.8µ mini-1.2µ maxi		
	OSP PLATING (copper)					0.20µ mini-0.5µ maxi	0.20µ mini-0.5µ maxi
FINISH HOLE (note 4)	∅ 0.94-1.09	∅1.00-1.09	∅3.02-3.20	∅3.08-3.20	∅1.01-1.09	∅3.09-3.20	





• Press-fit performance



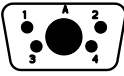
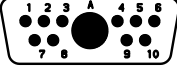

	PRESS-FIT CONTACTS	PRESS-FIT HARPONS
INSERTION FORCE	< 100N	< 120N
SnPb/Sn EXTRACTION FORCE	> 30N	> 30N
Copper EXTRACTION FORCE	> 20N	> 20N

Mixed power DW series

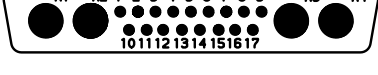
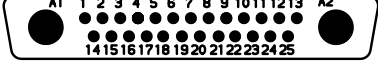
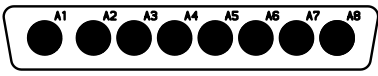
Layouts

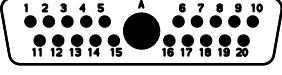
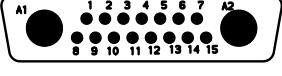
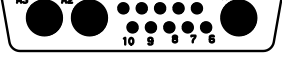
Male insulator front view

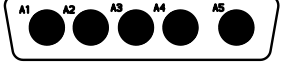
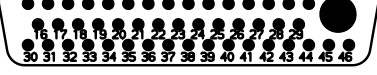
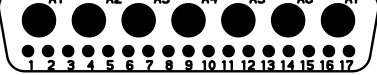
Shell size	Layout	
E	2V2	
	5W1	
A	11W1	
	7W2	
	3W3	
	3V3	
C	25W3	
	21WA4	
	27W2	
	8W8	

Shell size	Layout	
B	21W1	
	17W2	
	13W3	
	9W4	
D	5W5	
	47W1	
	24W7	
	36W4	

Mixed power DW series

Derating curve

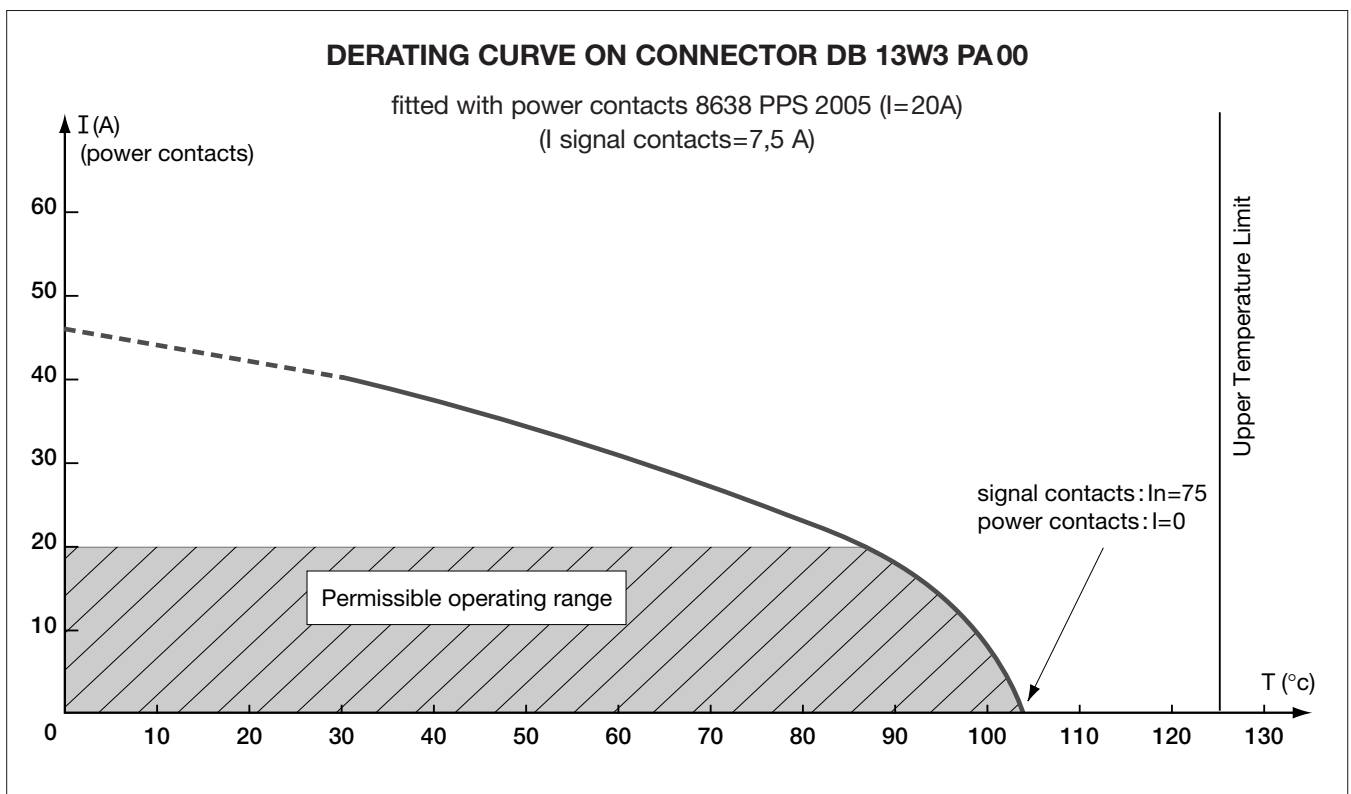
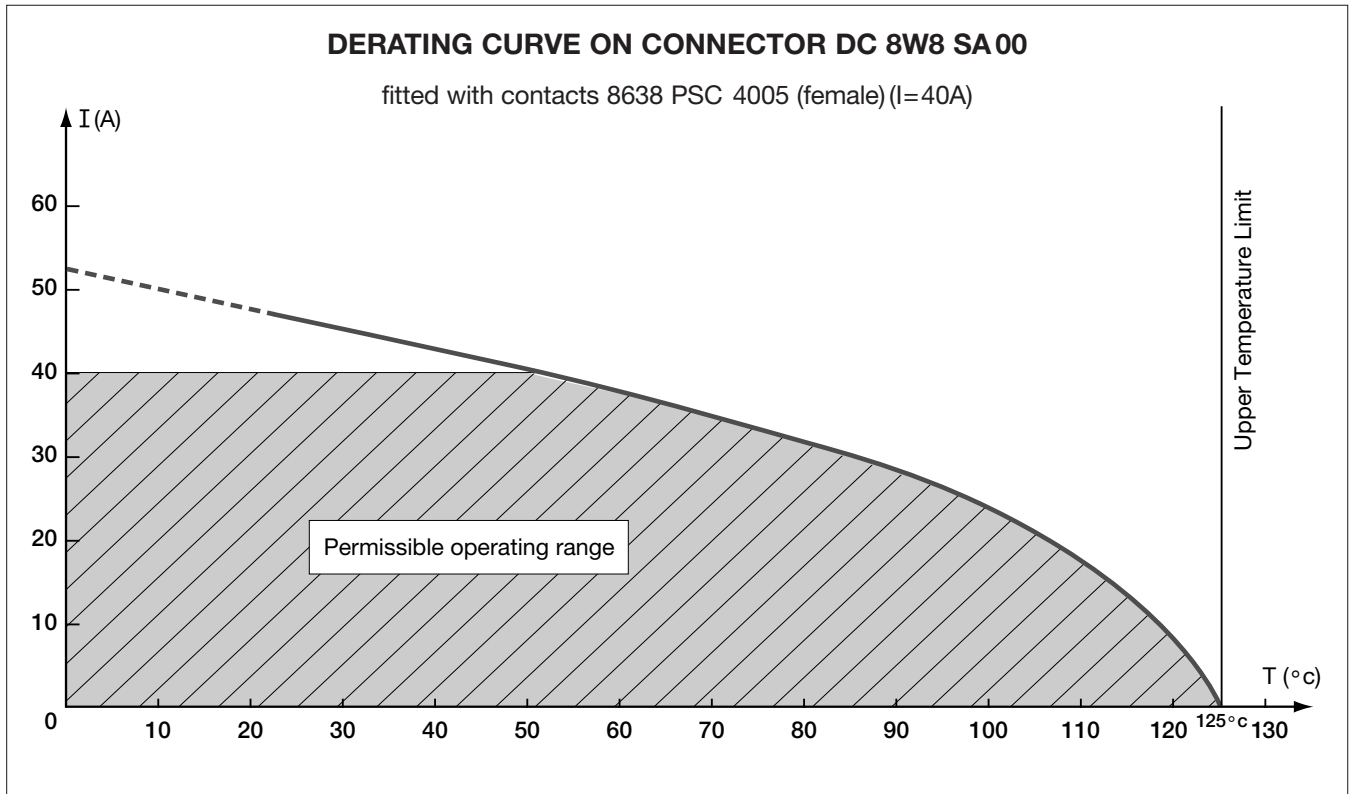

Mixed power DW series

Dimensions

PC board drilling

Solder termination

Version	Step	30 A	40 A
		Ø A	
3	2.84	Ø 2.40 \pm 0.10	Ø 3.10 \pm 0.10
7	2.84	Ø 2.40 \pm 0.10	
5	2.54	Ø 2.40 \pm 0.10	Ø 3.10 \pm 0.10

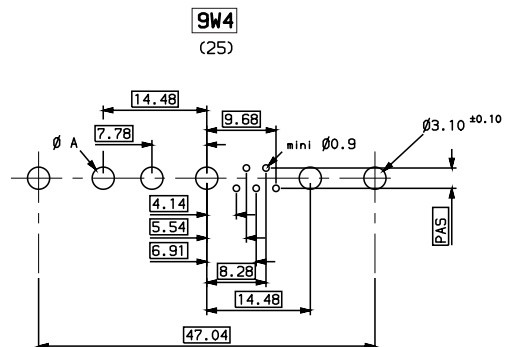
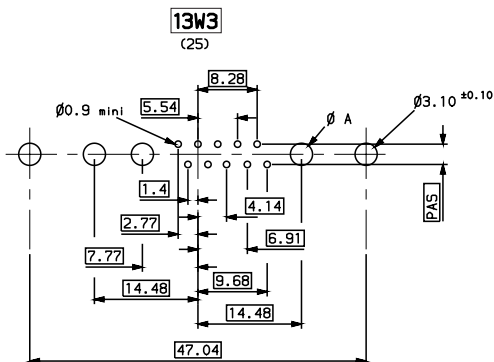
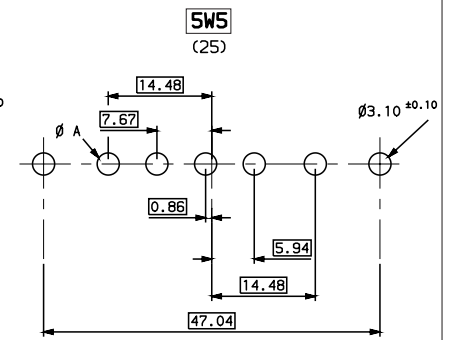
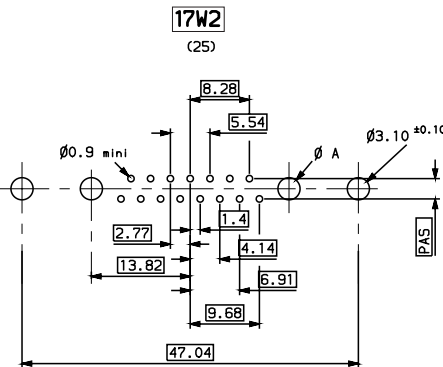
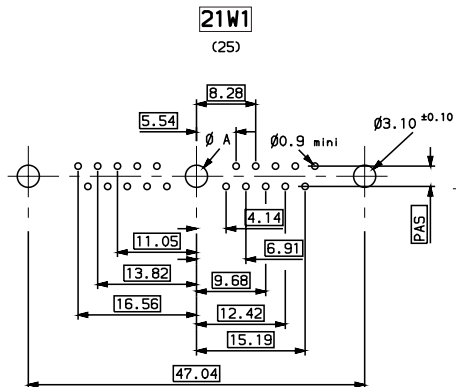
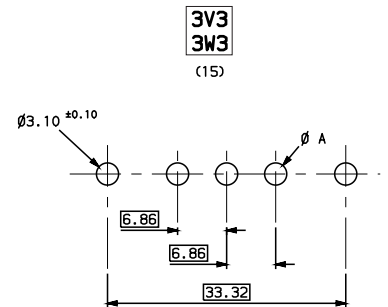
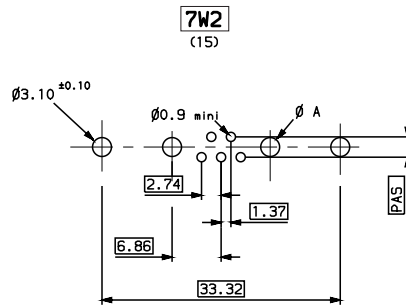
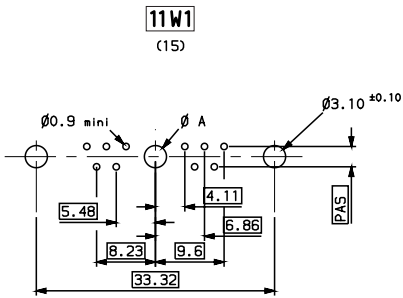
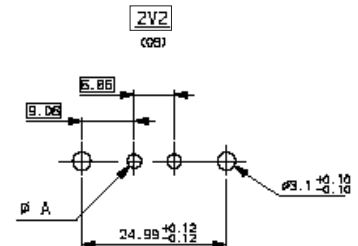
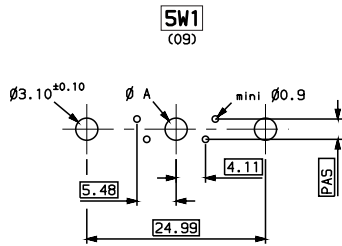

Mixed power DW series

Dimensions

PC board drilling

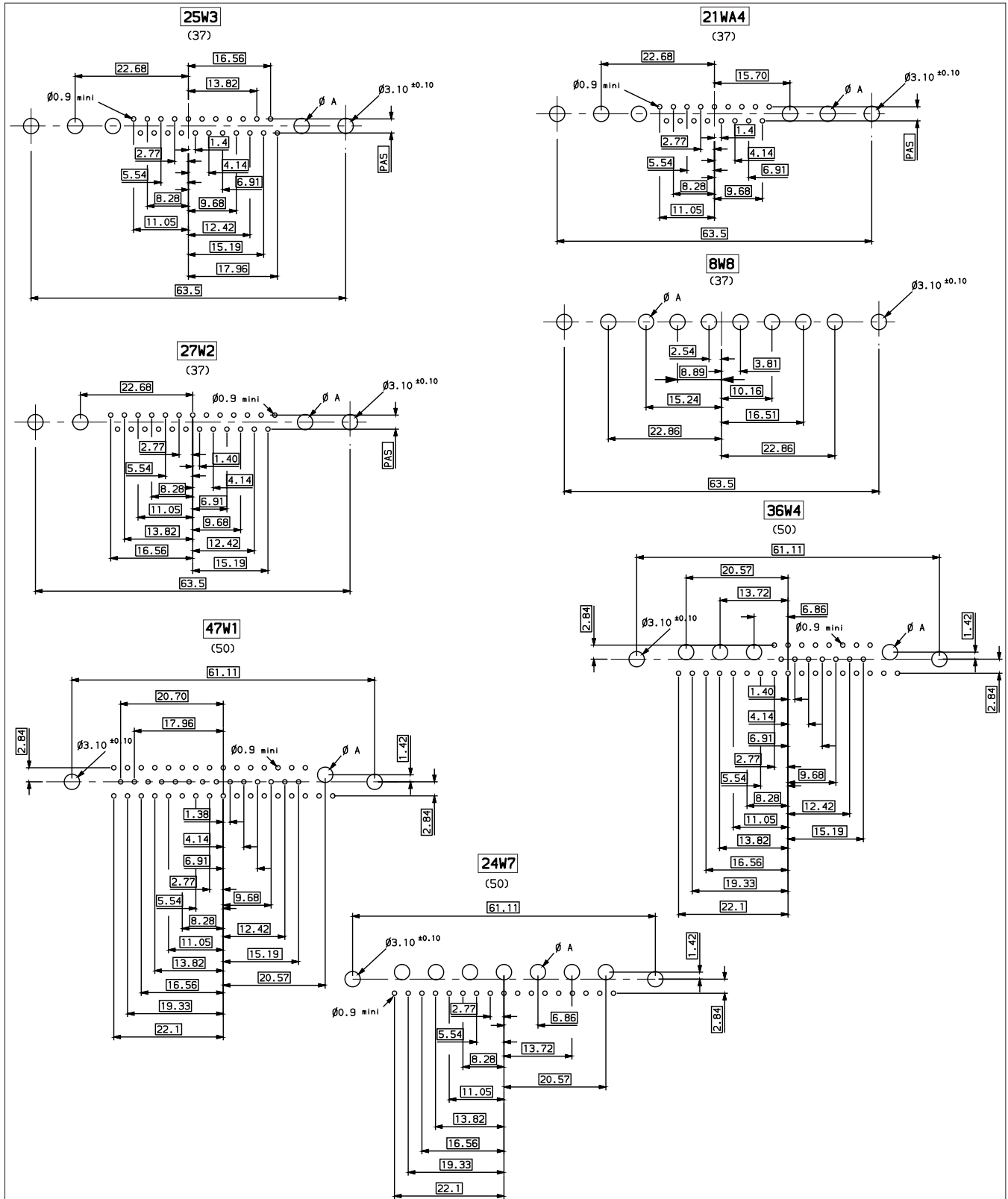

Mixed power DW series solder



Straight and right angle PC board versions



Ordering information

Series	D	B	L	13	W	3	P	3	00	G	30LF
Shell size (tin plated) E, A, B, C, D (only straight version)											
Options 1 (see page 61)											
	Blank	L	O	I	V	Blank : without accessory L : Threaded insert M3 O : Threaded insert UNC 4-40 I : Female screw M3 V : Female screw UNC 4-40					
Straight version		X	X	X	X						
Right angled	X	X	X	X	X						
X : Available											
Layout of contacts (see page 20) (for right angled versions, 47W1, 24W7, 36W4 non available)											
Contacts P : Pin S : Socket											
Termination type 3 : Straight version 5 : Right angled / Europe standard 7 : Right angled / US standard (5W1, 9W4 non available)											
Plating 00 : 200 Mating / unmating 43 : 500 Mating / unmating											
Options 2 (see page 62) PCB accessories											
	A	H	G	M	A : without accessory on PCB H : Locking device used for PCB thickness 2.4 mm G : Locking device used for PCB thickness 1.6 mm M : Metal brackets						
Straight version	X	X	X								
Right angled	X	X	X	X							
X : Available											
Power contacts 30LF : Fitted with power contacts 30 A, RoHS compatible 40LF : Fitted with power contacts 40 A, RoHS compatible 00LF : Without power contacts, RoHS compatible											

Mixed power DW series solder

Specific dimensions

Straight version

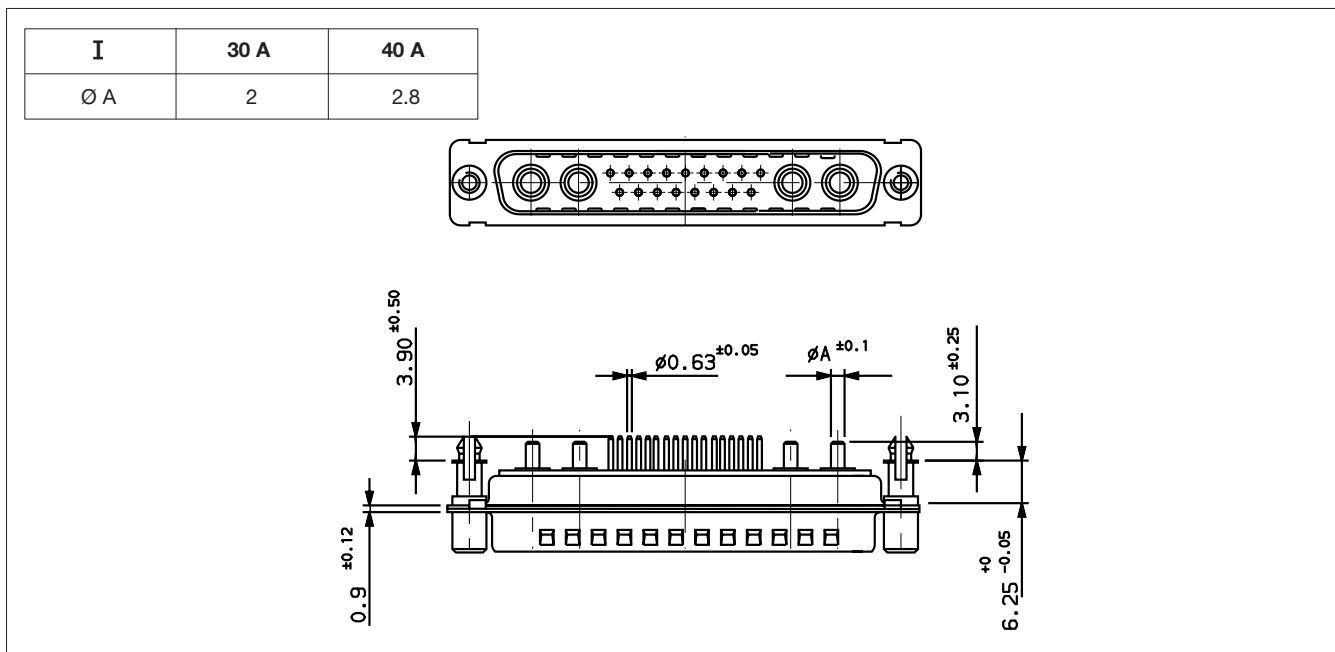

Angled version

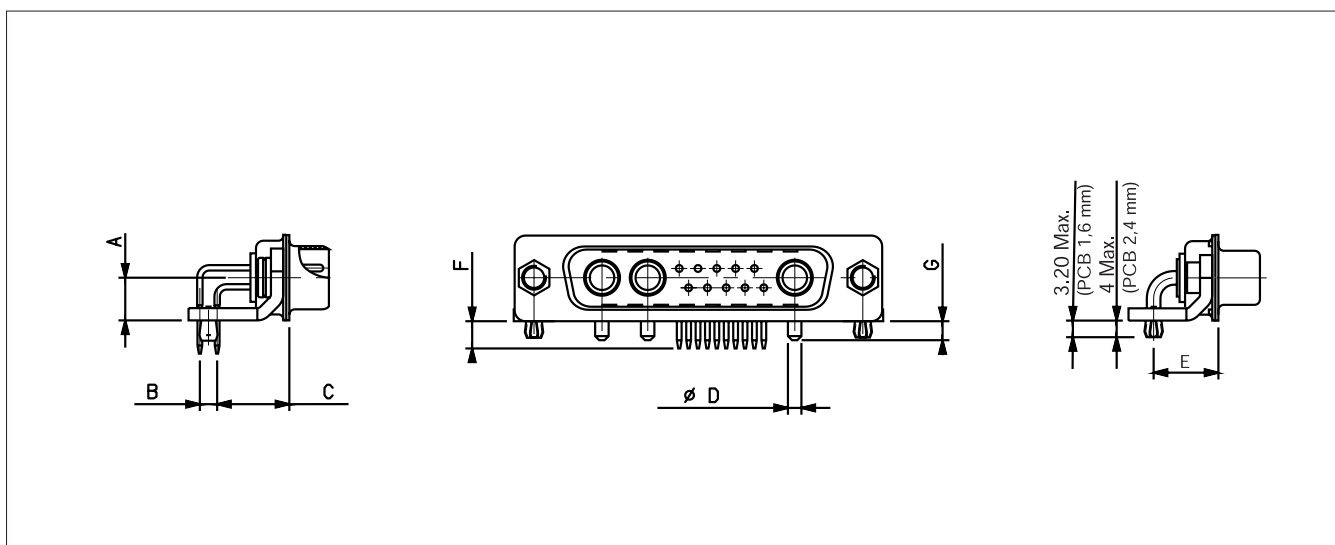

	Termination type	Amp.	A \pm 0.10	B \pm 0.20	C \pm 0.20	D \pm 0.10	E \pm 0.20	F \pm 0.50	G \pm 0.30
Europe	5...	30 A	7.20	2.54	10.30	2.00	11.65	4.00	3.60
		40 A	7.20	2.54	10.30	2.80	11.65	4.00	3.60
U.S	7...	30 A	6.30	2.84	8.08	2.00	9.50	3.90	3.60

Mixed power DW series Cable connectors

 UL Recognized File E 118235 (R)



Ordering information (power contacts have to be ordered separately – see next page)

Series	D	B	L	13	W	3	P	4	00	A	00LF
Shell size (tin plated) E, A, B, C, D											
Mounting option 1 (see page 61) connector accessories											
	Blank	L	O	I	V	F	☺				
Solder buckets	X	X	X	X	X	X	☺				
Wire wrap	X	X	X	X	X	X	☺				
X : Available											
Layout of contacts (see page 16)											
Contacts											
P											
S											
Termination type											
0											
4											
Plating											
00											
43											
A											
Power contacts											
00LF											

Mixed power DW series Cable connectors

Specific dimensions

Solder bucket

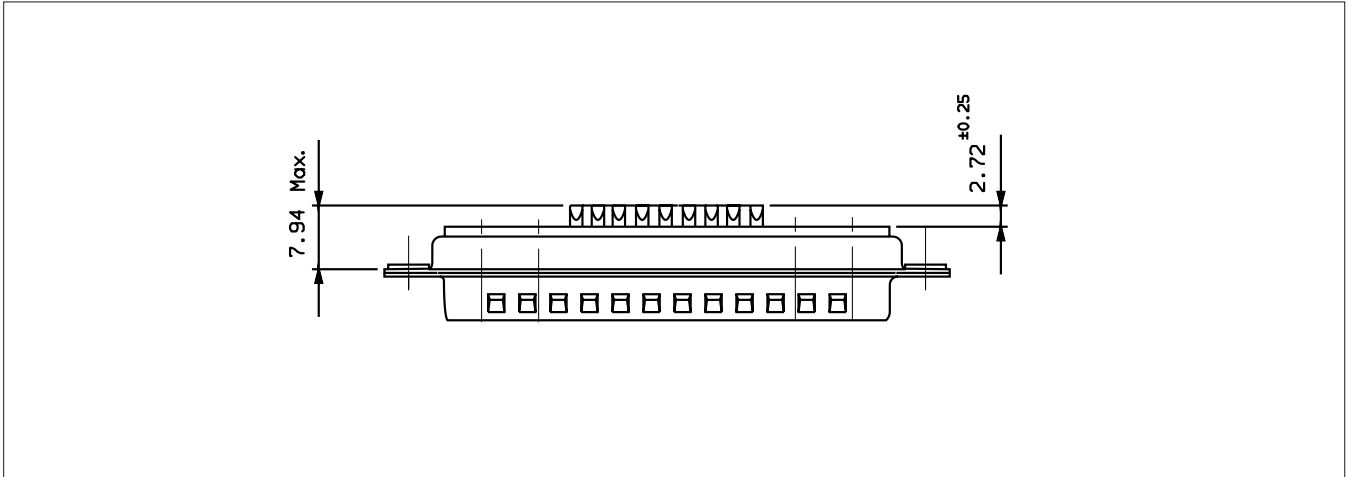

Wire wrap

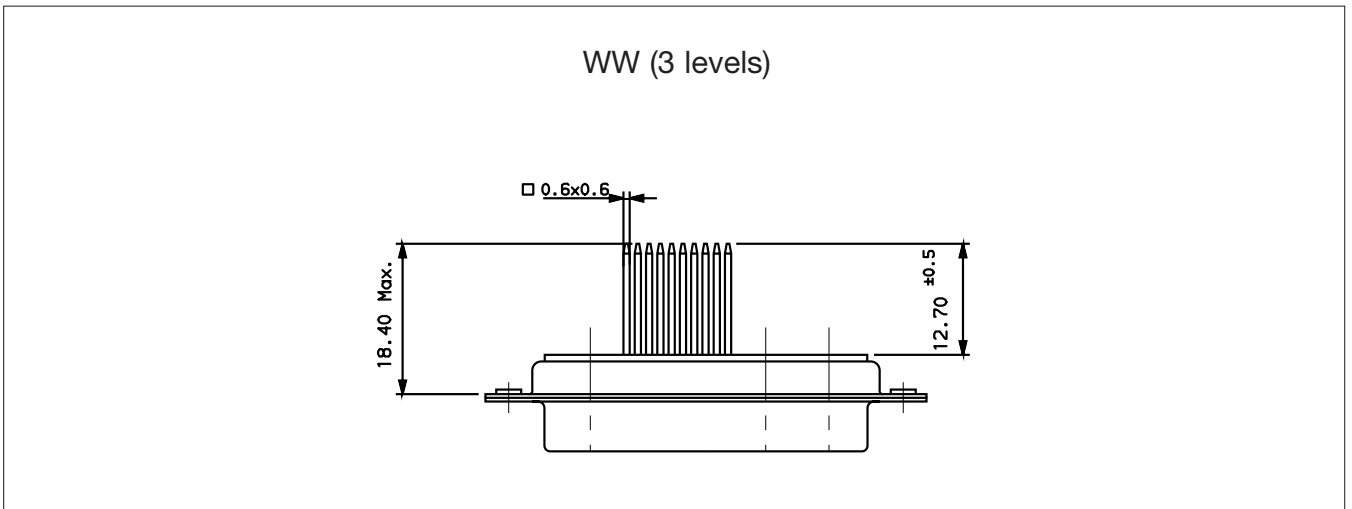

Solder version

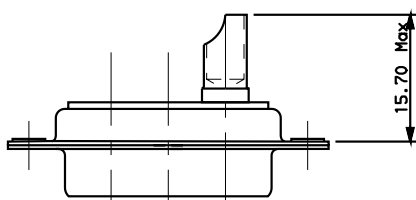

Crimp version

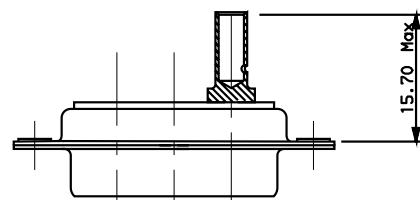

DW series Power solder and crimp

Power contacts

Solder contacts

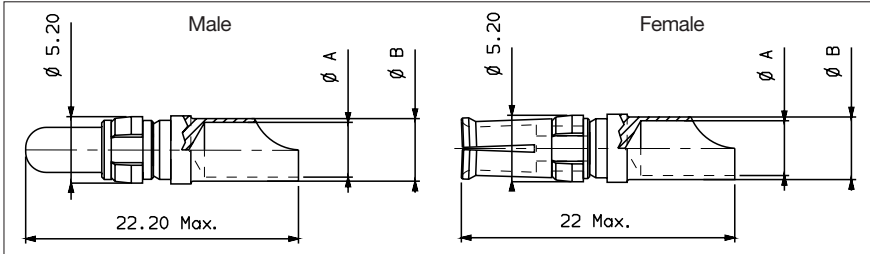

Type	Max. current rating	Clip colour	RoHS* Part number ≥ 200 mating/unmating	RoHS* Part number ≥ 500 mating/unmating	Wire		Strip length mm ^{+0.5} ₋₀	Ø A ^{+0.1}	Ø B ^{+0.05}
					Size	section mm ²			
Male	10A	Black	8638PPS1005LF	8638PPS1006LF	16	1.3	7	1.7	2.6
Male	15A	White	8638PPS1505LF	8638PPS1506LF	14	1.9	7	2.1	3
Male	20A	Red	8638PPS2005LF	8638PPS2006LF	12	3.2	7	2.8	3.65
Male	40A	Blue	8638PPS4005LF	8638PPS4006LF	8	9	7	4.4	5
Female	10A	Black	8638PSS1005LF	8638PSS1006LF	16	1.3	7	1.7	2.6
Female	15A	White	8638PSS1505LF	8638PSS1506LF	14	1.9	7	2.1	3
Female	20A	Red	8638PSS2005LF	8638PSS2006LF	12	3.2	7	2.8	3.65
Female	40A	Blue	8638PSS4005LF	8638PSS4006LF	8	9	7	4.4	5

- Clip material: plastic withstanding 125°C

- Termination plating: matt tin

* RoHS compatible EU directive 2002/95/EC

Crimp contacts

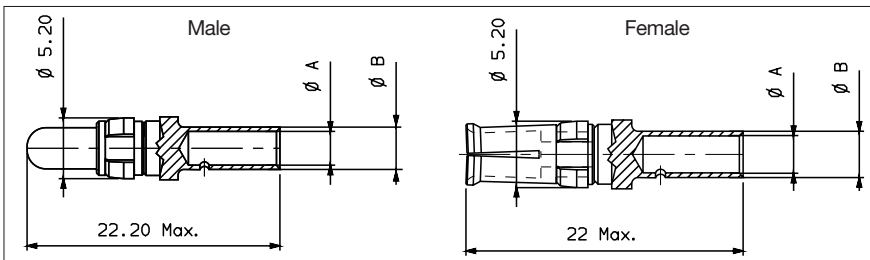

Type	Max. current rating	Clip colour	RoHS* Part number ≥ 200 mating/unmating	RoHS* Part number ≥ 500 mating/unmating	Wire		Strip length mm ^{+0.5} ₋₀	Ø A ^{+0.1}	Ø B ^{+0.05}
					Size	section mm ²			
Male	10A	Black	8638PPC1005LF	8638PPC1006LF	16 to 18	0.9 to 1.3	7	1.8	2.55
Male	20A	Red	8638PPC2005LF	8638PPC2006LF	12 to 14	2 to 3	7	2.8	3.7
Male	30A	White	8638PPC3005LF	8638PPC3006LF	9	6	7	3.75	4.65
Male	40A	Blue	8638PPC4005LF	8638PPC4006LF	8 to 10	5 to 8	7	4.8	5.5
Female	10A	Black	8638PSC1005LF	8638PSC1006LF	16 to 18	0.9 to 1.3	7	1.8	2.55
Female	20A	Red	8638PSC2005LF	8638PSC2006LF	12 to 14	2 to 3	7	2.8	3.7
Female	30A	White	8638PSC3005LF	8638PSC3006LF	9	6	7	3.75	4.65
Female	40A	Blue	8638PSC4005LF	8638PSC4006LF	8 to 10	5 to 8	7	4.8	5.4

- Clip material: plastic withstanding 125°C

- Termination plating: matt tin

* RoHS compatible EU directive 2002/95/EC

DELTA D





Full power right angle

 UL Recognized File E 118235 (R)

This monobloc insulator design with stamped and formed signal contacts combines performance and cost effectiveness.



Part number

Series	D	3	W	3	P	36 A	6	GX	08LF
		5	W	5					
Layout									
Contact									
P	: Male								
Termination type									
Code	Type	Foot print	Length of termination	PCB thickness					
36 A	Right angle, US standard, solder	8.08 mm	2.50	1.6					
Plating									
6	: High performances class (500 ≤ mating / unmating)								
Mounting options (see page 59)									
Options	Description								
GL	Harpoon + insert M3 + elec. continuity								
 GX	Harpoon + insert UNC 4-40 + elec. continuity								
 GV	Harpoon + Female screw UNC 4-40 + elec. continuity								
Power contacts									
 08	: Fitted with power contacts 30 A, non RoHS compatible								
 08LF	: Fitted with power contacts 30 A, RoHS compatible								

For other technical characteristics, see page 6 - For other dimensions and layouts, see page 18.

Specific dimensions

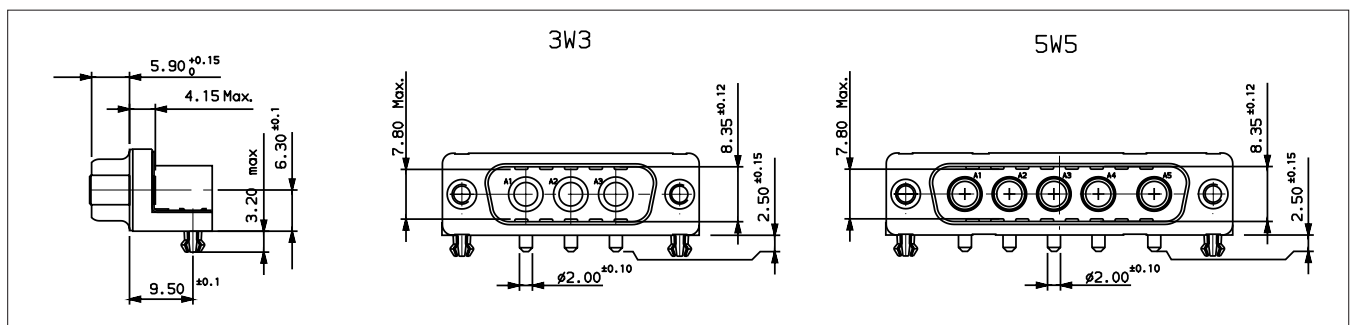

 Preferred option



DW series

Full power right angle and straight press-fit

 UL Recognized File E 118235 (R)

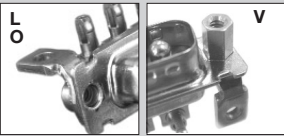
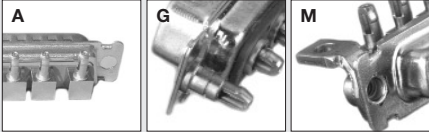

Part number

Series	D	E	L	2	V	2	P	93C	5	G	40LF															
Shell size (tin plated) E, A, B, C				3	V	3																				
Front accessory				5	W	3																				
				8	W	5																				
					W	8																				
Blank : Without accessory																										
L : Threaded insert M3																										
O : Threaded insert UNC 4-40																										
V : Female screw UNC 4-40																										
<table border="1"> <thead> <tr> <th></th> <th>Blank</th> <th>L</th> <th>O</th> <th>V</th> </tr> </thead> <tbody> <tr> <td>Straight version</td> <td></td> <td>X</td> <td>X</td> <td>X</td> </tr> <tr> <td>Right angled</td> <td>X</td> <td>X</td> <td>X</td> <td>X</td> </tr> </tbody> </table>		Blank	L	O	V	Straight version		X	X	X	Right angled	X	X	X	X											
	Blank	L	O	V																						
Straight version		X	X	X																						
Right angled	X	X	X	X																						
X : available																										
																										
Layout																										
Contacts																										
P : Pin																										
S : Socket																										
Termination type																										
93 C : Straight version																										
81 C : Right angle / European standard																										
80 C : Right angle / US standard																										
Plating																										
5 : 200 mating / unmating																										
6 : 500 mating / unmating																										
PCB accessory																										
<table border="1"> <thead> <tr> <th></th> <th>M</th> <th>G</th> <th>A</th> </tr> </thead> <tbody> <tr> <td>Straight version</td> <td></td> <td>X</td> <td></td> </tr> <tr> <td>Right angled</td> <td>X</td> <td></td> <td>X</td> </tr> </tbody> </table>		M	G	A	Straight version		X		Right angled	X		X														
	M	G	A																							
Straight version		X																								
Right angled	X		X																							
A : without accessory																										
G : Harpoon used for PCB thickness from 1.6 mm																										
M : Metal brackets without harpoon																										
																										
Power contacts																										
40 : Fitted with power contacts 40 A, non RoHS compatible																										
 40LF : Fitted with power contacts 40 A, RoHS compatible																										

For other technical characteristics, see page 6.

DW series

Full power right angle and straight press-fit

Specific dimensions

- Metallized hole dimensions

			Press-fit contacts	Press-fit harpoons	Other accessories
P.C.B. hole definition (note 1 and 2)		Drill diameter	$\varnothing 3.22 \pm 0.03$	$\varnothing 3.22 \pm 0.03$	$\varnothing 3,22 \pm 0,03$
		Drilled hole	$\varnothing 3.19 - 3.25$	$\varnothing 3.19 - 3.25$	
		Copper plating	25 μm min (recommended 50 μm max)	25 μm min (recommended 50 μm min)	
	non RoHS	Tin lead plating	15 μm max (recommended 5 μm min)	15 μm max (recommended 5 μm min)	
	RoHS	Finish hole (after reflow)	$\varnothing 3.02 - 3.20$	$\varnothing 3.02 - 3.20$	
		Tin plating	0.8 to 1.2 μm	0.8 to 1.2 μm	
Finish hole (after reflow)		$\varnothing 3.08 - 3.20$	$\varnothing 3.08 - 3.20$		

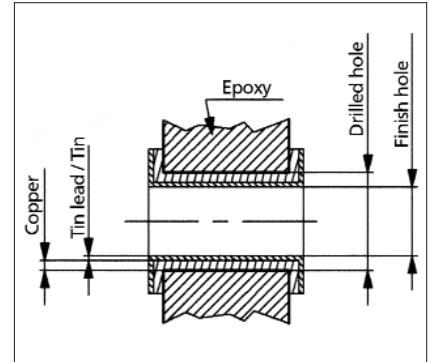

Note 1 : These dimensions must be respected to ensure press-fit pin performance

Note 2 : According to IEC-352-S specification

Note 3 : Vital requirement for press-fit pin performance

- Press-fit performance

	Press-fit contacts	Press-fit harpoons
Insertion force	$\leq 200 \text{ N}$ (average insertion 160N)	$\leq 200 \text{ N}$ (average insertion 160N)
Extraction force	$\geq 30 \text{ N}$	$\geq 30 \text{ N}$

8656 series



8656 series is a D connector with removable crimp contacts for AWG 20/24 or 24/28 wires. It is used for commercial cabling like computer equipment, cash registers... It accepts our standard accessories (hoods, locking devices) and is available with a complete range of crimping tools from hand tools to high volume production equipment.

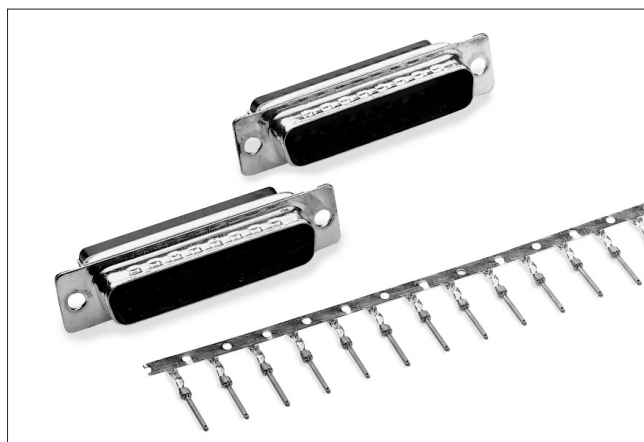

Ordering information

Connector part numbers

Series	8656	0	25	P	L	T	X	LF
Options 1 (see page 61)								
Blank	: Standard mounting hole (Ø = 3.10)							
O	: Clinch nuts UNC 4-40							
Number of contacts	9, 15, 25, 37, 50							
Contacts								
P	: Pin							
S	: Socket							
L	: Supplied without contacts (obligatory)							
Shell plating								
T	: Standard tin plating							
Dimples								
X	: Standard on male shell only							
Blank	: non RoHS compatible							
LF	: RoHS compatible							

Contact part numbers

Contact type \ Packaging type	Box of 500 contacts	Reel of 400 contacts	Reel of 5000 contacts	Reel of 10 000 contacts
AWG 24/28 male	8656 350 06 ▲	8656 3003 06 ▲	8656 4510 06 ▲	8656 4540 06 ▲
AWG 24/28 female	8656 351 06 ▲	8656 3004 06 ▲	8656 6510 06 ▲	8656 6540 06 ▲
AWG 20/24 male	8656 352 06 ▲	8656 3005 06 ▲	8656 4520 06 ▲	8656 4530 06 ▲
AWG 20/24 female	8656 353 06 ▲	8656 3006 06 ▲	8656 6520 06 ▲	8656 6530 06 ▲

▲ **Contact plating:** 4: ≥ 200 mating / unmating, non RoHS compatible
5: ≥ 500 mating / unmating, non RoHS compatible

☺ 4LF: ≥ 200 mating / unmating, RoHS compatible
☺ 5LF: ≥ 500 mating / unmating, RoHS compatible

8656 series

Specific dimensions

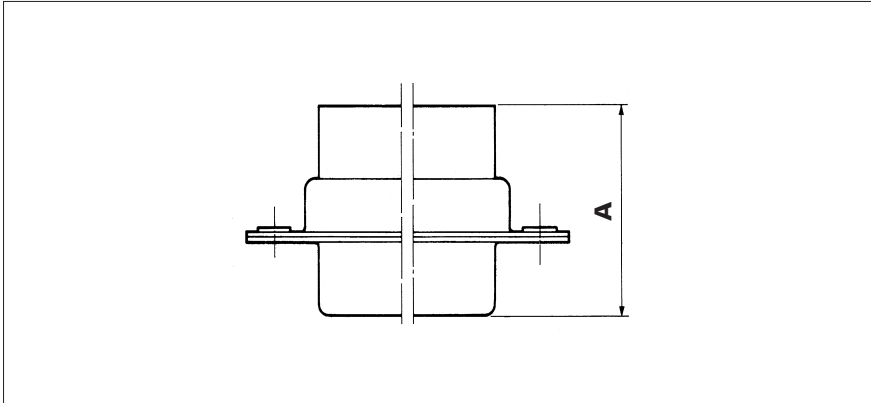

	09	15	25	37	50
Pin	17.19	17.19	17.35	17.35	17.35
A_{Max.}					
Socket	17.44	17.44	17.44	17.44	17.44

Cable preparation

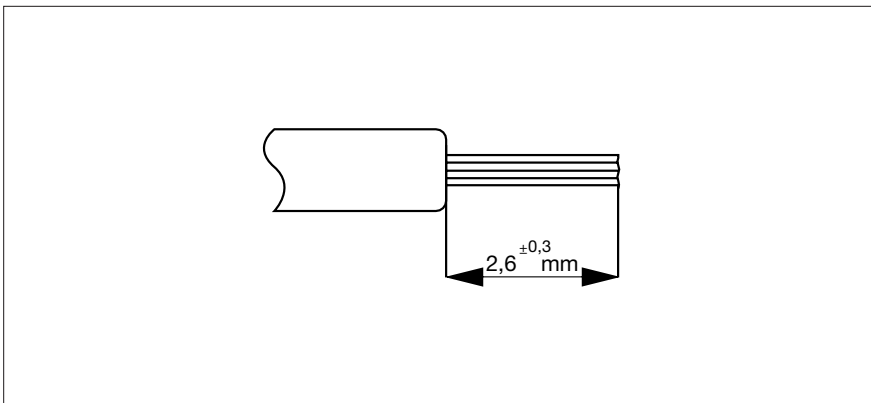

8657 series

Insulation displacement connection for flat cable,
multistrand (AWG 26/28) or single strand (AWG 28/30)



These connectors are suitable for input/output applications and interconnecting electronic equipment.



Ordering information

Series	8657	25	P	0	65	T	X	LF
Number of contacts 9, 15, 25, 37								
Contacts P : Pin S : Socket	} Stamped and rolled contacts							
Standard version								
Plating 65	: 500 mating / unmating							
Shell plating T	: Standard tin plating							
Dimples X	: Standard on male connector only							
☺ LF	: RoHS compatible							

Technical characteristics - see page 7

8657 series

Layouts

Male insulator front view

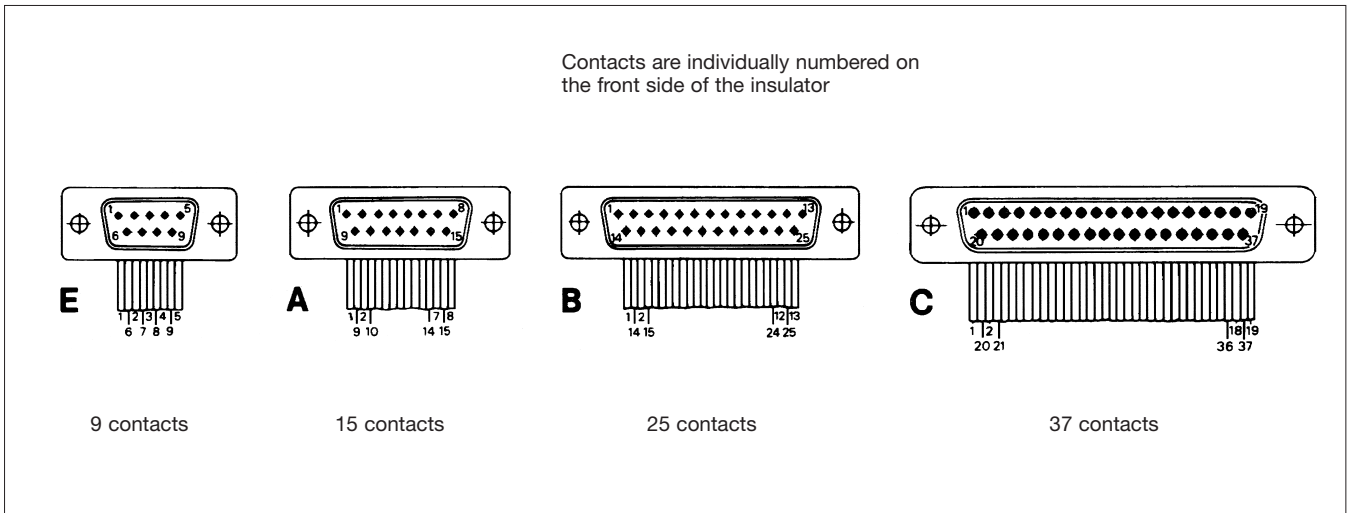

Specific dimensions

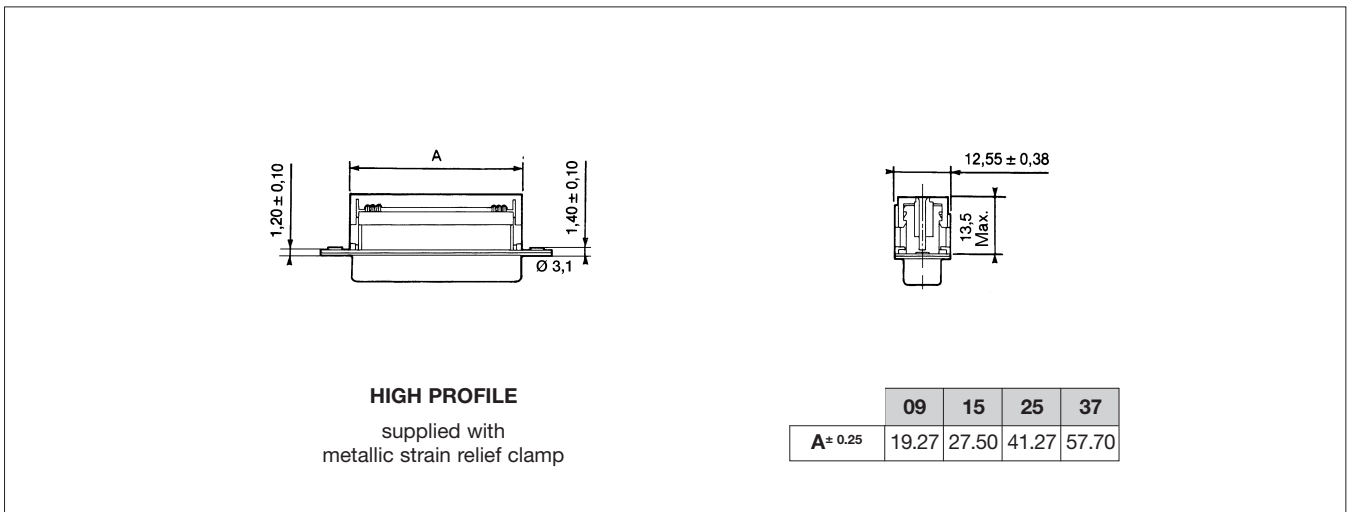

DP series



UL Recognized File E 118235

DP series is designed for high performance applications, particularly in the field of telecommunications: data transmission, private automatic branch switching, telecom (LNZ listed). It features machined contacts and is available with solder bucket, straight spills, angled spills, and wire wrap terminations.



Ordering information

Series	D	B	P	V	25	P	3	64	C	T	X	LF
Shell size E, A, B, C, D												
P : Characterisation of DP series												
Front accessories Blank : Standard mounting holes (Ø = 3.10) L : Clinch nuts M3 V : Female screw locks UNC 4-40 S : Spacers (straight spills only)												
Number of contacts 09, 15, 25, 37, 50												
Contacts P : Pin S : Socket												
Termination 0 : Solder buckets (blank for plating 00) 3 : Straight spills 5 : Angled spills- 2.54 mm between rows 8 : Angled spills- 2.84 mm between rows 4 : Wire wrap (3 levels) 6 : Wire wrap (2 levels)												
Plating 64 : ≥ 200 mating / unmating 65 : ≥ 500 mating / unmating, blank for solder bucket termination												
PCB accessories												
Index	Termination type	Straight spills	Angled spills	Solder buckets	Wire wrap							
Blank		Without accessory	Two plastic brackets*	Without accessory	Without accessory							
C			Without bracket									
M			Two metal brackets									
G		Harpoons	Harpoons									
		(Compulsary with option L or V)	(9 to 37 ways only)									
H				Shielding termination fingers								
* Except 50 pos. with monobloc plastic brackets												
Shell plating T : Standard tin plated												
Dimples X : Standard on male connectors only												
Blank : Standard series, non RoHS compatible LF : Standard series, RoHS compatible												

Technical characteristics – page 7

DP series

Specific dimensions

Solder buckets

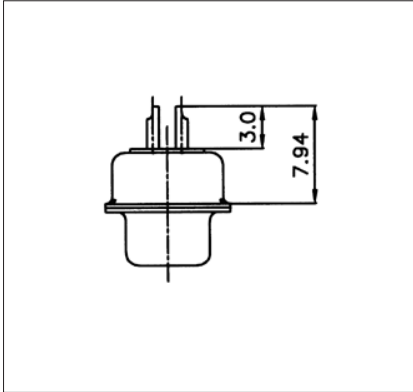

Wire wrap

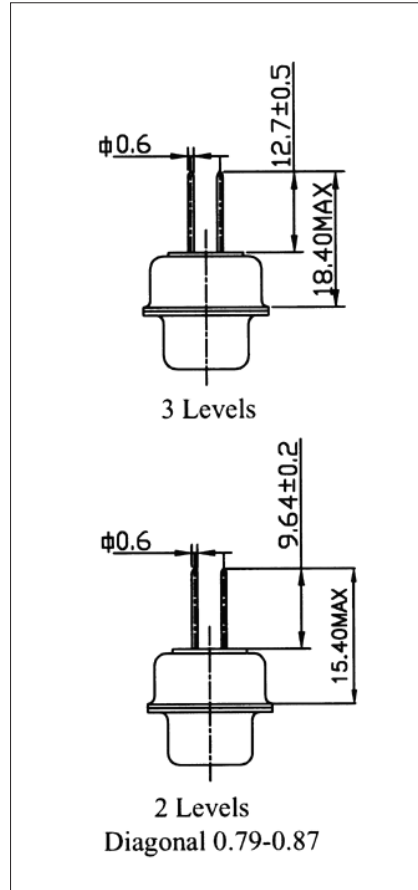

Angled spills

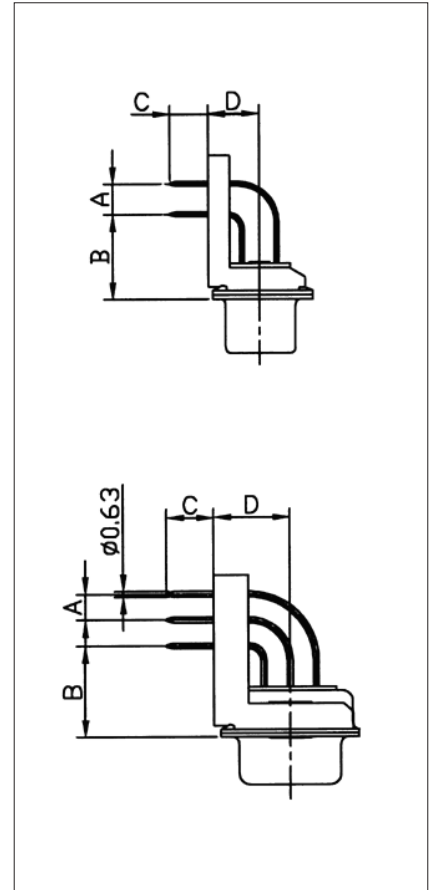

Straight spills

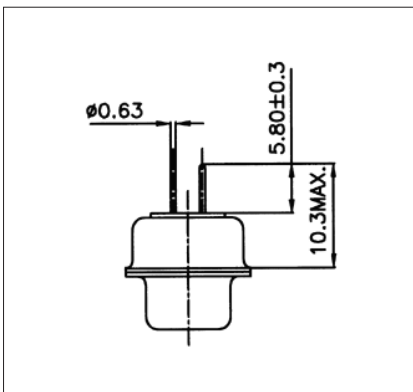

Termination		5	8
		Dimension	
A		2.54	2.84
B ± 0.1		10.30	10.30
C ± 0.5		4.00	4.00
D ± 0.1	9 to 37 contacts	7.20	7.20
	50 contacts	8.60	8.60

DM series HE 501



UL Rating Product File E 118235 (R)

For aerospace, military 125° class-European standard in compliance with NFC 93425 / HE 501.

Shell plating: Cadmium



Ordering information

Series	D	B	M	L	25	P	5	00	M	LF														
Shell size E, A, B, C, D																								
M: Characterisation of Military series																								
Options 1 (see cover page 59) Blank : Standard mounting holes ($\varnothing = 3.10$) L : Clinch nuts M3 F : Float mounting																								
Number of contacts 09, 15, 25, 37, 50																								
Contacts P : Pin S : Socket																								
Termination Blank : Solder buckets 3 : Straight solder spills 5 : Angled solder spills 4 : Wire wrap (3 levels)																								
Plating 00 : Standard = Gold / Nickel - Blank for solder bucket termination Others : please, consult us																								
Options 2 (see cover page 62)																								
<table border="1"> <thead> <tr> <th>Option</th> <th>Version</th> <th>Angled spills</th> <th>Other terminations</th> </tr> </thead> <tbody> <tr> <td rowspan="3">Blank C M</td> <td>Blank</td> <td>Plastic brackets</td> <td>Not applicable</td> </tr> <tr> <td>C</td> <td>Without brackets</td> <td>Not applicable</td> </tr> <tr> <td>M</td> <td>Metal brackets</td> <td>Not applicable</td> </tr> </tbody> </table>	Option	Version	Angled spills	Other terminations	Blank C M	Blank	Plastic brackets	Not applicable	C	Without brackets	Not applicable	M	Metal brackets	Not applicable										
Option	Version	Angled spills	Other terminations																					
Blank C M	Blank	Plastic brackets	Not applicable																					
	C	Without brackets	Not applicable																					
	M	Metal brackets	Not applicable																					
Blank : non RoHS compatible LF : RoHS compatible																								

DM series HE 501

Specific dimensions

Solder buckets

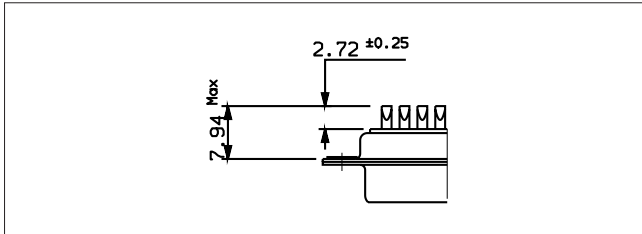

Cross reference list for the main HE 501 and FCI

Connector type			HE 501	FCI
Solder buckets	Standard	M	HE 501 N..AP3	D.M..PLF
		F	HE 501 N..AS3	D.M..SLF
	Float mounting	M	HE 501 F..AP3	D.MF..PLF
		F	HE 501 F..AS3	D.MF..SLF

Straight spills

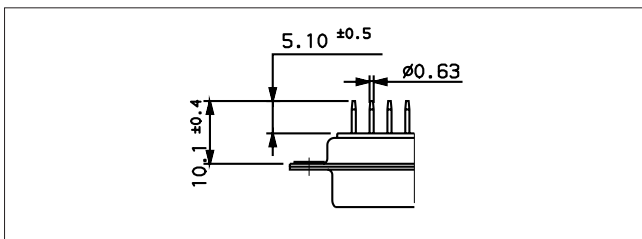

Connector type			HE 501	FCI
Straight spills	Standard	M	HE 501 N..YP4.3	D.M..P 300LF
		F	HE 501 N..YS4.3	D.M..S 300LF
	Float mounting	M	HE 501 F..YP4.3	D.MF..P 300LF
		F	HE 501 F..YS4.3	D.MF..S 300LF

Wire wrap

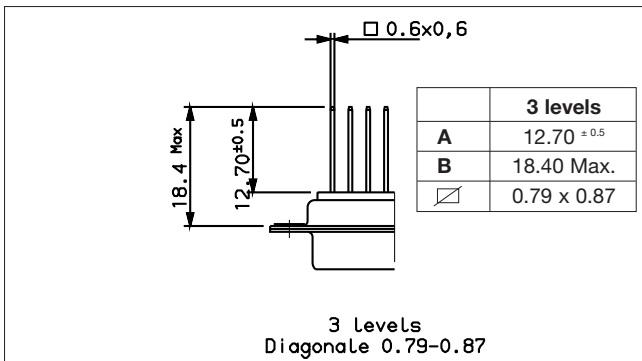

Connector type			HE 501	FCI
Wire wrap 3 levels	Standard	M	HE 501 N..KP3.3	D.M..P 400LF
		F	HE 501 N..KS3.3	D.M..S 400LF
	Float mounting	M	HE 501 F..KP3.3	D.MF..P 400LF
		F	HE 501 F..KS3.3	D.MF..S 400LF

Angled spills

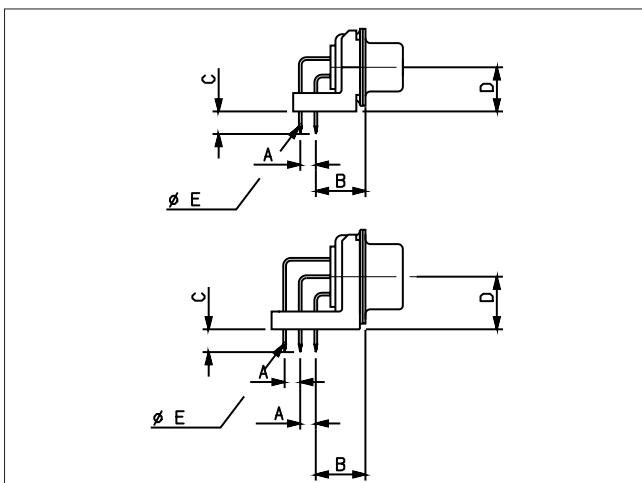

Connector type			HE 501	FCI
Angled spills 500	Standard	M	HE 501 P..VP6.3	D.M..P 500LF
		F	HE 501 P..VS6.3	D.M..S 500LF
	Metal brackets	M	HE 501 M..VP6.3	D.M..P 500MLF
		F	HE 501 M..VS6.3	D.M..S 500MLF

Dimension	Termination	5
A		2.54
B ±0.1		10.30
C ±0.5		4.00
D ±0.1	9 to 37 contacts	7.20
	50 contacts	8.60
Ø E		0.63

DM series HE 508



UL Rating Product File E 118235 (R)

For particularly severe applications, especially high temperatures class + 155°C in compliance with NFC 93425 / HE 508.

Shell plating: Cadmium



Ordering information

Series	D	B	M	25	P	5	00	M	N	LF
Shell size E, A, B, C, D										
M: Characterisation of Military series										
Options 1 (see cover page 61) Blank : Standard mounting holes (Ø = 3.10) F : Float mounting										
Number of contacts 09, 15, 25, 37, 50										
Contacts P: Pin S: Socket										
Termination Blank : Solder buckets 3 : Straight solder spills 5 : Angled solder spills 4 : Wire wrap (3 levels)										
Plating 00 : Standard = Gold / Nickel (blank for solder buckets termination) Others : please, consult us										
Options 2 (see cover page 62)										
Option \ Version	Angled spills		Other terminations							
Blank	Plastic brackets		Not applicable							
C	Without brackets		Not applicable							
M	Metal brackets (male only)		Not applicable							
N: Obligatory for HE 508										
Blank : non RoHS compatible LF : RoHS compatible										

DM series HE 508

Specific dimensions

Solder buckets

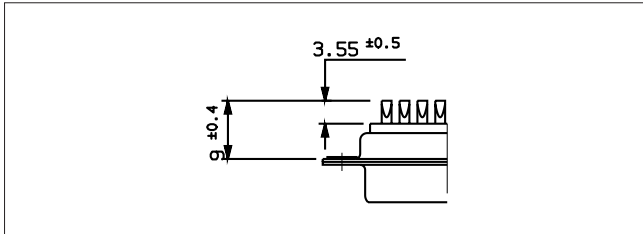

Cross reference list for the main HE 508 and FCI

Connector type			HE 508	FCI
Solder buckets	Standard	M	HE 508 N..AP	D.M..PNLF
		F	HE 508 N..AS	D.M..SNLF
	Float mounting	M	HE 508 F..AP	D.MF..PNLF
		F	HE 508 F..AS	D.MF..SNLF

Straight spills

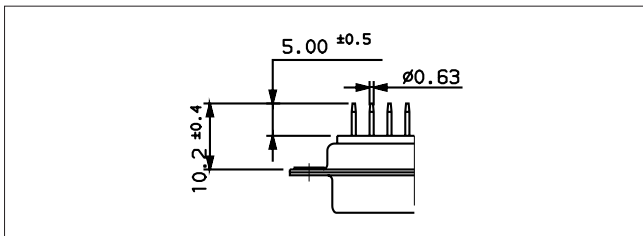

Connector type			HE 508	FCI
Straight spills	Standard	M	HE 508 N..YP4	D.M..P 300NLF
		F	HE 508 N..YS4	D.M..S 300NLF
	Float mounting	M	HE 508 F..YP4	D.MF..P 300NLF
		F	HE 508 F..YS4	D.MF..S 300NLF

Wire wrap

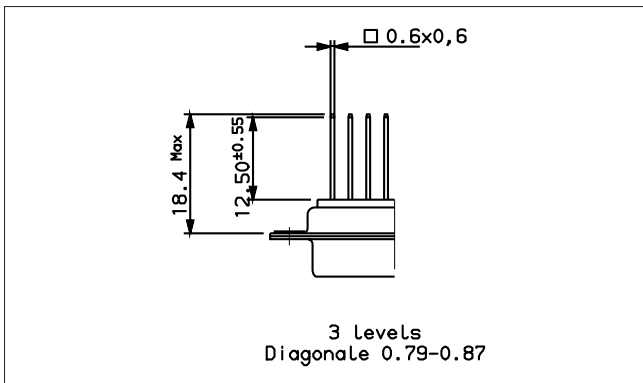

Connector type			HE 508	FCI
Wire wrap 3 levels	Standard	M	HE 508 N..KP3	D.M..P 400NLF
		F	HE 508 N..KS3	D.M..S 400NLF
	Float mounting	M	HE 508 F..KP3	D.MF..P 400NLF
		F	HE 508 F..KS3	D.MF..S 400NLF

Angled spills

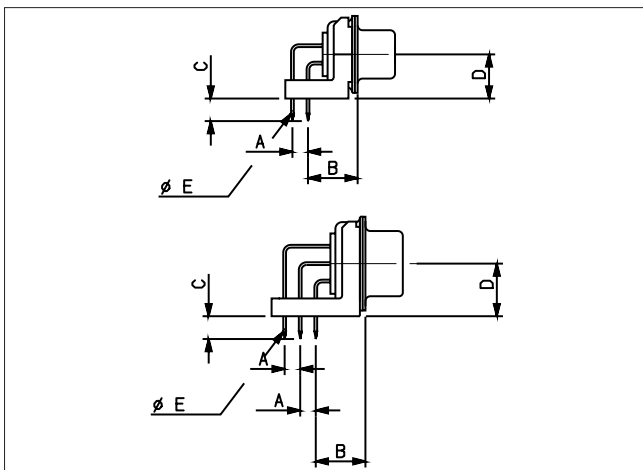

Connector type			HE 508	FCI
Angled spills 500	Standard	M	HE 508 P..VP6	D.M..P 500NLF
		F	HE 508 P..VS6	D.M..S 500NLF
	Metal brackets	M	HE 508 M..VP6	D.M..P 500MNLF
		F	HE 508 M..VS6	D.M..S 500MNLF

Dimension	Termination	5
A		2.54
B ±0.1		10.30
C ±0.5		4.00
D ±0.1	9 to 37 contacts	7.20
	50 contacts	8.60
Ø E		0.63

DMW series HE 507



UL Rating Product File E 118235

Connectors drawn from DM series. Composed of mixed arrangements of standard signal and size 8 cavities housing, coax, power, high voltage and optical removable contacts (see page ??).

Shell plating: Cadmium



Ordering information

Series	D	B	M	13W3	P	5	00	M	N	LF																
Shell size E, A, B, C, D																										
M: Characterisation of military series																										
Options 1 (see cover page 61) Blank : Standard mounting holes (Ø = 3.10) F : Float mounting																										
Layout of contacts see page 45																										
Contacts P : Pin S : Socket																										
Terminaison Blank : Solder buckets 3 : Straight solder spills 5 : Angled solder spills 4 : Wire wrap (3 levels)																										
Plating 00 : Standard = Gold / Nickel on active areas - Tin lead on termination (blank for solder buckets termination)																										
Options 2 (see cover page 62)																										
<table border="1"> <thead> <tr> <th>Option</th> <th>Version</th> <th>Angled spills</th> <th>Other terminations</th> </tr> </thead> <tbody> <tr> <td>Blank</td> <td></td> <td>Plastic brackets</td> <td>Without accessory</td> </tr> <tr> <td>C</td> <td></td> <td>Without brackets</td> <td>Not applicable</td> </tr> <tr> <td>M</td> <td></td> <td>Metal brackets</td> <td>Not applicable</td> </tr> </tbody> </table>	Option	Version	Angled spills	Other terminations	Blank		Plastic brackets	Without accessory	C		Without brackets	Not applicable	M		Metal brackets	Not applicable										
Option	Version	Angled spills	Other terminations																							
Blank		Plastic brackets	Without accessory																							
C		Without brackets	Not applicable																							
M		Metal brackets	Not applicable																							
N: Compulsary in compliance with HE 507																										
Blank : non RoHS compatible LF : RoHS compatible																										

DMW series HE 507

Layouts

Male insulator front view

Shell size	Layout	
E	5W1	
	11W1	
A	7W2	
	3W3	
	3V3	
B	21W1	
	17W2	
	13W3	
	9W4	
	5W5	

Shell size	Layout	
C	25W3	
	21WA4	
	27W2	
	8W8	
D	47W1	
	24W7	
	36W4	

- Standard contacts
- Coaxial and power contacts

Specific dimension for standard terminations, see DM series, page 43

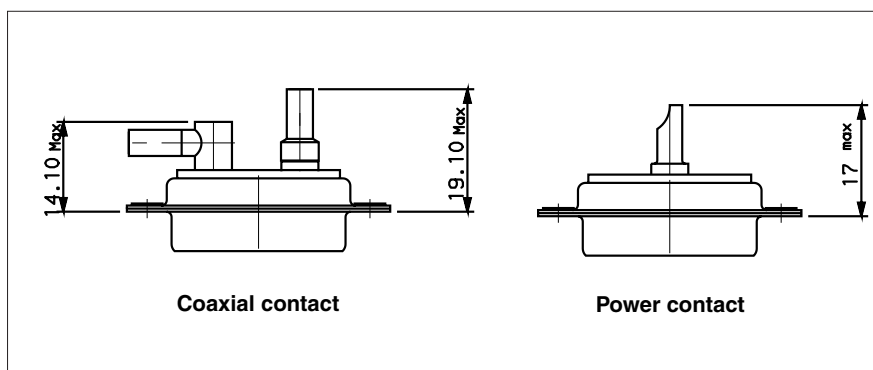

DMW series HE 507

Power contacts

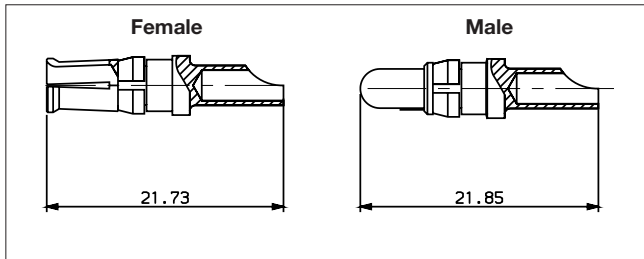

Wire Size	Max. current	Part numbers	
		Male	Female
AWG8	40A	86303098NLF	86303099NLF
AWG12	20A	86303056NLF	86303057NLF
AWG14	15A	86303060NLF	86303061NLF
AWG16	10A	86303064NLF	86303065NLF

Plating: 500 mating/unmating

High voltage contacts

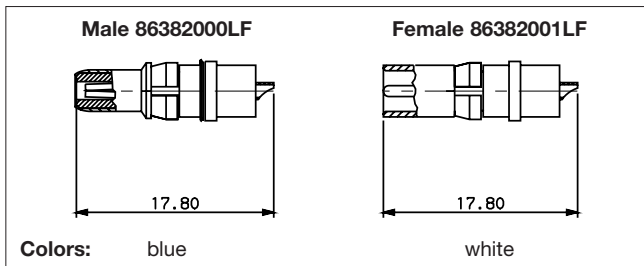

These removable contacts are suitable for the contact cavities of the DMW series and DW series.

The coaxial contacts are in compliance with:
 - NFC 93569
 - KMX4 specification

Electrical characteristics:

Dielectric with standing voltage	: 2800 V.r.m.s
Break down voltage	: 3200 V.r.m.s
Insulation resistance	: 10^9 M Ω
Contact resistance	: ≤ 5 m Ω
Max current rating	: 5A
Material	: TEFLON

Mechanical characteristics:

Mating force per set of contact	: 3N
Mating endurance	: 200
Temperature	: -55° C to + 125° C

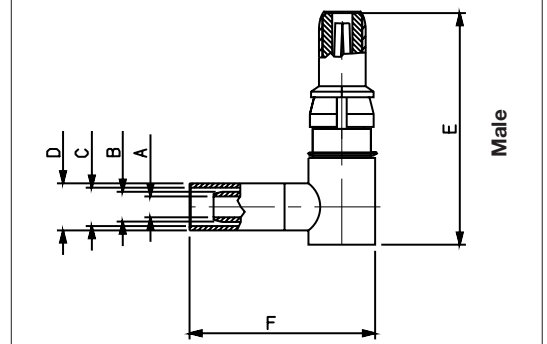
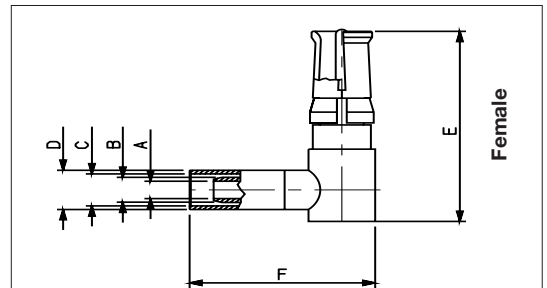
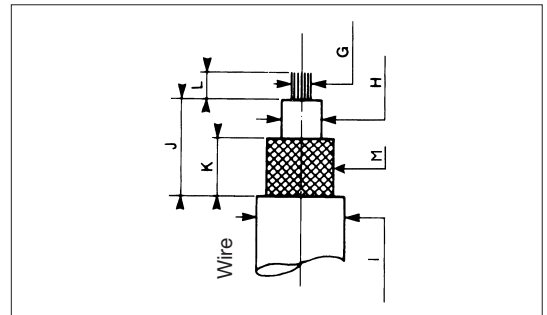

Angled

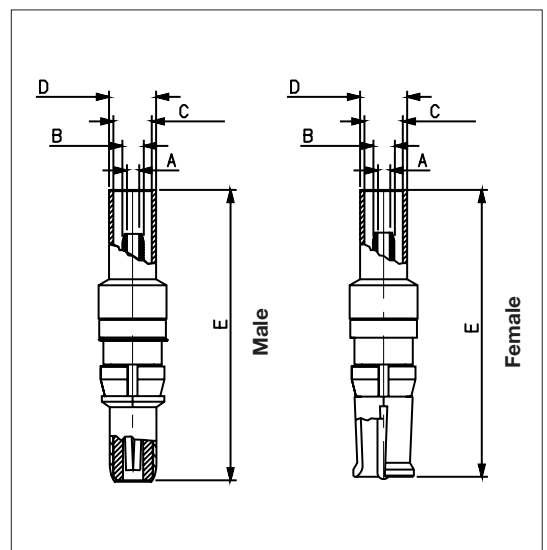

Coaxial contacts
Straight

DMW series HE 507

Standard coaxial contacts

Contact type	Part numbers				Contacts dimension						Cable				Wire						
	Soldered screen	NFC 93569 KMX4	Crimped screen	NFC 93569 KMX4	A ±0.10	B ±0.15	C ±0.02	D ±0.05	E ±0.04	F ±0.04	MILC 17E	NFC 93550	Impe-dance	G	H	I	J	K	L	M (Max.)	
Straight	male	DM537405000NCLF	KMX4M11D02	DM53740NCLF	KMX4M12D02				23.60								7.90	6.35	2	1.40	
	male	DM537405008NCLF	-	-	-				21.80												
	female	DM537425000NCLF	KMX4F11D02	DM53742NCLF	KMX4F12D02	1	1.75	2.32	3.20	23.60	RG 178BU	KX21A	50Ω±2	0.30	0.90	1.80					
	female	DM537425006NCLF	-	-	-				21.80												
Angled	male	DM537415000NCLF	KMX4M11C02	DM53741NCLF	KMX4M12C02				18.64	15.30							9.50	5.95	1.60		
	female	DM537435000NCLF	KMX4F11C02	DM537432NCLF	KMX4F12C02				18.64	15.30											
Straight	male	DM537405001NCLF	KMX4M11D01	DM537401NCLF	KMX4M12D01				23.60								7.90	6.35	2.00	2.05	
	female	DM537425001NCLF	KMX4F11D01	DM537421NCLF	KMX4F12D01	1.70	2.46	3	3.84	23.60	RG 316U	KX22A	50Ω±2	0.50	1.50	2.50					
Angled	male	DM537415001NCLF	KMX4M11C01	DM537411NCLF	KMX4M12C01				18.64	15.30							9.50	5.95	1.60		
	female	DM537435001NCLF	KMX4F11C01	DM537433NCLF	KMX4F12C01				18.64	12.50											

Specific coaxial contacts

Contact type	Part numbers				Contacts dimension						Cable				Wire					
	Soldered screen	NFC 93569 KMX4	Crimped screen	NFC 93569 KMX4	A ±0.10	B ±0.15	C ±0.02	D ±0.05	E ±0.04	F ±0.04	MILC 17E	NFC 93550	Impe-dance	G	H	I	J	K	L	M (Max.)
Straight	male	DM537405002NCLF	-	DM53740-3NCLF	-				26.30								9.70	7.90	2	3.14
	female	DM537425002NCLF	-	DM53742-3NCLF	-				26.30					95Ω±2	2.60	3.58				
Straight	male	DM537405005NCLF	-	DM53740-5NCLF	-				23.60								9.50		2	3.81
	female	DM537425004NCLF	-	DM53742-5NCLF	-	3.15	4.40	5.45	5.95	23.60	RG 58CU	KX15	50Ω±2	0.90	2.95	4.95		7.9		
Angled	female	DM537435004NCLF	-	DM53743-6NCLF	-				18.64	17.50							10.70		2.40	

D-Sub Accessories

1 • Straight exit plastic and metalised hood with integrated locking

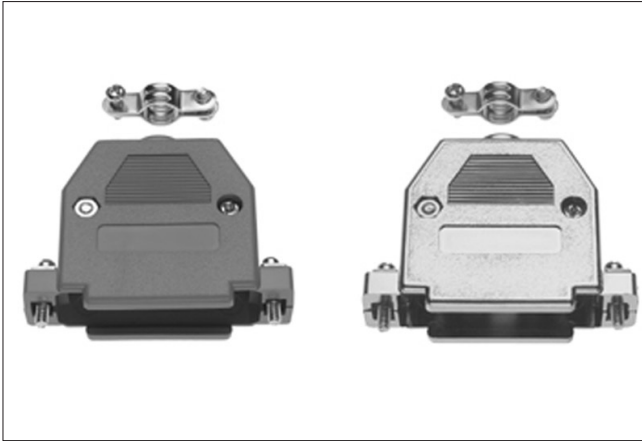

Material : self extinguishing UL 94V0 thermoplastic
 Colour : black / metalised
 Temperature range : -55°C +105°C
 Locking screws : UNC 4-40 thread

Shell size E (9 way)

- Plastic hood : part number : 10039449-00001LF
- Metalised hood : part number : 10039449-00002LF

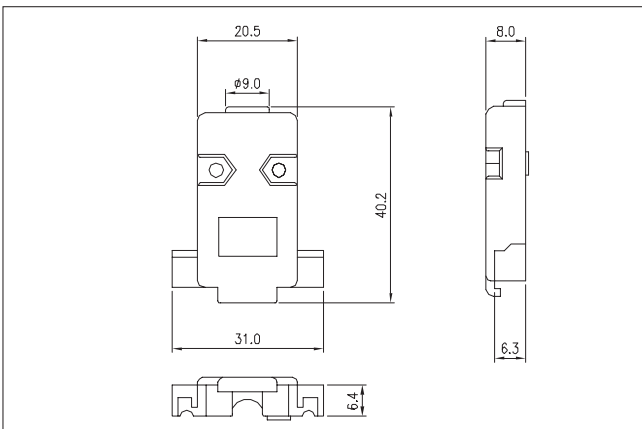

Shell size A (15 way)

- Plastic hood : part number : 10039450-00001LF
- Metalised hood : part number : 10039450-00002LF

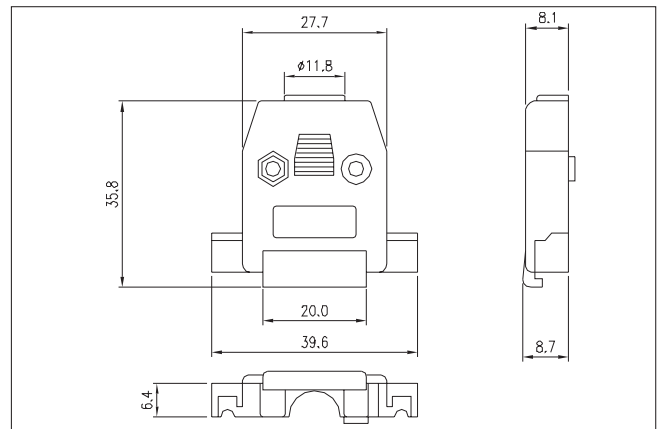

Shell size B (25 way)

- Plastic hood : part number : 10039451-00001LF
- Metalised hood : part number : 10039451-00002LF

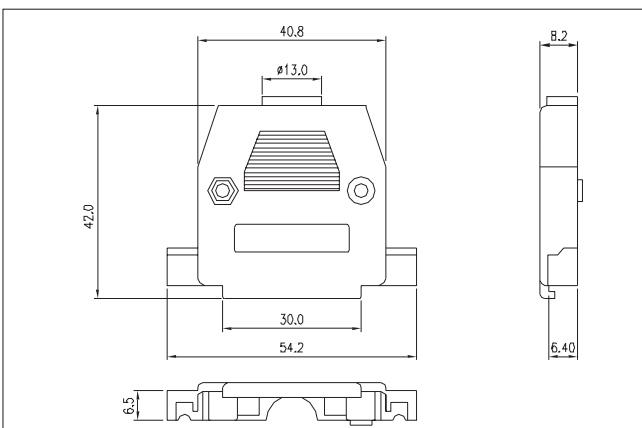

Shell size C (37 way)

- Plastic hood : part number : 10039452-00001LF
- Metalised hood : part number : 10039452-00002LF

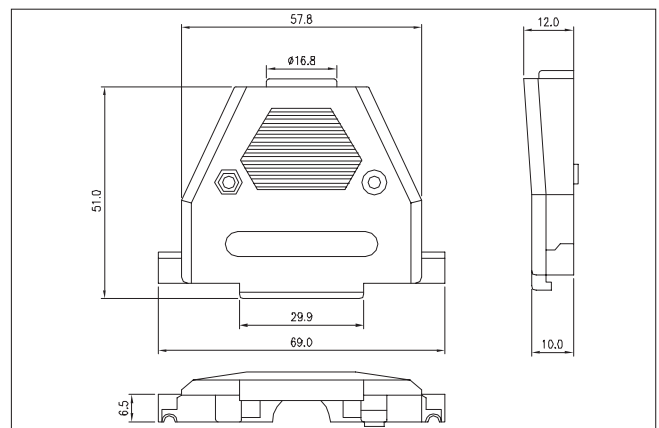

D-Sub Accessories

Straight exit plastic and metalised hood with integrated locking

Shell size D (50 way)

- Plastic hood : part number : 10039453-00001LF
- Metalised hood : part number : 10039453-00002LF

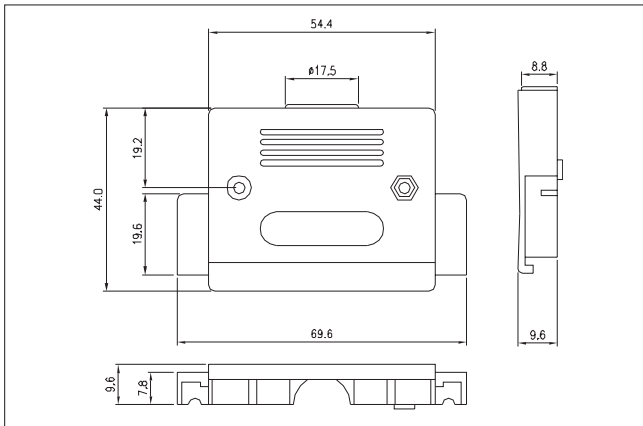

2 • Angle exit plastic hood for cable EMI/RFI



Shell size	Part number	A	B	Cable diameter
E (9)	8655PHRA0901LF	31.0	36.2	4 to 13 mm
A (15)	8655PHRA1501LF	39.5	40.2	
B (25)	8655PHRA2501LF	53.0	40.2	
C (37)	8655PHRA3701LF	69.5	40.2	

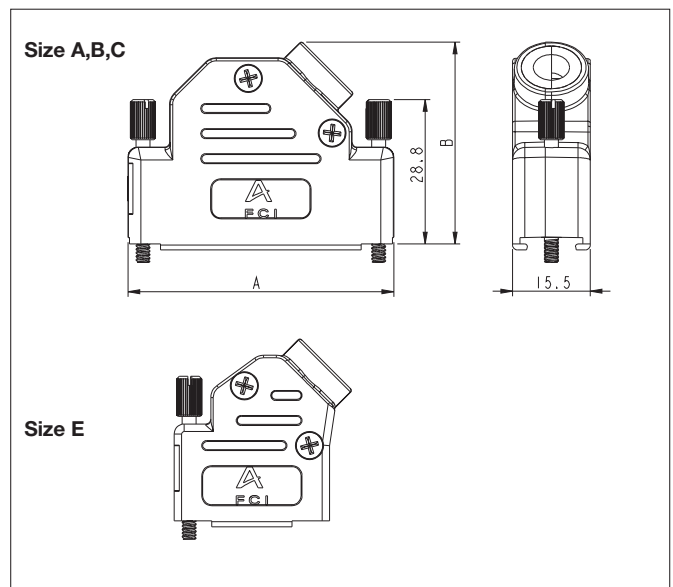

- Material : polycarbonat UL 94V0
- Cable strain relief : steel fibre reinforced polycarbonat UL 94V0
- Colour : black
- Temperature range : -40°C +120°C
- Environment : >40 dB between 30 MHz and 1 GHz
- Packaging : bulk, in box of 100 pieces
- Locking screws : UNC 4-40 thread

All dimensions in mm

D-Sub Accessories

3 • Straight exit metal hood with two metal clamps for cable EMI / RFI

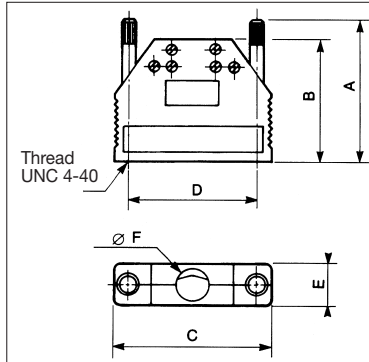
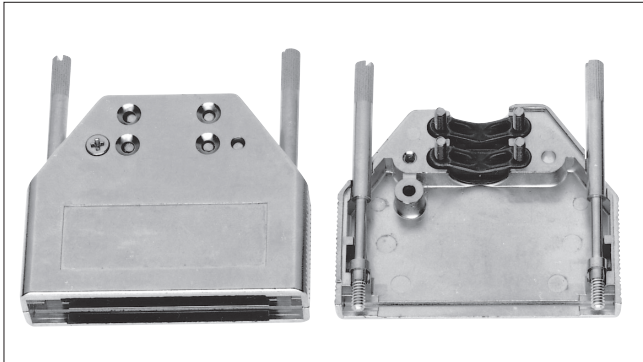

Material:
zamack
Plating:
nickel
Environment:
frequencies at 100 Mz > 40 dB
Corrosion resistance:
50 hours exposure to salt spray

Shell size	Part numbers in bulk	Packaging	Part numbers (in individual set)	Packaging	A ^{±0.1}	B ^{±0.3}	C ^{±0.1}	D ^{±0.1}	E ^{±0.2}	F max.
E	8655MH0901LF	80	8655MH0911LF	50	55.00	45.00	34.40	24.99	14.70	7.85
A	8655MH1501LF	80	8655MH1511LF	50	55.00	45.00	42.70	33.32	14.70	11.80
B	8655MH2501LF	60	8655MH2511LF	50	55.00	45.00	56.70	47.04	14.70	11.80
C	8655MH3701LF	40	8655MH3711LF	50	55.00	45.00	72.95	63.50	14.70	11.80
D	8655MH5001LF	40	8655MH5011LF	50	55.00	45.00	70.60	61.11	17.30	14.10

4 • Angle exit metal hood for cable EMI / RFI

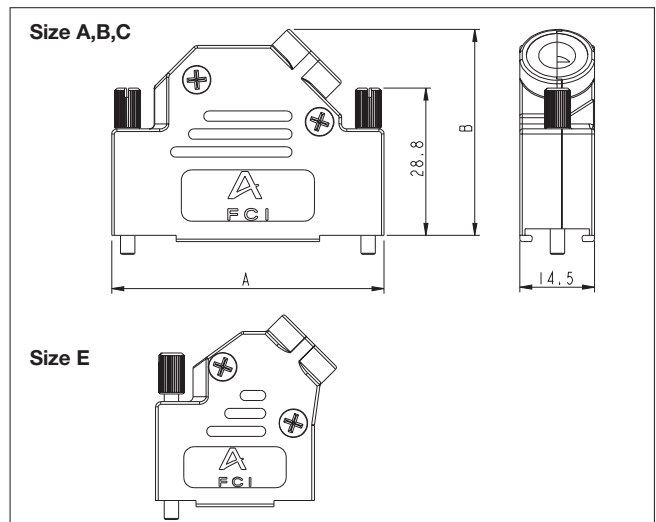

Shell size	Part number	A	B	Cable diameter
E (9)	8655MHRA0901LF	31.0	36.2	4 to 13 mm
A (15)	8655MHRA1501LF	39.5	40.2	
B (25)	8655MHRA2501LF	53.2	40.2	
C (37)	8655MHRA3701LF	69.7	40.2	

Material : zamack, nickel plated
Cable strain relief : steel fibre reinforced polycarbonat UL 94V0 for EMI/RFI screening
Temperature range : -40°C +120°C
Environment : >40 dB between 30 MHz and 1 GHz
Packaging : bulk, in box of 100 pieces
Locking screws : UNC 4-40 thread

D-Sub Accessories

5 • “Snap together” plastic hood

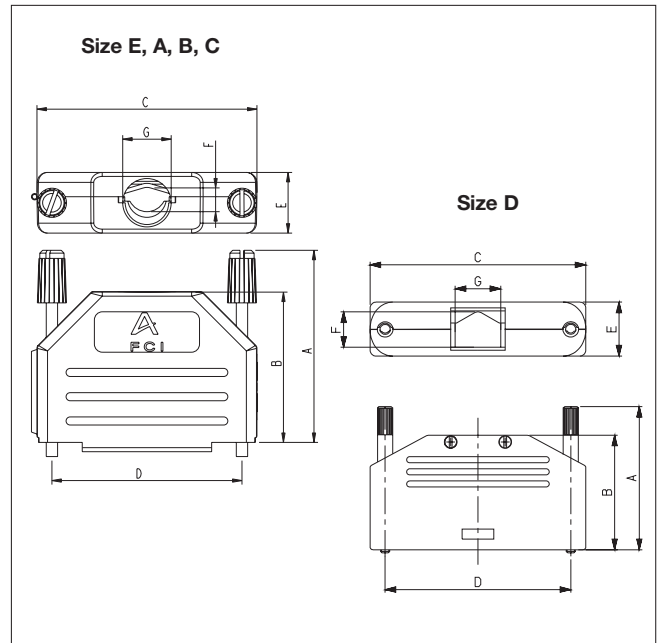

Shell size	Part number	A	B	C	D	E	with clamp		without clamp		
							F min	F max	G	F	G
E(9)	86303637BLF	47.3	31.3	32.4	24.99	15	1	5.5	8.5	7	8.5
A(15)	86303638BLF	47.3	30.8	40.7	33.32	15	4	7	12	11	12
B(25)	86303639BLF	47.3	37.3	54.4	47.04	15	4	7	12	11	12
C(37)	86303640BLF	47.3	36	70.9	63.5	15	4	7	12	11	12
D(50)	86303641BLF	47.3	37.8	71.2	61.11	15	4.4	11.5	15.5	14	18

Material (size E,A,B,C) : nylon (UL 94V2)
 Material (size D) : thermoplastic (UL 94V2)
 Colour : black
 Temperature range : -40°C +95°C
 Packaging : individual sets
 Locking screws : UNC 4-40 thread

6 • Universal plastic hood with metal clamp for strain relief

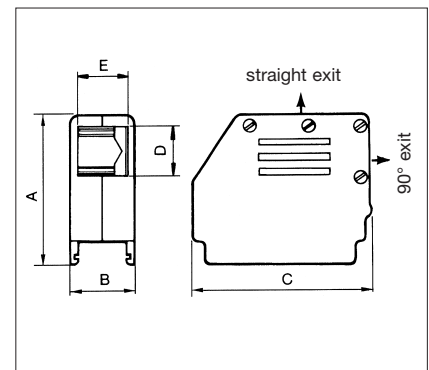

Shell size	Part numbers black hood	Part numbers metalised hood	A	B	C	with clamp		without clamp	
						D	E min. max.	D	E
E	863093C09ALF	863093C09MLF	29.75	15.50	24.25	6	1.90 10.10	8	11.50
A	863093C15ALF	863093C15MLF	29.75	15.50	32.50	6	1.90 10.10	8	11.50
B	863093C25ALF	863093C25MLF	46.50	15.50	46.00	13.50	2.60 10.10	16	11.50
C	863093C37ALF	863093C37MLF	46.50	15.50	60.50	13.50	2.60 10.10	16	11.50
D	863093C50ALF	863093C50MLF	48.50	18.00	56.50	15.50	4.40 12.60	18	14.00

Material (black hood): self extinguishing UL 94V0 thermoplastic
 Material (metalised): thermoplastic
 Temperature range: -55°C +125°C
 Packaging: individual sets

All dimensions in mm

D-Sub Accessories

Monobloc plastic hoods for potting

7 • Straight exit

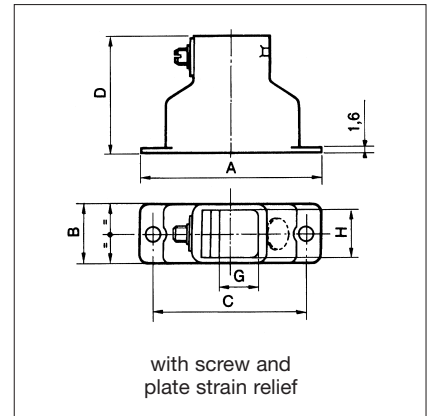
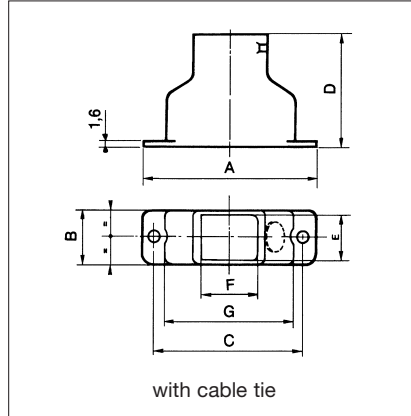

Shell size	Part numbers		A	B	C	D	E	F	G min.	G Max.	H
	Hood with cable tie	Hood with screw and plate									
E	863086BLF	86303920ALF	30.60	12.50	25.00	29.00	9.90	9.90	2.70	7.10	10.50
A	863021BLF	86303921ALF	38.90	12.50	33.32	29.00	9.90	11.90	4.50	9.10	10.50
B	863022BLF	86303922ALF	52.80	12.50	47.05	35.00	9.90	16.40	9.20	13.60	10.50
C	863023BLF	86303923ALF	69.10	12.50	63.50	41.00	9.90	23.40	9.20	20.60	10.50
D	863024BLF	86303924ALF	66.70	15.30	61.10	41.00	12.70	23.40	9.20	20.60	13.30

Material: self extinguishing UL rated 94 V0 thermoplastic

Temperature range: -55°C to +105°C

Colour: black

8 • Right angle exit

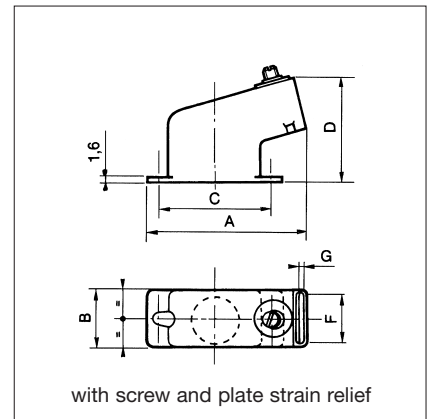
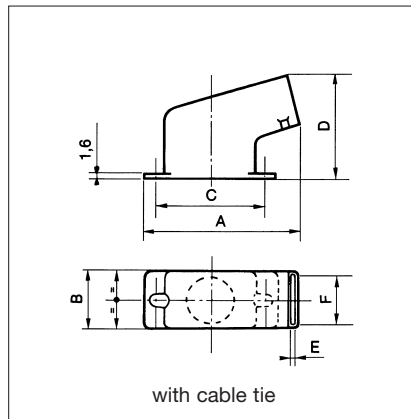

Shell size	Part numbers		A	B	C	D	E	F	G min.	G Max.
	Hood with cable tie	Hood with screw and plate								
E	86305002BLF	86303925ALF	30.60	12.50	25.00	26.20	10.50	10.50	2.70	7.10
A	863026BLF	86303926ALF	38.90	12.50	33.32	28.60	12.50	10.50	4.50	9.10
B	863027BLF	86303927ALF	52.80	12.50	47.05	36.40	17.00	10.50	9.20	13.60
C	863028BLF	86303928ALF	69.10	12.50	63.50	42.60	24.00	10.50	9.20	20.60
D	863029BLF	86303929ALF	66.70	15.30	61.10	41.60	24.00	13.30	9.20	20.60

Material: self extinguishing UL rated 94 V0 thermoplastic

Temperature range: -55°C to +105°C

Colour: black

D-Sub Accessories

Locking devices

9 • Female screw locks

Part numbers	Thread	L Max.	F	Material
863001TLF	M3	8.30	6.90	Brass
86552153TLF	M3	8.30	6.90	Steel
863001017TLF	M3	6.30	5.00	Brass
863001061TLF	M3	13.00	12.00	Brass
863001060TLF	UNC 4.40	8.30	6.90	Brass

Plating:
bright tin

Corrosion resistance:
50 hours exposure to salt spray

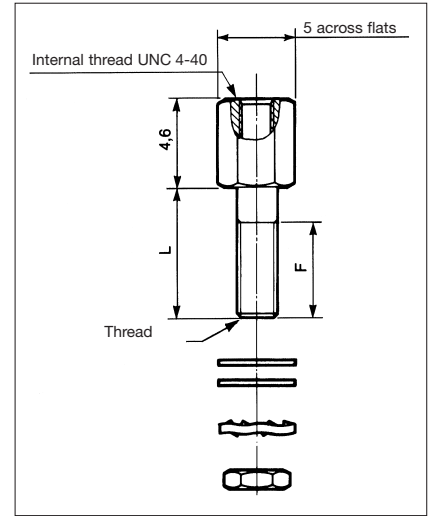

10 • Specific female screw locks for Delta D series

Part numbers	Thread	L Max.	F	Material
863001018TLF	M3	4.5	3.7	Steel
863001019TLF	UNC 4.40	4.5	3.7	Steel

Torque force

Material	Torque Max. (Nm)
Brass	0,5
Steel	0,7

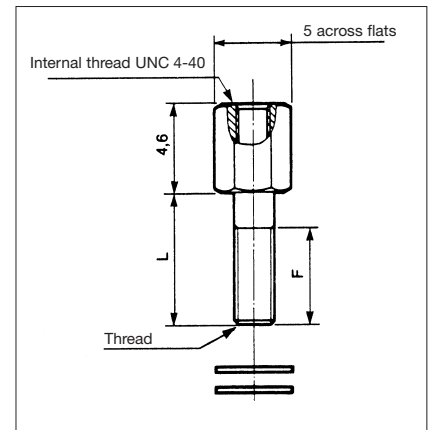

11 • Male screw locks

Shell size	Connector type	For use with connector without hood or with hood 6		For use with connector with hoods 12		For use with connector with hood 7	
		Part numbers	Part numbers	Part numbers	Part numbers		
E	Male	863005ATLF	863004ATLF	863009ATLF			
	Female						
A	Male	863005ATLF	863004ATLF	863009ATLF			
	Female						
B	Male	863008ATLF	863004ATLF	863009ATLF			
	Female						
C	Male	863005ATLF	863004ATLF	863009ATLF			
	Female						
D	Male	863015ATLF	863002ATLF	863025ATLF			
	Female						

Material: steel

Plating: bright tin

Corrosion resistance:
50 hours exposure to salt spray

To obtain military plating (zinc chrom3) exclude «T» in the part number (ex: 863005ALF)

Thread: UNC 4-40



D-Sub Accessories

Hood with cable clamps

12 • Metal hood with circular clamp and straight exit

Material: Steel

Plating: Zinc chrom3

Corrosion resistance:
50 hours exposure to salt spray

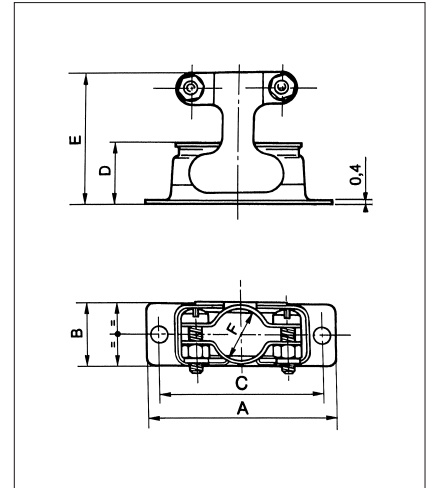

Shell size	Part numbers	A	B	C	D	E	F
E	863010LF	30.55	12.70	24.99	12.30	26.40	8.00
A	863011LF	38.89	12.70	33.32	12.30	26.40	10.00
B	863012LF	52.78	12.70	47.04	12.30	27.20	15.00
C	863013LF	69.06	12.70	63.50	12.30	27.20	18.00
D	863014LF	66.67	15.40	61.17	12.30	27.20	20.60

13 • Metal hood with circular clamp and 30° exit

Material: Steel

Plating: Zinc chrom3

Corrosion resistance:
50 hours exposure to salt spray

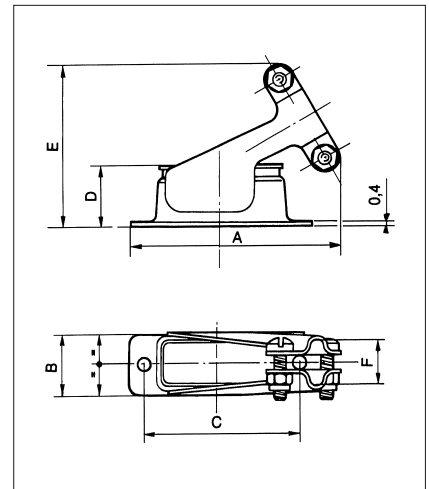

Shell size	Part numbers	A	B	C	D	E	F
E	863016LF	39.00	12.70	24.99	12.30	30.60	8.00
A	863017LF	43.10	12.70	32.32	12.30	32.50	10.00
B	863018LF	55.40	12.70	47.04	12.30	34.50	15.05
C	863019LF	75.30	12.70	63.50	12.30	37.50	18.00
D	863020LF	72.80	15.40	61.11	12.30	37.60	20.60

D-Sub Accessories

14 • Lever locks

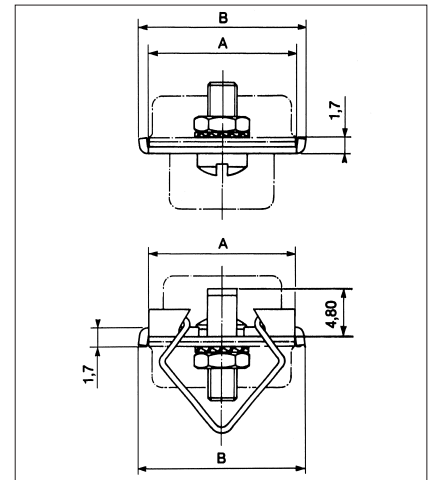
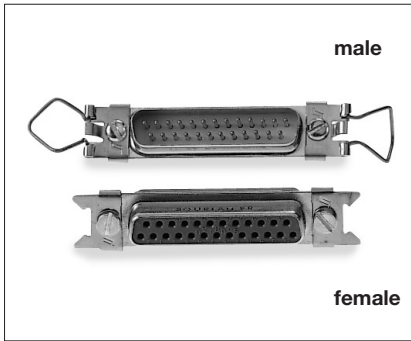

Material: steel

Plating: passivated

Shell size	A	B	M3 thread		UNC 4-40 thread	
			Female	Male	Female	Male
E, A, B, C	12.50	14.30	86303425LF	86552096LF	86303425060LF	86552098LF
D	15.30	17.10	86303426LF	86552097LF	86303426060LF	86552099LF

15 • Specific lever locks for straight Delta D series with harpoons

Shell size	M3 thread		UNC 4-40 thread	
	Female	Male	Female	Male
E, A, B, C	86303425LF	865520961ALF	86303425060LF	865520981ALF
D	86303426LF	865520971ALF	86303426060LF	865520991ALF

D-Sub Accessories

16 • Metal caps

Shell size	For use with connectors	Part numbers	Packaging
E	Male	86553148ATLF	30
	Female	86553113ATLF	30
		86553138ATLF*	30
A	Male	86553149ATLF	25
	Female	86553114ATLF	25
		86553139ATLF*	25
B	Male	86553150ATLF	20
	Female	86553115ATLF	20
		86553140ATLF*	20
C	Male	86553151ATLF	15
	Female	86553116ATLF	15
		86553141ATLF*	15
D	Male	86553152ATLF	10
	Female	86553117ATLF	10
		86553142ATLF*	10



Material: steel

Plating: bright tin

To obtain military plating (zinc chrom3) exclude "T" in part number (ex : 86553148ALF).

* Sealed caps IP 65

17 • Attaching cord for metal caps

86553156LF (length = 100 mm)

Packaging: individual



18 • Plastic dust cap



Shell size	For male connector	A	B	For female connector	A	B
E	70518CLF	19.17	10.30	70523CLF	17.77	9.00
A	70519CLF	27.50	10.30	70524CLF	26.10	9.00
B	70520CLF	41.67	10.70	70525CLF	39.82	9.00
C	70521CLF	58.13	10.70	70526CLF	56.28	9.00
D	70522CLF	55.49	13.40	70527CLF	53.89	11.85

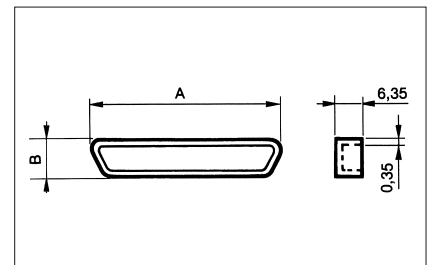

Material: thermoplastic

Color: red

D-Sub Accessories

Brackets

Plastic mounting brackets are normally supplied with angled spill D-Sub connectors series D, DP, DM and DMW.

However, both plastic and metal brackets can be ordered separately, using the part numbers listed below. These brackets are supplied with a screw and a nut. Order two assemblies for each connector.

19 • Plastic brackets

Shell size	Part numbers	A	B	C	D
E, A, B, C	86303714LF	13.20	7.20	10.74	13.90
D	86303715LF	16.00	8.60	12.09	16.50

Material: UL rated 94V0 thermoplastic

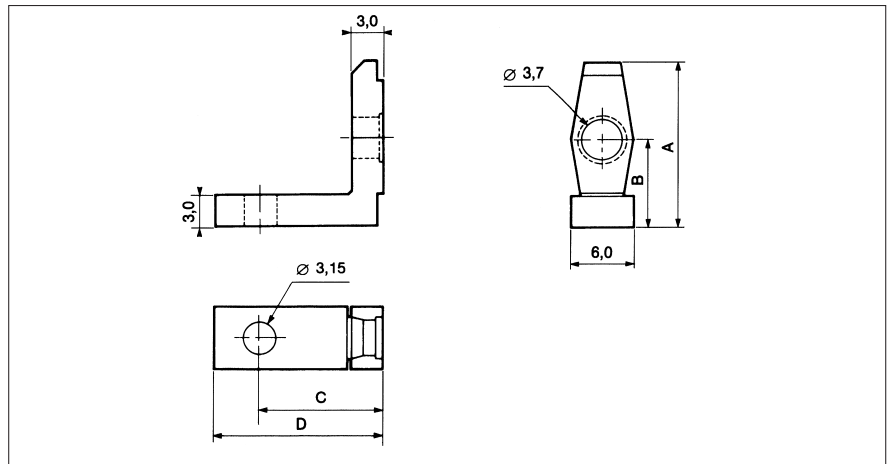

20 • Plastic brackets with oblong mounting hole to PCB

Shell size	Part numbers	A	B	C	D	E
E, A, B, C	86303612LF	13.20	7.40	13.60	10.50	0.8
D	86303613LF	16.15	8.80	16.50	11.60	1.0

Material: UL 94V0 rated thermoplastic

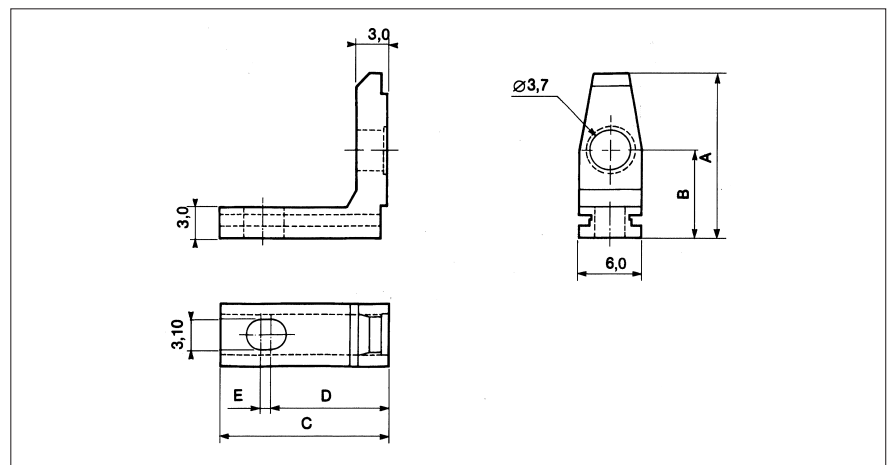

21 • Metal brackets

Shell size	Part numbers	A	B	C	D
E, A, B, C	86552008LF	10.55	7.20	10.74	13.90
D	86552009LF	12.55	8.60	12.09	16.50

Material: steel

Platium: zinc chrom3

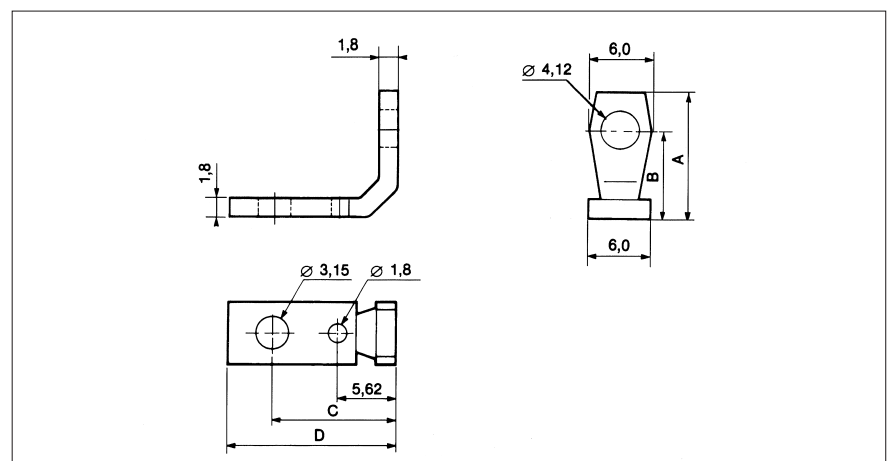

D-Sub Technical Characteristics

Panel cut-out

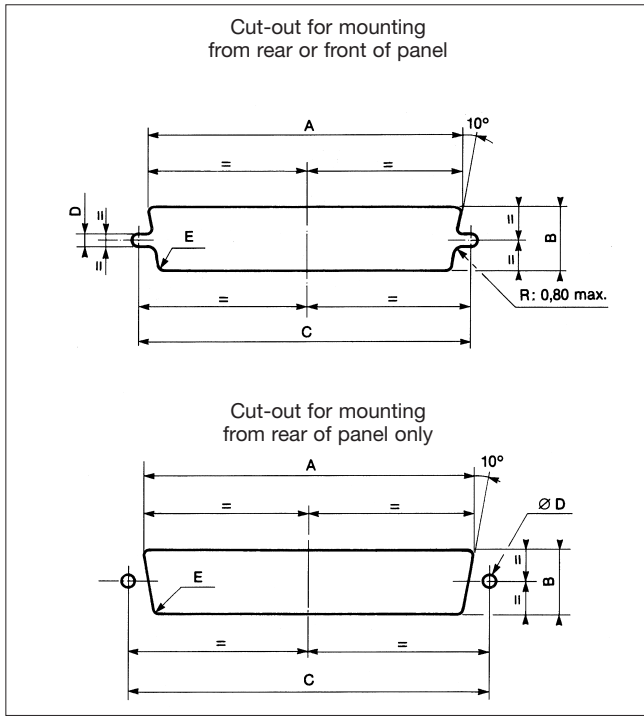

Shell size	Type of mounting	Mounting position	A ^{±0.2}	B ^{±0.2}	C ^{±0.2}	D ^{±0.01}	E ^{±0.1}
E	rigid	front	22.20	13.00	25.00	3.00	2.10
		rear	20.50	11.40	25.00	3.00	3.30
	float	front	23.00	13.80	25.00	2.20	2.10
		rear	21.30	12.20	25.00	2.20	3.30
A	rigid	front	30.50	13.00	33.30	3.00	2.10
		rear	28.80	11.40	33.30	3.00	3.30
	float	front	31.30	13.80	33.30	2.20	2.10
		rear	29.60	12.20	33.30	2.20	3.30
B	rigid	front	44.30	13.00	47.00	3.00	2.10
		rear	42.50	11.40	47.00	3.00	3.30
	float	front	45.10	13.80	47.00	2.20	2.10
		rear	43.30	12.20	47.00	2.20	3.30
C	rigid	front	60.70	13.00	63.50	3.00	2.10
		rear	59.10	11.40	63.50	3.00	3.30
	float	front	61.50	13.80	63.50	2.20	2.10
		rear	59.80	12.20	63.50	2.20	3.30
D	rigid	front	58.30	15.80	61.50	3.00	2.10
		rear	56.30	14.10	61.50	3.00	3.30
	float	front	59.20	16.60	61.50	2.20	2.10
		rear	57.20	14.90	61.50	2.20	3.30

Panel mounting

It is recommended that only **one of a pair** of connectors should be float mounted. Rigid mounted connectors require 2 screws Ø 3mm, float mounting connectors require 2 screws Ø 2 mm.

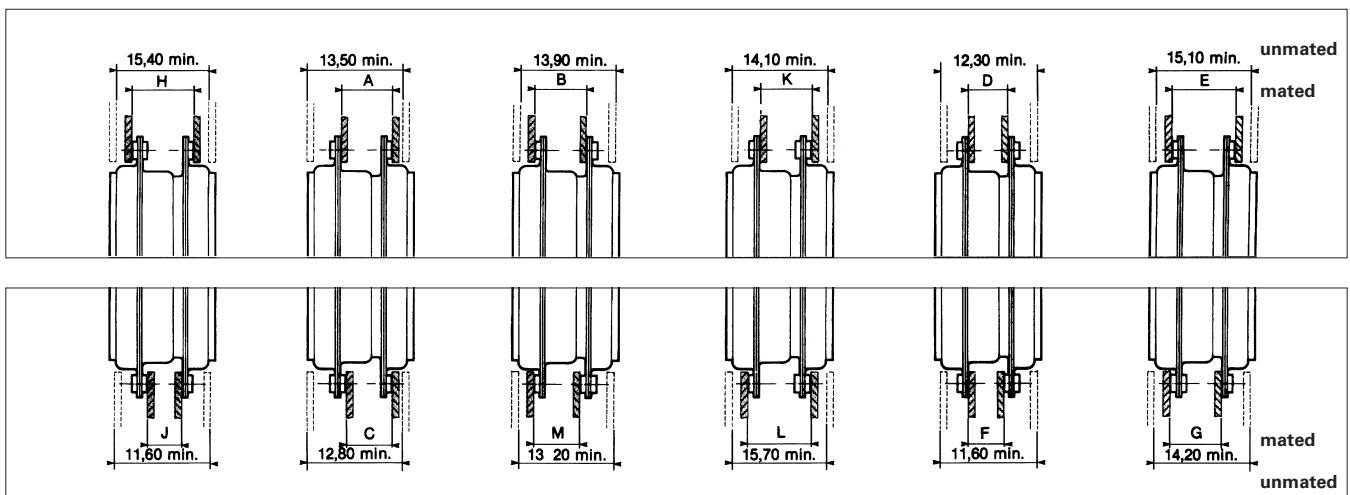

Shell size	A ^{+0.6} ₋₀	B ^{+0.6} ₋₀	C ^{+0.6} ₋₀	D ^{+0.6} ₋₀	E ^{+0.6} ₋₀	F ^{+0.6} ₋₀	G ^{+0.6} ₋₀	H ^{+0.6} ₋₀	J ^{+0.6} ₋₀	K ^{+0.6} ₋₀	L ^{+0.6} ₋₀	M ^{+0.6} ₋₀
E	7.65	7.65	6.85	6.45	8.85	5.65	8.25	9.45	5.65	8.25	9.45	6.85
A	7.65	7.65	6.85	6.45	8.85	5.65	8.25	9.45	5.65	8.25	9.45	6.85
B	7.55	7.55	6.75	6.35	8.85	5.55	8.15	9.35	5.55	8.15	9.35	6.75
C	7.55	7.95	6.75	6.35	9.15	5.55	8.35	9.55	5.55	8.15	9.75	7.15
D	7.55	7.95	6.75	6.35	9.15	5.55	8.35	9.55	5.55	8.15	9.75	7.15

D-Sub Technical Characteristics

Shell dimensions

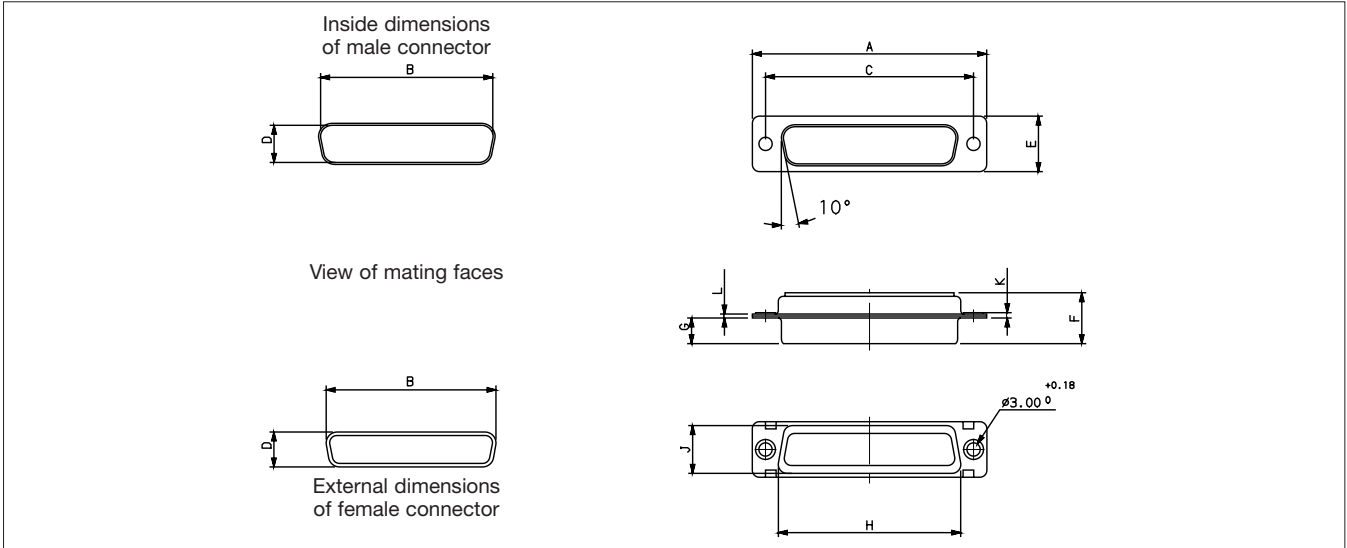

		A± 0.38	B± 0.13	C± 0.13	D± 0.13	E± 0.38	F Max.	G ^{+0.25} ₋₀	H± 0.25	J± 0.25	K Max.	L± 0.12
E	P	30.81	16.91	24.99	8.35	12.55	10.99	5.85	19.27	10.71	1.50	0.90
	S	30.81	16.33	24.99	7.89	12.55	11.21	6.05	19.27	10.71	1.50	0.90
A	P	39.14	25.24	33.32	8.35	12.55	10.99	5.85	27.50	10.71	1.50	0.90
	S	39.14	24.66	33.32	7.89	12.55	11.21	6.05	27.50	10.71	1.50	0.90
B	P	53.03	38.96	47.04	8.35	12.55	11.07	5.75	41.27	10.71	1.50	0.90
	S	53.03	38.37	47.04	7.89	12.55	11.21	6.05	41.27	10.71	1.50	0.90
C	P	69.32	55.42	63.50	8.35	12.55	11.09	5.75	57.70	10.71	1.50	1.00
	S	69.32	54.83	63.50	7.89	12.55	11.21	6.05	57.70	10.71	1.50	0.90
D	P	66.93	52.80	61.11	11.20	15.37	11.09	5.75	55.32	13.56	1.70	1.00
	S	66.93	52.42	61.11	10.74	15.37	11.21	6.05	55.32	13.56	1.50	0.90

PC card drilling dimensions (mm) Note: $\phi A = 0.8$ min. for D, DP
(for solder versions) Note: $\phi A = 0.9$ min. for Delta D, Compact D, HE501, HE507, HE508 and DP US footprint

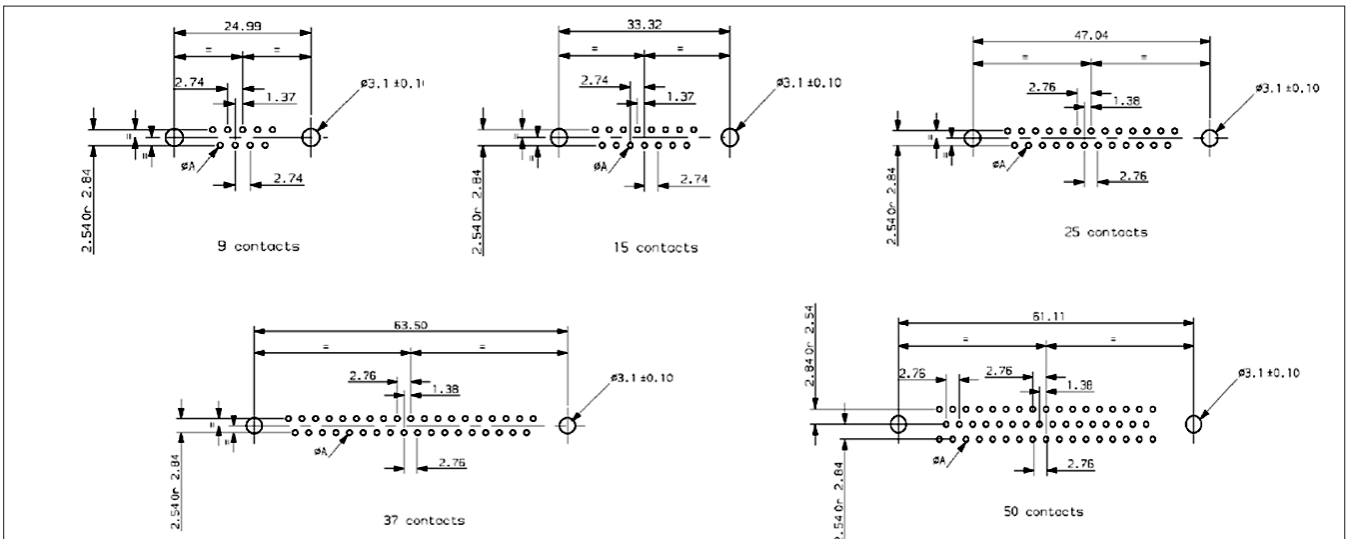

Note: pitch between row= 2.84 for straight spills

D-Sub Technical Characteristics

Layouts

Male insulator front view

Contacts are individually numbered on both sides of the insulator.

Standard connectors

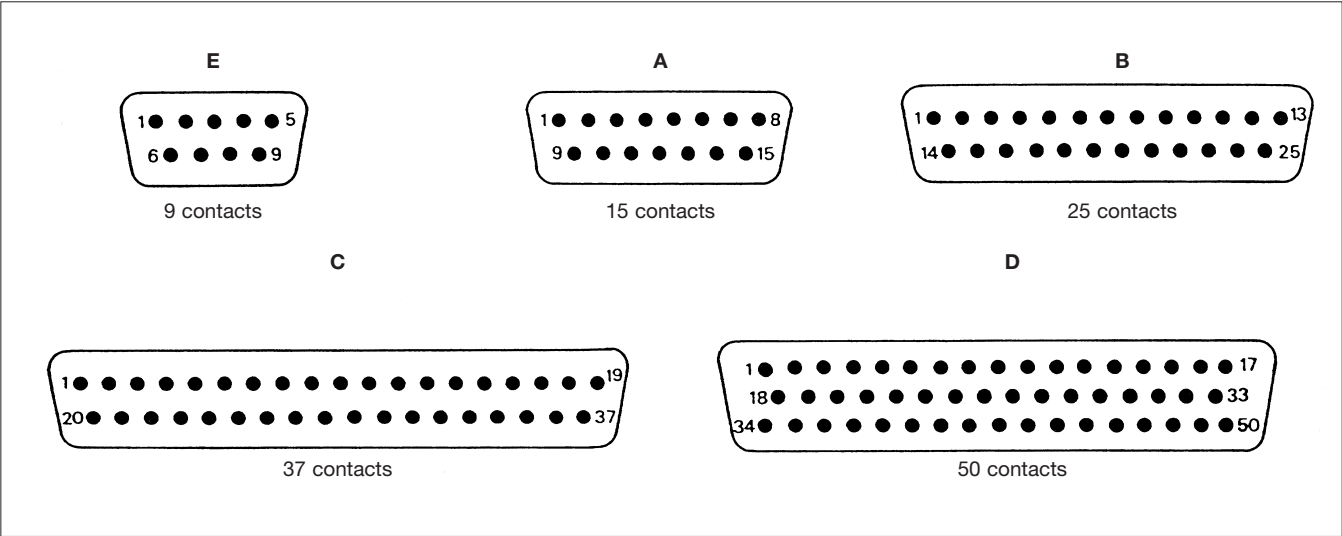



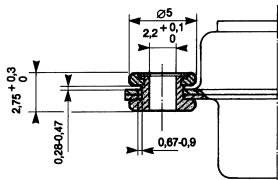
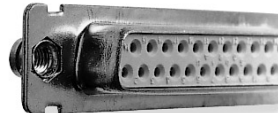
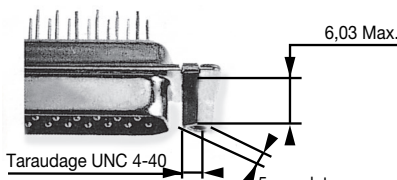
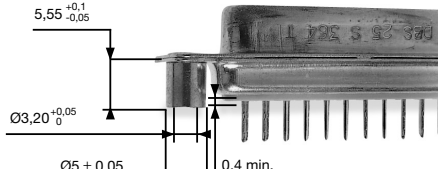

D-Sub Technical Characteristics

Mounting options for D, DP, DW, DM, DMW, 8656, 8657 series (dimensions in mm)

Options 1

<p>F Float mounting (only military series)</p> 	<p>L Clinch nut M3 O Clinch nut UNC 4-40</p> 
<p>V Female screw lock UNC 4-40</p> 	<p>S Spacers riveted to shell</p> 

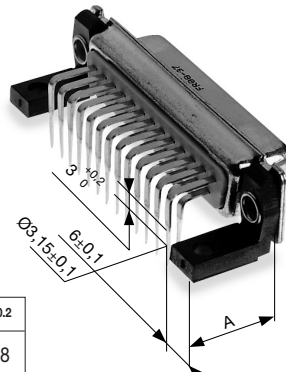
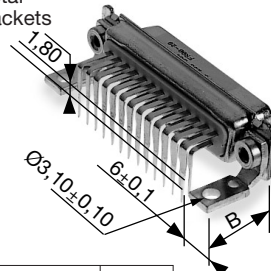
Options 2

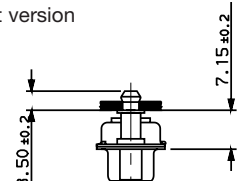
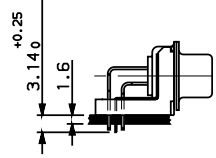
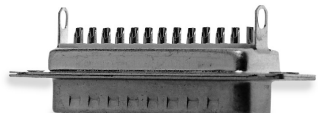
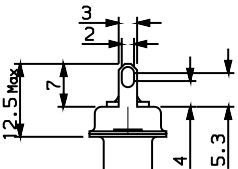
<p>C Without bracket</p> 	<p>Blank For DM and DMW series connectors are delivered with monobloc plastic bracket For DW series</p> <p>P</p>  <table border="1"> <thead> <tr> <th>Termination</th> <th></th> <th>C ± 0.2</th> </tr> </thead> <tbody> <tr> <td rowspan="2">5</td> <td>9 to 37 contacts</td> <td>15.30</td> </tr> <tr> <td>50 contacts</td> <td>17.90</td> </tr> <tr> <td rowspan="2">9 (US standart)</td> <td>9 to 37 contacts</td> <td>13.20</td> </tr> <tr> <td>50 contacts</td> <td>15.70</td> </tr> </tbody> </table> <p>Bracket thickness = 3 ± 0.1</p>	Termination		C ± 0.2	5	9 to 37 contacts	15.30	50 contacts	17.90	9 (US standart)	9 to 37 contacts	13.20	50 contacts	15.70	<p>Blank For DP series connectors are delivered with 2 separate plastic brackets (except for layout 50 with monobloc bracket)</p>  <table border="1"> <thead> <tr> <th>Layout</th> <th>A ± 0.2</th> </tr> </thead> <tbody> <tr> <td>9 to 37 contacts</td> <td>14.8</td> </tr> </tbody> </table>	Layout	A ± 0.2	9 to 37 contacts	14.8
Termination		C ± 0.2																	
5	9 to 37 contacts	15.30																	
	50 contacts	17.90																	
9 (US standart)	9 to 37 contacts	13.20																	
	50 contacts	15.70																	
Layout	A ± 0.2																		
9 to 37 contacts	14.8																		
<p>M Metal brackets</p>  <table border="1"> <thead> <tr> <th>Termination</th> <th></th> <th>B ± 0.2</th> </tr> </thead> <tbody> <tr> <td rowspan="2">5, 8, 14, 18</td> <td>9 to 37 contacts</td> <td>14.80</td> </tr> <tr> <td>50 contacts</td> <td>17.40</td> </tr> <tr> <td rowspan="2">9 (US standart)</td> <td>9 to 37 contacts</td> <td>13.19</td> </tr> <tr> <td>50 contacts</td> <td>15.99</td> </tr> </tbody> </table>	Termination		B ± 0.2	5, 8, 14, 18	9 to 37 contacts	14.80	50 contacts	17.40	9 (US standart)	9 to 37 contacts	13.19	50 contacts	15.99	<p>U Monobloc plastic bracket with metal plate for electrical continuity (dim. same as above)</p> 	<p>G Harpoon with electrical continuity For DM and DP series available in angled version only For PCB thickness of 1.6 Metallized hole $\varnothing 3.1^{+0.12}$</p> <p>straight version</p>  <p>angled version</p>  <p>except 50 way</p>				
Termination		B ± 0.2																	
5, 8, 14, 18	9 to 37 contacts	14.80																	
	50 contacts	17.40																	
9 (US standart)	9 to 37 contacts	13.19																	
	50 contacts	15.99																	
<p>H Shielding fingers for solder D series (not available on 50 way)</p> 																			

D-Sub Technical Characteristics

Mounting options for DELTA D and COMPACT D series

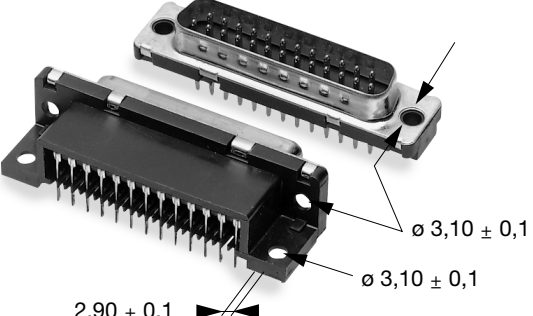
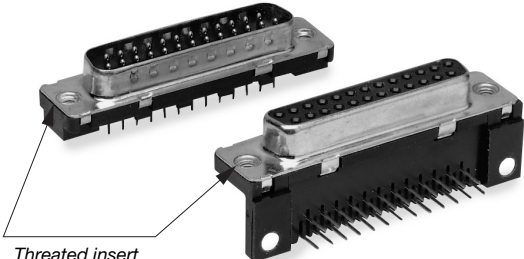
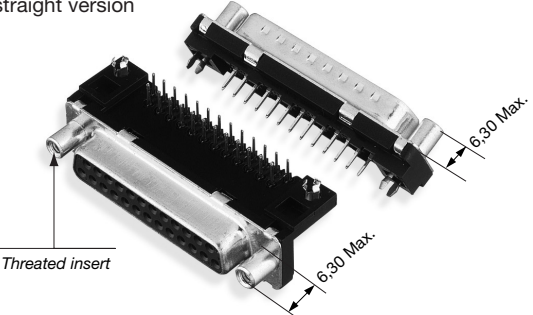
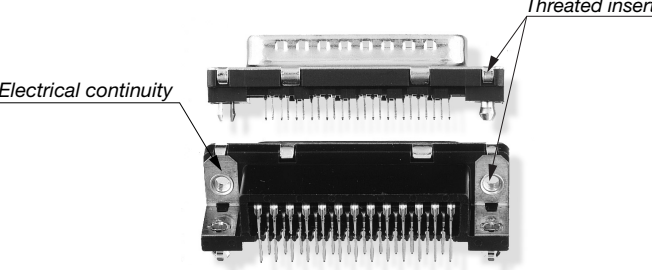
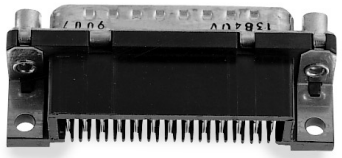
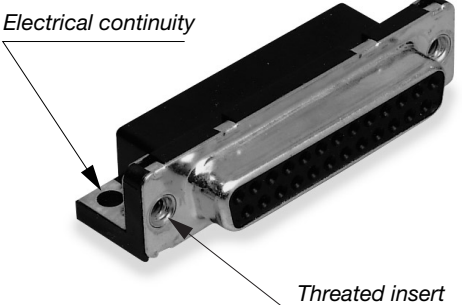
<p>PA Standard hole without hardware</p>  <p>$2,90 \pm 0,1$</p> <p>$\varnothing 3,10 \pm 0,1$</p> <p>$\varnothing 3,10 \pm 0,1$</p>	<p>PL With threaded insert M3 PX With threaded insert UNC 4-40 PV With female screw UNC 4-40 (not represented)</p>  <p>Threaded insert</p>
<p>GV Harpoons + female screw UNC 4-40 + electrical continuity through metal strip for angled version and monobloc hardware for straight version GI Harpoons + female screw M3 + electrical continuity through metal strip for angled version and monobloc hardware for straight version</p>  <p>Threaded insert</p> <p>6,30 Max.</p> <p>6,30 Max.</p>	<p>GL Thread M3 GX Thread UNC 4-40 Harpoons + insert+ electrical continuity through metal strip for angled version and monobloc hardware for straight version</p>  <p>Electrical continuity</p> <p>Threaded insert</p> <p>PCB thickness: 1,6 mm/Metallized toles $\varnothing 3,1^{+0,1}$</p>
<p>UV Female screw UNC 4-40 + electrical continuity through metal strip</p> 	<p>UL Insert M3 + electrical continuity through metal strip UX Insert UNC 4-40 + electrical continuity through metal strip UA Electrical continuity through metal strip</p>  <p>Electrical continuity</p> <p>Threaded insert</p>

FCI reserves the right to make any engineering refinements, alterations or improvements deemed necessary on its products. The dimensions appearing in this catalogue are thus subject to change without notice. When dimensions are critical detailed drawings should be requested.

**For more information on FCI sales offices,
headquarters, agents and local distributors,
visit www.fciconnect.com**



Americas - Tel.: 1 (800) 237 2374

Europe - Tel.: 33 1 39 49 21 83

Asia/Pacific - Tel.: 65 6549 6666

FEDSUB10/06E