

D-Sub

About FCI

Created in 1989, FCI - an Areva Group company - rapidly secured its place among the world's top three manufacturers of connectors and interconnect systems.

With a turnover of 1.56 billion Euros (1.47 billion dollars) in 2002, FCI currently operates in 29 countries where it covers the following markets : communications, data, consumer, automotive and electrical power interconnect.

The company employs about 14 000 staff worldwide.

For more information:
www.fciconnect.com

Introduction

The products are marketed through the international sales organisation of FCI.

FCI D-Sub product lines are present in high technology areas:

- communications,
- data,
- consumer,
- industrial,
- military.

Many styles of termination and performance levels are available and a large choice of accessories completes the range.

Our continuous improvement programme is focused on:

- Manufacturing process control,
- High quality level (ISO 9001 approved),
- Innovation

FCI is an excellent partner for your connection needs.

D-Sub



Index	page
D-Sub overview	
• Selector Guide	4-5
• General Characteristics	6-7
DELTA D	
• Right angle solder DELTA D	8-9
• Straight solder DELTA D	10-11
• Straight press-fit DELTA D	12-13
• Right angle press-fit DELTA D	14-15
Mixed power DW series	
• Mixed power DW series	16-21
• Mixed power DW series - solder	22-23
• Mixed power DW series	24-25
• DW series power solder and crimp	26
• DW series power right angle and straight press-fit	27-28
D / 8656 / 8657 / Compact D / DP series	
• D series	30-31
• 8656 series	32-33
• 8657 series	34-35
• Compact D	36-37
• DP series	38-39
• DM series HE 501	40-41
• DM series HE 508	42-43
Military products	
• DMW series HE 507	44-47
Accessories	
• Accessories	48-57
D-Sub Technical characteristics and dimensions	58-62

Nota : All dimensions in mm

D-Sub Selector Guide

PCB applications

Standard applications

			Pages	
Signal	Right angle	• Solder : Delta D	8	
		• Press-fit : Delta D	14	
		• Solder high density : Compact D		
	Straight	• Solder : Delta D	10	
• Press-fit : Delta D		12		
	D series also available, see catalogue		30	
Power	Right angle	• Solder - Full & mixed power : Delta D	27	
		• Press-fit - Full power : DW series	28	
		• Solder - Full & mixed power : DW series	22	
	Straight	• Press-fit - Full & mixed power	28	

Demanding applications : machined signal contacts

Signal	<ul style="list-style-type: none"> • Right angle solder : DP series • Wire-wrap : DP series • Straight solder : DP series 	38	
--------	--	----	---



Severe environment applications

Signal	HE 501 compliant standard	<ul style="list-style-type: none"> • Right angle : DM series • Straight : DM series 	40	
	HE 508 compliant high temperature	<ul style="list-style-type: none"> • Right angle : DM series • Straight : DM series 	42	
Power	HE 507 compliant	<ul style="list-style-type: none"> • Right angle : DMW series • Straight : DMW series 	44	

D-Sub Selector Guide

Cable applications

■ Standard applications

		Pages	
Signal	• Solder bucket : D series	30	
	• Crimp : 8656 series	32	
	• IDC : 8657 series	34	
Power	• Solder bucket : DW series	26	
	• Crimp : DW series	26	

■ Demanding applications : machined signal contacts

Signal	• Solder bucket : DP series	38	
--------	-----------------------------------	----	---

■ Accessories

Hoods	• Plastic	49	
	• Metallized	50	
	• Metallic	52	
	Others hoods	51	
Locking devices	53	
Other accessories	55	

D-Sub

Technical characteristics

PC BOARD TERMINATION					
SERIES		Delta D Solder for PC Board	Delta D Press-fit	Mixed Power DW	D
ENVIRONMENTAL CHARACTERISTICS	Operating temperature range	-55°C to 125°C	-55°C to 125°C	-55°C to 125°C	-55°C to 125°C
	Salt spray	24 hours	24 hours	24 hours	24 hours
	Damp heat	21 days	21 days	21 days	21 days
	Proof Version	no	no	no	no
NORMES AND APPROVALS	UL 94 VO	E 118235 (R)	E 118235 (R)	E 118235 (R)	E 118235 (R)
	NFC 93425			compliance with HE 507	
	DIN 41652	in compliance with	in compliance with	—	in compliance with
	Others	LNZ 4404		—	
MATERIAL	Shell	Steel	Steel	Steel	Steel
	Insulator	Thermoplastic	Thermoplastic	Thermoplastic	Thermoplastic
	Contacts	Copper alloy	Copper alloy	Copper alloy	Copper alloy
STANDARD PLATING	Shell	Tin	Tin	Tin	Tin
	Contact	active area termination area	Gold over Nickel Tin over Nickel	Gold over Nickel Tin over Nickel	Gold over Nickel Tin over Nickel
ELECTRICAL CHARACTERISTICS	Max current rating per contact	5 A	5 A	7.5 A (signal contact) 40 A (power contact)	5 A
	Dielectric withstanding voltage (DWW)	1000 V.r.m.s.	1000 V.r.m.s.	1000 V.r.m.s.	1000 V.r.m.s.
	Rated voltage V.r.m.s. 50 Hz	300 V.r.m.s.	300 V.r.m.s.	300 V.r.m.s.	300 V.r.m.s.
	Insulation resistance	≥ 5000 MΩ	≥ 5000 MΩ	≥ 5000 MΩ	≥ 5000 MΩ
	Contact resistance	≤ 10 mΩ *	≤ 10 mΩ *	≤ 7.3 mΩ	≤ 10 mΩ *
	Insertion / Extraction force per contact (N)	5N Max. / 0.3N min.	5N Max. / 0.3N min.	5N Max. / 0.3N min.	5N Max. / 0.3N min.
MECHANICAL AND DIMENSIONAL CHARACTERISTICS	Mating / Unmating cycles	200 min.	200 min.	500 min.	200 min.
	Contact diameter on active area	1 mm	1 mm	3.6 mm (power contact) 1 mm (signal contact)	1 mm
	Removable contacts	no	no	yes (cable)	no
	Size			AWG 20 Max. (signal contact) other see page 23	AWG 20 Max.
WIRE	Max diameter on insulator			—	2.1 mm
	LAYOUT	Number of contacts	9, 15, 25, 37, 50* Male and Female	9, 15, 25, 37, 50 Male and Female	9, 15, 25, 37, 50* Male and Female

* Straight version only

D-Sub

PC BOARD TERMINATION					
8656	8657	Compact D High density	DP	DM HE 501 / HE 508	DMW HE 507
-55°C to 105°C	-55°C to 125°C	-55°C to 125°C	-55°C to 125°C	-55°C to 125°C / -55°C to 155°C	-55°C to 125°C
24 hours	24 hours	24 hours	24 hours	48 hours	48 hours
21 days	21 days	21 days	21 days	56 days	56 days
no	no	no	no	no	no
E 118235 (R)	E 118235 (R)	E 118235 (R)	E 118235 (R)	E 118235 (R)	E 118235 (R)
in compliance with	in compliance with		in compliance with	—	—
in compliance with	in compliance with		in compliance with	—	—
				LNZ 4404	
Steel	Steel	Steel	Steel	Steel	Steel
Thermoplastic	Thermoplastic	Thermoplastic	Thermoplastic	Thermoplastic / Thermoset	Thermoplastic / Thermoset
Copper alloy	Copper alloy	Copper alloy	Copper alloy	Copper alloy	Copper alloy
Tin	Tin	Tin	Tin	Cadmium	Cadmium
Gold over Nickel	Gold over Nickel	Gold over Nickel	Gold over Nickel	Gold over Nickel	Gold over Nickel
Tin over Nickel	Tin over Nickel	Tin over Nickel	Tin over Nickel	Tin / Gold over Nickel	Tin / Gold over Nickel
5 A	1.5 A	3 A	7.5 A	7.5 A	7.5 A (signal contact) 40 A (power contact)
1000 V.r.m.s.	1000 V.r.m.s.	1000 V.r.m.s.	1000 V.r.m.s.	1000 V.r.m.s.	1000 V.r.m.s.
300 V.r.m.s.	300 V.r.m.s.	300 V.r.m.s.	300 V.r.m.s.	300 V.r.m.s.	300 V.r.m.s.
≥ 5000 MΩ	≥ 5000 MΩ	≥ 5000 MΩ	≥ 5000 MΩ	≥ 5000 MΩ	≥ 5000 MΩ
≤ 10 mΩ *	≤ 10 mΩ *	≤ 25 mΩ	≤ 7.3 mΩ	≤ 7.3 mΩ	≤ 7.3 mΩ
5N Max. / 0.3N min.	5N Max. / 0.3N min.	5N Max. / 0.3N min.	5N Max. / 0.3N min.	5N Max. / 0.3N min.	5N Max. / 0.3N min.
200 min.	200 min.	200 min.	200 min.	500	500
1 mm	1 mm	0.76 mm	1 mm	1 mm	1 mm (signal contact)
yes	no	no	no	no	yes (coax and power)
AWG 20 Max.	AWG 26 to AWG 30		AWG 20 Max	AWG 20	AWG 20 (signal contact) other see page 46
1.52 mm	Flat cable		2.1 mm	2.1 mm	2.1 mm
9, 15, 25, 37, 50 Male and Female	9, 15, 25, 37 Male and Female	14, 15 Female only	9, 15, 25, 37, 50 Male and Female	9, 15, 25, 37, 50 Male and Female	9, 15, 25, 37, 50 Male and Female

DELTA D Right angle solder



UL Recognized File E 118235 (R)

The DELTA D series has been developed to meet the current requirements of industry (industrial electronics, computers, medical equipment, private exchanges...).

Its development integrates today's demand for ever-increasing rationalization (automation, robots for automatic placement...).

It has been designed and industrialized with the help of the most recent technologies: CAD, 100 % automatic assembly, in-process quality control, etc...

The DELTA D series has angled terminations of different lengths, stamped contacts and is available in the most popular arrangements (9, 15, 25, 37 male/female contacts).

It meets european standards and US Std (HE 5, DIN 41652 and MIL-DTL 24308).

Various options can be selected: threaded inserts, female jack screws, harpoons, grounding device...



Ordering information

Series	D	25	P	13 A	4	GV	00																														
Number of contacts	09, 15, 25, 37																																				
Contacts	P : Pin S : Socket																																				
Termination	<table border="1"> <thead> <tr> <th>Code</th> <th>Type</th> <th>Foot print/Pitch</th> <th>Length of termination</th> <th>PCB thickness</th> </tr> </thead> <tbody> <tr> <td>☺ 13 A</td> <td>Right angled – Europe standard</td> <td>10.4 / 2.54 mm</td> <td>2.90</td> <td>1.6</td> </tr> <tr> <td>13 B</td> <td>Right angled – Europe standard</td> <td>10.4 / 2.54 mm</td> <td>3.70</td> <td>2.4 and 1.6</td> </tr> <tr> <td>23 A</td> <td>Right angled – Europe standard</td> <td>10.4 / 2.84 mm</td> <td>2.90</td> <td>1.6</td> </tr> <tr> <td>23 B</td> <td>Right angled – Europe standard</td> <td>10.4 / 2.84 mm</td> <td>3.70</td> <td>2.4 and 1.6</td> </tr> <tr> <td>☺ 33 E</td> <td>Right angled – US standard</td> <td>8.08 / 2.84 mm</td> <td>3.18</td> <td>1.6</td> </tr> </tbody> </table>							Code	Type	Foot print/Pitch	Length of termination	PCB thickness	☺ 13 A	Right angled – Europe standard	10.4 / 2.54 mm	2.90	1.6	13 B	Right angled – Europe standard	10.4 / 2.54 mm	3.70	2.4 and 1.6	23 A	Right angled – Europe standard	10.4 / 2.84 mm	2.90	1.6	23 B	Right angled – Europe standard	10.4 / 2.84 mm	3.70	2.4 and 1.6	☺ 33 E	Right angled – US standard	8.08 / 2.84 mm	3.18	1.6
Code	Type	Foot print/Pitch	Length of termination	PCB thickness																																	
☺ 13 A	Right angled – Europe standard	10.4 / 2.54 mm	2.90	1.6																																	
13 B	Right angled – Europe standard	10.4 / 2.54 mm	3.70	2.4 and 1.6																																	
23 A	Right angled – Europe standard	10.4 / 2.84 mm	2.90	1.6																																	
23 B	Right angled – Europe standard	10.4 / 2.84 mm	3.70	2.4 and 1.6																																	
☺ 33 E	Right angled – US standard	8.08 / 2.84 mm	3.18	1.6																																	
Plating	4 : Standard class (≥ 200 mating / unmating) 6 : High performance class (≥ 500 mating / unmating) - LNZ 4404																																				
Mounting options (see cover page 62)	<table border="1"> <thead> <tr> <th>Options</th> <th></th> </tr> </thead> <tbody> <tr> <td>PA</td> <td>Standard hole</td> </tr> <tr> <td>PL</td> <td>Threaded insert M3</td> </tr> <tr> <td>PX</td> <td>Threaded insert UNC 4-40</td> </tr> <tr> <td>PV</td> <td>Female screw UNC 4-40</td> </tr> <tr> <td>GI</td> <td>Harpoons + Female screw M3 + elec. continuity</td> </tr> <tr> <td>GL</td> <td>Harpoons + insert M3 + elec. continuity</td> </tr> <tr> <td>☺ GX</td> <td>Harpoons + insert UNC 4-40 + elec. continuity</td> </tr> <tr> <td>☺ GV</td> <td>Harpoons + female screw UNC 4-40 + elec. continuity</td> </tr> <tr> <td>UA</td> <td>Elec. continuity</td> </tr> <tr> <td>UL</td> <td>Insert M3 + elec. continuity</td> </tr> <tr> <td>UX</td> <td>Insert UNC 4-40 + elec. continuity</td> </tr> <tr> <td>UV</td> <td>Female screw UNC 4-40 + elec. continuity</td> </tr> </tbody> </table>							Options		PA	Standard hole	PL	Threaded insert M3	PX	Threaded insert UNC 4-40	PV	Female screw UNC 4-40	GI	Harpoons + Female screw M3 + elec. continuity	GL	Harpoons + insert M3 + elec. continuity	☺ GX	Harpoons + insert UNC 4-40 + elec. continuity	☺ GV	Harpoons + female screw UNC 4-40 + elec. continuity	UA	Elec. continuity	UL	Insert M3 + elec. continuity	UX	Insert UNC 4-40 + elec. continuity	UV	Female screw UNC 4-40 + elec. continuity				
Options																																					
PA	Standard hole																																				
PL	Threaded insert M3																																				
PX	Threaded insert UNC 4-40																																				
PV	Female screw UNC 4-40																																				
GI	Harpoons + Female screw M3 + elec. continuity																																				
GL	Harpoons + insert M3 + elec. continuity																																				
☺ GX	Harpoons + insert UNC 4-40 + elec. continuity																																				
☺ GV	Harpoons + female screw UNC 4-40 + elec. continuity																																				
UA	Elec. continuity																																				
UL	Insert M3 + elec. continuity																																				
UX	Insert UNC 4-40 + elec. continuity																																				
UV	Female screw UNC 4-40 + elec. continuity																																				
Options	00 : Standard series																																				

DELTA D

Right angle solder

Specific dimensions

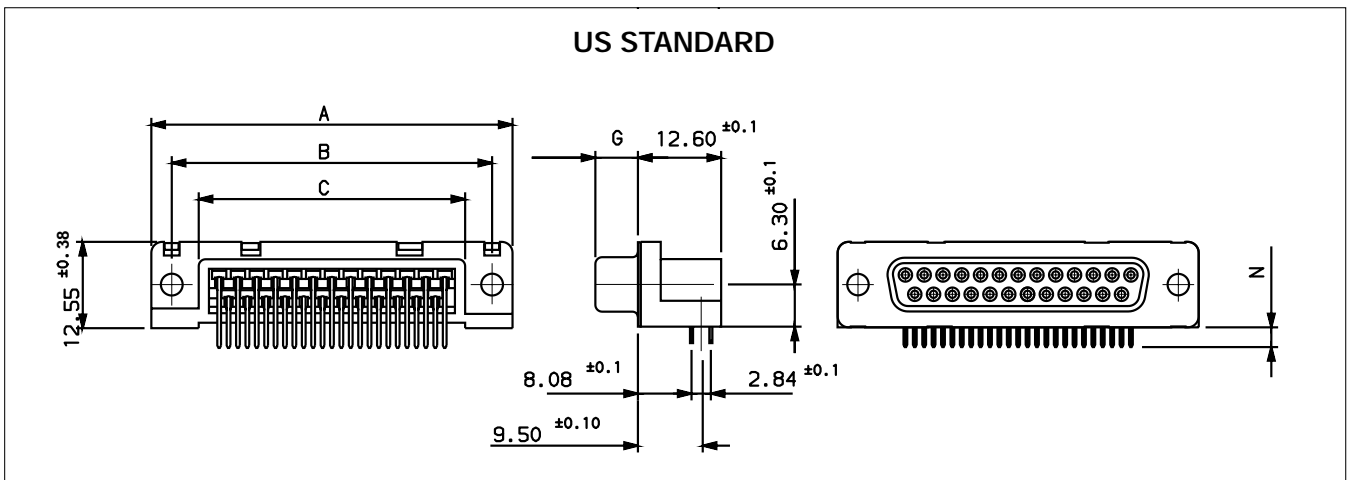
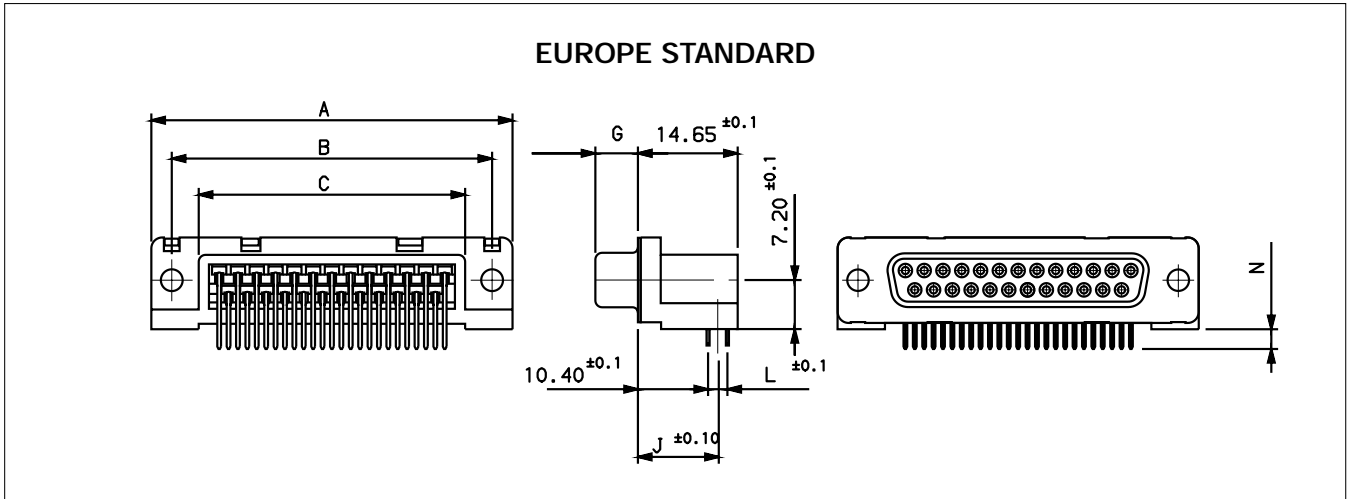







		A ± 0.38	B ± 0.12	C ± 0.10	G $^{+0.25}_{-0}$	J ± 0.10		L ± 0.1		N ± 0.30		
						Termination		Termination		Terminal Length		
						13.	23.	13.	23.	13 A 23 A	13 B 23 B	33 E
9	P	30.81	24.99	16.96	5.90 $^{+0.15}_{-0}$	11.67	11.82	2.54	2.84	2.90	3.70	3.18
	S	30.81	24.99	16.96	6.05	11.67	11.82	2.54	2.84	2.90	3.70	3.18
15	P	39.14	33.32	25.18	5.90 $^{+0.15}_{-0}$	11.67	11.82	2.54	2.84	2.90	3.70	3.18
	S	39.14	33.32	25.18	6.05	11.67	11.82	2.54	2.84	2.90	3.70	3.18
25	P	53.03	47.04	39.12	5.70	11.67	11.82	2.54	2.84	2.90	3.70	3.18
	S	53.03	47.04	39.12	6.05	11.67	11.82	2.54	2.84	2.90	3.70	3.18
37	P	69.32	63.50	55.68	5.70	11.67	11.82	2.54	2.84	2.90	3.70	3.18
	S	69.32	63.50	55.68	6.05	11.67	11.82	2.54	2.84	2.90	3.70	3.18

DELTA D Straight solder

 UL Recognized File E 118235 (R)



Ordering information

Series	D	25	P	24 A	4	GV	00																									
Number of contacts	09, 15, 25, 37, 50																															
Contacts	P : Pin S : Socket																															
Terminations	<table border="1"> <thead> <tr> <th>Code</th> <th>Type</th> <th>Foot print/Pitch</th> <th>Length of termination</th> <th>PCB thickness</th> </tr> </thead> <tbody> <tr> <td>14 A</td> <td>Straight version (low profile)</td> <td>5.6 / 2.84 mm</td> <td>2.90</td> <td>1.6</td> </tr> <tr> <td> 24 A</td> <td>Straight version</td> <td>6 / 2.84 mm</td> <td>2.90</td> <td>1.6</td> </tr> <tr> <td>24 B</td> <td>Straight version</td> <td>6 / 2.84 mm</td> <td>3.70</td> <td>2.4</td> </tr> <tr> <td>34 A</td> <td>Straight version</td> <td>6.9 / 2.84 mm</td> <td>2.90</td> <td>1.6</td> </tr> </tbody> </table>							Code	Type	Foot print/Pitch	Length of termination	PCB thickness	14 A	Straight version (low profile)	5.6 / 2.84 mm	2.90	1.6	 24 A	Straight version	6 / 2.84 mm	2.90	1.6	24 B	Straight version	6 / 2.84 mm	3.70	2.4	34 A	Straight version	6.9 / 2.84 mm	2.90	1.6
Code	Type	Foot print/Pitch	Length of termination	PCB thickness																												
14 A	Straight version (low profile)	5.6 / 2.84 mm	2.90	1.6																												
 24 A	Straight version	6 / 2.84 mm	2.90	1.6																												
24 B	Straight version	6 / 2.84 mm	3.70	2.4																												
34 A	Straight version	6.9 / 2.84 mm	2.90	1.6																												
Plating	4 : Standard class (≥ 200 mating / unmating) 6 : High performance class (≥ 500 mating / unmating) - LNZ 4404 -																															
Mounting options (see cover page 62)	<table border="1"> <thead> <tr> <th>Options</th> <th></th> </tr> </thead> <tbody> <tr> <td>PA</td> <td>Standard hole</td> </tr> <tr> <td>PL</td> <td>Threaded insert M3</td> </tr> <tr> <td>PX</td> <td>Threaded insert UNC 4-40</td> </tr> <tr> <td>PV</td> <td>Female screw UNC 4-40</td> </tr> <tr> <td>GL</td> <td>Harpoons + insert M3 + elec. continuity</td> </tr> <tr> <td>GX</td> <td>Harpoons + insert UNC 4-40 + elec. continuity</td> </tr> <tr> <td> GV</td> <td>Harpoons + Female screw UNC 4-40 + elec. continuity</td> </tr> </tbody> </table>							Options		PA	Standard hole	PL	Threaded insert M3	PX	Threaded insert UNC 4-40	PV	Female screw UNC 4-40	GL	Harpoons + insert M3 + elec. continuity	GX	Harpoons + insert UNC 4-40 + elec. continuity	 GV	Harpoons + Female screw UNC 4-40 + elec. continuity									
Options																																
PA	Standard hole																															
PL	Threaded insert M3																															
PX	Threaded insert UNC 4-40																															
PV	Female screw UNC 4-40																															
GL	Harpoons + insert M3 + elec. continuity																															
GX	Harpoons + insert UNC 4-40 + elec. continuity																															
 GV	Harpoons + Female screw UNC 4-40 + elec. continuity																															
Other options	00 : Standard series																															

DELTA D Straight solder

Specific dimensions

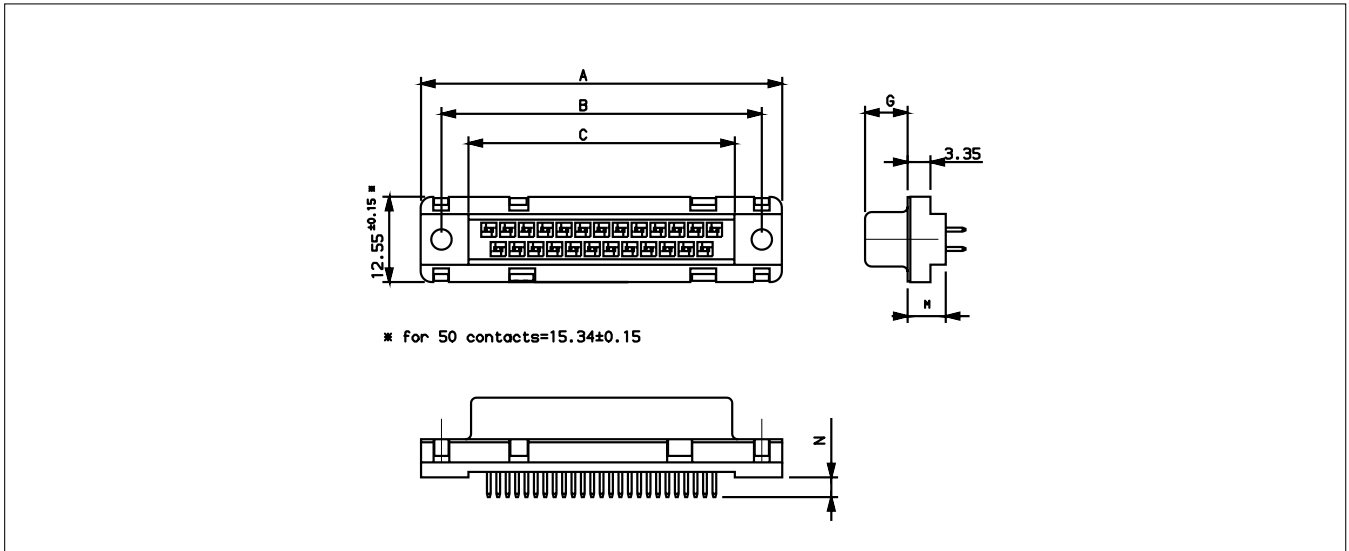

		A±0.38	B±0.12	C±0.10	G $^{+0.25}_{0}$	M±0.10			N±0.30	
						Termination			Terminal Length	
						14.	24.	34.	14 A 24 A 34 A	24 B
9	P	30.81	24.99	16.96	5.90 $^{+0.15}_{-0}$	5.60	6.00	6.90	2.90	3.70
	S	30.81	24.99	16.96	6.05	5.60	6.00	6.90	2.90	3.70
15	P	39.14	33.32	25.18	5.90 $^{+0.15}_{-0}$	5.60	6.00	6.90	2.90	3.70
	S	39.14	33.32	25.18	6.05	5.60	6.00	6.90	2.90	3.70
25	P	53.03	47.04	39.12	5.70	5.60	6.00	6.90	2.90	3.70
	S	53.03	47.04	39.12	6.05	5.60	6.00	6.90	2.90	3.70
37	P	69.32	63.50	55.68	5.70	5.60	6.00	6.90	2.90	3.70
	S	69.32	63.50	55.68	6.05	5.60	6.00	6.90	2.90	3.70
50	P	67.10	61.11	54.11	5.70	5.60	6.00	6.90	2.90	3.70
	S	67.10	61.11	54.11	6.05	5.60	6.00	6.90	2.90	3.70

DELTA D Straight press-fit

Press-fit termination



In case of SMT (Surface Mount Technology) manufacturing process this new press-fit Delta D allows to save cost of an additional wave soldering. The "eye of the needle" termination combined with a special flat rock design (easy application by pressure on insulator) make this product line very attractive.



Ordering information

Series	D	25	P	91 C	4	PA	00																
Number of contacts	09, 15, 25, 37, 50																						
Contacts	P : Pin S : Socket																						
Termination type	☺ 91 C : Press-fit for all 3 PCB thickness : (1.6 mm ; 2.4 mm ; 3.2 mm and more) - Europe standard 90 C : Press-fit for all 3 PCB thickness : (1.6 mm ; 2.4 mm ; 3.2 mm and more) - Low profile																						
Plating	4 : Standard class (≥ 200 mating / unmating) 6 : High performance class (≥ 500 mating / unmating)																						
Mounting options (see cover page 62)	<table border="1"> <thead> <tr> <th>Options</th> <th></th> </tr> </thead> <tbody> <tr> <td>PA</td> <td>Standard hole</td> </tr> <tr> <td>PL</td> <td>Threaded insert M3</td> </tr> <tr> <td>☺ PX</td> <td>Threaded insert UNC 4-40</td> </tr> <tr> <td>☺ PV</td> <td>Female screw UNC 4-40</td> </tr> <tr> <td>GL</td> <td>Harpoons + insert M3 + elec. continuity</td> </tr> <tr> <td>GX</td> <td>Harpoons + insert UNC 4-40 + elec. continuity</td> </tr> <tr> <td>GV</td> <td>Harpoons + Female screw UNC 4-40 + elec. continuity</td> </tr> </tbody> </table>							Options		PA	Standard hole	PL	Threaded insert M3	☺ PX	Threaded insert UNC 4-40	☺ PV	Female screw UNC 4-40	GL	Harpoons + insert M3 + elec. continuity	GX	Harpoons + insert UNC 4-40 + elec. continuity	GV	Harpoons + Female screw UNC 4-40 + elec. continuity
Options																							
PA	Standard hole																						
PL	Threaded insert M3																						
☺ PX	Threaded insert UNC 4-40																						
☺ PV	Female screw UNC 4-40																						
GL	Harpoons + insert M3 + elec. continuity																						
GX	Harpoons + insert UNC 4-40 + elec. continuity																						
GV	Harpoons + Female screw UNC 4-40 + elec. continuity																						
Other options	00 : Standard																						

Technical characteristics – page 6

☺ Preferred option

DELTA D

Straight press-fit

Specific dimensions

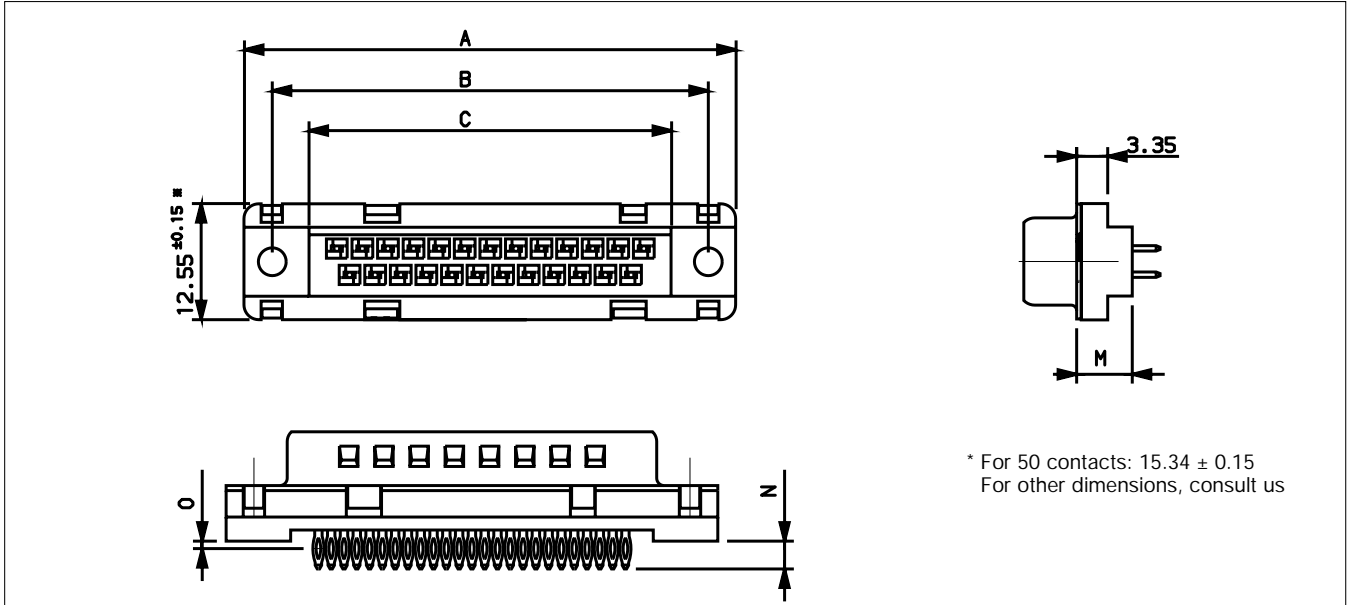

* For 50 contacts: 15.34 ± 0.15
For other dimensions, consult us

Size	A±0.38	B± 0.12	C± 0.10
09	30.81	24.99	16.96
15	39.14	33.32	25.18
25	53.03	47.04	39.12
37	69.32	63.50	55.68
50	66.93	61.11	53.11

Termination type	M±0.1	N±0.3	O±0.2
90 C	5.60	3.40	1.20
91 C	6.00	3.00	0.80

Press-fit features

Application by pressure on insulator • D-Sub insertion kit : 8646 3064 01
Eye of the needle design.

• Metallized hole dimensions

P.C.B. hole definition (note 1 and 2)		Press-fit contacts	Press-fit harpoons
		Drill diameter	Ø 1.15 ref (note 3)
	Drilled hole	Ø 1.2 - 1.18	Ø 3.19 - 3.25
	Copper plating	25 µ min (recommended 50 µ max)	25 µ min (recommended 50 µ max)
	Tin-lead plating	15 µ max (recommended 5 µ min)	15 µ max (recommended 5 µ min)
	Finish hole (after reflow)	Ø 0.94 - 1.09	Ø 3.02 - 3.20

Note 1 : These dimensions must be respected to ensure press-fit pin performance

Note 2 : According to IEC-352-S specification

Note 3 : Vital requirement for press-fit pin performance

• Press-fit performance

	Press-fit contacts	Press-fit harpoons
Insertion force	≤ 100 N	≤ 120 N
Extraction force	≥ 30 N	≥ 30 N

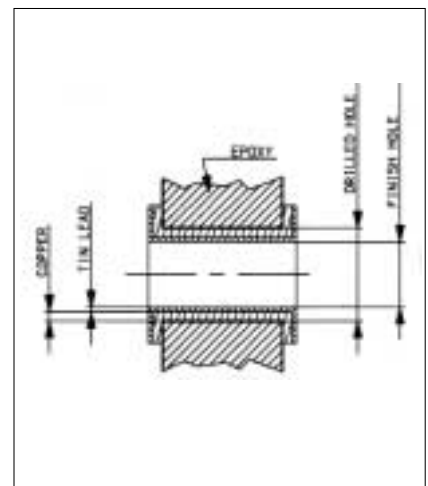









DELTA D

Right angle press-fit

 UL Recognized File E 118235 (R)



Ordering information

Series	D	25	P	82 C	4	PA	00																
Number of contacts	09, 15, 25, 37, 50 (only for eurostyle version)																						
Contacts	P : Pin S : Socket																						
Termination type	<table border="1"> <thead> <tr> <th>Code</th> <th>Type</th> <th colspan="2">Foot print / Pitch</th> </tr> </thead> <tbody> <tr> <td> 82 C</td> <td>Eurostyle</td> <td>9.4 / 2.54 10.3 / 2.54</td> <td>9 to 37 way 50 way</td> </tr> <tr> <td>80 C</td> <td>US standard</td> <td>8.08 / 2.84</td> <td>9 to 37 way</td> </tr> <tr> <td>81 C</td> <td>Europe standard*</td> <td>10.4 / 2.54</td> <td>9 to 37 way</td> </tr> </tbody> </table>							Code	Type	Foot print / Pitch		 82 C	Eurostyle	9.4 / 2.54 10.3 / 2.54	9 to 37 way 50 way	80 C	US standard	8.08 / 2.84	9 to 37 way	81 C	Europe standard*	10.4 / 2.54	9 to 37 way
Code	Type	Foot print / Pitch																					
 82 C	Eurostyle	9.4 / 2.54 10.3 / 2.54	9 to 37 way 50 way																				
80 C	US standard	8.08 / 2.84	9 to 37 way																				
81 C	Europe standard*	10.4 / 2.54	9 to 37 way																				
Plating	4 : Standard class (≥ 200 mating / unmating) 6 : High performance class (≥ 500 mating / unmating)																						
Mounting options (see cover page 62)	<table border="1"> <thead> <tr> <th>Options</th> <th></th> </tr> </thead> <tbody> <tr> <td>PA</td> <td>Standard hole</td> </tr> <tr> <td>PL</td> <td>Threaded insert M3</td> </tr> <tr> <td>PX</td> <td>Threaded insert UNC 4-40</td> </tr> <tr> <td>PV</td> <td>Female screw UNC 4-40</td> </tr> <tr> <td>GL</td> <td>Harpoons + insert M3</td> </tr> <tr> <td> GX</td> <td>Harpoons + insert UNC 4-40</td> </tr> <tr> <td> GV</td> <td>Harpoons + Female screw UNC 4-40</td> </tr> </tbody> </table>							Options		PA	Standard hole	PL	Threaded insert M3	PX	Threaded insert UNC 4-40	PV	Female screw UNC 4-40	GL	Harpoons + insert M3	 GX	Harpoons + insert UNC 4-40	 GV	Harpoons + Female screw UNC 4-40
Options																							
PA	Standard hole																						
PL	Threaded insert M3																						
PX	Threaded insert UNC 4-40																						
PV	Female screw UNC 4-40																						
GL	Harpoons + insert M3																						
 GX	Harpoons + insert UNC 4-40																						
 GV	Harpoons + Female screw UNC 4-40																						
Other options	00 : Standard																						

DELTA D

Right angle press-fit

Specific dimensions

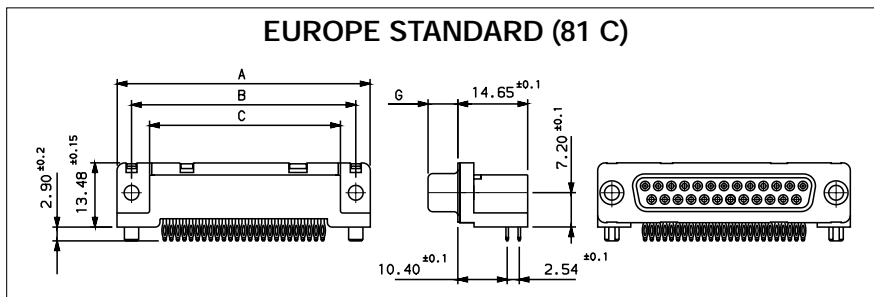
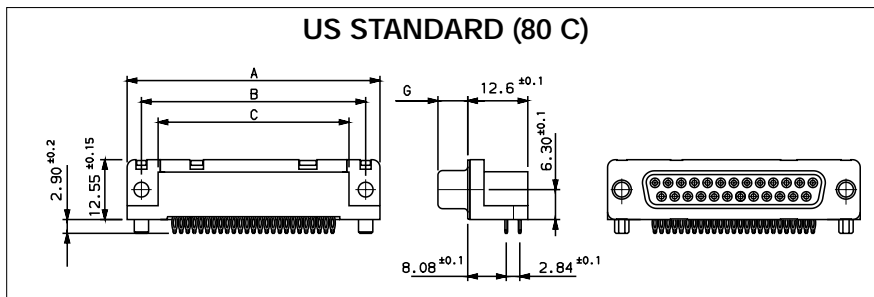
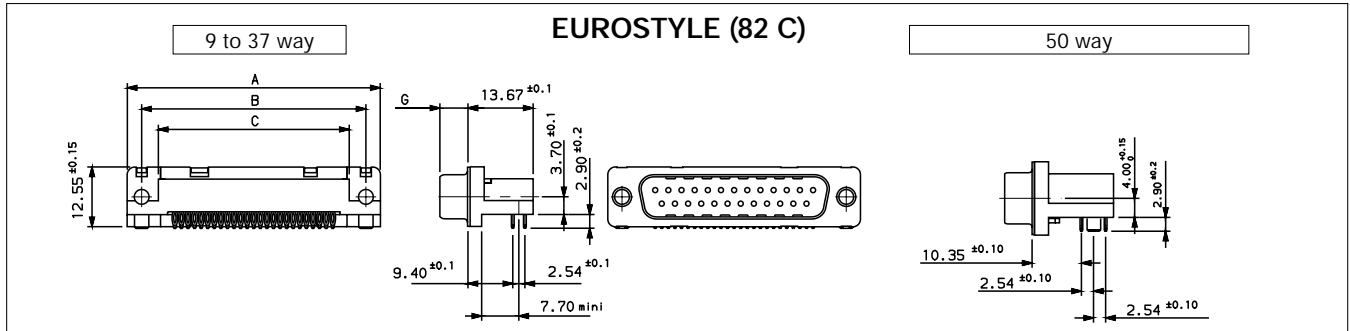

	A±0.38	B±0.12	C±0.10	G ^{+0.25} ₋₀	
9	P	30.81	24.99	18.00	5.90 ^{-0.15}
	S	30.81	24.99	18.00	6.05
15	P	39.14	33.32	26.32	5.90 ^{-0.15}
	S	39.14	33.32	26.32	6.05
25	P	53.03	47.04	40.04	5.70
	S	53.03	47.04	40.04	6.05
37	P	69.32	63.50	55.50	5.70
	S	69.32	63.50	55.50	6.05
50*	P	67.10	61.11	54.10	5.70
	S	67.10	61.11	54.10	6.05

* Only for Eurostyle version.

Press-fit features

Application by pressure on insulator • D-Sub insertion kit : 8646 3064 01
Eye of the needle design.

• Metallized hole dimensions

		Press-fit contacts	Press-fit harpoons
P.C.B. hole definition (note 1 and 2)	Drill diameter	Ø 1.15 ref (note 3)	Ø 3.22 ref (note 3)
	Drilled hole	Ø 1.2 - 1.18	Ø 3.19 - 3.25
	Copper plating	25 µ min (recommended 50 µ max)	25 µ min (recommended 50 µ max)
	Tin-lead plating	15 µ max (recommended 5 µ min)	15 µ max (recommended 5 µ min)
	Finish hole (after reflow)	Ø 0.94 - 1.09	Ø 3.02 - 3.20

Note 1 : These dimensions must be respected to ensure press-fit pin performance

Note 2 : According to IEC-352-S specification

Note 3 : Vital requirement for press-fit pin performance

• Press-fit performance

	Press-fit contacts	Press-fit harpoons
Insertion force	≤ 100 N	≤ 120 N
Extraction force	≥ 30 N	≥ 30 N

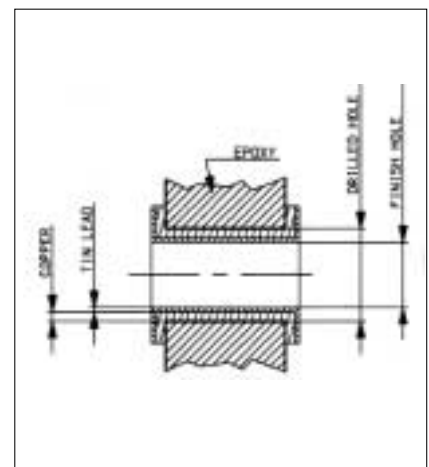

Mixed power DW series

Solder termination



Press-fit termination



Mixed power DW series

This mixed power version has been specially developed for industrial and telecom applications.

This range covers all mixed layouts, straight and angled Board connectors, crimp and solder cable connectors from 10 to 40A. All versions are delivered with tin plated terminations.

PC board connectors

Angled and straight versions

Solder and press-fit terminations



PC board connectors are delivered with preloaded power contacts, and proposed with all standard mounting options (bracket, inserts, harpoons...).

Delta D design can be provided upon request.

Cable connectors









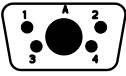
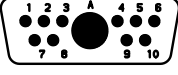

Cable crimp and solder power contacts are delivered with colour code plastic clips for an easy wire gauge identification.

Mixed power DW series

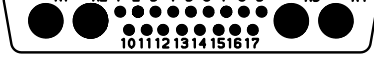
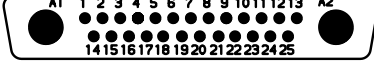
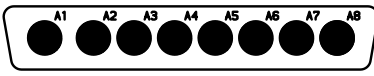
Layouts

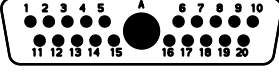
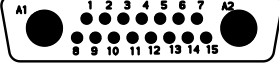
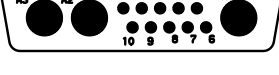
Male insulator front view

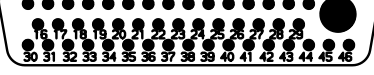
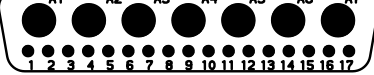
Shell size	Layout	
E	2V2	
	5W1	
A	11W1	
	7W2	
	3W3	
	3V3	
C	25W3	
	21WA4	
	27W2	
	8W8	

Shell size	Layout	
B	21W1	
	17W2	
	13W3	
	9W4	
	5W5	
D	47W1	
	24W7	
	36W4	

Mixed power DW series

Derating curve

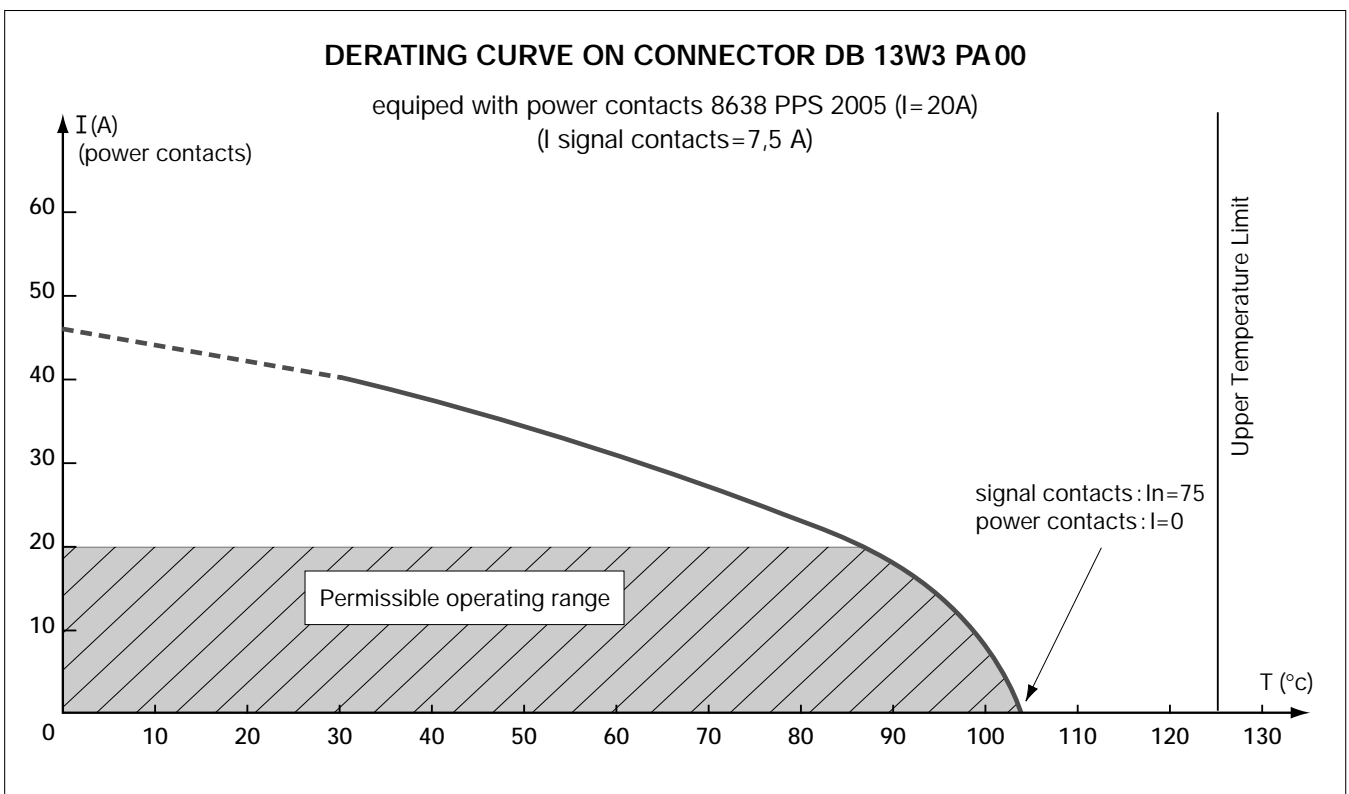
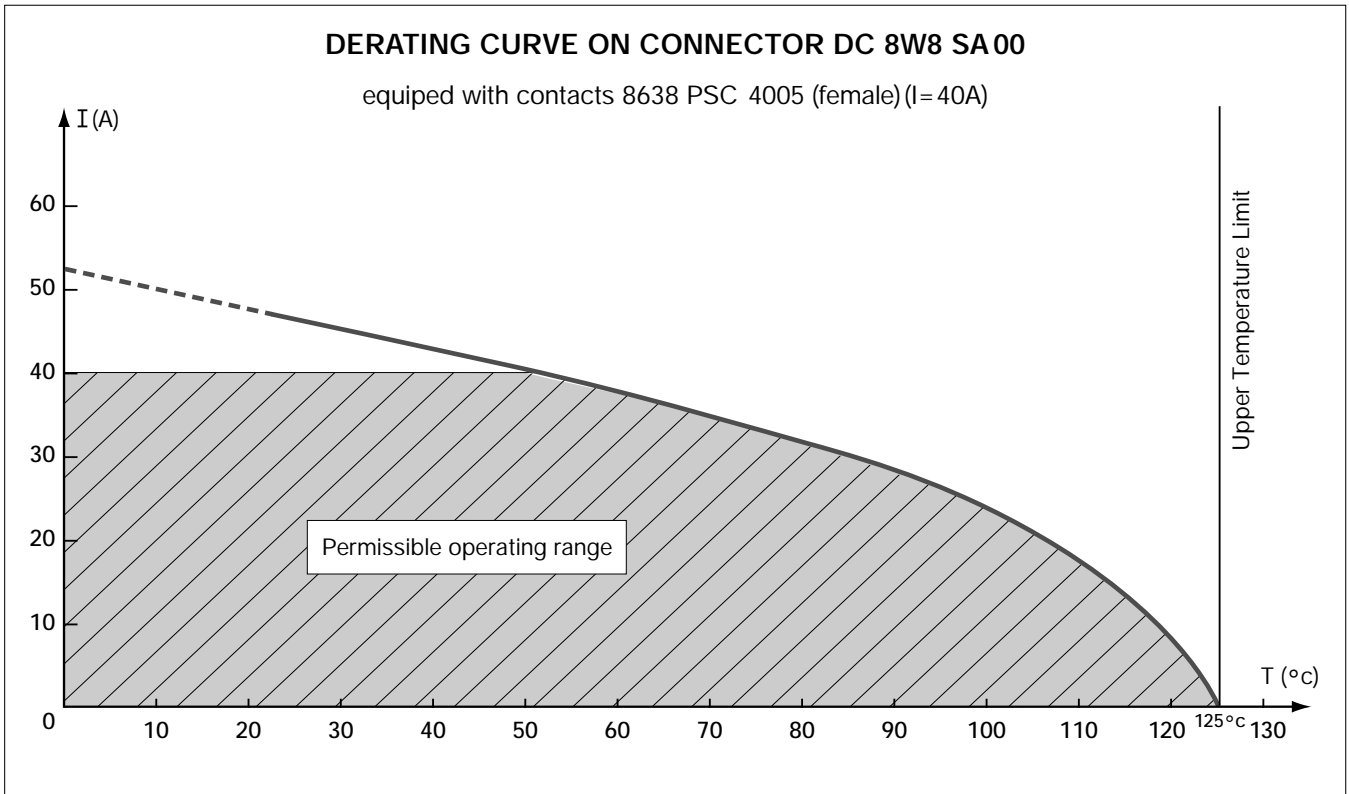

Mixed power DW series

Dimensions

PC board drilling

Solder termination

Version	Step	30 A	40 A
		Ø A	
3	2.84	Ø 2.40 \pm 0.10	Ø 3.10 \pm 0.10
7	2.84	Ø 2.40 \pm 0.10	
5	2.54	Ø 2.40 \pm 0.10	Ø 3.10 \pm 0.10

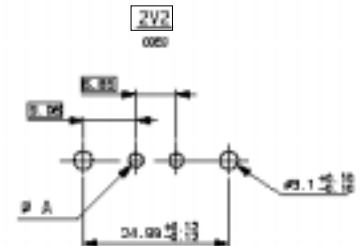
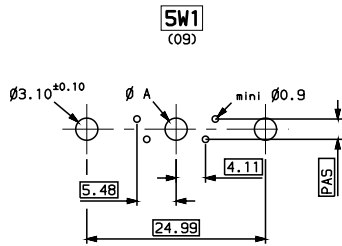

11W1
(15)

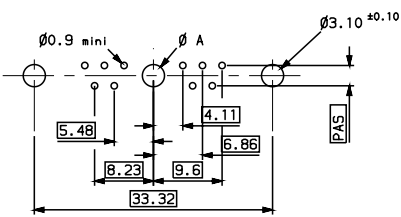

7W2
(15)

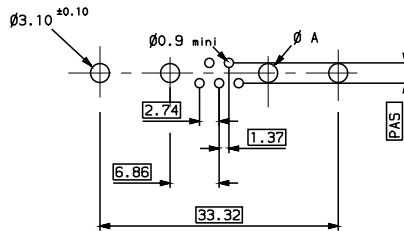

3V3
3W3
(15)

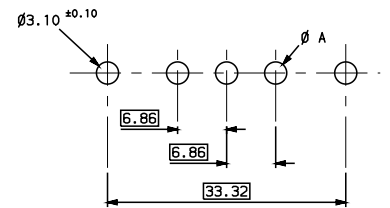

21W1
(25)

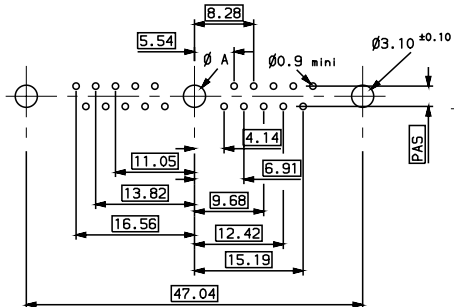

17W2
(25)

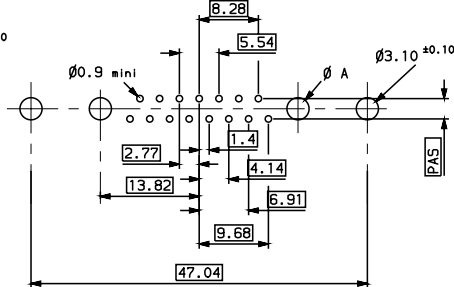

5W5
(25)

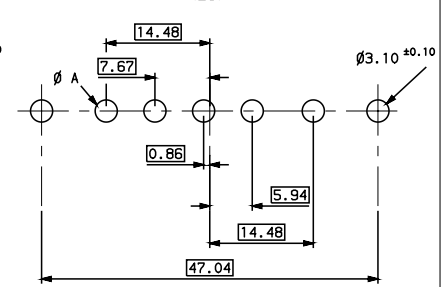

13W3
(25)

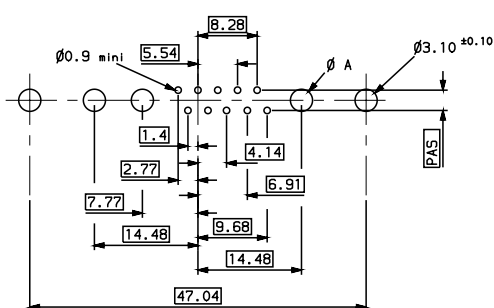

9W4
(25)

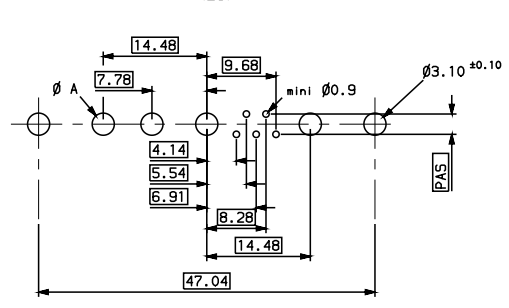

Mixed power DW series

Dimensions

PC board drilling

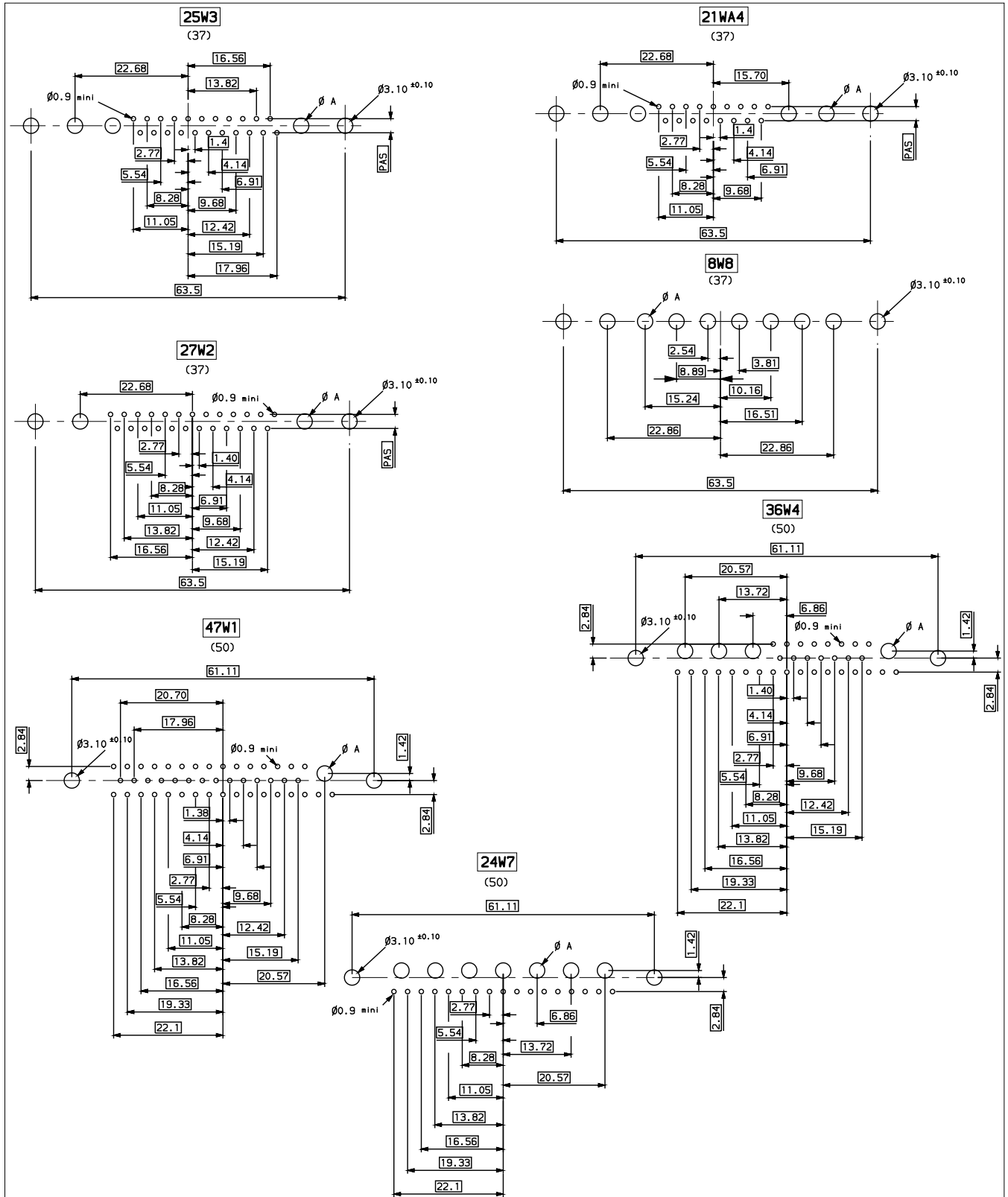

Mixed power DW series solder

 UL Recognized File E 118235 (R)

Straight and right angle PC board versions



Ordering information

Series	D	B	L	13	W	3	P	3	00	G	30
Shell size (tin plated) E, A, B, C, D (only straight version)											
Options 1 (see page 61)											
	Blank	L	O	I	V	Blank : without accessory L : Threaded insert M3 O : Threaded insert UNC 4.40 I : Female screw M3 V : Female screw UNC 4.40					
Straight version		X	X	X	X						
Right angled	X	X	X	X	X						
X : Available											
Layout of contacts (see page 20) (for right angled versions, 47W1, 24W7, 36W4 non available)											
Contacts P : Pin S : Socket											
Termination type 3 : Straight version 5 : Right angled / Europe standard 7 : Right angled / US standard (5W1, 9W4 non available)											
Plating 00 : 200 Mating / unmating 43 : 500 Mating / unmating											
Options 2 (see page 61) PCB accessories											
	A	H	G	M	A : without accessory on PCB H : Locking device used for PCB thickness 2.4 mm G : Locking device used for PCB thickness 1.6 mm M : Metal brackets						
Straight version	X	X	X								
Right angled	X	X	X	X							
X : Available											
Power contacts 30 : Fitted with power contacts 30 Amp. 40 : Fitted with power contacts 40 Amp. (not available in termination type US standard) 00 : Without power contacts											

Technical characteristics – page 6

Mixed power DW series solder

Specific dimensions

Straight version

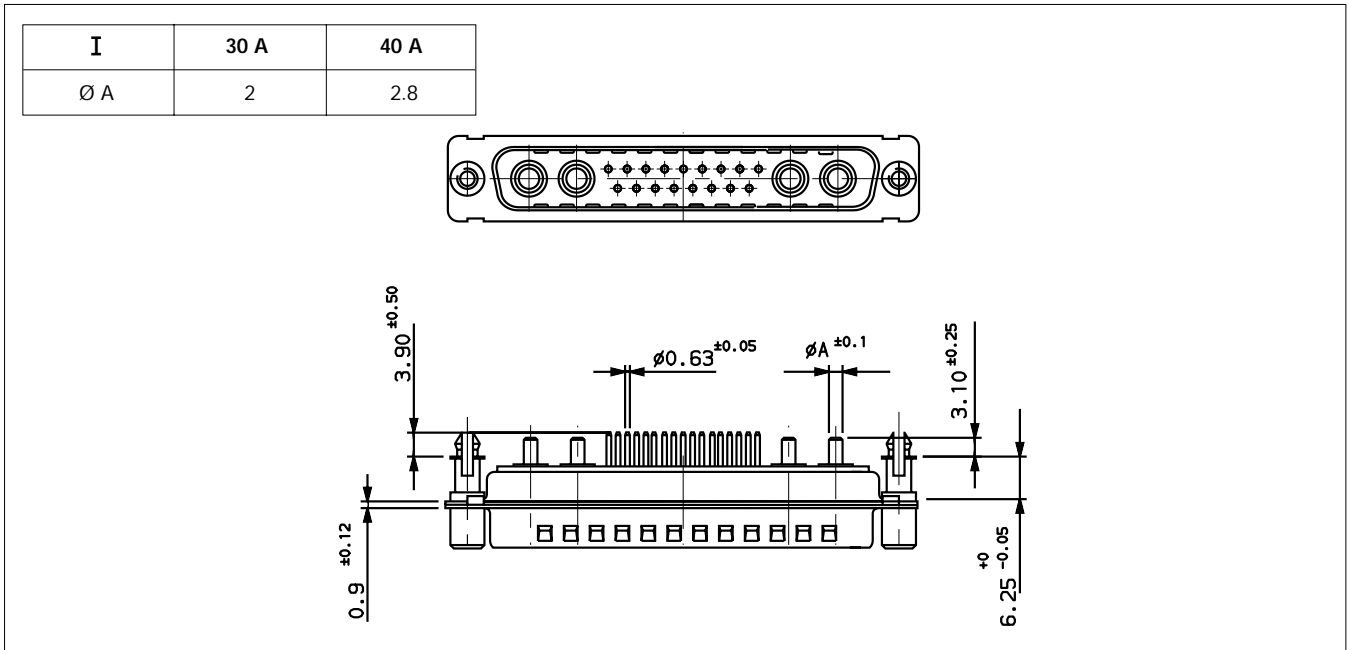

Angled version

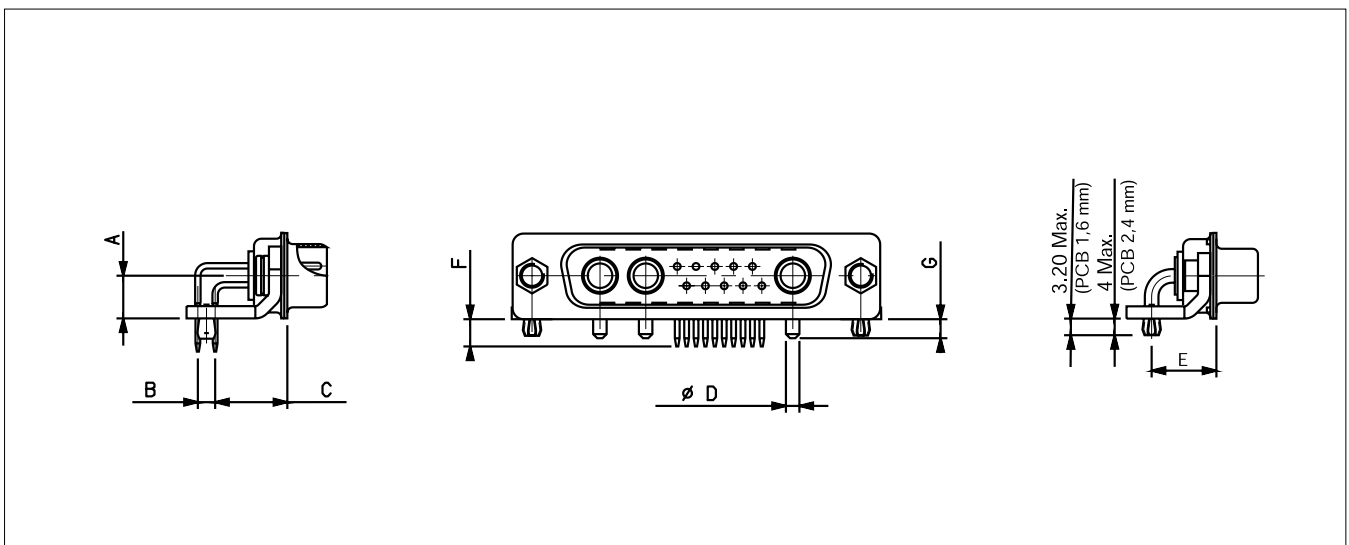

	Termination type	Amp.	A±0.10	B±0.20	C±0.20	D±0.10	E±0.20	F±0.50	G±0.30
Europe	5...	30 A	7.20	2.54	10.30	2.00	11.65	4.00	3.60
		40 A	7.20	2.54	10.30	2.80	11.65	4.00	3.60
U.S	7...	30 A	6.30	2.84	8.08	2.00	9.50	3.90	3.60

Mixed power DW series

 UL Recognized File E 118235 (R)

Cable versions connectors



Ordering information (power contacts have to be ordered separately — see next page)

Series	D	B	L	13	W	3	P	4	00	A	00
Shell size (tin plated) E, A, B, C, D											
Mounting option 1 (see page 61) connector accessories											
	Blank	L	O	I	V	F	Blank : without accessory L : Threaded insert M3 O : Threaded insert UNC 4-40 I : Female screw M3 V : Female screw UNC 4-40 F : Float mounting				
Solder buckets	X	X	X	X	X	X					
Wire-wrap	X	X	X	X	X	X					
X : Available											
Layout of contacts (see page 20)											
Contacts											
P	: Pin										
S	: Socket										
Termination type											
0	: Solder bucket (blank for plating 00)										
4	: Wire-wrap (3 levels)										
Plating											
00	: 200 Mating / unmating (blank for solder bucket termination)										
43	: 500 Mating / unmating										
A : without accessory on PCB											
Power contacts											
00	: Without power contacts										

Technical characteristics – page 6

Mixed power DW series

Specific dimensions

Solder bucket

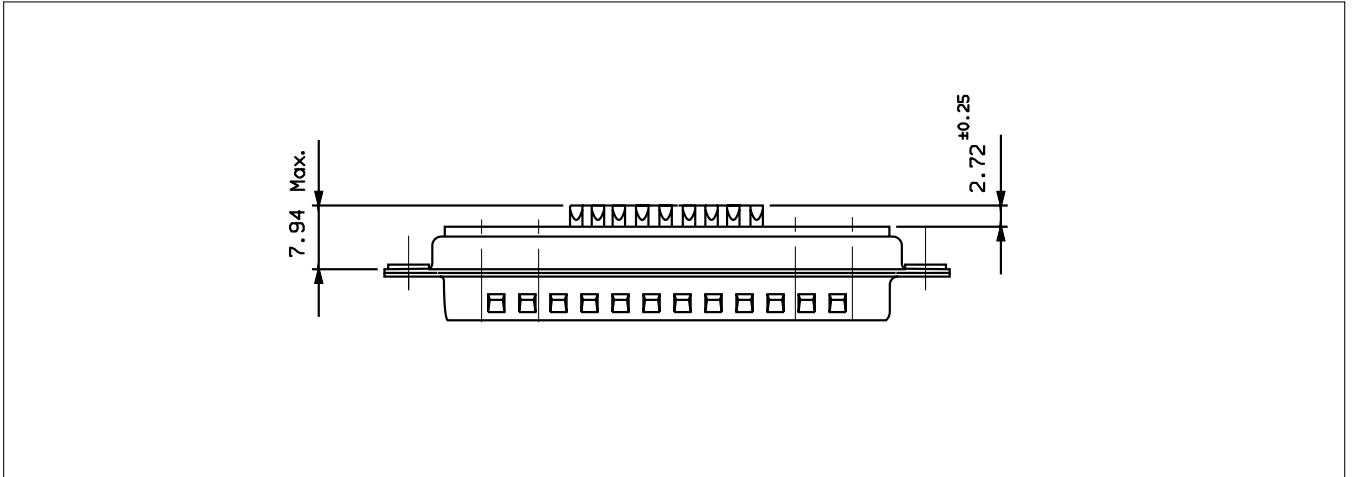

Wire wrap

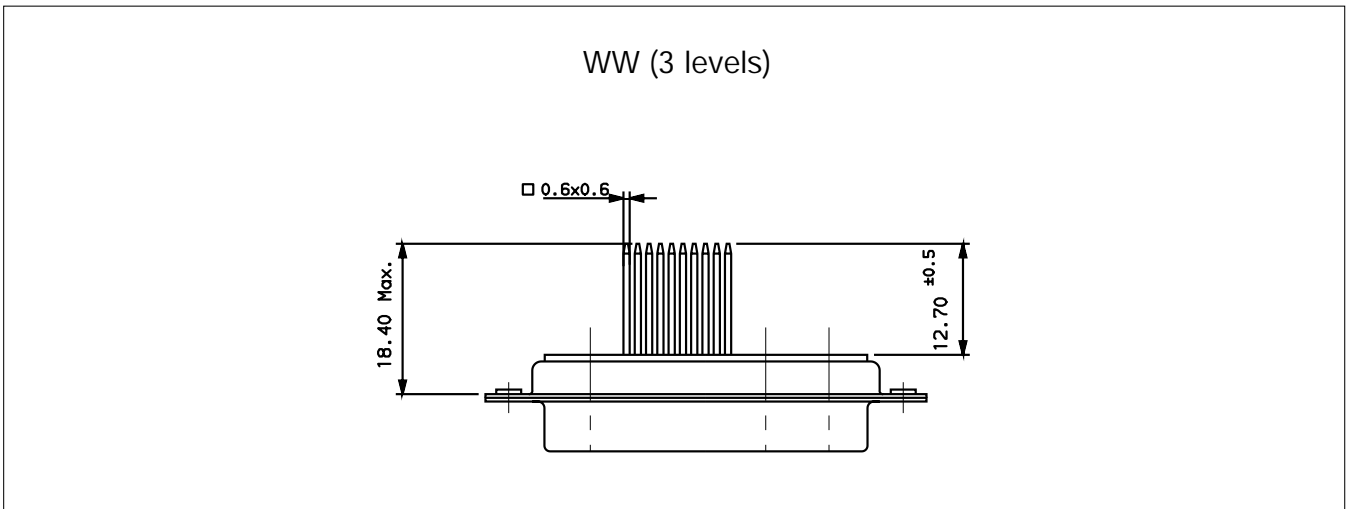

Solder version

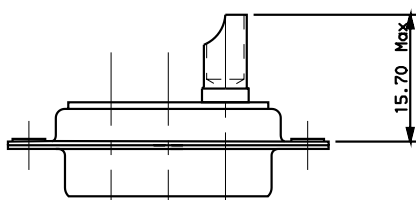

Crimp version

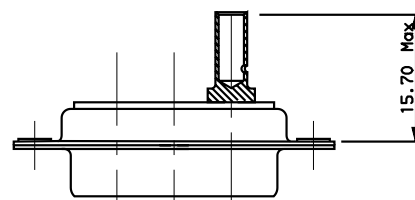

DW series Power solder and crimp

Power contacts

Solder contacts

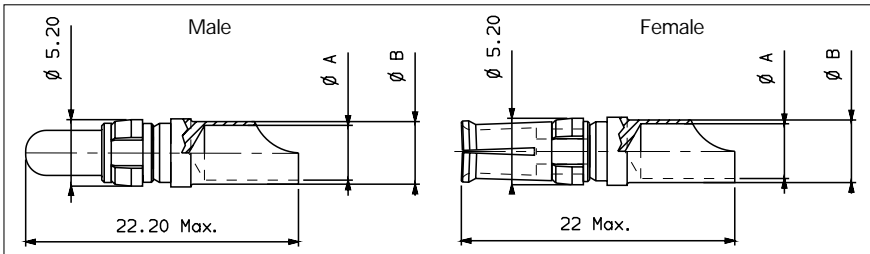

Type	Max. current rating	Clip colour	Part number ≥ 200 mating/unmating	Part number ≥ 500 mating/unmating	Wire		Strip length mm _{-0.5} ^{+0.5}	Ø A ₀ ^{+0.1}	Ø B ^{+0.05}
					Size	section mm ²			
Male	10A	Black	8638PPS1005	8638PPS1006	16	1.3	7	1.7	2.6
Male	15A	White	8638PPS1505	8638PPS1506	14	1.9	7	2.1	3
Male	20A	Red	8638PPS2005	8638PPS2006	12	3.2	7	2.8	3.65
Male	40A	Blue	8638PPS4005	8638PPS4006	8	9	7	4.4	5
Female	10A	Black	8638PSS1005	8638PSS1006	16	1.3	7	1.7	2.6
Female	15A	White	8638PSS1505	8638PSS1506	14	1.9	7	2.1	3
Female	20A	Red	8638PSS2005	8638PSS2006	12	3.2	7	2.8	3.65
Female	40A	Blue	8638PSS4005	8638PSS4006	8	9	7	4.4	5

- Clip material: plastic withstanding 125° C

- Termination plating: tin lead

- Packaging: 100 pieces

Crimp contacts

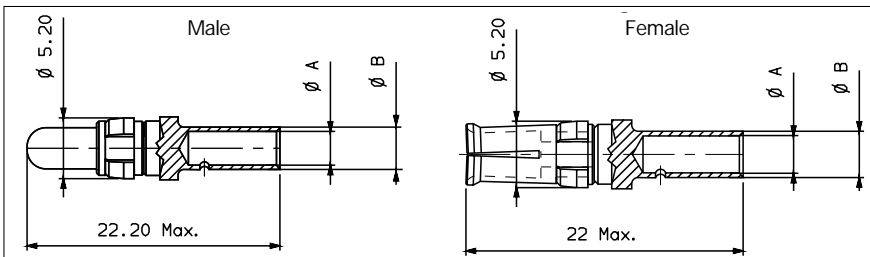

Type	Max. current rating	Clip colour	Part number ≥ 200 mating/unmating	Part number ≥ 500 mating/unmating	Wire		Strip length mm _{-0.5} ^{+0.5}	Ø A ₀ ^{+0.1}	Ø B ^{+0.05}
					Size	section mm ²			
Male	10A	Black	8638PPC1005	8638PPC1006	16 to 18	0.9 to 1.3	7	1.8	2.55
Male	20A	Red	8638PPC2005	8638PPC2006	12 to 14	2 to 3	7	2.8	3.7
Male	30A	White	8638PPC3005	8638PPC3006	9	6	7	3.75	4.65
Male	40A	Blue	8638PPC4005	8638PPC4006	8 to 10	5 to 8	7	4.8	5.5
Female	10A	Black	8638PSC1005	8638PSC1006	16 to 18	0.9 to 1.3	7	1.8	2.55
Female	20A	Red	8638PSC2005	8638PSC2006	12 to 14	2 to 3	7	2.8	3.7
Female	30A	White	8638PSC3005	8638PSC3006	9	6	7	3.75	4.65
Female	40A	Blue	8638PSC4005	8638PSC4006	8 to 10	5 to 8	7	4.8	5.4

- Clip material: plastic withstanding 125° C

- Termination plating: tin lead

- Packaging: 100 pieces

Tooling

- Extraction tool : 8630 07

- Crimping tool : 8638 CTP 01

DELTA D



Full power right angled solder

 UL Recognized File E 118235 (R)

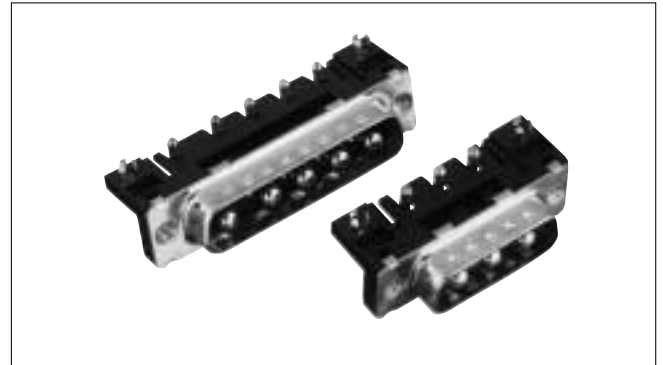
This monobloc insulator design with stamped and formed signal contacts combines performance and cost effectiveness.



Part number

Series	D	3	W	3	P	36 A	6	GX	08
		5	W	5					
Layout									
Contact									
P	: Male								
Termination type									
Code	Type	Foot print	Length of termination	PCB thickness					
36 A	Right angle, US standard, solder	8.08 mm	2.50	1.6					
Plating									
6	: High performances class (500 ≤ mating / unmating)								
Mounting options (see page 62)									
Options	Description								
GL	Harpoon + insert M3 + elec. continuity								
 GX	Harpoon + insert UNC 4-40 + elec. continuity								
 GV	Harpoon + Female screw UNC 4-40 + elec. continuity								
Power contacts									
08	: Fitted with power contacts 30 A								

For other technical characteristics, see page 6 - For other dimensions and layouts, see page 20.

Specific dimensions

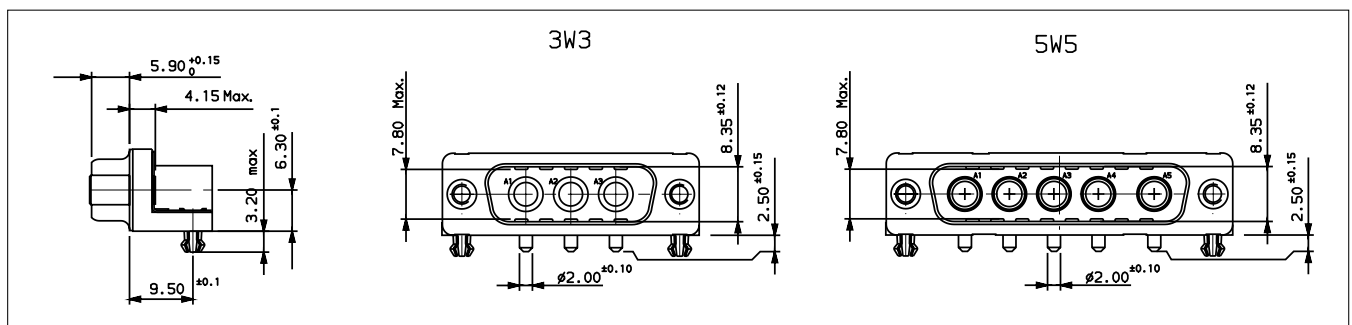

 Preferred option

DW series

Full power right angle and straight press-fit

 UL Recognized File E 118235 (R)



Part number

Series		D	E	L	2	V	2	P	93C	5	G	40
Shell size (tin plated) E, A, B, C					3	V	3					
					5	W	5					
					8	W	8					
Front accessory												
	Blank	L	O	V								
Straight version		X	X	X								
Right angled	X	X	X	X								
X : available												
					L							
					O							
						V						
Blank : Without accessory												
L : Threaded insert M3												
O : Threaded insert UNC 4-40												
V : Female screw UNC 4-40												
Layout												
Contacts												
P : Pin												
S : Socket												
Termination type												
93 C : Straight version												
81 C : Right angle / European standard												
80 C : Right angle / US standard												
Plating												
5 : 200 mating / unmating												
6 : 500 mating / unmating												
PCB accessory												
	M	G	A									
Straight version		X										
Right angled	X		X									
A : without accessory												
G : Harpoon used for PCB thickness from 1.6 mm												
M : Metal brackets without harpoon												
					A							
						G						
							M					
Power contacts												
40 : Fitted with power contacts 40 Amp.												

For other technical characteristics, see page 6 - For other dimensions and layouts, see page 29 and 30.

DW series

Full power right angle and straight press-fit

Specific dimensions

- Metallized hole dimensions

		Press-fit contacts	Press-fit harpoons
P.C.B. hole definition (note 1 and 2)	Drill diameter	Ø 3.22 ^{+0.03}	Ø 3.22 ^{+0.03}
	Drilled hole	Ø 3.19 - 3.25	Ø 3.19 - 3.25
	Tin-lead plating	25 µ max (recommended 50 µ max)	25 µ max (recommended 50 µ min)
	Finish hole (after reflow)	15 µ max (recommended 5 µ min)	15 µ max (recommended 5 µ min)
	Copper plating	Ø 3.02 - 3.20	Ø 3.02 - 3.20

Note 1 : These dimensions must be respected to ensure press-fit pin performance

Note 2 : According to IEC-352-S specification

Note 3 : Vital requirement for press-fit pin performance

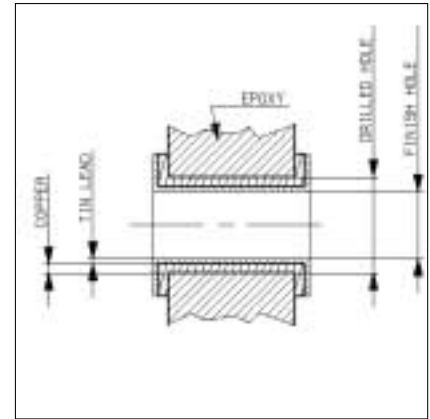

- Press-fit performance

	Press-fit contacts	Press-fit harpoons
Insertion force	≤ 200 N (average insertion 160N)	≤ 200 N (average insertion 160N)
Extraction force	≥ 30 N	≥ 30 N

D series

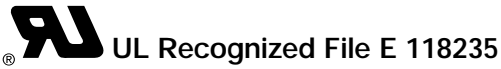

D series is the standard D.Sub full metal shell version with stamped contacts. This design is basically proposed in solder bucket, straight and angled version without accessories.



Ordering information

Series	D	B	25	P	5	64	C	T	X
Shell size E, A, B, C, D									
Number of contacts 09, 15, 25, 37, 50									
Contacts P : Pin S : Socket									
Termination type 0 : Solder bucket 3 : Straight 5 : Angled	} Stamped contacts								
Plating 64 : ≥ 200 mating / unmating 65 : ≥ 500 mating / unmating									
Options 2 (see page 61)									
Termination type Index	Straight version	Angled version	Solder buckets						
Blank	Without accessory	Not possible	Without accessory						
C	Not possible	Without bracket	Not possible						
H*	Not possible	Not possible	Shielding termination fingers*						
* not available on 50 way									
Shell plating T	: Standard tin plating								
Dimples X	: Standard for male connector only								

D series

Specific dimensions

Solder buckets

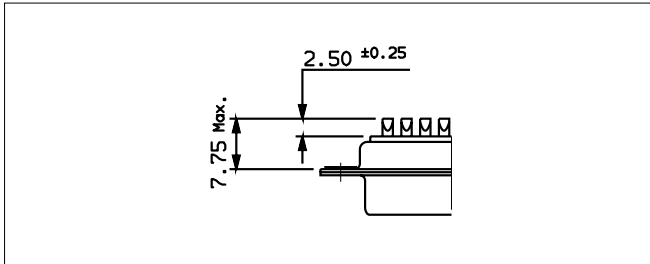

Straight spills

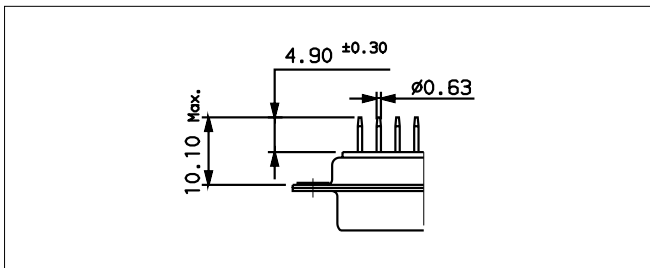

Angled spills

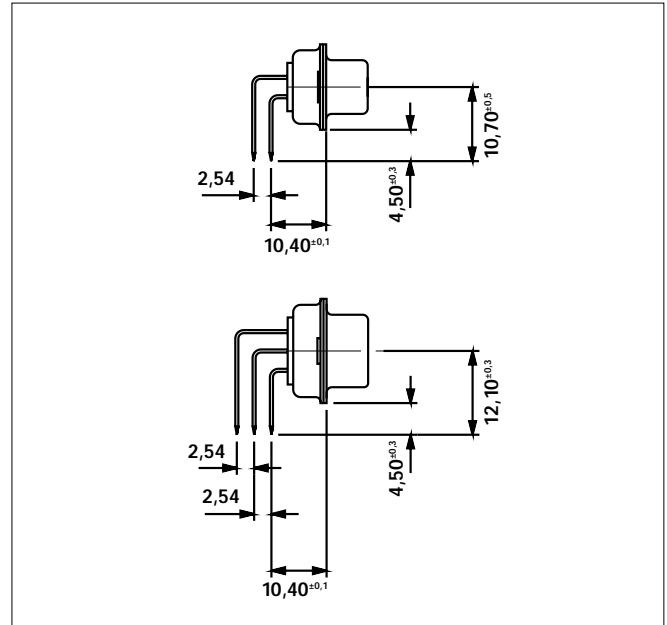

8656 series



8656 series is a D connector with removable crimp contacts for AWG 20/24 or 24/28 wires. It is used for commercial cabling like computer equipment, cash registers... It accepts our standard accessories (hoods, locking devices) and is available with a complete range of crimping tools from hand tools to high volume production equipment.



Ordering information

Connector part numbers

Series	8656	0	25	P	L	T	X
Options 1 (see page 61)							
Blank	: Standard mounting hole (Ø = 3.10)						
O	: Clinch nuts UNC 4-40						
Number of contacts	9, 15, 25, 37, 50						
Contacts							
P	: Pin						
S	: Socket						
L	: Supplied without contacts (obligatory)						
Shell plating							
T	: Standard tin plating						
Dimples							
X	: Standard on male shell only						

Contact part numbers

Contact type	Packaging type	😊			
		Box of 500 contacts	Reel of 400 contacts	Reel of 5000 contacts	Reel of 10 000 contacts
AWG 24/28 male		8656 350 06 ▲	8656 3003 06 ▲	8656 4510 06 ▲	8656 4540 06 ▲
AWG 24/28 female		8656 351 06 ▲	8656 3004 06 ▲	8656 6510 06 ▲	8656 6540 06 ▲
AWG 20/24 male		8656 352 06 ▲	8656 3005 06 ▲	8656 4520 06 ▲	8656 4530 06 ▲
AWG 20/24 female		8656 353 06 ▲	8656 3006 06 ▲	8656 6520 06 ▲	8656 6530 06 ▲

▲ Contact plating: 4: ≥ 200 matings / unmatings
5: ≥ 500 matings / unmatings

8656 series

Specific dimensions

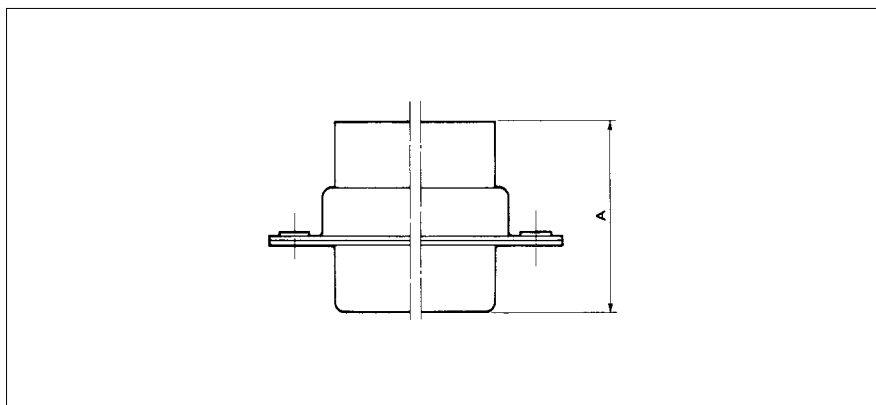

		09	15	25	37	50
A_{Max.}	P	17.19	17.19	17.35	17.35	17.35
	S	17.44	17.44	17.44	17.44	17.44

Tooling

- Metal contact insertion and extraction tool	8656 - 3007 A
- Pliers <ul style="list-style-type: none"> • manual crimp tool for 400 contacts reel • manual crimp tool for loose contacts 	8656 - 3001 8656 - 3005
- Automatic pneumatic strip and crimp equipment (1000 crimps per hour) <ul style="list-style-type: none"> • automatic crimp machine • die sets for AWG 20 / 24 contacts • die sets for AWG 24 / 28 contacts 	8506 - 8000 8656 - 5656 B 8656 - 5656 S)



Cable preparation

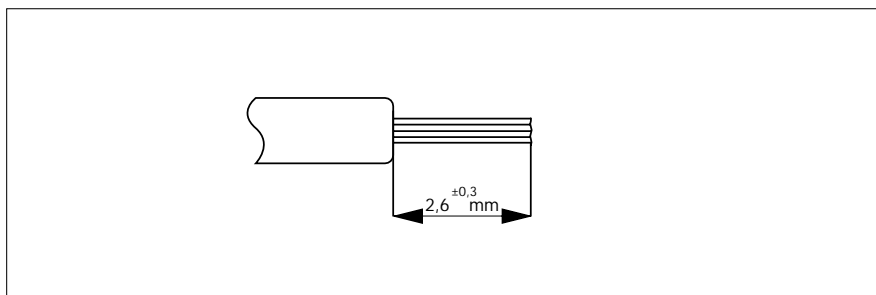

8657 series

Insulation displacement connection for flat cable,
multistrand (AWG 26/28) or single strand (AWG 28/30)



These connectors are suitable for input/output applications and interconnecting electronic equipment.

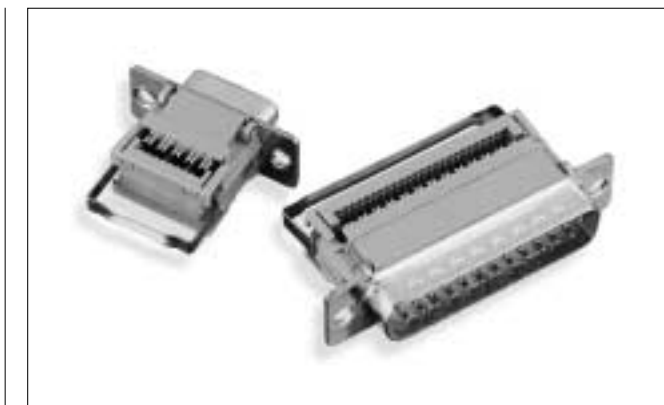

Ordering information

Series	8657	25	P	0	65	T	X
Number of contacts 9, 15, 25, 37							
Contacts P : Pin S : Socket	} Stamped and rolled contacts						
Standard version							
Plating 65	: 500 mating / unmating						
Shell plating T	: Standard tin plating						
Dimples X	: Standard on male connector only						

Technical characteristics - see page 6

8657 series

Layouts

Male insulator front view

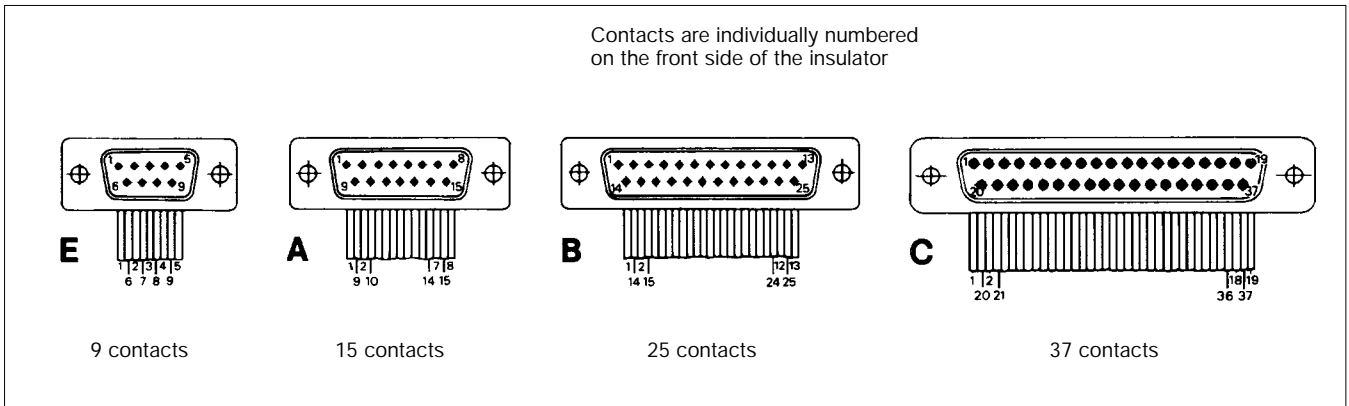

Specific dimensions

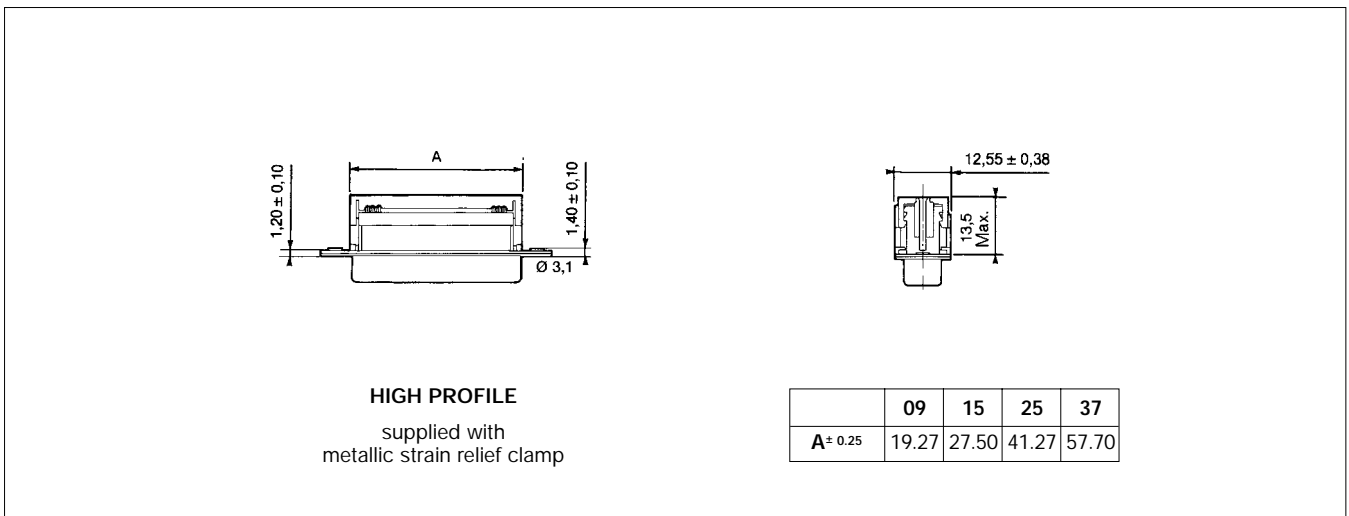

COMPACT D

 UL Recognized File E 118235 (R)

COMPACT D Series has been developed to answer the increasing need for higher density packaging.



Ordering information

Series	ICD	14	S	13 E	6	GX	00
Number of contacts 14, 15							
Contacts S : Female							
Termination 13E : Angled spills US Standard							
Plating 4 : Standard class (≥ 200 mating / unmating) 6 : High performance class (≥ 500 mating / unmating)							
Mounting options (see cover page 62) GX : Harpoons + insert UNC 4-40 GV : Harpoons + female screw UNC 4-40							} These options offer electrical continuity
Options 00 : Standard series							

Technical characteristics – page 6

COMPACT D

Specific dimensions

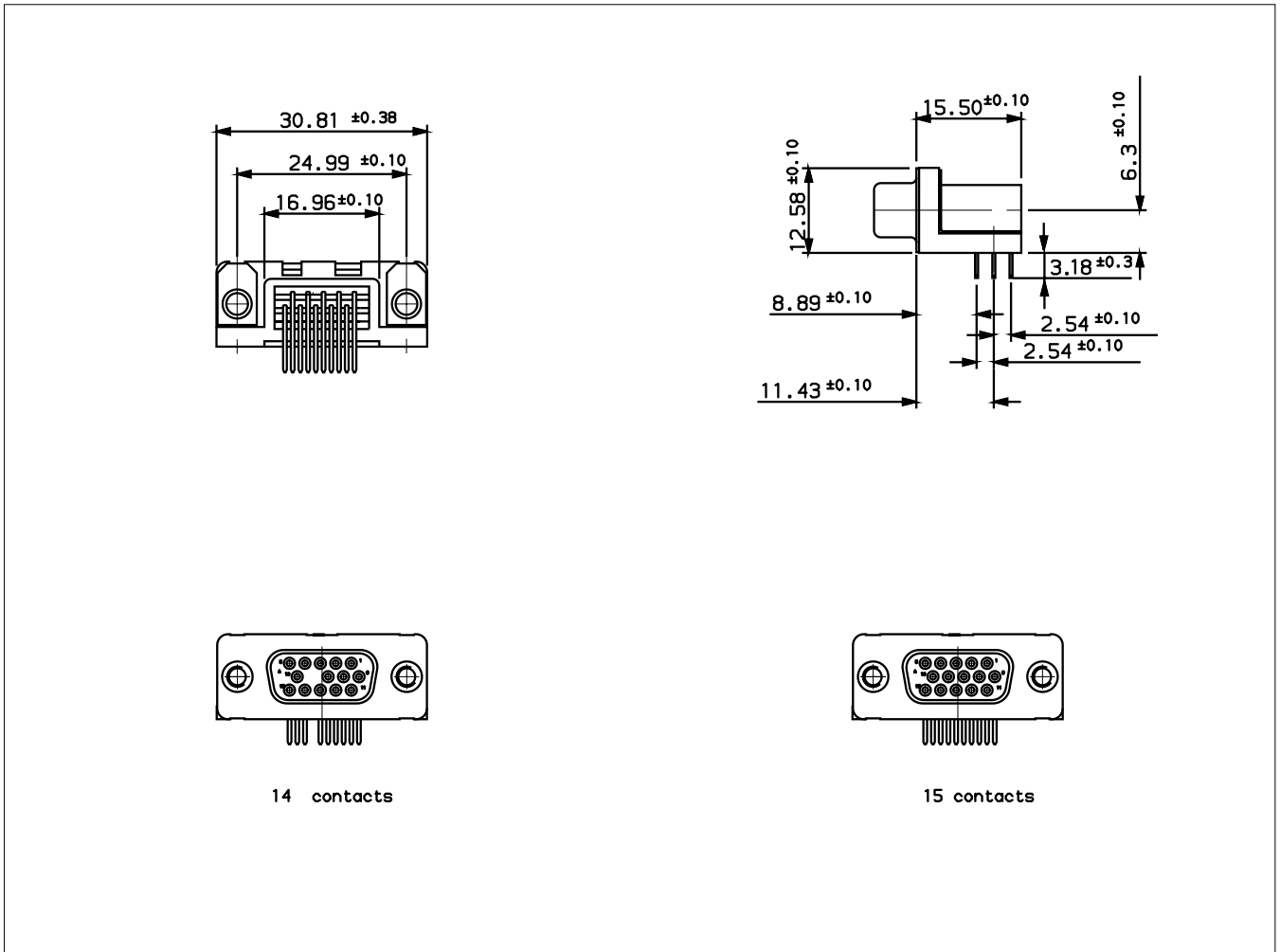

PCB drilling dimensions

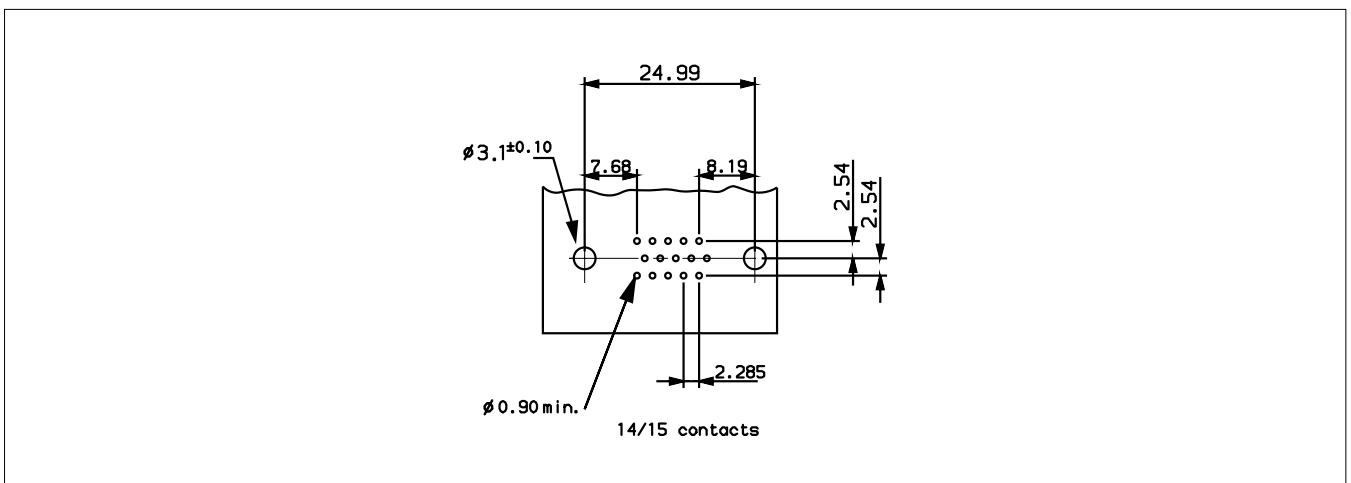

DP series



UL Recognized File E 118235

DP series is designed for high performance applications, particularly in the field of telecommunications: data transmission, private automatic branch switching, telecom (LNZ listed). It features machined contacts and is available with solder bucket, straight spills, angled spills, and wirewrap terminations.



Ordering information

Series	D	B	P	V	25	P	5	00	M	T	X
Shell size E, A, B, C, D											
P	: Characterisation of DP series										
Options 1 (see cover page 61)											
Blank	: Standard mounting holes (Ø = 3.10)										
L	: Clinch nuts M3										
V	: Female screw locks UNC 4-40										
S	: Spacers (straight spills only)										
Number of contacts 09, 15, 25, 37, 50											
Contacts											
P	: Pin										
S	: Socket										
Termination											
0	: Solder buckets (blank for plating 00)										} Machined contacts
3	: Straight spills										
5	: Angled spills										
4	: Wire wrap (3 levels)										
6	: Wire wrap (2 levels)										
Plating											
31	: ≥ 200 mating / unmating										
00	: ≥ 500 mating / unmating, blank for solder bucket termination										
Options 2 (see cover page 61)											
Index \ Termination type	Straight spills	Angled spills	Solder buckets	Wire wrap							
Blank	Without accessory	Two plastic brackets*	Without accessory	Without accessory							
C	Not applicable	Without brackets	Not applicable	Not applicable							
M	Not applicable	Two metal brackets	Not applicable	Not applicable							
G	Harpoons*	Harpoons	Not applicable	Not applicable							
	*(Compulsary with option L or V)	(9 to 37 ways only)									
*except 50 pos. with monobloc plastic brackets											
Shell plating											
T	: Standard tin plated										
Dimples											
X	: Standard on male connectors only										

DP series

Specific dimensions

Solder buckets

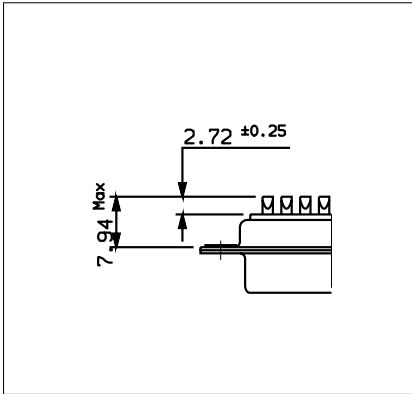

Wire wrap

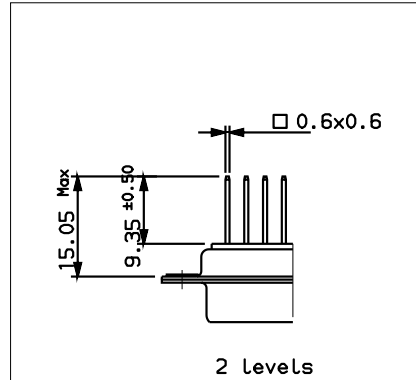

Angled spills

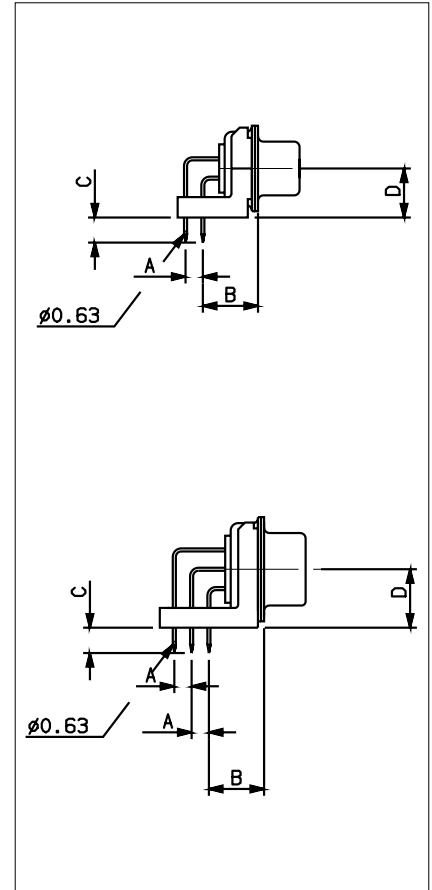

Straight spills

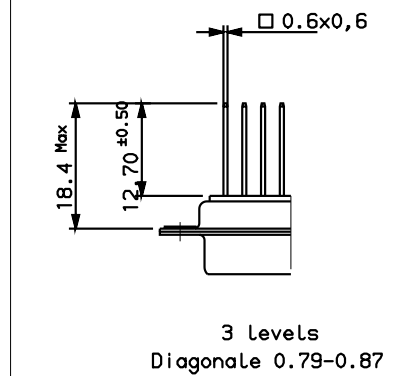
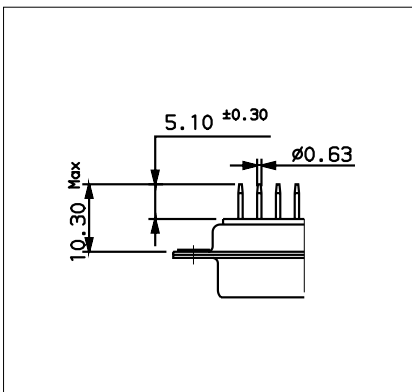

Termination	5
Dimension	
A	2.54
B± 0.1	10.30
C± 0.5	4.00
9 to 37 contacts	7.20
D± 0.1	8.60
50 contacts	

DM series HE 501



UL Rating Product File E 118235 (R)

For aerospace, military 125° class-European standard in compliance with NFC 93425 / HE 501.

Shell plating: Cadmium



Ordering information

Series	D	B	M	L	25	P	5	00	M
Shell size	E, A, B, C, D								
M: Characterisation of Military series									
Options 1 (see cover page 61)									
Blank	: Standard mounting holes ($\varnothing = 3.10$)								
L	: Clinch nuts M3								
F	: Float mounting								
Number of contacts									
09, 15, 25, 37, 50									
Contacts									
P	: Pin								
S	: Socket								
Termination									
Blank	: Solder buckets								
3	: Straight solder spills								
5	: Angled solder spills								
4	: Wire wrap (3 levels)								
Plating									
00	: Standard = Gold / Nickel (active areas) - Tin lead (termination) blank for solder buckets termination.								
Others	: please, consult us								
Options 2 (see cover page 61)									
Option	Version	Angled spills	Other terminations						
Blank		Plastic brackets	Not applicable						
C		Without brackets	Not applicable						
M		Metal brackets	Not applicable						

Technical characteristics – page 7

DM series HE 501

Specific dimensions

Solder buckets

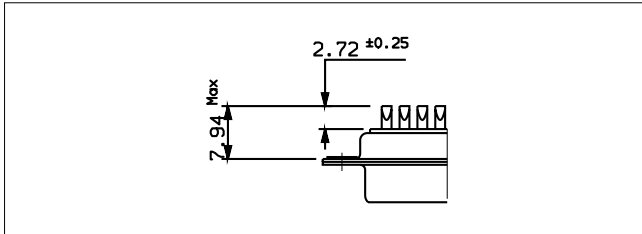

Cross reference list for the main HE 501 and FCI

Connector type			HE 501	FCI
Solder buckets	Standard	M	HE 501 N..AP3	D.M..P
		F	HE 501 N..AS3	D.M..S
	Float mounting	M	HE 501 F..AP3	D.MF..P
		F	HE 501 F..AS3	D.MF..S

Straight spills

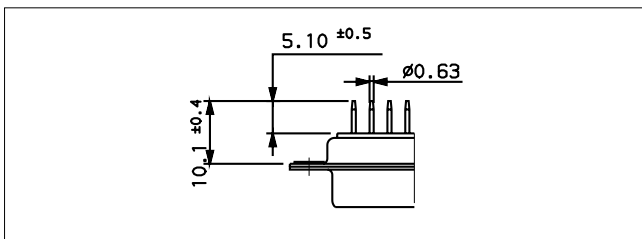

Connector type			HE 501	FCI
Straight spills	Standard	M	HE 501 N..YP4.3	D.M..P 300
		F	HE 501 N..YS4.3	D.M..S 300
	Float mounting	M	HE 501 F..YP4.3	D.MF..P 300
		F	HE 501 F..YS4.3	D.MF..S 300

Wire wrap

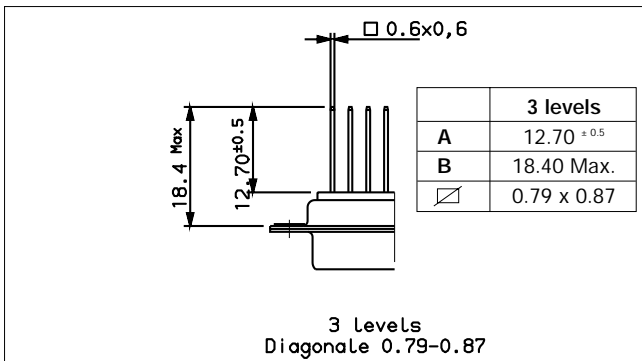

Connector type			HE 501	FCI
Wire wrap 3 levels	Standard	M	HE 501 N..KP3.3	D.M..P 400
		F	HE 501 N..KS3.3	D.M..S 400
	Float mounting	M	HE 501 F..KP3.3	D.MF..P 400
		F	HE 501 F..KS3.3	D.MF..S 400

Angled spills

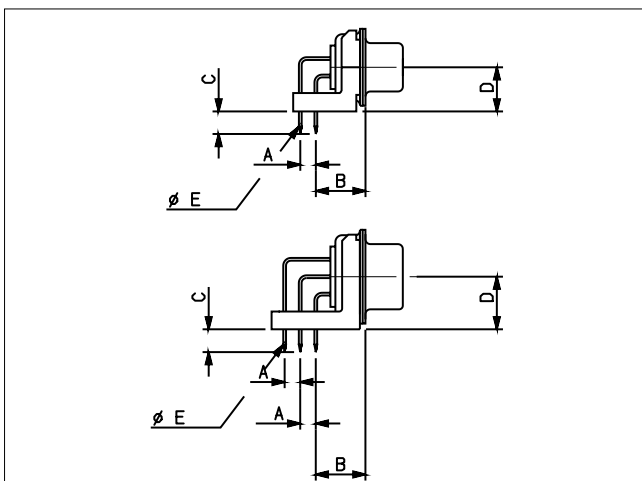

Connector type			HE 501	FCI
Angled spills 500	Standard	M	HE 501 P..VP6.3	D.M..P 500
		F	HE 501 P..VS6.3	D.M..S 500
	Metal brackets	M	HE 501 M..VP6.3	D.M..P 500M
		F	HE 501 M..VS6.3	D.M..S 500M

Dimension	Termination	5
A		2.54
$B \pm 0.1$		10.30
$C \pm 0.5$		4.00
$D \pm 0.1$	9 to 37 contacts	7.20
	50 contacts	8.60
$\varnothing E$		0.63

DM series HE 508



UL Rating Product File E 118235 (R)

For particularly severe applications, especially high temperatures class + 155°C in compliance with NFC 93425 / HE 508.

Shell plating: Cadmium



Ordering information

Series	D	B	M		25	P	5	00	M	N
Shell size E, A, B, C, D										
M: Characterisation of Military series										
Options 1 (see cover page 61) Blank : Standard mounting holes (Ø = 3.10) F : Float mounting										
Number of contacts 09, 15, 25, 37, 50										
Contacts P: Pin S: Socket										
Termination Blank : Solder buckets 3 : Straight solder spills 5 : Angled solder spills 4 : Wire wrap (3 levels)										
Plating 00 : Standard = Gold / Nickel (blank for solder buckets termination) Others : please, consult us										
Options 2 (see cover page 61)										
	Version	Angled spills	Other terminations							
Option										
Blank		Plastic brackets	Not applicable							
C		Without brackets	Not applicable							
M		Metal brackets (male only)	Not applicable							
N: Obligatory for HE 508										

Technical characteristics – page 7

DM series HE 508

Specific dimensions

Solder buckets

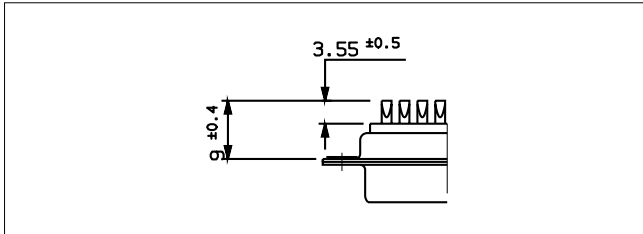

Cross reference list for the main HE 508 and FCI

Connector type			HE 508	FCI
Solder buckets	Standard	M	HE 508 N..AP	D.M..PN
		F	HE 508 N..AS	D.M..SN
	Float mounting	M	HE 508 F..AP	D.MF..PN
		F	HE 508 F..AS	D.MF..SN

Straight spills

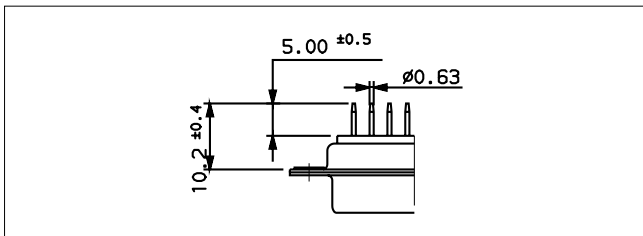

Connector type			HE 508	FCI
Straight spills	Standard	M	HE 508 N..YP4	D.M..P 300N
		F	HE 508 N..YS4	D.M..S 300N
	Float mounting	M	HE 508 F..YP4	D.MF..P 300N
		F	HE 508 F..YS4	D.MF..S 300N

Wire wrap

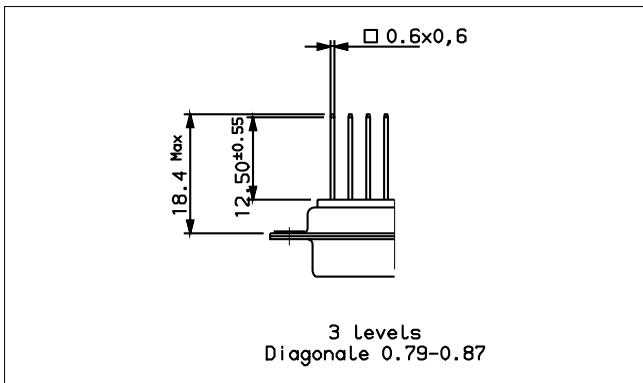

Connector type			HE 508	FCI
Wire wrap 3 levels	Standard	M	HE 508 N..KP3	D.M..P 400N
		F	HE 508 N..KS3	D.M..S 400N
	Float mounting	M	HE 508 F..KP3	D.MF..P 400N
		F	HE 508 F..KS3	D.MF..S 400N

Angled spills

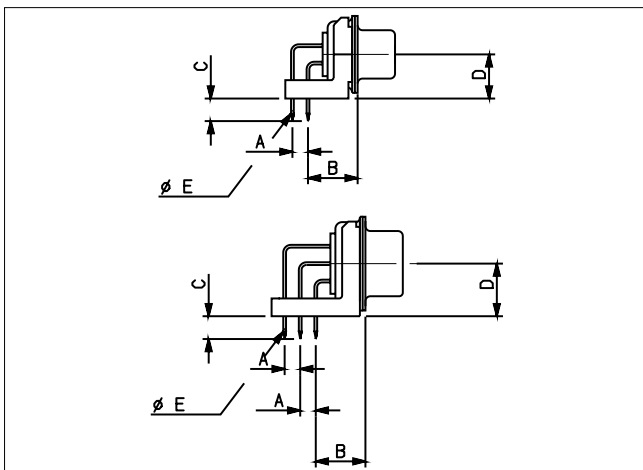

Connector type			HE 508	FCI
Angled spills 500	Standard	M	HE 508 P..VP6	D.M..P 500N
		F	HE 508 P..VS6	D.M..S 500N
	Metal brackets	M	HE 508 M..VP6	D.M..P 500MN
		F	HE 508 M..VS6	D.M..S 500MN

Dimension	Termination	5
A		2.54
B ±0.1		10.30
C ±0.5		4.00
D ±0.1	9 to 37 contacts	7.20
	50 contacts	8.60
Ø E		0.63

DMW series HE 507

 UL Rating Product File E 118235

Connectors drawn from DM series. Composed of mixed arrangements of standard signal and size 8 cavities housing, coax, power, high voltage and optical removable contacts (see page 46).

Shell plating: Cadmium



Ordering information

Series	D	B	M	13W3	P	5	00	M	N
Shell size E, A, B, C, D									
M: Characterisation of military series									
Options 1 (see cover page 61) Blank : Standard mounting holes (Ø = 3.10) F : Float mounting									
Layout of contacts see page 49									
Contacts P : Pin S : Socket									
Terminaison Blank : Solder buckets 3 : Straight solder spills 5 : Angled solder spills 4 : Wire wrap (3 levels)									
Plating 00 : Standard = Gold / Nickel on active areas - Tin lead on termination (blank for solder buckets termination)									
Options 2 (see cover page 61)									
Option \ Version	Angled spills		Other terminations						
Blank	Plastic brackets		Without accessory						
C	Without brackets		Not applicable						
M	Metal brackets		Not applicable						
N: Compulsary in compliance with HE 507									

Technical characteristics – page 7

DMW series HE 507

Layouts

Male insulator frontview

Shell size		Layout
E	5W1	
	11W1	
A	7W2	
	3W3	
	3V3	
B	21W1	
	17W2	
	13W3	
	9W4	
	5W5	

Shell size		Layout
C	25W3	
	21WA4	
	27W2	
	8W8	
D	47W1	
	24W7	
	36W4	

- Standard contacts
- Coaxial and power contacts

Specific dimension for standard terminations, see DM series, page 41

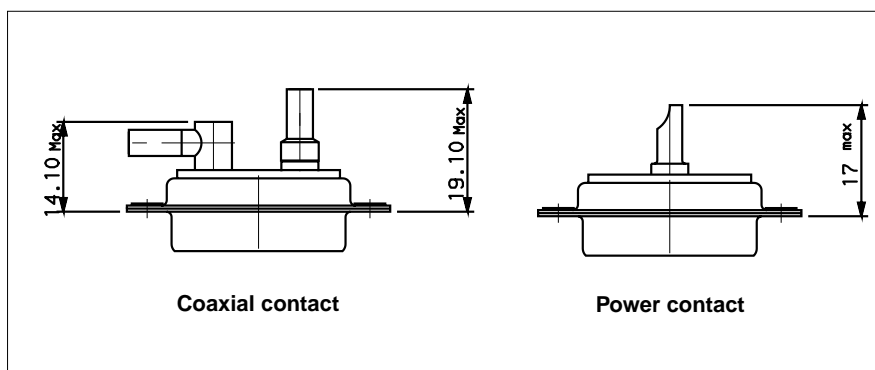

Tooling

Crimp tool : M22520/5-01

Locator :

Part number	Y278	Y197
Size of cable	RG178BU RG316U	RG180BU RG58CU

Extractor tool

- Coaxial contact : 8630-07A
- Power and high voltage contact: 8630-07

DMW series HE 507

Power contacts

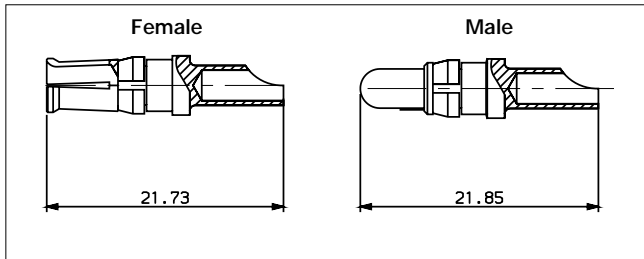

Wire Size	Max. current	Part numbers	
		Male	Female
AWG8	40A	8630-3098N	8630-3099N
AWG12	20A	8630-3056N	8630-3057N
AWG14	15A	8630-3060N	8630-3061N
AWG16	10A	8630-3064N	8630-3065N

Plating: 500 mating/unmating

High voltage contacts

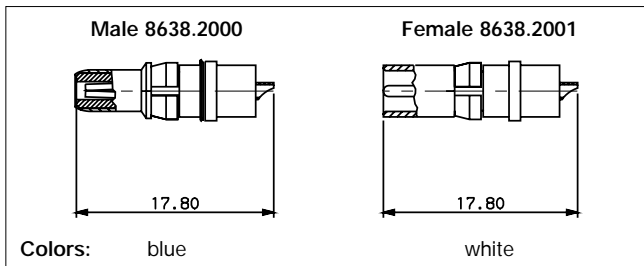

These removable contacts are suitable for the contact cavities of the DMW series and DW series.

The coaxial contacts are in compliance with:
 - NFC 93569
 - KMX4 specification

Electrical characteristic:

Dielectric with standing voltage: 2800 V.r.m.s
 Break down voltage: 3200 V.r.m.s
 Insulation resistance: 10^9 M Ω
 Contact resistance: ≤ 5 M Ω
 Max current rating: 5A
 Material: TEFLON

Mechanical characteristic:

Mating force per set of contact: 3N
 Mating endurance: 200
 Temperature: -55° C to + 125° C

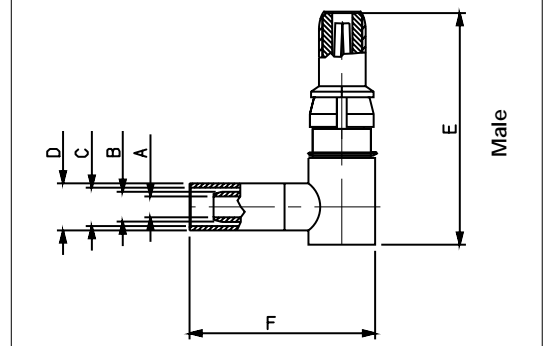
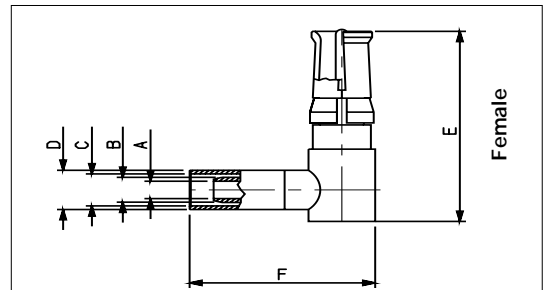
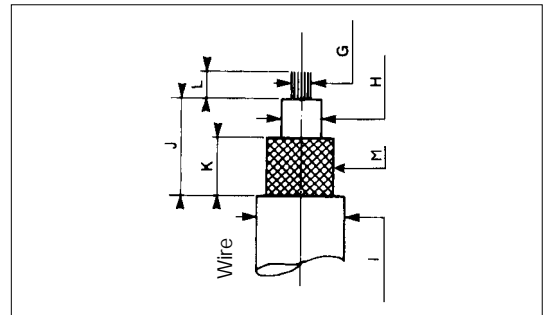

Angled

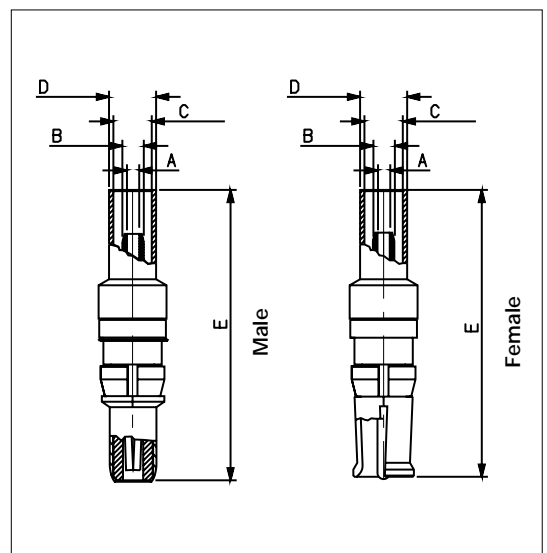

Coaxial contacts
 Straight

DMW series HE 507

Standard coaxial contacts

Contact type	Part numbers				Contacts dimension						Cable						Wire					
	Soldered screen	NFC 93569 KMX4	Crimped screen	NFC 93569 KMX4	A ^{+0.10}	B ^{+0.15}	C ^{+0.2}	D ^{+0.15}	E ^{+0.04}	F ^{+0.04}	MILC 17E	NFC 93550	Impe- dance	G	H	I	J	K	L	M (Max.)		
Straight	male	DM53740-5000NC	KMX4M11D02	DM53740NC	KMX4M12D02	1	1.75	2.32	3.20	23.60	RG 1788BU	KX21A	50Ω±2	0.30	0.90	1.80	7.90	6.35	2	1.40		
	male	DM53740-5008NC	—	—	—	—	—	21.80	21.80	—	—	—	—	—	—	—	—	—	—	—		
	female	DM53742-5000NC	KMX4F11D02	DM53742NC	KMX4F12D02	—	—	—	18.64	15.30	—	—	—	—	—	—	9.50	5.95	1.60	—		
	female	DM53742-5006NC	—	—	—	—	—	—	18.64	15.30	—	—	—	—	—	—	—	—	—	—	—	
Angled	male	DM53741-5000NC	KMX4M11C02	DM53741-1NC	KMX4M12C02	—	—	—	23.60	—	—	—	—	—	—	—	7.90	6.35	2.00	—		
	female	DM53742-5000NC	KMX4F11C02	DM53742-2NC	KMX4F12C02	—	—	—	23.60	—	—	—	—	—	—	—	—	—	—	—	—	
Straight	male	DM53740-5001NC	KMX4M11D01	DM53740-1NC	KMX4M12D01	1.70	2.46	3	3.84	18.64	RG 316U	KX22A	50Ω±2	0.50	1.50	2.50	9.50	5.95	1.60	2.05		
	female	DM53742-5001NC	KMX4F11D01	DM53742-1NC	KMX4F12D01	—	—	—	23.60	—	—	—	—	—	—	—	—	—	—	—	—	
Angled	male	DM53741-5001NC	KMX4M11C01	DM53741-1NC	KMX4M12C01	—	—	—	18.64	15.30	—	—	—	—	—	—	9.50	5.95	1.60	—		
	female	DM53743-5001NC	KMX4F11C01	DM53743-3NC	KMX4F12C01	—	—	—	18.64	12.50	—	—	—	—	—	—	—	—	—	—	—	

Specific coaxial contacts

Contact type	Part numbers				Contacts dimension						Cable						Wire					
	Soldered screen	NFC 93569 KMX4	Crimped screen	NFC 93569 KMX4	A ^{+0.10}	B ^{+0.15}	C ^{+0.2}	D ^{+0.15}	E ^{+0.04}	F ^{+0.04}	MILC 17E	NFC 93550	Impe- dance	G	H	I	J	K	L	M (Max.)		
Straight	male	DM63740-5002NC	—	DM63740-3NC	—	—	—	5.95	26.30	—	RG 180BU	—	95Ω±2	0.30	2.60	3.58	9.70	7.90	2	3.14		
	female	DM63742-5002NC	—	DM63742-3NC	—	—	—	—	26.30	—	—	—	—	—	—	—	—	—	—	—	—	
Straight	male	DM63740-5005NC	—	DM63740-5NC	—	—	—	—	23.60	—	—	—	—	—	—	—	9.50	7.9	2	3.81		
	female	DM63742-5004NC	—	DM63742-5NC	—	—	—	5.95	23.60	—	RG 58CU	KX15	50Ω±2	0.90	2.95	4.95	10.70	—	2.40	—	—	
Angled	female	DM63743-5004NC	—	DM63743-6NC	—	—	—	—	18.64	17.50	—	—	—	—	—	—	—	—	—	—	—	

Accessories

D SUB connectors are preferred when input, output connectors are needed for interface functions between equipment-terminals, equipment-network...

In these applications they may be submitted to mechanical stresses, sometimes severe:

- risk of unprotected contact abuse,
- risk of accidental disconnection,
- risk of damage to cable.

To which interference from electromagnetic radiation should be added.

In order to prevent such damage, FCI offers a wide range of accessories and varied combinations suitable for various configurations: hoods with strain relief cable clamps to reinforce connection and cables, locks to prevent accidental separation, EMI-RFI shielded hoods, protective caps, etc...



Plastic hood

1. "Snap together" plastic hood

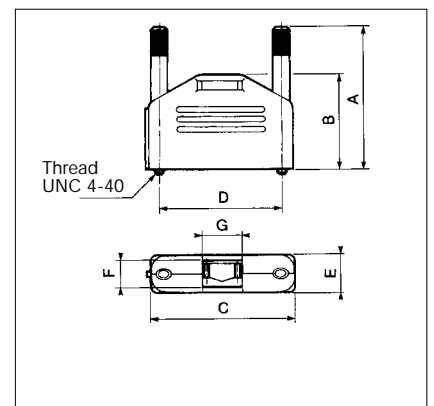

Shell size	Part numbers black hood	A	B	C	D	E	With clamp			Without clamp	
							F		G	F	G
							min.	Max.			
E	8630 3637A	37.25	27.10	34.95	24.99	15.30	1.9	9	6	11.50	8.00
A	8630 3638A	37.25	30.10	43.30	33.32	15.30	1.9	9	6	11.50	8.00
B	8630 3639A	47.25	37.80	57.10	47.04	15.30	2.6	9	13.5	11.50	16.00
C	8630 3640A	47.25	37.80	73.55	63.50	15.30	2.6	9	13.5	11.50	16.00
D	8630 3641A	47.25	37.80	71.20	61.11	17.80	4.4	11.5	15.5	14.00	18.00

Material:
Thermoplastic

Temperature range:
-55°C to +85°C

Packaging:
Box of 50 individual sets

Accessories

2. Universal plastic hood with metal clamp for strain relief

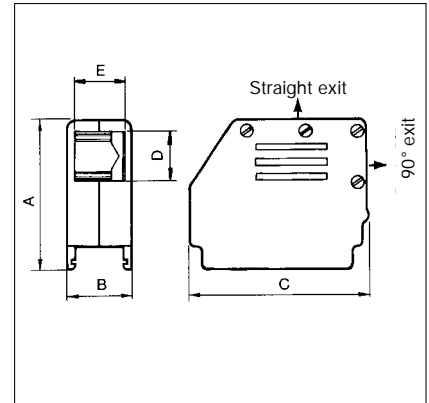

Shell size	Part numbers black hood	Part numbers metalised hood	A	B	C	With clamp			Without clamp	
						D	E		D	E
							min.	Max.		
E	8630 93C 09A	8630 93C 09M	29.75	15.50	24.25	6	1.90	10.10	8	11.50
A	8630 93C 15A	8630 93C 15M	29.75	15.50	32.50	6	1.90	10.10	8	11.50
B	8630 93C 25A	8630 93C 25M	46.50	15.50	46.00	13.50	2.60	10.10	16	11.50
C	8630 93C 37A	8630 93C 37M	46.50	15.50	60.50	13.50	2.60	10.10	16	11.50
D	8630 93C 50A	8630 93C 50M	48.50	18.00	56.50	15.50	4.40	12.60	18	14.00

Material:

black hood: self extinguishing UL rated 94 V0 thermoplastic
metalised hood: thermoplastic

Temperature range:

-55°C to +105°C

Packaging:

Box of 50 individual sets

Accessories

Monobloc plastic hoods for potting

3. Straight exit

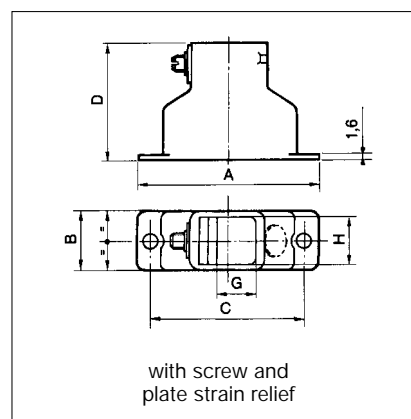
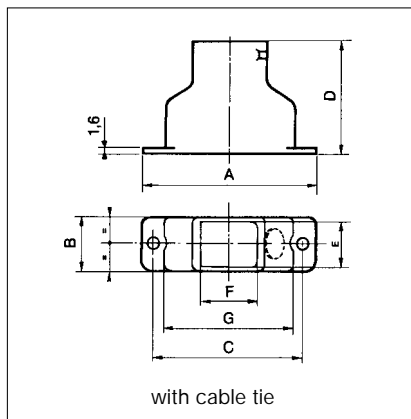

Shell size	Part numbers		A	B	C	D	E	F	G min.	G Max.	H
	Hood with cable tie	Hood with screw and plate									
E	8630-86 B	8630-3920 A	30.60	12.50	25.00	29.00	9.90	9.90	2.70	7.10	10.50
A	8630-21 B	8630-3921 A	38.90	12.50	33.32	29.00	9.90	11.90	4.50	9.10	10.50
B	8630-22 B	8630-3922 A	52.80	12.50	47.05	35.00	9.90	16.40	9.20	13.60	10.50
C	8630-23 B	8630-3923 A	69.10	12.50	63.50	41.00	9.90	23.40	9.20	20.60	10.50
D	8630-24 B	8630-3924 A	66.70	15.30	61.10	41.00	12.70	23.40	9.20	20.60	13.30

Material: self extinguishing UL rated 94 V.O thermoplastic

Temperature range:
-55°C to +105°C

Colour: black

Packaging: per 100 pieces

4. Right angle exit

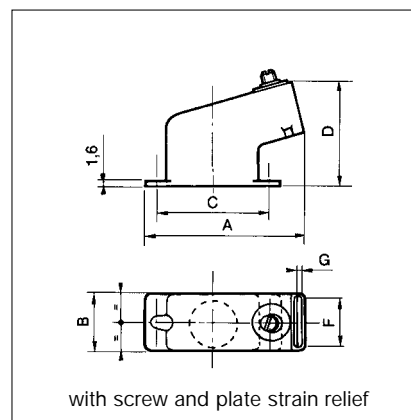
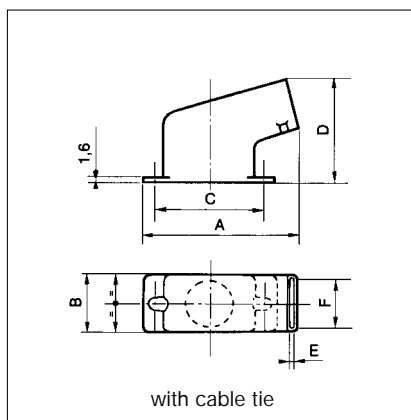

Shell size	Part numbers		A	B	C	D	E	F	G min.	G Max.
	Hood with cable tie	Hood with screw and plate								
E	8630-5002 B	8630-3925 A	30.60	12.50	25.00	26.20	10.50	10.50	2.70	7.10
A	8630-26 B	8630-3926 A	38.90	12.50	33.32	28.60	12.50	10.50	4.50	9.10
B	8630-27 B	8630-3927 A	52.80	12.50	47.05	36.40	17.00	10.50	9.20	13.60
C	8630-28 B	8630-3928 A	69.10	12.50	63.50	42.60	24.00	10.50	9.20	20.60
D	8630-29 B	8630-3929 A	66.70	15.30	61.10	41.60	24.00	13.30	9.20	20.60

Material: self extinguishing UL rated 94 V.O thermoplastic

Temperature range:
-55°C to +105°C

Colour: black

Packaging: per 100 pieces

Accessories

5. Metal hoods with two metal clamps for cable EMI/RFI

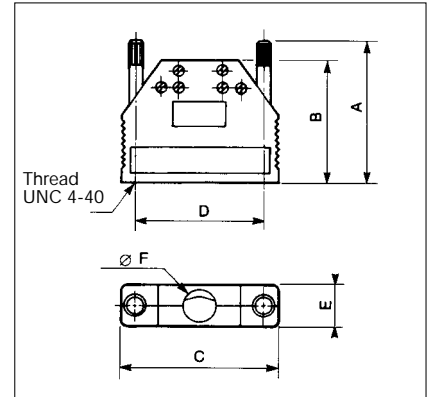
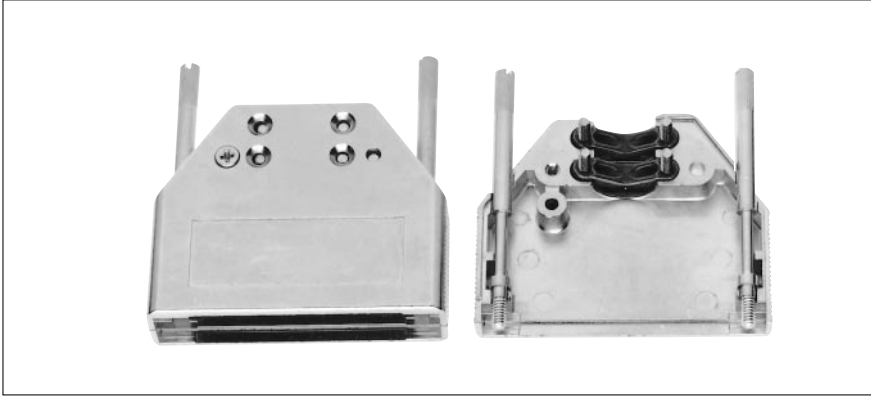

Packaging code **01** in bulk

Shell size	Part numbers	A ^{±0.1}	B ^{±0.3}	C ^{±0.1}	D ^{±0.1}	E ^{±0.2}	F Max.
E	8655 MH 09 01	55.00	45.00	34.40	24.99	14.70	7.85
A	8655 MH 15 01	55.00	45.00	42.70	33.32	14.70	11.80
B	8655 MH 25 01	55.00	45.00	56.70	47.04	14.70	11.80
C	8655 MH 37 01	55.00	45.00	72.95	63.50	14.70	11.80
D	8655 MH 50 01	55.00	45.00	70.60	61.11	17.30	14.10

Material: zamack

Corrosion resistance:
50 hours exposure to salt spray

Plating: nickel

Shell size	E	A	B	C	D
Packaging	80	80	60	40	40

Packaging code **11**: individual set

Shell size	Part numbers	A ^{±0.1}	B ^{±0.3}	C ^{±0.1}	D ^{±0.1}	E ^{±0.2}	F Max.
E	8655 MH 09 11	55.00	45.00	34.40	24.99	14.70	7.85
A	8655 MH 15 11	55.00	45.00	42.70	33.32	14.70	11.80
B	8655 MH 25 11	55.00	45.00	56.70	47.04	14.70	11.80
C	8655 MH 37 11	55.00	45.00	72.95	63.50	14.70	11.80
D	8655 MH 50 11	55.00	45.00	70.60	61.11	17.30	14.10

Shell size	E	A	B	C	D
Packaging	50	50	50	50	50

Accessories

Locking devices

6. Female screw locks

Part numbers	Thread	L Max.	F	Material
8630 01 T	M3	8.30	6.90	BRASS
8655 2153 T	M3	8.30	6.90	STEEL
8630 01 017 T	M3	6.30	5.00	BRASS
8630 01 061 T	M3	13.00	12.00	BRASS
8630 01 060 T	UNC 4.40	8.30	6.90	BRASS

Plating:
tinlead

Corrosion resistance:
50 hours exposure to salt spray

Packaging: per 100 pieces

It is possible to obtain these screw locks in packs of different quantities, as well as locks supplied separately: consult us

Compensating washer thickness:
0.8 mm

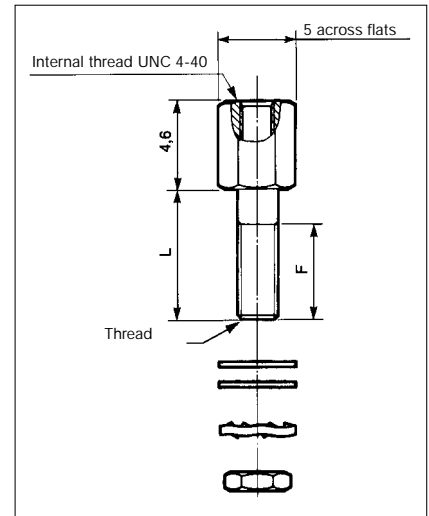

6.1 Specific female screw locks for Delta D series

Part numbers	Thread	L Max.	F	Material
8630 01 018 T	M3	4.5	3.7	Steel
8630 01 019 T	UNC 4.40	4.5	3.7	Steel

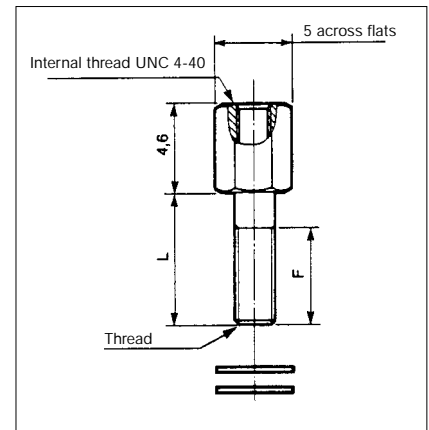

6.2 Torque force

Material	Torque Max. (Nm)
Brass	0,5
Steel	0,7

7. Male screw locks

Shell size	Connector type	For use with connector without hood or with hood 2		For use with connector with hoods 8		For use with connector with hood 3	
		Part numbers	Part numbers	Part numbers	Part numbers		
E	Male	8630 05 A	8630 04 A	8630 09 A			
	Female						
A	Male						
	Female						
B	Male	8630 08 A	8630 05 A				
	Female						
C	Male	8630 15 A	8630 02 A	8630 25 A			
	Female						
D	Male	8630 03 A					
	Female						

Material: steel

Plating: yellow chromate cadmium

Corrosion resistance:
50 hours exposure to salt spray

Packaging: per 100 pieces

To obtain with tin plating, add suffix "T" to end of part number (ex: 8630 05 AT)

Thread: UNC 4-40



Accessories

Hood with cable clamps

8. Metal hood with circular clamp and straight exit

Material: Steel

Plating: Yellow chromate cadmium

Corrosion resistance:
50 hours exposure to salt spray

Packaging: per 100 pieces

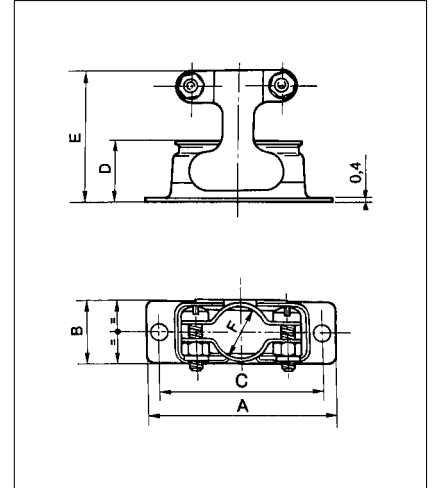

Shell size	Part numbers	A	B	C	D	E	F
E	8630-10	30.55	12.70	24.99	12.30	26.40	8.00
A	8630-11	38.89	12.70	33.32	12.30	26.40	10.00
B	8630-12	52.78	12.70	47.04	12.30	27.20	15.00
C	8630-13	69.06	12.70	63.50	12.30	27.20	18.00
D	8630-14	66.67	15.40	61.17	12.30	27.20	20.60

9. Metal hood with circular clamp and 30° exit

Material: Steel

Plating: Yellow chromate cadmium

Corrosion resistance:
50 hours exposure to salt spray

Packaging: per 100 pieces

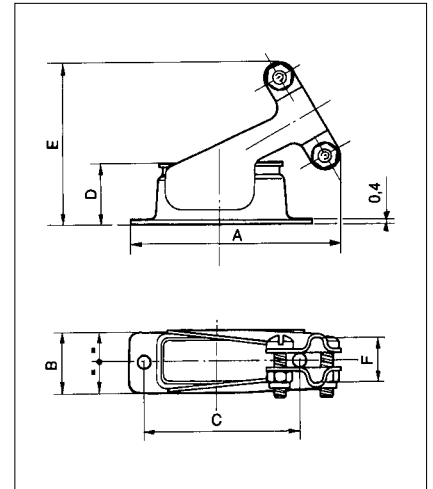

Shell size	Part numbers	A	B	C	D	E	F
E	8630-16	39.00	12.70	24.99	12.30	30.60	8.00
A	8630-17	43.10	12.70	32.32	12.30	32.50	10.00
B	8630-18	55.40	12.70	47.04	12.30	34.50	15.05
C	8630-19	75.30	12.70	63.50	12.30	37.50	18.00
D	8630-20	72.80	15.40	61.11	12.30	37.60	20.60

Accessories

10. Slide locks (reinforced plate)

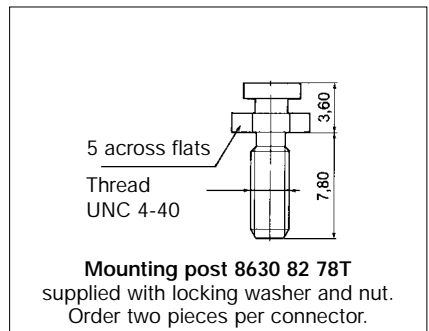
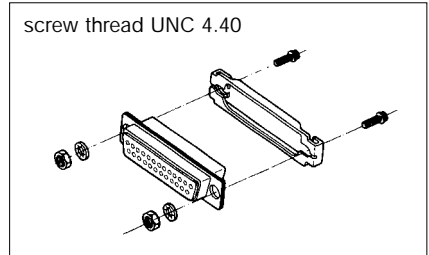
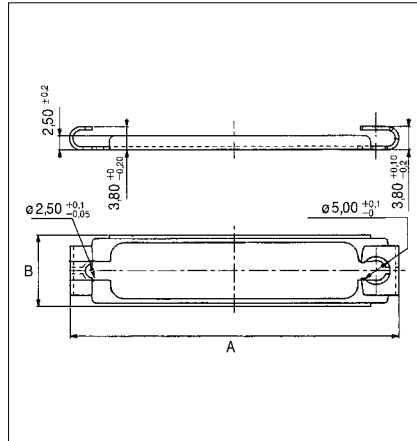

Shell size	Part numbers standard plate	Part numbers plate with short screws for mounting on straight spill connector with harpoon	A ± 0.25	B + 0.05 / - 0.40
E	8630-77A	8655-2163	35.70	12.50
A	8630-78A	8655-2164	44	12.50
B	8630-79A	8655-2165	57.75	12.50
C	8630-80A	8655-2166	74.25	12.50
D	8630-81A	8655-2167	71.85	15.00

Material: steel

Plating: tin

Packaging: per 100 pieces

11. Lever locks

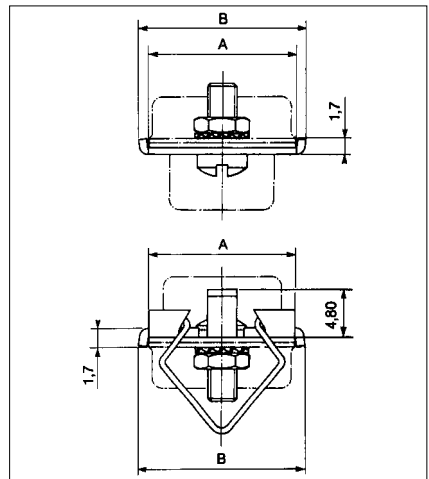
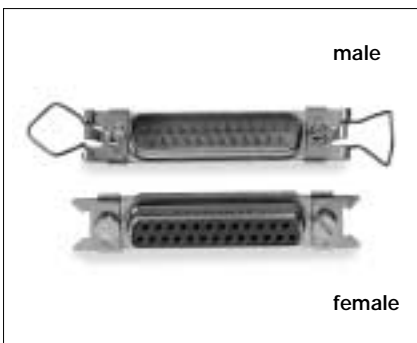

Shell size	A	B	M3 thread		UNC 4.40 thread	
			Female	Male	Female	Male
E, A, B, C	12.50	14.30	8630-3425	8655-2096	8630-3425-060	8655-2098
D	15.30	17.10	8630-3426	8655-2097	8630-3426-060	8655-2099

Material: steel

Plating: passivated

Packaging: per 100 pieces

12. Specific lever locks for straight Delta D serie with harpoons

Shell size	M3 thread		UNC 4.40 thread	
	Female	Male	Female	Male
E, A, B, C	8630-3425	8655-20961A	8630-3425-060	8655-20981A
D	8630-3426	8655-20971A	8630-3426-060	8655-20991A

Accessories

13. Metal caps

Shell size	For use with connectors	Part numbers	Packaging
E	Male	8655-3148	30
	Female	8655-3113	30
		8655-3138*	30
A	Male	8655-3149	25
	Female	8655-3114	25
		8655-3139*	25
B	Male	8655-3150	20
	Female	8655-3115	20
		8655-3140*	20
C	Male	8655-3151	15
	Female	8655-3116	15
		8655-3141*	15
D	Male	8655-3152	10
	Female	8655-3117	10
		8655-3142*	10



Material: steel

Plating: cadmium

To obtain with tin plating, add suffix "T" to end of part number.

* Sealed caps IP 65

14. Attaching cord for metal caps

8655.3156 (length = 100 mm)

Packaging: individual



15. Plastic dust cap



Shell size	For male connector	A	B	For female connector	A	B
E	70508	19.17	10.30	70513	17.77	9.00
A	70509	27.50	10.30	70514	26.10	9.00
B	70510	41.67	10.70	70515	39.82	9.00
C	70511	58.13	10.70	70516	56.28	9.00
D	70512	55.49	13.40	70517	53.89	11.85

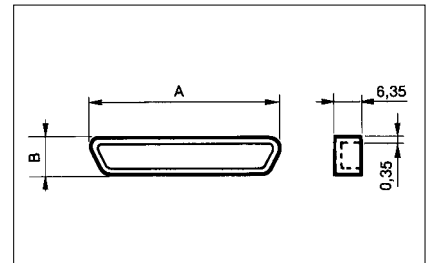

Material: thermoplastic

Color: red

Packaging: per 100 pieces

Accessories

Brackets

Plastic mounting brackets are normally supplied with angled spill D.SUB connectors series D, DP, DM and DMW.

However, both plastic and metal brackets can be ordered separately, using the part numbers listed below. These brackets are supplied with a screw and a nut. Order two assemblies for each connector.

16. Plastic brackets

Shell size	Part numbers	A	B	C	D
E, A, B, C	8630 3714	13.20	7.20	10.74	13.90
D	8630 3715	16.00	8.60	12.09	16.50

Material: UL rated 94 V.O thermoplastic

Packaging: per 100 pieces

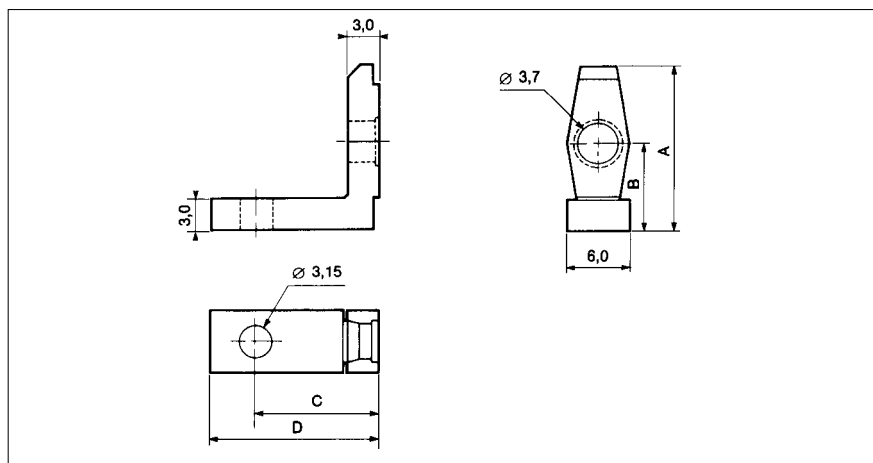

17. Plastic brackets with oblong mounting hole to PCB

Shell size	Part numbers	A	B	C	D	E
E, A, B, C	8630 3612	13.20	7.40	13.60	10.50	0.8
D	8630 3613	16.15	8.80	16.50	11.60	1.0

Material: UL 94 V.O rated thermoplastic

Packaging: per 100 pieces

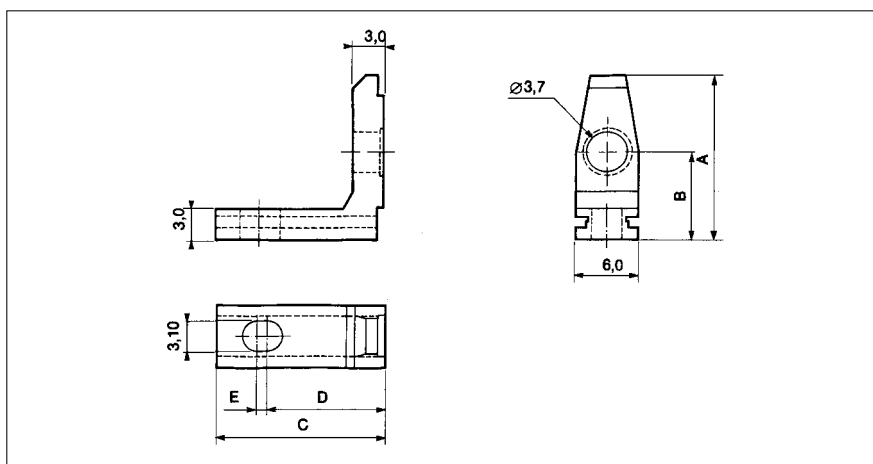

18. Metal brackets

Shell size	Part numbers	A	B	C	D
E, A, B, C	8655 2008	10.55	7.20	10.74	13.90
D	8655 2009	12.55	8.60	12.09	16.50

Material: steel

Plating: cadmium

To obtain with tin plating, add suffix "T" to end of part number

Packaging: per 100 pieces

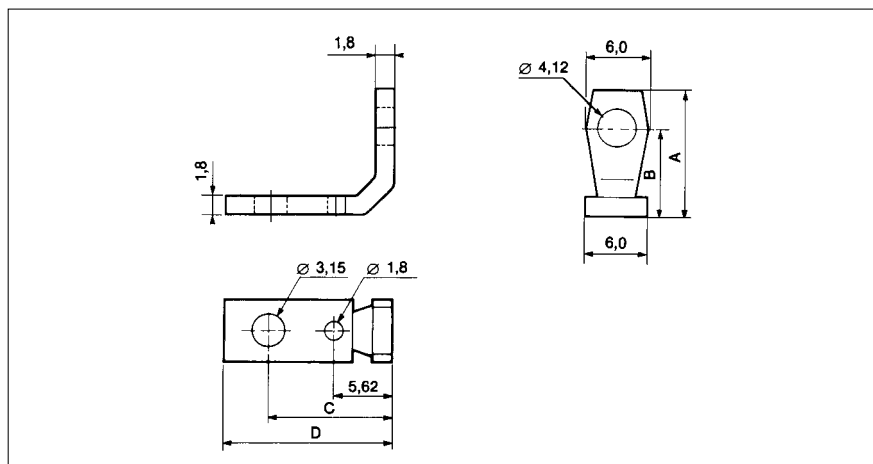

D-Sub

Panel cut-out

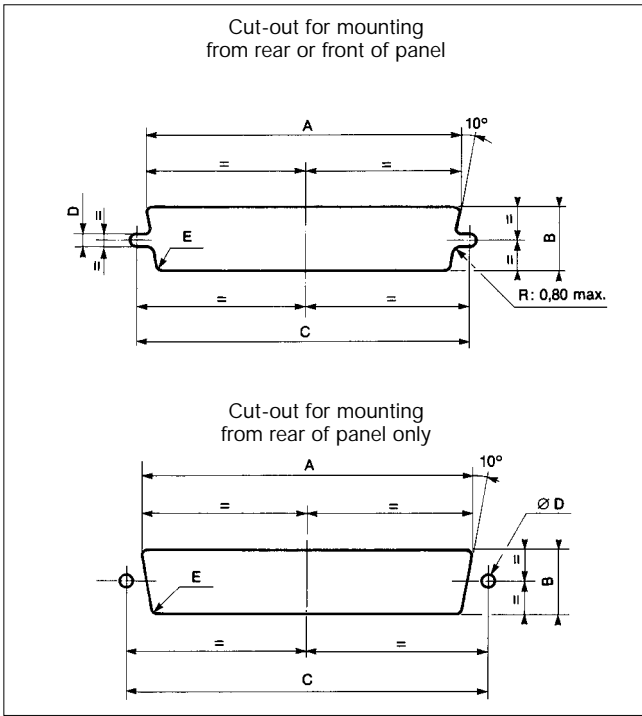

Shell size	Type of mounting	Mounting position	A ^{±0.2}	B ^{±0.2}	C ^{±0.2}	D ^{±0.01}	E ^{±0.1}
E	rigid	front	22.20	13.00	25.00	3.00	2.10
		rear	20.50	11.40	25.00	3.00	3.30
	float	front	23.00	13.80	25.00	2.20	2.10
		rear	21.30	12.20	25.00	2.20	3.30
A	rigid	front	30.50	13.00	33.30	3.00	2.10
		rear	28.80	11.40	33.30	3.00	3.30
	float	front	31.30	13.80	33.30	2.20	2.10
		rear	29.60	12.20	33.30	2.20	3.30
B	rigid	front	44.30	13.00	47.00	3.00	2.10
		rear	42.50	11.40	47.00	3.00	3.30
	float	front	45.10	13.80	47.00	2.20	2.10
		rear	43.30	12.20	47.00	2.20	3.30
C	rigid	front	60.70	13.00	63.50	3.00	2.10
		rear	59.10	11.40	63.50	3.00	3.30
	float	front	61.50	13.80	63.50	2.20	2.10
		rear	59.80	12.20	63.50	2.20	3.30
D	rigid	front	58.30	15.80	61.50	3.00	2.10
		rear	56.30	14.10	61.50	3.00	3.30
	float	front	59.20	16.60	61.50	2.20	2.10
		rear	57.20	14.90	61.50	2.20	3.30

Panel mounting

It is recommended that only **one** of a pair of connectors should be float mounted. Rigid mounted connectors require 2 screws Ø 3mm, float mounting connectors require 2 screws Ø 2 mm.

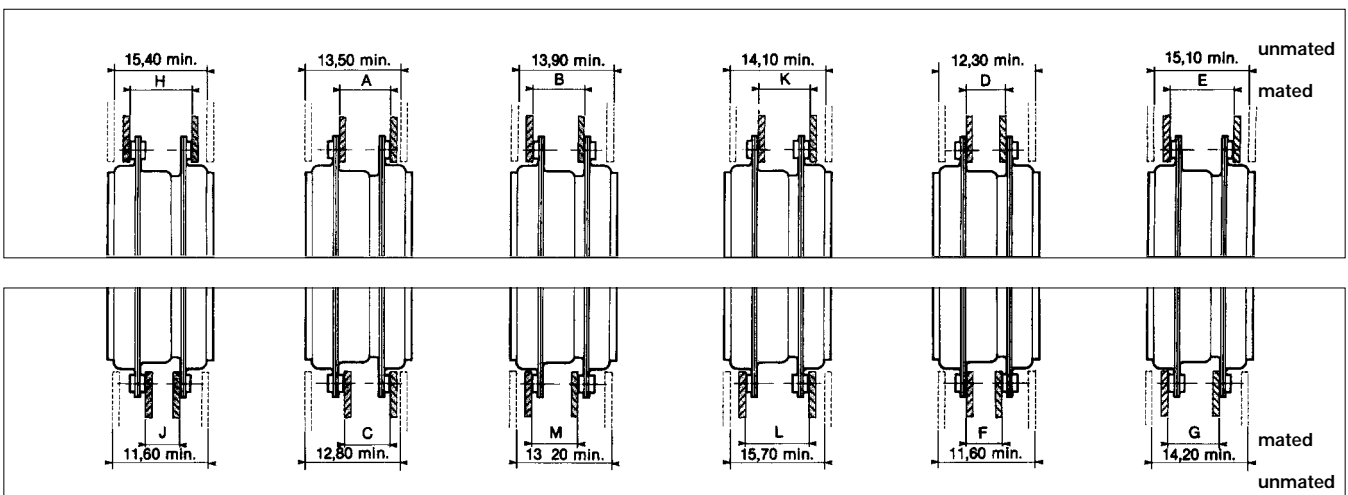

Shell size	A ^{+0.6} ₋₀	B ^{+0.6} ₋₀	C ^{+0.6} ₋₀	D ^{+0.6} ₋₀	E ^{+0.6} ₋₀	F ^{+0.6} ₋₀	G ^{+0.6} ₋₀	H ^{+0.6} ₋₀	J ^{+0.6} ₋₀	K ^{+0.6} ₋₀	L ^{+0.6} ₋₀	M ^{+0.6} ₋₀
E	7.65	7.65	6.85	6.45	8.85	5.65	8.25	9.45	5.65	8.25	9.45	6.85
A	7.65	7.65	6.85	6.45	8.85	5.65	8.25	9.45	5.65	8.25	9.45	6.85
B	7.55	7.55	6.75	6.35	8.85	5.55	8.15	9.35	5.55	8.15	9.35	6.75
C	7.55	7.95	6.75	6.35	9.15	5.55	8.35	9.55	5.55	8.15	9.75	7.15
D	7.55	7.95	6.75	6.35	9.15	5.55	8.35	9.55	5.55	8.15	9.75	7.15

D-Sub

Shell dimensions

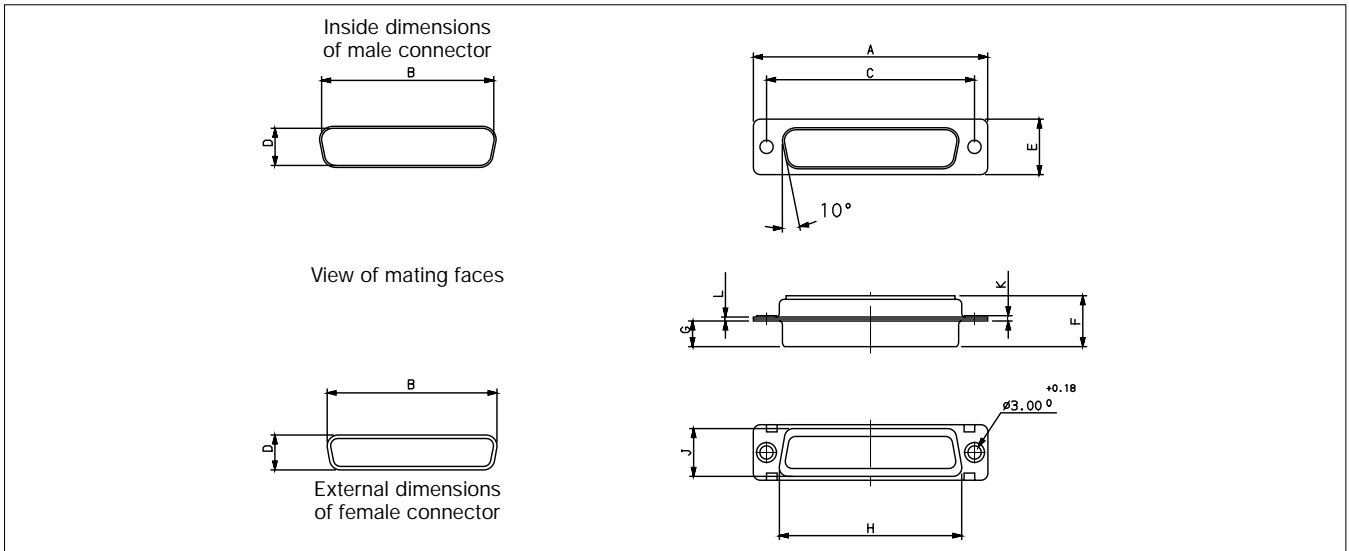

		A ± 0.38	B ± 0.13	C ± 0.13	D ± 0.13	E ± 0.38	F Max.	G $\begin{smallmatrix} +0.25 \\ -0 \end{smallmatrix}$	H ± 0.25	J ± 0.25	K Max.	L ± 0.12
E	P	30.81	16.91	24.99	8.35	12.55	10.99	5.85	19.27	10.71	1.50	0.90
	S	30.81	16.33	24.99	7.89	12.55	11.21	6.05	19.27	10.71	1.50	0.90
A	P	39.14	25.24	33.32	8.35	12.55	10.99	5.85	27.50	10.71	1.50	0.90
	S	39.14	24.66	33.32	7.89	12.55	11.21	6.05	27.50	10.71	1.50	0.90
B	P	53.03	38.96	47.04	8.35	12.55	11.07	5.75	41.27	10.71	1.50	0.90
	S	53.03	38.37	47.04	7.89	12.55	11.21	6.05	41.27	10.71	1.50	0.90
C	P	69.32	55.42	63.50	8.35	12.55	11.09	5.75	57.70	10.71	1.50	1.00
	S	69.32	54.83	63.50	7.89	12.55	11.21	6.05	57.70	10.71	1.50	0.90
D	P	66.93	52.80	61.11	11.20	15.37	11.09	5.75	55.32	13.56	1.70	1.00
	S	66.93	52.42	61.11	10.74	15.37	11.21	6.05	55.32	13.56	1.50	0.90

PC card drilling dimensions (mm) Note: $\varnothing A = 0.8$ min. for D, DP
 (for solder versions) Note: $\varnothing A = 0.9$ min. for Delta D, Compact D, HE501, HE507, HE508 and DP US footprint

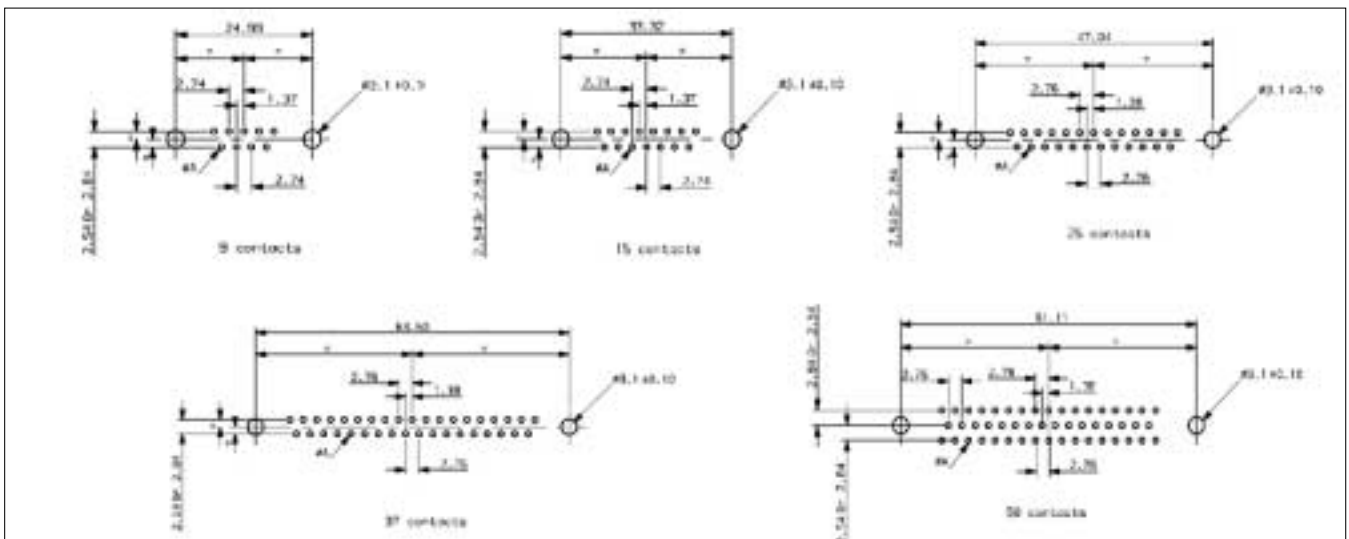

Note: pitch between row = 2.84 for straight spills

D-Sub

Layouts

Male insulator front view

Contacts are individually numbered on both sides of the insulator.

Standard connectors

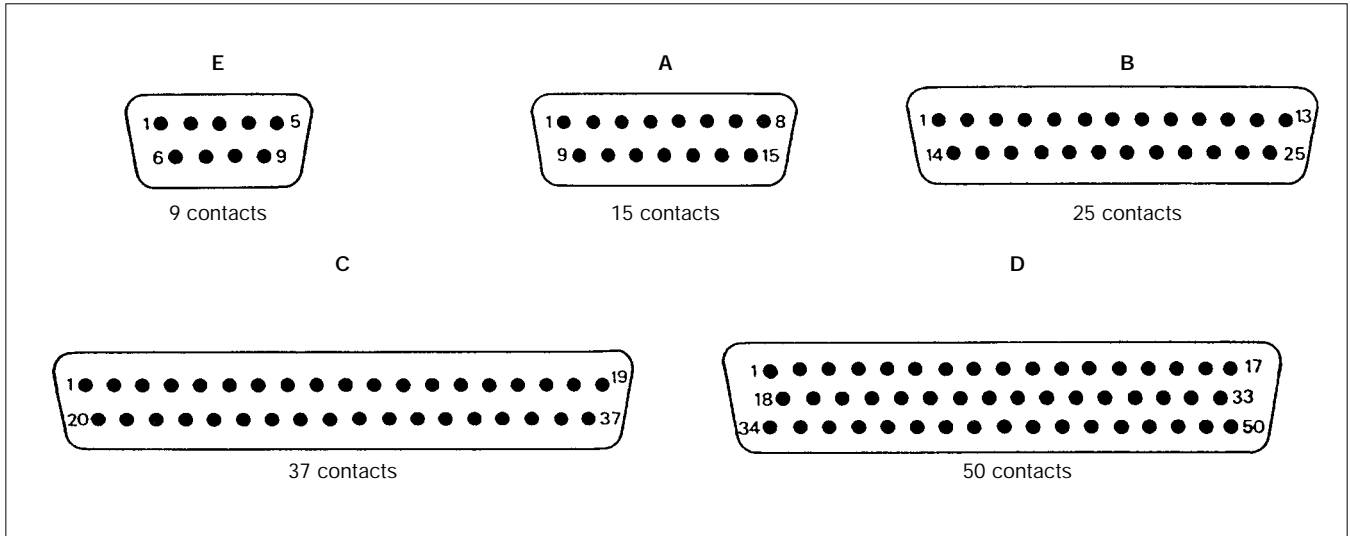

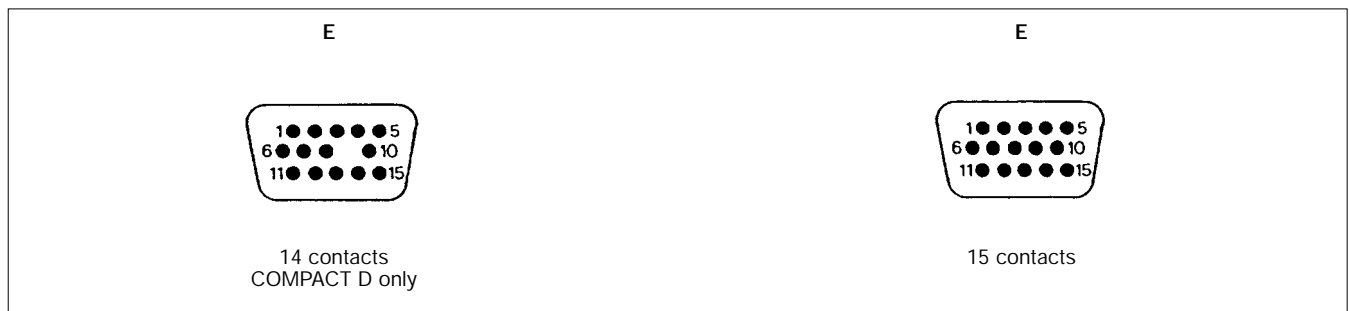

High density connectors (COMPACT D)





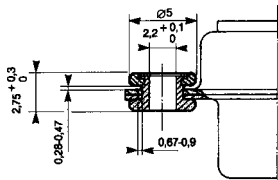

D-Sub

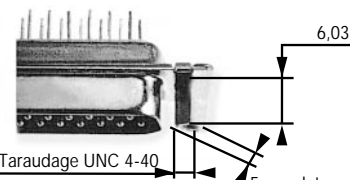
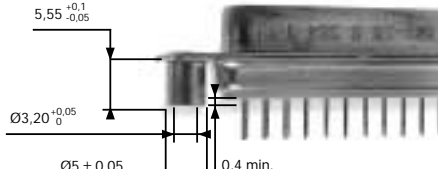
Mounting options for D, DP, DW, DM, DMW, 8656, 8657 series (dimensions in mm)

Options 1

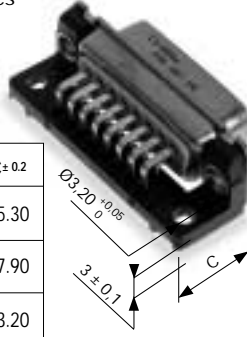
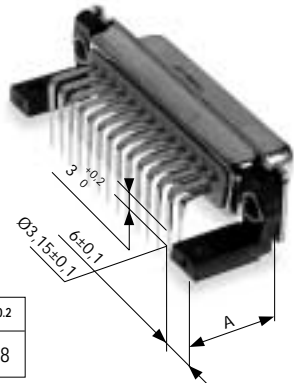
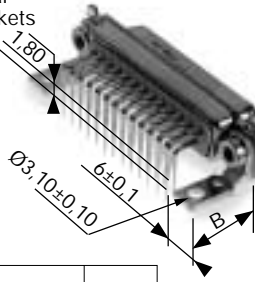

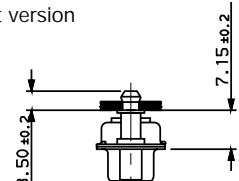
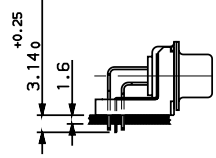
<p>F Float mounting (only military series)</p> 	<p>L Clinch nut M3 O Clinch nut UNC 4-40</p> 
<p>V Female screw lock UNC 4-40</p> 	<p>S Spacers riveted to shell</p> 

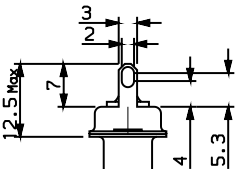
Options 2

<p>C Without bracket</p> 	<p>Blank For DM and DMW series connectors are delivered with monobloc plastic bracket For DW series</p>  <table border="1" data-bbox="502 1220 742 1489"> <thead> <tr> <th>Termination</th> <th></th> <th>C ± 0.2</th> </tr> </thead> <tbody> <tr> <td rowspan="2">5</td> <td>9 to 37 contacts</td> <td>15.30</td> </tr> <tr> <td>50 contacts</td> <td>17.90</td> </tr> <tr> <td rowspan="2">9 (US standart)</td> <td>9 to 37 contacts</td> <td>13.20</td> </tr> <tr> <td>50 contacts</td> <td>15.70</td> </tr> </tbody> </table> <p>Bracket thickness = 3 ± 0.1</p>	Termination		C ± 0.2	5	9 to 37 contacts	15.30	50 contacts	17.90	9 (US standart)	9 to 37 contacts	13.20	50 contacts	15.70	<p>Blank For DP series connectors are delivered with 2 separate plastic brackets (except for layout 50 with monobloc bracket)</p>  <table border="1" data-bbox="989 1400 1141 1489"> <thead> <tr> <th>Layout</th> <th>A ± 0.2</th> </tr> </thead> <tbody> <tr> <td>9 to 37 contacts</td> <td>14.8</td> </tr> </tbody> </table>	Layout	A ± 0.2	9 to 37 contacts	14.8
Termination		C ± 0.2																	
5	9 to 37 contacts	15.30																	
	50 contacts	17.90																	
9 (US standart)	9 to 37 contacts	13.20																	
	50 contacts	15.70																	
Layout	A ± 0.2																		
9 to 37 contacts	14.8																		
<p>M Metal brackets</p>  <table border="1" data-bbox="135 1624 375 1892"> <thead> <tr> <th>Termination</th> <th></th> <th>B ± 0.2</th> </tr> </thead> <tbody> <tr> <td rowspan="2">5, 8, 14, 18</td> <td>9 to 37 contacts</td> <td>14.80</td> </tr> <tr> <td>50 contacts</td> <td>17.40</td> </tr> <tr> <td rowspan="2">9 (US standart)</td> <td>9 to 37 contacts</td> <td>13.19</td> </tr> <tr> <td>50 contacts</td> <td>15.99</td> </tr> </tbody> </table>	Termination		B ± 0.2	5, 8, 14, 18	9 to 37 contacts	14.80	50 contacts	17.40	9 (US standart)	9 to 37 contacts	13.19	50 contacts	15.99	<p>U Monobloc plastic bracket with metal plate for electrical continuity (dim. same as above)</p> 	<p>G Harpoon with electrical continuity For DM and DP series available in angled version only For PCB thickness of 1.6 Metallized hole Ø 3.1 ± 0.12</p> <p>straight version</p>  <p>angled version</p>  <p>except 50 way</p>				
Termination		B ± 0.2																	
5, 8, 14, 18	9 to 37 contacts	14.80																	
	50 contacts	17.40																	
9 (US standart)	9 to 37 contacts	13.19																	
	50 contacts	15.99																	
<p>H Shielding fingers for solder D series (not available on 50 way)</p> 																			

D-Sub

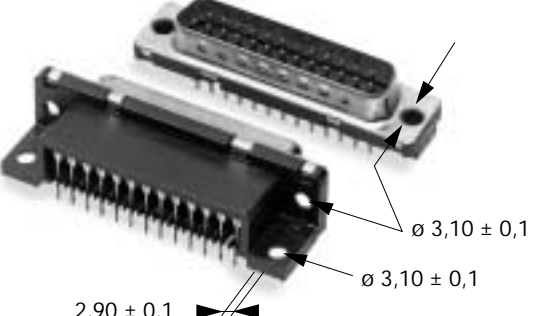
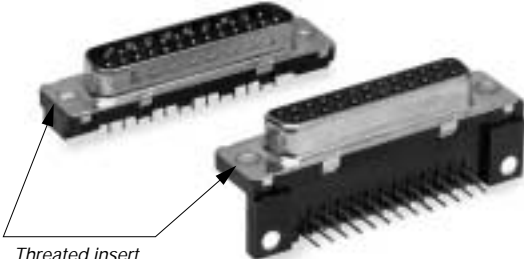
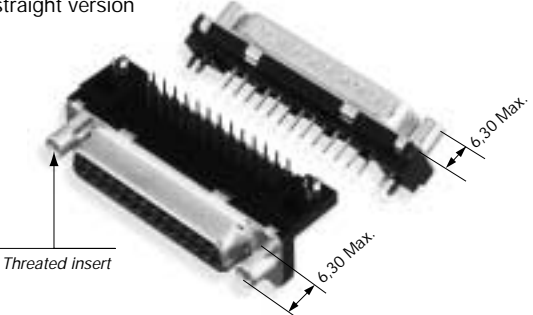
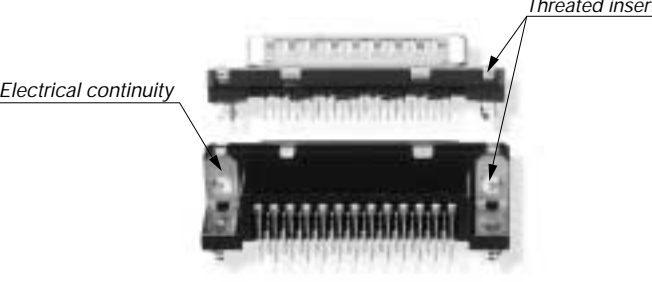
Mounting options for DELTA D and COMPACT D series

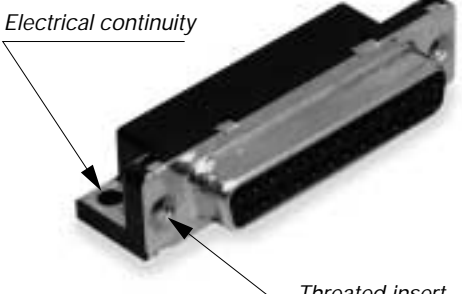
<p>PA Standard hole without hardware</p>  <p>$2,90 \pm 0,1$</p> <p>$\varnothing 3,10 \pm 0,1$</p> <p>$\varnothing 3,10 \pm 0,1$</p>	<p>PL With threaded insert M3 PX With threaded insert UNC 4-40 PV With female screw UNC 4-40 (not represented)</p>  <p>Threaded insert</p>
<p>GV Harpoons + female screw UNC 4-40 + electrical continuity through metal strip for angled version and monobloc hardware for straight version GI Harpoons + female screw M3 + electrical continuity through metal strip for angled version and monobloc hardware for straight version</p>  <p>Threaded insert</p> <p>6,30 Max.</p> <p>6,30 Max.</p>	<p>GL Thread M3 GX Thread UNC 4-40 Harpoons + insert+ electrical continuity through metal strip for angled version and monobloc hardware for straight version</p>  <p>Threaded insert</p> <p>Electrical continuity</p> <p>PCB thickness: 1,6 mm/Metallized toles $\varnothing 3,1^{+0,1}$</p>
<p>UV Female screw UNC 4-40 + electrical continuity through metal strip</p> 	<p>UL Insert M3 + electrical continuity through metal strip UX Insert UNC 4-40 + electrical continuity through metal strip UA Electrical continuity through metal strip</p>  <p>Electrical continuity</p> <p>Threaded insert</p>

FCI reserves the right to make any engineering refinements, alterations or improvements deemed necessary on its products. The dimensions appearing in this catalogue are thus subject to change without notice. When dimensions are critical detailed drawings should be requested.