

THIS DRAWING IS UNPUBLISHED. RELEASED FOR PUBLICATION
 © COPYRIGHT - By - ALL RIGHTS RESERVED.

LOC		DIST		REVISIONS			
P	LTR	DESCRIPTION		DATE	DWN	APVD	
	Y	REV PER ECO 14-014240		10-2-14	CT	CT	

WHEN ORDERING CONTACT ON TAPE, ORDER BY THE TAPE NUMBER PLUS THE PACKAGING CODE AS FOLLOWS:

- 2. FOR USE WITH AMP TAPETRONIC, PNEUMATIC TOOL-
A. 1000 PARTS TO A BOX ADD PACKAGING CODE: 1MBOX
- 3. FOR USE WITH 4/8 INDENT STRIPPER CRIMP-
A. 1000 PARTS TO A REEL ADD PACKAGING CODE: 1MREEL
B. 5000 PARTS TO A REEL ADD PACKAGING CODE: 5MREEL

- 1 MATERIAL: COPPER ALLOY PER MIL-C-39029 & MIL-DTL-24308.
- 2 ALL DIMENSIONS APPLY AFTER PLATING.
- 3 ---
- 4 ALL DIAMETERS CONCENTRIC WITH EACH OTHER WITHIN .004 T.I.R.
- 5 PIN MATES WITH SOCKET 205090 (AS 39029/63).
- 6 ALL SURFACES HAVE $\sqrt{63}$ OR BETTER FINISH, UNLESS SHOWN.
- 7 POINT OF PLATING MEASUREMENT .188 [4.78] FROM TIP OF PIN.
- 8 PLATING: GOLD PER ASTM-B-488 (TYPE II) OVER NICKEL PER AMS-QQ-N-290.
- 9 PLATING: GOLD PER ASTM-B-488 (TYPE II) OVER COPPER PER MIL-C-14550, CLASS 4.
- 10 PLATING: GOLD PER ASTM-B-488 (TYPE II, CLASS 0) OVER NICKEL PER AMS-QQ-N-290.
- 11 PLATING:
MATING AREA: GOLD PER ASTM-B-488 (TYPE II) OVER NICKEL PER AMS-QQ-N-290.
NON MATING AREA: GOLD PER ASTM-B-488 OVER NICKEL PER AMS-QQ-N-290.
- 12 MANUFACTURER'S LOGO ("A" OR "- . .") LOCATION OPTIONAL
- 13 CONTACTS QUALIFIED TO AS39029/64-369
- 14 CONTACTS QUALIFIED TO GSFC-S-311-P-4/10, NASA P/N G-10-P1
- 15 RESTRICTED PART NUMBER.

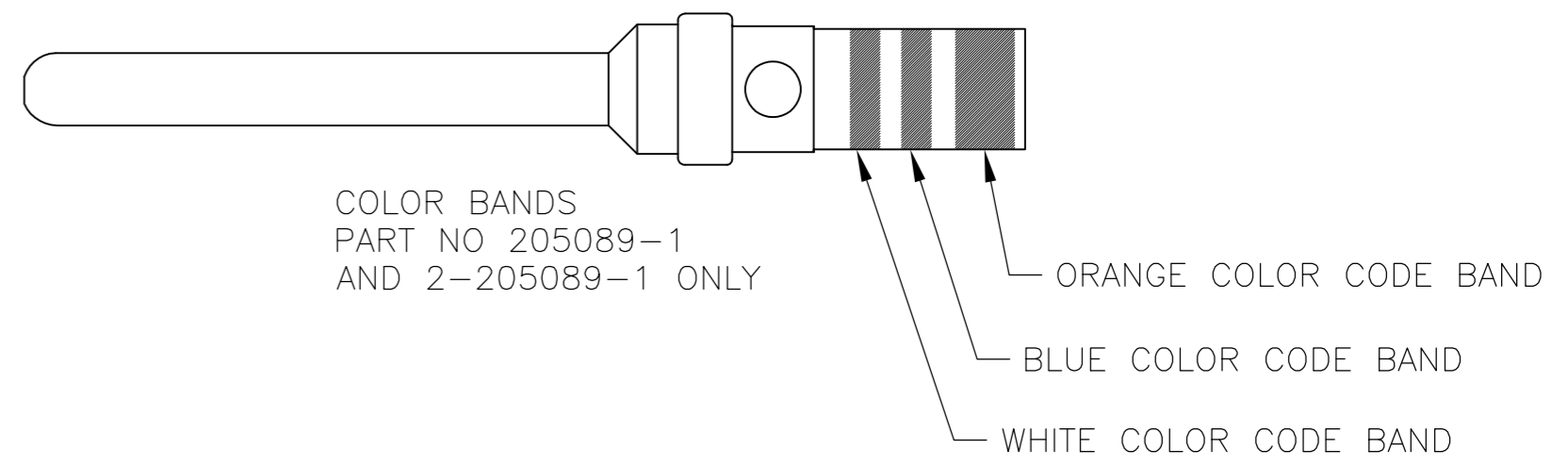
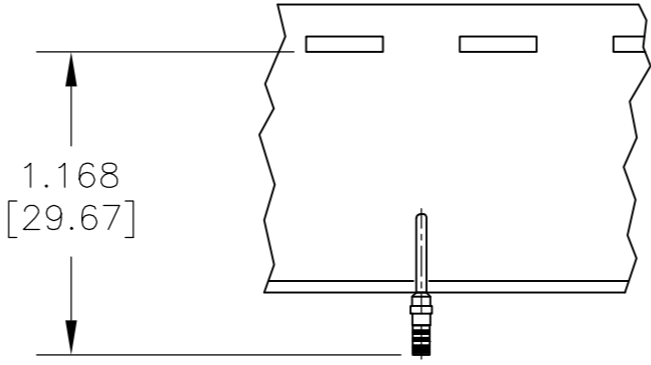
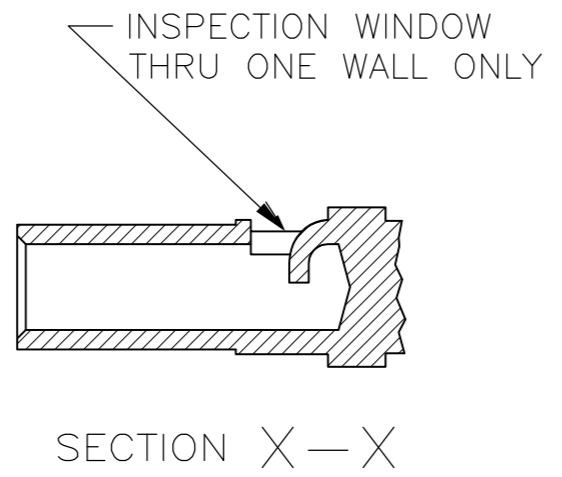
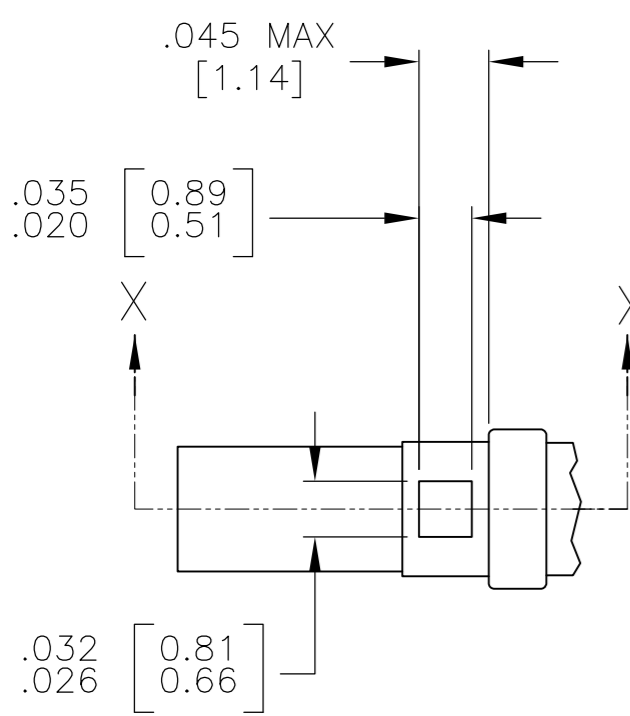
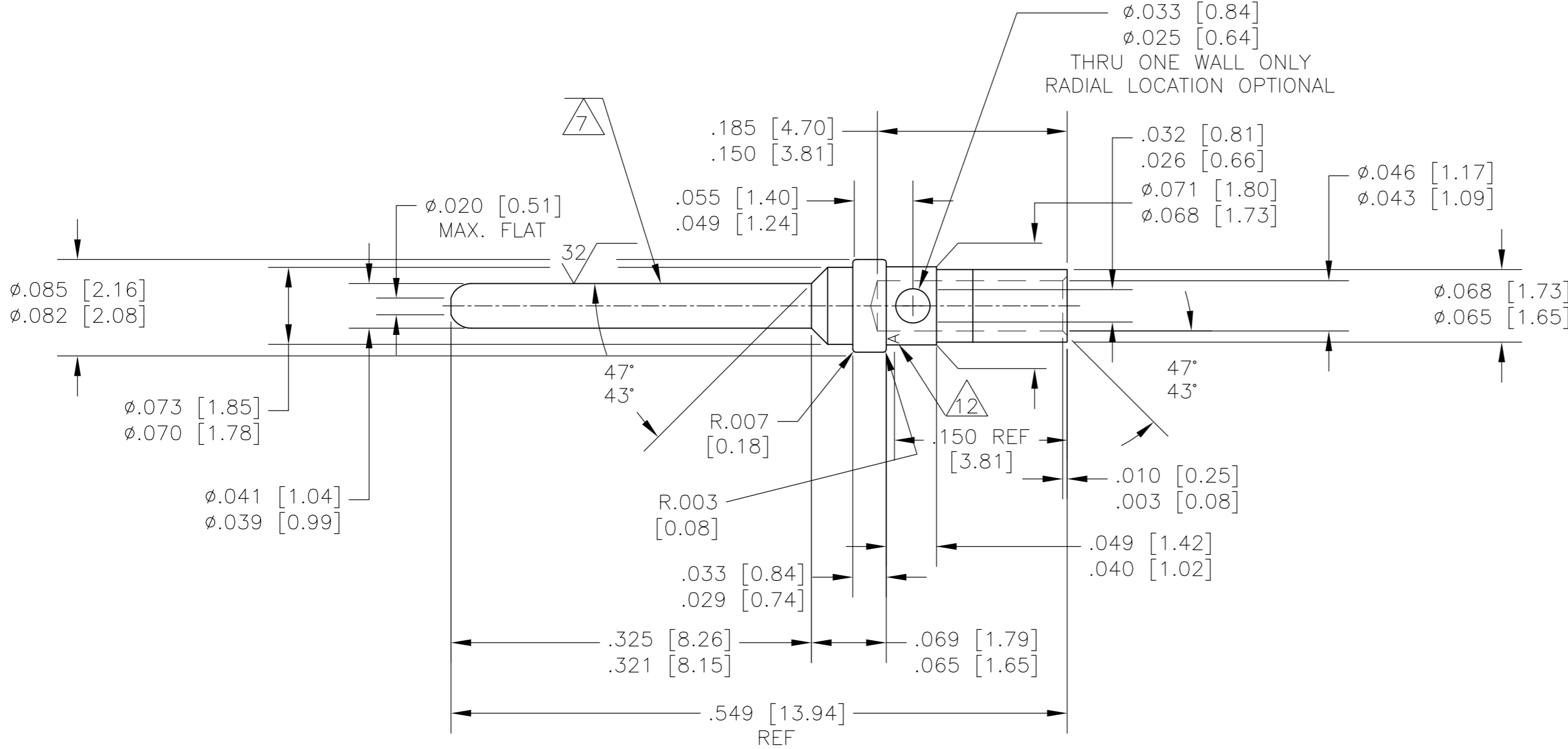

INSPECTION WINDOW OPTIONAL DESIGN $\triangle 16$

$\triangle 15$			2-205089-4
$\triangle 15$			2-205089-1
$\triangle 13$	WITHOUT COLOR CODE	$\triangle 8$	1-205089-1
$\triangle 13$	WITHOUT COLOR CODE	$\triangle 10$	1-205089-0
$\triangle 14$	WITHOUT COLOR CODE	$\triangle 9$	205089-4
$\triangle 13$	CONTACT ON TAPE	SAME AS -1	205089-2
$\triangle 13$	AS SHOWN	$\triangle 11$	205089-1
	DESCRIPTION	PLATING	PART NO.

THIS DRAWING IS A CONTROLLED DOCUMENT.		DWN	25AUG2003		STE TE Connectivity	
		CHK	J. KAISER 10-13-03			
		APVD	D. MILLER 10-13-03		NAME	
		PRODUCT SPEC	-		PIN SIZE 20 CONTACT, AMPLIMITE	
		APPLICATION SPEC	-		SIZE	
		WEIGHT	-		CAGE CODE	DRAWING NO
		MATERIAL	$\triangle 1$		A2 00779	C=205089
		FINISH	-		RESTRICTED TO	
		CUSTOMER DRAWING			SCALE	SHEET
					10:1	1 of 1
					REV	Y