

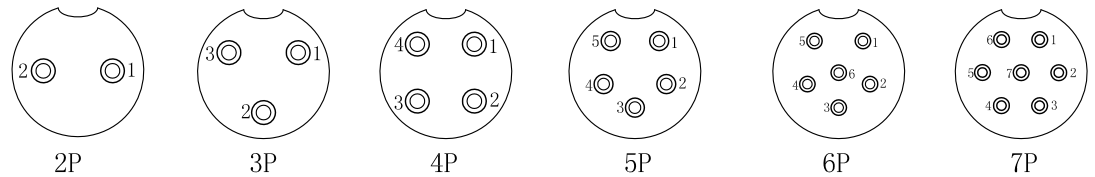

Product NO.		RHT-634-1172			
ISSUE	DESCRIPTION	DWN	DATE	APPROVEN	
First	First issue	Gavin	2018/11/05	JIM. KING	

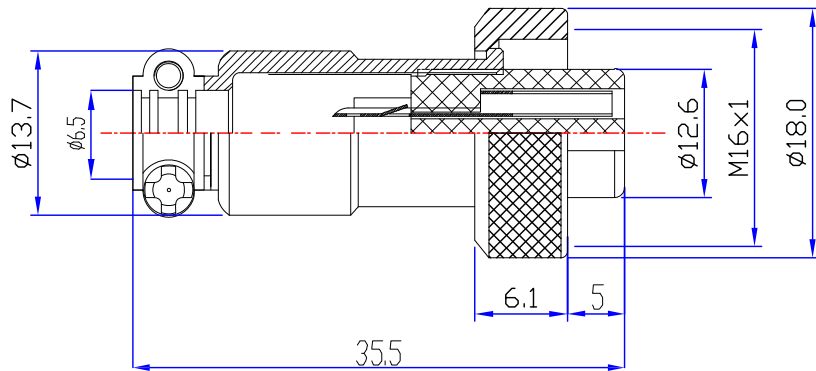

Material and specifications

- Coupling Threaded coupling
- Shell material Zinc alloy with Nickel Plate
- Insert material bakelite
- Contact material copper Silver Plate/Nickel
- Termination Solder
- Mating cycle 500
- Cable diameter -20°C +85°C

Technology parameter						
NO.of contacts	2	3	4	5	6	7
Rated current (A)	7	7	7	7	5	5
Operation limit voltage(AC.V.rms)	220	220	125	125	125	125
Withstanding voltage(AC.V.rms) 1 minute	1500	1500	1500	1500	1500	1500
Insulation resistance (mΩ)	2000	2000	2000	2000	2000	2000
Contact resistance (mΩ)	3	3	3	4	5	5
Solder cup mouth aperture	Ø1.4	Ø1.4	Ø1.4	Ø1.2	Ø0.8	Ø0.8
Solder inter diameter	Ø2.5	Ø2.5	Ø2.5	Ø2.0	Ø1.5	Ø1.5

-TOLERANCES- UNLESS OTHERWISE SPECIFIED	RENHOTEC GROUP www.renhotec.com					
	PART DESCRIPTION: GX16 FEMALE CONNECTOR					
UNLESS OTHERWISE SPECIFIED TOLERANCES FOR MILLIMETERS ARE: 0.5 - 8mm ± 0.20mm 8 - 30mm ± 0.25mm 30 - 120mm ± 0.30mm	Appr: JIM. KING	P/N: RHT-634-1172				
	Check:	Date	Scale	Unit	Type	Page
	Draw: Gavin	2018. 11. 05	Free	MM	Z	1/1