

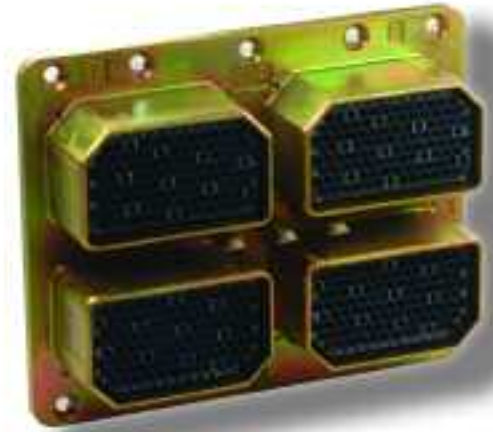

ITT

Electronic Components

**Cannon
Rack & Panel
Connectors**



Engineered for life

Cannon Rack and Panel

ITT Electronic Components is a division of the multi-national ITT Corporation a \$7.5 billion dollar global enterprise. Our connector portfolio remains the most extensive in the industry offering the most reliable and cost effective range of interconnect solutions. These innovations have enabled ITT to provide products and technologies to such markets as:

- Aerospace
- Computers Systems
- Defense Electronics
- Geophysical
- Industrial Automation
- Medical Electronics

When you specify a Cannon Rack and Panel connector, you can rely on a product designed, developed, and manufactured to the highest quality and reliability standards in the industry. This tradition of excellence is based on ITT's corporate culture of operating its entire business under the principles of Six Sigma. At ITT, Six Sigma is not just a quality philosophy but a complete corporate culture that drives the entire business. Our Value Based Management and Value Based Product Development systems are two cornerstones of ITT that allows for the development of both leadership and product development principles, ensuring that the correct industry leading products are developed to the accepted market driven lead times. These principles have allowed ITT to become the market leader in all of our business portfolios.

Six Sigma Manufacturing

ITT operates manufacturing facilities in the United States, France, Germany, Italy, Mexico, China, and the UK, all of which have particular product area strengths allowing ITT to offer a truly global footprint to our customers. Our facilities are world class and accommodate full vertical integration with the latest manufacturing technologies including: automated and robotic machining centers, Super Market manufacturing cells, Kanban pull systems, and automated electrical, mechanical, and optical test and inspection equipment. The combination of our manufacturing strength and our advanced manufacturing facilities allows ITT to offer

products at market driven prices. Our capabilities, especially in robotics, computerized precision tooling, Kaizen Project Management, Six Sigma tools, and test labs, gives ITT the most optimized global manufacturing footprint in the interconnect industry.

The Custom Difference







As the industry leader in harsh environment interconnect applications, ITT's world class engineering teams will work directly with our customers to design and develop cost effective solutions for their applications. In many cases we may modify one of our standard designs to ensure a highly reliable solution where timing is critical. Yet, in those cases where a complete custom interconnect solution is required, ITT will work with our customer's Engineers to design an interconnect solution which will be cost effective yet highly reliable. As professional consultants, our Engineering teams will provide a thorough systems and mechanical analysis of any proposed solution. These analyses provide our customers with sophisticated electrical signal and mechanical characterizations to determine the best solution for their application.

RoHS Compliance Information

ITT has implemented a strict parts control plan for all ITT electronics plants worldwide that allows the Rack and Panel connector product portfolio to meet the requirements of European Union Directive 2002/95/EC better know as the Reduction of Hazardous Substances initiative. To make things easier for our customers, Rack and Panel products can be ordered with an R prefix number which insures our customers will receive RoHS compliant parts for their commercial electronics applications and equipment. Since most RoHS hazardous substances center around specific metal plating and lead solder coatings, ITT's products for RoHS compliance are available in the following plating finishes: electroless nickel, stainless steel, Anodize over aluminum and Gold plating. It should be noted that gold plating would be recommended as the replacement for tin-lead solder when ordering board mount connectors.



Cannon Rack and Panel

	BKAD/E/F ARINC 600	SGA ARINC 600	DPXNE/NA MIL-C-81659	DPX ARINC 404	DPK MIL-C-83733	DPA
						
Type	Plug and Socket	Plug and Socket	Plug and Socket	Plug and Socket	Plug and Socket	Plug and Socket
Current Rating	see ARINC 600	see ARINC 600	MIL-C-39029	MIL-C-39029	MIL-C-39029	MIL-C-39029
Contact Resistance	MIL-C-39029	MIL-C-39029	MIL-C-39029	MIL-C-39029	MIL-C-39029	MIL-C-39029
Contact Material	MIL-C-39029	MIL-C-39029	MIL-C-39029	MIL-C-39029	MIL-C-39029	MIL-C-39029
Shell	see ARINC 600	see ARINC 600	MIL-C-81659	various	MIL-C-83733	
Shell Material	Aluminum Alloy	Aluminum Alloy	Aluminum Alloy	Aluminum Alloy	Aluminum Alloy	Aluminum Alloy
RoHS	*	*	*	*	*	*
Space Applications	No	No	No	No	Yes	No
Page Number	4	23	27	43	77	94

* RoHS compatible connectors are available upon request see “How to Order” guides for specific call outs for each product line.

** Note MIL-C-81659, MIL-C-83733 and MIL-C-39029, the US Government no longer maintains these documents, various standards agencies have assumed the role of maintaining these standards however, there can be differences in these “commercial” versions. ITT recommends for technical definitions of its products the last active versions of MIL documents be used.

Introduction	2
Product Overview Guide	3
BKAD/E/F (ARINC 600)	4
SGA (ARINC 600)	23
DPXNE/NA (MIL-C-81659)	27
DPX (ARINC 404)	43
DPXA/DPXB/DPX*MA/DPX*ME	
DPX2/DPX2MA/DPX2ME	
DPX3/DPX3MA/DPX3ME/DPX4/DPX4MA/DPX4ME	
DPK (MIL-C-83733)	77
DPA	94
DPGM/DPJM/DPJMB	
DPD/DPDMA/DPD2/DPD2MA	



BKAD/E/F

- Low insertion force contacts.
- Both environmental and non- environmental versions.
- Polarizing posts that are removable from the mating face.
- Field replaceable inserts for size 22 and power contacts.
- Up to 800 size 22 contacts in one connector.
- Crimp, coax, power, printed circuit and wire wrappable post style contacts.
- Uses standard DPX crimp, insertion/extraction tooling.
- Waveguide connections available.



BKAD/E

Rear Release/Rear Removable
Size 12, 16, 20, 22 Crimp Contacts

BKAD/E connectors represent the standard for new avionic systems developed to support the air transportation market. Several important design concerns have been addressed and solved in this new series. High mating forces of pluggable modules in a rack have been reduced by approximately two-thirds.

The low insertion force contacts are also interchangeable with the contacts used in the DPX series and permit retrofit of existing equipment.

BKAF

Front Release/Front Removable
Size 22 Solder Tail and Wrap Post Contacts

This new connector is totally intermateable and intermountable with ARINC 600 connectors now in the field.

The BKAF permits the user to easily replace a contact in case of problems, rather than disassemble the entire connector--it is available with size 22 contacts in wrap post or solder-tail versions. The system maintains the advantages of low insertion force technology incorporated in all ARINC 600 connectors.

Pos-Aline Connector Construction Feature

In the ARINC 600 connector series, Size 22 contacts are the only size that utilize this design feature. The hooded socket extends from its insulator while the pin contacts are shrouded by its front insulator. All other contacts used in this series employ standard contact design.

The result is that the complement of contacts for the plug connectors will consist of pin contacts for size 22 and socket contacts for all others. The receptacle contacts will be just the reverse, socket contact for size 22 and pin contacts for the balance.

Material Specifications

		BKAD	BKAE	BKAF	Specifications
Shell & Waveguide	Material	Aluminum alloy	Aluminum alloy	Aluminum alloy	QQ A-591/A380
	Finish	Alodine 1200	Alodine 1200	Alodine 1200	MIL-C-5541
Insulator	Material	Thermoset	Thermoset	Thermoset	N/A
	Material	Copper alloy	Copper alloy	Copper alloy	QQ-C-533
Contacts	Finish	Gold over Nickel	Gold over Nickel	Gold over Nickel	MIL-G-45204
	Termination	Crimp	Crimp	P.C./Wrap Post	N/A
Grommets/Seals	Material	N/A	Silicone-based Elastomer	N/A	N/A
O-Ring	Material	N/A	Silicone-based Elastomer	N/A	N/A



Dimensions shown in inch (mm)
Specifications and dimensions subject to change

www.ittcannon.com

How to Order



* = For Polarizing Position greater than 99, add third digit.

CONNECTOR SERIES

BKA (Per ARINC 600)

RoHS version

R - RoHS compatible

CLASS

- D - Non-environmental (rear release, crimp contacts)
- E - Environmental (rear release, crimp contacts)
- F - Non-environmental (front release, solder and wrap post #22 contact, rear release all others)
- C - Same as E, except uses BKAD shells and Less 0 rings on plug side.
- T - Non-environmental connector using filtered contacts

SHELL SIZE

- 1 - Max. contact capacity - 125
- 2 - Max. contact capacity - 400
- 3 - Max. contact capacity - 800

CONNECTOR LAYOUT DESCRIPTION

(See page 8)

SIZE 1 COAX INSERT MODIFIER

M - Connector contains modified 71W1 or 2W2 insert (four MTG screw hole locations and coaxial contact used in this insert are interchangeable between different manufacturers)

SHELL STYLE

- 3 - Plug (rack side)
- 4 - Receptacle (box side)

CONNECTOR MOUNTING MODIFIER

- 00 - Standard design, .148 dia. holes
- 01 - With #6-32 ESNA (#12 NCFMA2-62) clinch nuts (see chart)

Connector Size	Number of Clinch Nuts	
	Plug	Receptacle
1	4	4
2	4	6
3	8	10

- 02 - Size 1 receptacle only - less 3 printed circuit board mounting lugs
- 03 - With #4-40 ESNA (#22 NCFMA2-40) clinch nuts (see chart)
- 08 - Size 2 and 3 plug and receptacle only - with #4-40 ESNA (#22 NCFMA2-40) clinch nuts (all mounting holes)
- 09 - Size 2 and 3 plug and receptacle only - with #6-32 ESNA (#12 NCFMA2-62) clinch nuts (all mounting holes)
- 22 - Same as - 00 mounting modification except with nickel finished shells .0008 - .0012 thick with EMI grounding spring for plug shells and supplied with non-environmental inserts.
- 23 - With floating eyelets (.048 min. radial float) 4 corner holes per connector.

NOTE: A dash must be inserted whenever code does not apply.

Consult Customer Service if other modifications are required

How to Order (continued)

CONNECTOR LAYOUT DESCRIPTION Note: All layouts with "OPEN" insert cavity are not supplied with an insulator. If a Blank insert is required please consult factory.
Three Digit Number Contained within the Shell Layout Indicates Total Number of Contacts Available (including Waveguide)

Connector Layout	Shell Size	Shell Cavity Identification						Ref. ARINC Characteristic	Connector Layout	Shell Size	Shell Cavity Identification						Ref. ARINC Characteristic
		A	B	C	D	E	F				A	B	C	D	E	F	
-005	1	OPEN	OPEN	5W2					-T173	2	150	10T10	13W2				
-060	1	OPEN	60	OPEN					234	2	150	71W1	13W2				709
A060	1	60	OPEN	OPEN					A234	2	71W1	150	13W2				727
-065	1	OPEN	60	5W2					-246	2	120T2	120T2	6T6				
A065	1	60	Open	5W2					-248	2	121	121	6T6				
-120	1	60	60	OPEN					250	2	OPEN	150	100				
-125	1	60	60	5W2				•	250A	2	150	BLANK	100				
-013	2	OPEN	OPEN	13W2					-251	2	Waveguide	150	100				
-017	2	2W2	2W2	13W2					-300	2	150	150	OPEN				
-071	2	OPEN	71W1	OPEN					-306	2	150	150	6T6				
A071	2	71W1	OPEN	OPEN					-313	2	150	150	13W2				• • •
-085	2	Waveguide	71W1	13W2					-370	2	150	120T2	100				
A085	2	71W1	Waveguide	13W2					-400	2	150	150	100				
86M	2	2W2	71W1A	13W2					-021	3	4W4	4W4	13W2	BLANK	OPEN	OPEN	
-093	2	4W4	4W4	85					-026	3	OPEN	OPEN	13W2	OPEN	OPEN	13W2	
-100	2	OPEN	OPEN	100					-113	3	OPEN	OPEN	100	OPEN	OPEN	13W2	
-137	2	121	10T10	6T6					-A113	3	OPEN	OPEN	13W2	OPEN	OPEN	100	
-T141	2	120T2	10T10	13W2					-114	3	4W4	4W4	13W2	4W4	4W4	85	
-142	2	71W1	71W1	OPEN					-284	3	71W1	71W1	OPEN	71W1	71W1	OPEN	
-155	2	71W1	71W1	13W2				• •	-310	3	71W1	71W1	13W2	71W1	71W1	13W2	
155M	2	71W1A	71W1A	13W2					-330M	3	2W1	2W2	13W2	150	150	13W2	
V155M	2	71W1B	71W1A	13W2					-A330M	3	150	150	13W2	2W2	2W2	13W2	
158M	2	2W2	71W1A	85					-496	3	121	121	6T6	121	121	6T6	
-A158M	2	2W2	71W1B	85					-600	3	150	150	OPEN	150	150	OPEN	
-163	2	OPEN	150	13W2					-626	3	150	150	13W2	150	150	13W2	• • • •
A163	2	150	OPEN	13W2					-713	3	150	150	100	150	150	13W2	
-164	2	150	Waveguide	13W2					A713	3	150	150	13W2	150	150	100	
A164	2	Waveguide	150	13W2				708	-734	3	150	150	100	150	150	3W	
165M	2	150	2W2	13W2					-764	3	150	150	64	150	150	100	
-A165M	2	2W2	150	13W2					-800	3	150	150	100	150	150	100	
-167	2	4W4	150	13W2					-269M	3	2W2	2W2	13W2	2W2	150	100	732
173M	2	2W2	71W1B	100					271C	3	4W4	4W4	13W2	BLANK	150	100	
									271M	3	2W2	2W2	13W2	4W4	150	100	
									-326	3	OPEN	150	13W2	OPEN	150	13W2	

NOTE. ANY OTHER COMBINATION OF INSERTS WITHIN A SPECIFIC SHELL IS AVAILABLE UPON REQUEST

- Layout included in the following ARINC configurations 702, 710, 711, 712, 714, 715, 716, 723.
- • Layout included in the following ARINC configurations 707, 718 & 730.
- • • Layout included in the following ARINC configurations 701, 702, 703, 704, 705, 706, 724, 725.
- • • • Layout included in the following ARINC configurations 701, 717, 726, 729.

POLARIZING POSITION

01 thru 216 (per ARINC 600)

Blank-Polarizing posts or keys not installed but supplied with connector

MODIFIER (Contact, Finish, Material)

- Blank - Rear release, crimp, signal and power contacts supplied with connector (when applicable)
- FO - Contacts not supplied with connector (FO not stamped on connector)
- FOO - Less contacts and waveguide (FOO not stamped on connector)
- SA - Front release .025(0.63) D. x .150 (3.81) solder post and crimp, rear release power contacts (when applicable) supplied with connector
- SB - Front release .025(0.63) D. x .250 (6.35) solder post and crimp, rear release power contacts (when applicable) supplied with connector

- SC - Front release .025(0.63) D. x .375 (9.53) solder post and crimp, rear release power contacts (when applicable) supplied with connector
- SD - Front release .025(0.63) D. x .500 (12.7) solder post and crimp, rear release power contacts (when applicable) supplied with connector
- WA - Front release .025(0.63) Sq. x .250 (6.35) (1 wrap) wrap post and crimp, rear release power contacts (when applicable) supplied with connector
- WB - Front release .025(0.63) Sq. x .375 (9.53) (2 wraps) wrap post and crimp, rear release power contacts (when applicable) supplied with connector

- WC - Front release .025(0.63) Sq. x 500 (12.7) (3 wraps) wrap post and crimp, rear release power contacts (when applicable) supplied with connector
- WD - Front release .025 (0.64) Sq. x 641 (16.28) (3 wraps) wrap post and crimp, rear release power contacts (when applicable) supplied with connector

NOTE: COAXIAL CONTACTS TO BE ORDERED SEPARATELY



Dimensions shown in inch (mm)
Specifications and dimensions subject to change

www.ittcannon.com

Shell Dimensions - Size 1

Plug

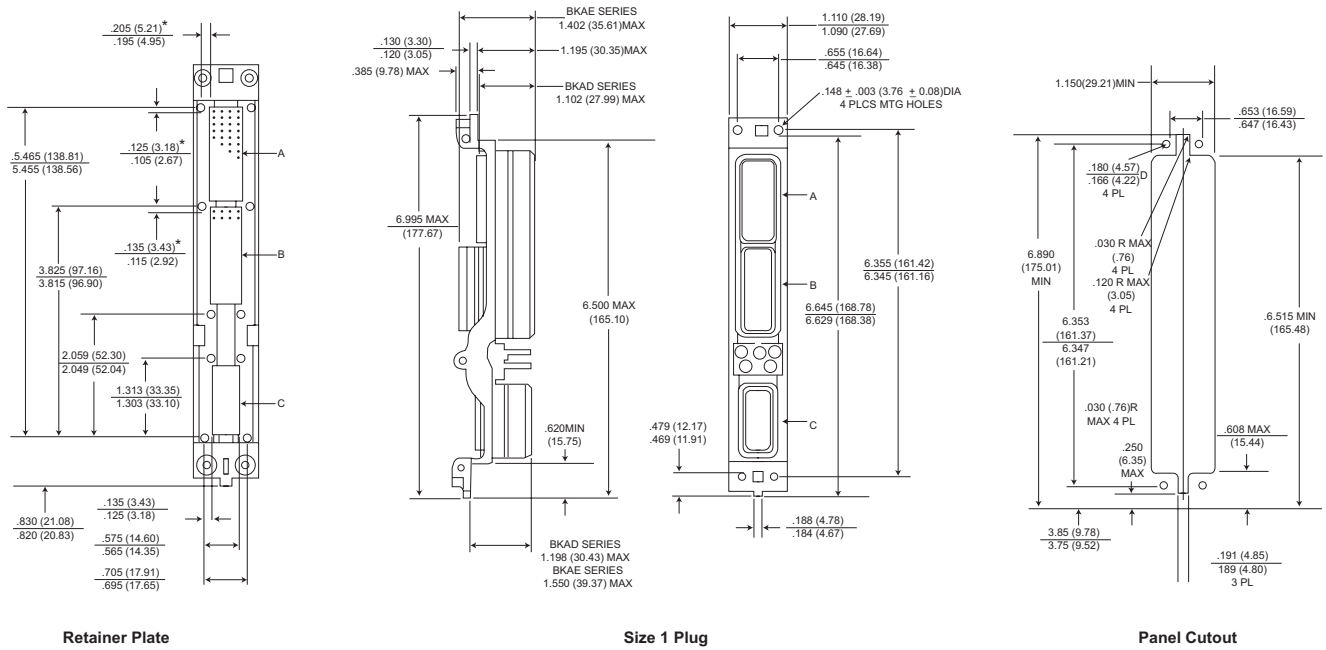

* This dimension indicates distance from centerline of retaining screw to the centerline of first contact cavity.

For further information, refer to ARINC 600 specification or consult factory.

Receptacle

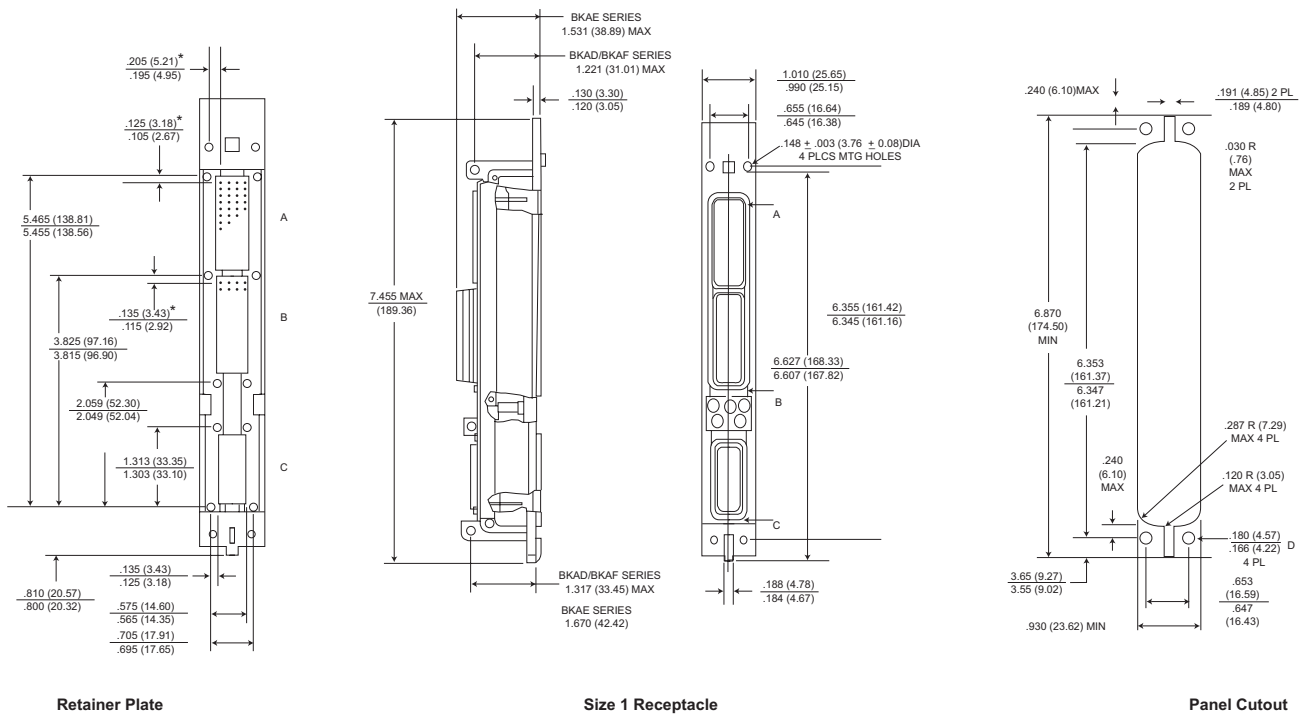

*This dimension indicates distance from centerline of retaining screw to the centerline of first contact cavity.

For further information, refer to ARINC 600 specification or consult factory.

Dimensions shown in inch (mm)
Specifications and dimensions subject to change

www.ittcannon.com



Shell Dimensions- Size 2

Plug

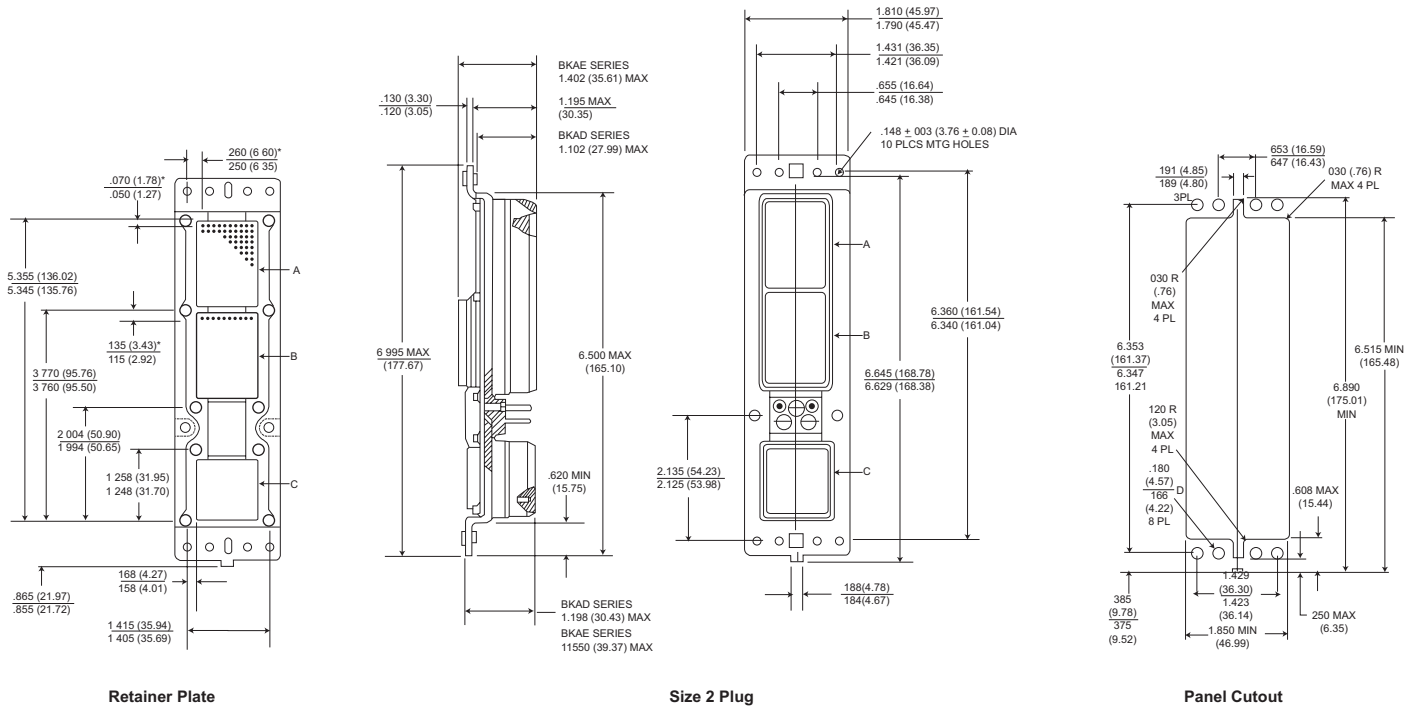

* This dimension indicates distance from centerline of retaining screw to the centerline of first contact cavity.

For further information, refer to ARINC 600 specification or consult factory.

Receptacle

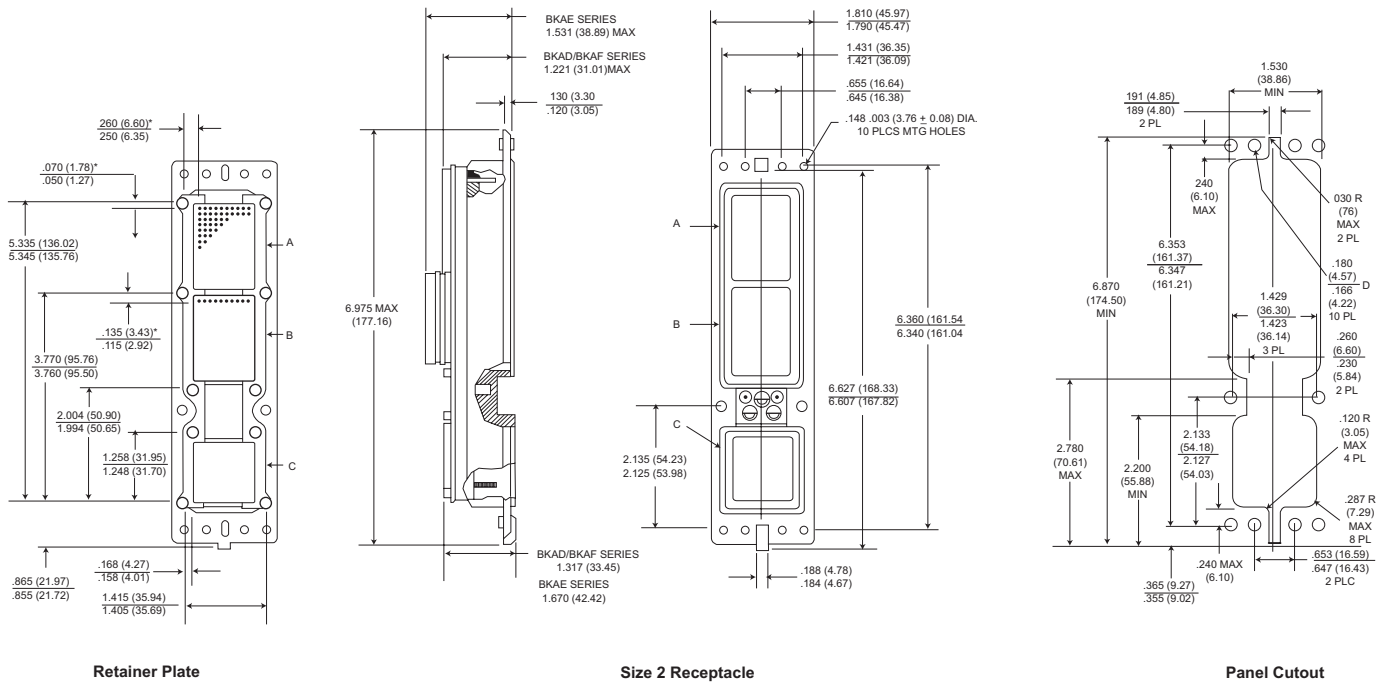

*This dimension indicates distance from centerline of retaining screw to the centerline of first contact cavity.

For further information, refer to ARINC 600 specification or consult factory.



Dimensions shown in inch (mm)
Specifications and dimensions subject to change

www.ittcannon.com

Shell Dimensions- Size 3

Plug

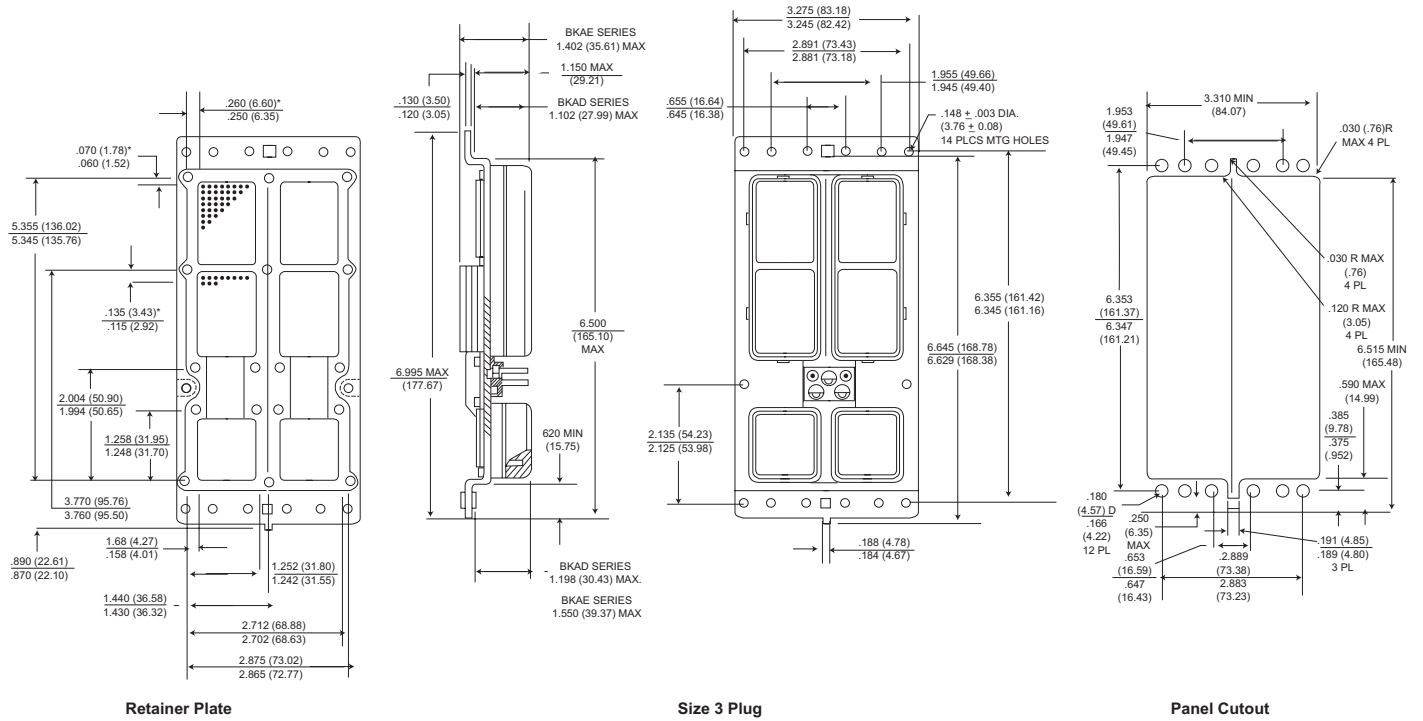

* This dimension indicates distance form centerline of retaining screw to the centerline of first contact cavity.

For further information, refer to ARINC 600 specification or consult factory.

Receptacle

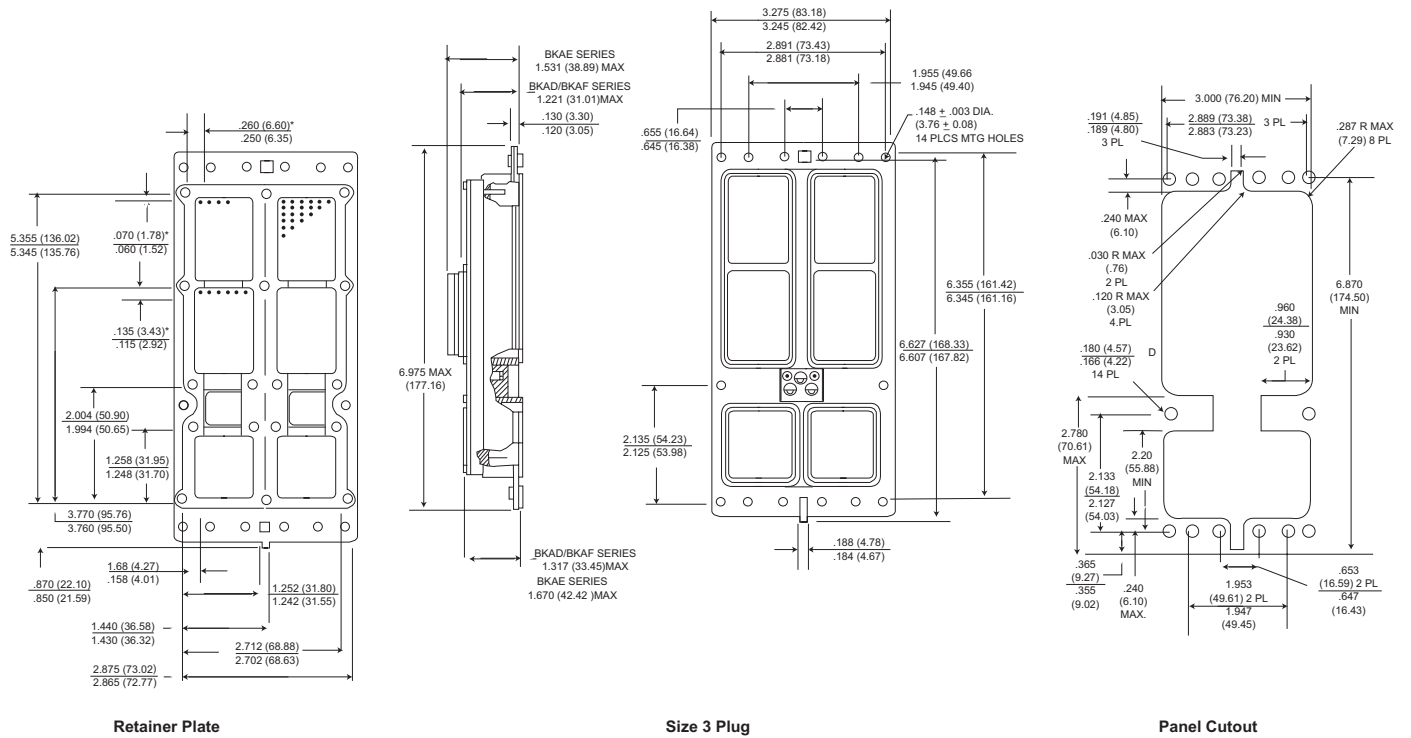

* This dimension indicates distance form centerline of retaining screw to the centerline of first contact cavity.

For further information, refer to ARINC 600 specification or consult factory.

Dimensions shown in inch (mm)
Specifications and dimensions subject to change



Contact Arrangements - Shell Size 1

BKAD/BKAE (Plug Rear face shown)

Shell Cavity
A or B

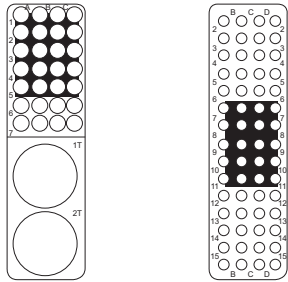

30T2
28 #22
2 #8 TWINAX/COAX
(#8 Grounded to Shell)

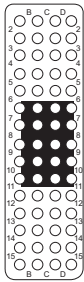

60
60 #22

Shell Cavity
C

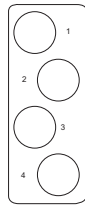

4
4 #12

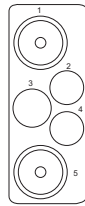

5W2
1 #12
2 #16
2 #5 COAX

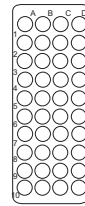

40
40 #22

BKAF - Available Receptacle Shell Only
(Front Release)

Shell Cavity
A or B

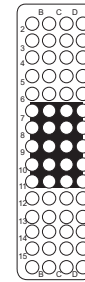

60
60 #22

Shell Cavity
C

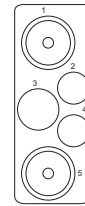

5W2
1 #12
2 #16
2 #5 COAX

ENGAGING END SURFACE WHITE ON RED TO INDICATE FRONT RELEASE FRONT REMOVAL CONTACTS

REAR SURFACE WHITE ON BLUE TO INDICATE REAR RELEASE REAR REMOVAL CONTACTS

(For Contact Cavity Location and Contact Cavity Identification refer to ARINC 600 or consult factory)

Contact Arrangements - Shell Sizes 2 and 3

BKAD/BKAE (Plug Rear face shown)

Shell Cavity
C or F

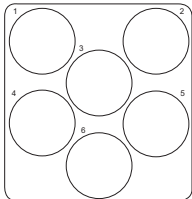

6**
6 #8

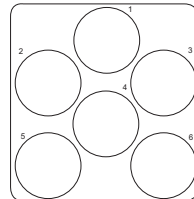

6T6**
6 #8 TRIAX
(Metallic Insert)

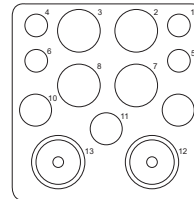

13W2
4 #20, 4 #12, 3 #16
2 #5 COAX

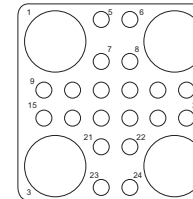

24T4**
20 #20, 4 #8 TRIAX

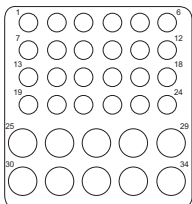

34**
24 #20 HD, 10 #16

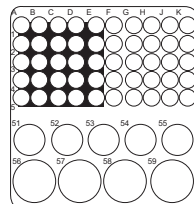

59**
50 #22, 5 #16, 4 #12

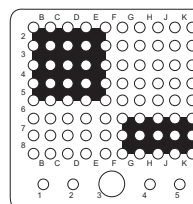

85
80 #22, 4 #20, 1 #16

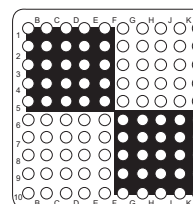

100
100 #22

**Pending ARINC release.

NOTE: In layouts using #22 contacts mixed with any other contact size (20HD, 16, 12), the size #22 contact type (pin or socket) determines the insulator as a pin insert or a socket insert.

REAR SURFACE WHITE ON BLUE TO INDICATE REAR RELEASE, REAR REMOVAL CONTACTS FOR INSERTS CONTAINING STANDARD SIGNAL & POWER CONTACTS

(For Contact Cavity Location and Contact Cavity Identification refer to ARINC 600 or consult factory)



Dimensions shown in inch (mm)
Specifications and dimensions subject to change

www.ittcannon.com

Contact Arrangements - Shell Sizes 2 and 3

BKAD/BKAE (Plug Rear face shown)
 Shell Cavity
 A,B,D,E

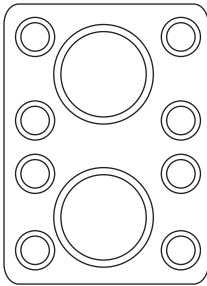

2W2
2 #1 COAX

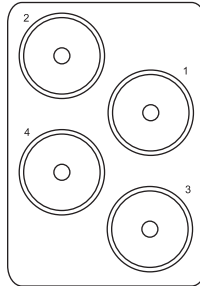

4W4
4 Modified #1 COAX (Metallic Insert)

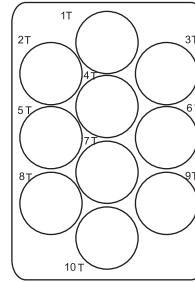

10T10**
10 #8 TRIAX/COAX (#8 Grounded to Shell) (Metallic Insert)

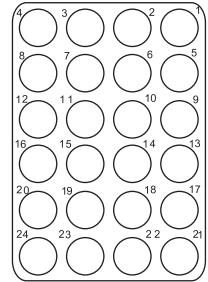

24**
24 #12

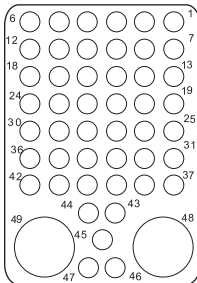

49T2**
47 #20
2 #8 TRIAX

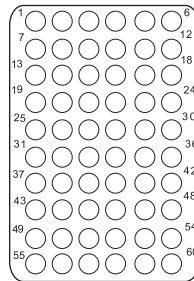

60**
60 #20

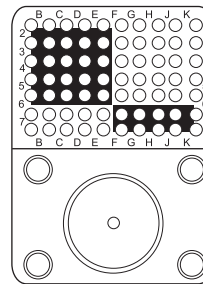

71W1
70 #22
1 #1 COAX

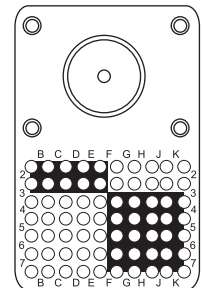

71W1B
70 #22
1 #1 COAX

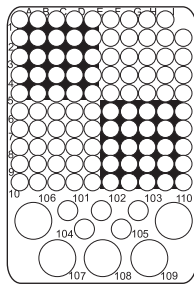

110**
100 #22
5 #12 & 5 #20

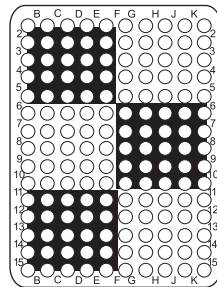

150
150 #22

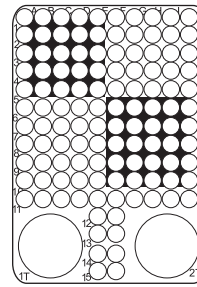

120T2 **
118 #22
2 #8 TWINAX/COAX (#8 Grounded to Shell)

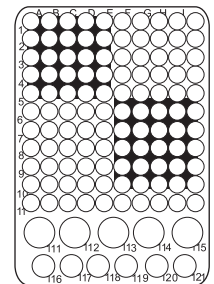

121**
110 #22
5 #16
6 #20

** Pending ARINC release.

REAR SURFACE WHITE ON BLUE TO INDICATE REAR RELEASE. REAR REMOVAL CONTACTS FOR INSERTS CONTAINING STANDARD SIGNAL & POWER CONTACTS

(For Contact Cavity Location and Contact Cavity Identification refer to ARINC 600 or consult factory)

Contact Arrangements - Shell Sizes 2 and 3

BKAF - Available Receptacle Shell ONLY
 (Front Release)
 SHELL CAVITY
 A, B, D, E,

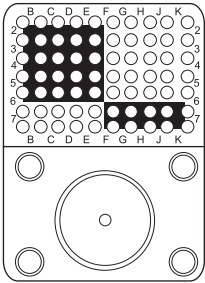

71W1
70 #22

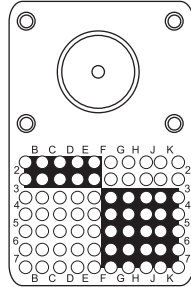

71W1B
70 #22

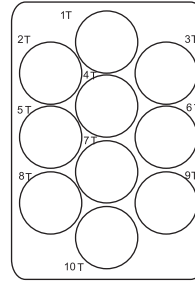

10T10**
10 #8

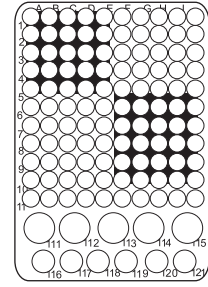

121F**
110 #22
6 #20
5 #16

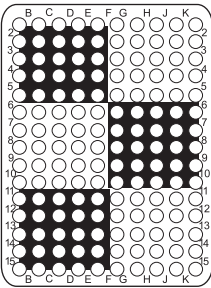

150
150 #22

ENGAGING END SURFACE WHITE ON RED TO INDICATE FRONT RELEASE FRONT REMOVAL CONTACTS FOR INSERTS CONTAINING STANDARD SIGNAL & POWER CONTACTS

BKAF - Available Receptacle Shell ONLY
 (Front Release)
 SHELL CAVITY C, F

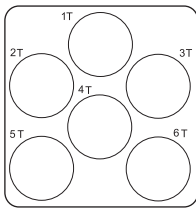

6T6**
6 #8 TRIAX

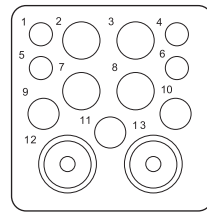

13W2
4 #20
3 #16
4 #12
2 #5 COAX

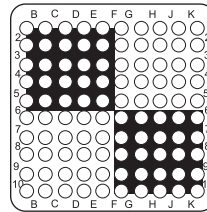

100
100 #22

** Pending ARINC release.

NOTE #22 CONTACTS ARE SOCKETS, 20HD,16, 12 ARE PIN CONTACTS.

ENGAGING END SURFACE WHITE ON RED TO INDICATE FRONT RELEASE, FRONT REMOVAL CONTACTS FOR INSERTS CONTAINING STANDARD SIGNAL & POWER CONTACTS

(For Contacts Cavity Location and Contact Cavity Identification refer to ARINC 600 or Consult Factory)



Dimensions shown in inch (mm)
 Specifications and dimensions subject to change

www.ittcannon.com

Waveguide Connections

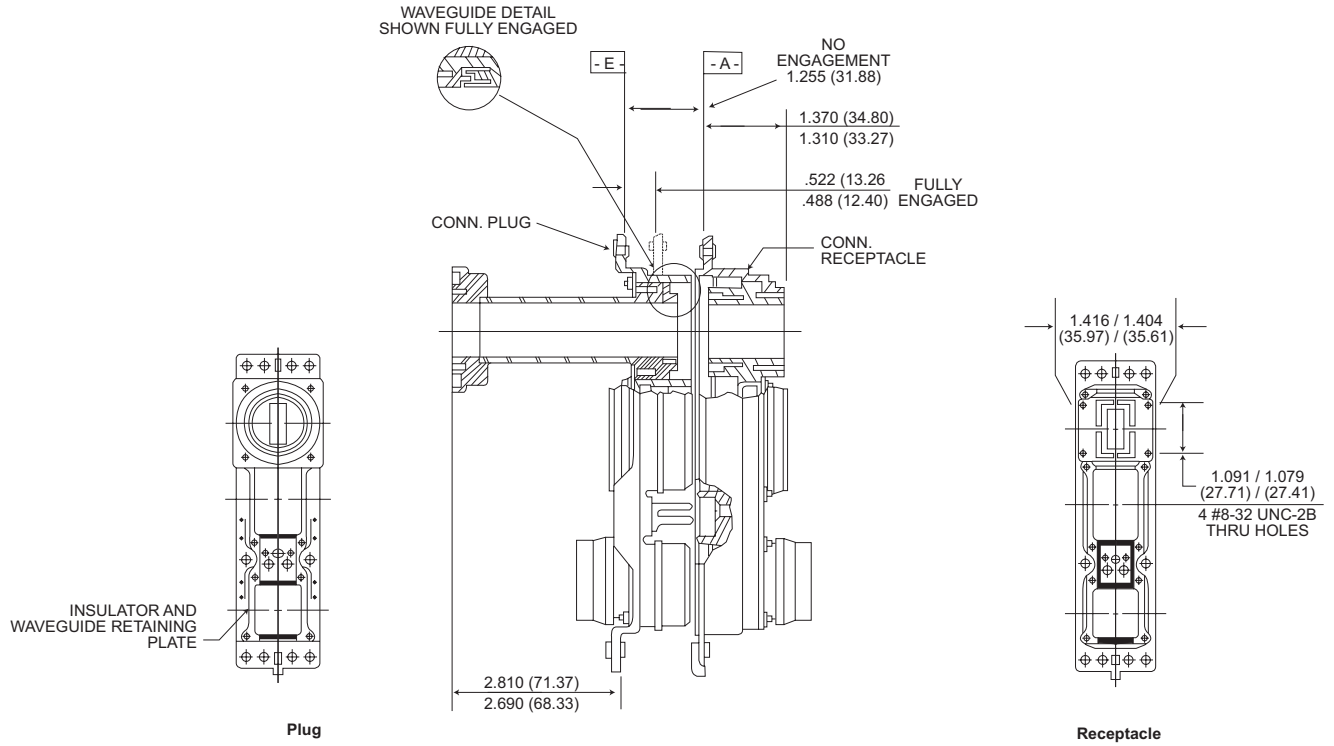

Polarization (Engaging End)

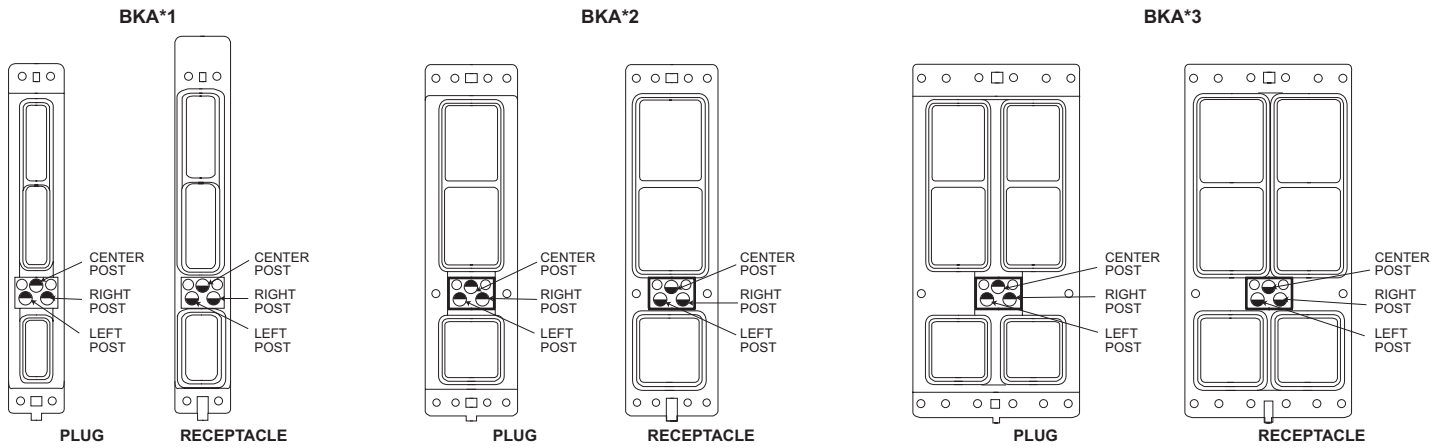

Dimensions shown in inch (mm)
Specifications and dimensions subject to change

www.ittcannon.com



Contact and Termination Tooling Data

BKA* (LIF) Crimp Contacts

Contact Size and Part Numbers			Crimp Tooling					Insertion/Extraction Tooling			Wire Size			
Size	Part Numbers		Tool P/N		Selec-tor#	Locator P/N		MIL Spec.	ITT Cannon			AWG	Insul Dia. Max	Strip Length
	Pin	Socket	MIL Spec.	ITT Cannon		Mil Spec.	ITT Cannon		Insertion	Extraction	Ins./Ext.			
2222	Used in Plug 030-2259-000	Used in Recep. 031-1287-000	M22520 /2-01	995-0001- 584	3 3 4	M22520 /2-23	995-0002- 015	M81969 /1-01	CIT-DPXMA-22-1 Metal 070256-0000	CET-DPXMA-22 Metal 070317-0000	980-0004-804 Metal Tip	26 24 22	.054 (1.4)	.130/.110 (3.3)/(2.8)
2020HD	Used in Recep 030-2273-000	Used in Plug 031-1302-000	M22520 /2-01	995-0001- 584	6 7	M22520 /2-08	995-0001- 604	M81969 /1-02	-	-	980-0004-805 Metal Tip	22 20	.071 (1.8)	.167/.147 (4.2)/(3.7)
1616	Used in Recep 030-2280-000	Used in Plug 031-1303-000	M22520 /1-01	995-0001- 585	4 5 6	M22520 /1-02	995-0001- 736	M81969 /1-03	-	CET 16-9 Plastic	980-0004-806 Metal Tip	20 18 16	.103 (2.6)	.207/.230 (6.9)/(5.8)
1212	Used in Recep 030-2286-000	Used in Plug 031-1308-000	M22520 /1-01	995-0001- 585	7 8	M22520 /1-11	995-0002- 027	M81969 /14-04	-	CET 12-4 Plastic	CIET-12 Plastic	14 12	.135 (3.4)	.270/.230 (6.9)/(5.8)

BKA* Thermocouple Contacts

Contact Size and Part Numbers			Crimp Tooling					Insertion/Extraction Tooling			Wire Size			
Size	Part Number		Tool P/N		Selec-tor#	Locator P/N		MIL Spec.	ITT Cannon			AWG	Insul Dia. Max	Strip Length
	Pin	Socket	MIL Spec.	ITT Cannon		Mil Spec.	ITT Cannon		Insertion	Extraction	Ins./Ext.			
2222 Alumel	Used in Plug 030-1975-009	Used in Recep. 031-1113-009	M22520 /2-01	995-0001 584	3	M22520 /2-23	995-0002- 015	M81969 /1-01	CIT-DPXMA-22-1 Metal 070256-0000	CET-DPXMA-22 Metal 070317-0000	980-0004-804 Metal Tip	26 24 22	.054 (1.4)	.130/.110 (3.3)/(2.8)
2222 Chromel	Used in Plug 030-1975-010	Used in Recep. 031-1113-010			4									

BKAF-ARINC 600 Size 22 Wrap Post Socket Contacts With .025(6.35) Square Wire-Wrappable Tails-Receptacle Only.

The new low insertion force, front-insertable, front-removable #22 socket contacts with .025(6.35) square wire wrappable tails are now available for use in the BKAF non-environmental receptacle version only. These contacts can be sold separately or they can be supplied with a connector (see How to Order). Use part numbers shown in the table on the right when ordering separately.

Contact Mod.	Part Number	Number of Wraps	Min. Post Extension	Extraction Tool
WA	031-1351-000	1	.250 (6.35)	CET-22F 317-1798-001
WB	031-1351-001	2	.375 (9.52)	
WC	031-1351-002	3	.500 (12.70)	
WD	031-1351-003	3	.641 (16.28)	

BKAF Printed Circuit Solder Post Socket Contacts Size 22 with .025(6.35) Dia. Printed Circuit Tails-Receptacle Only.

The new low insertion force, front-insertable, front-removable #22 socket contacts with .025(6.35) dia., PC tails are now available for use in the BKAF non-environmental receptacle version only. These contacts can be sold separately or they can be supplied with a connector (see How to Order). Use part numbers shown in the table on the right when ordering separately.

Contact Mod.	Part Number	Min. Post Extension	Extraction Tool
SA	031-1352-000	.150 (3.81)	CET-BKAF 22S
SB	031-1352-001	.250 (6.35)	
SC	031-1351-002	.375 (9.52)	
SD	031-1352-003	.500 (12.70)	

BKAD/F Solder Post, Power Pin Contacts (Captive)-Receptacle Only.

Contacts are captivated between two unbonded insulator halves.

Contact Size	Part Number	Post Dia.	Min. Post Extension*
2D HD	030-2358-000	.032 (0.81)	.150 (3.81)
16	030-2357-000	.050 (1.27)	.150 (3.81)
12	030-2356-000	.081 (2.06)	.150 (3.81)

*Consult factory for other available lengths

BKAF Solder Post Pin Contact Front Release

Contact Size	Part Number	Post Dia.	Min. Post Extension	Extraction Tool
20HD	030-3287-000	.030 (0.76)	.300* (7.62)	317-1798-000
16HD	030-3287-001	.050 (1.27)	.300* (7.62)	317-1798-002
12HD	030-3287-002	.081 (2.06)	.300* (7.62)	317-1798-002

*Applies to BKAF 13W2 and 5W2 inserts only

Front Release Pin Contacts Size 20 and 16

Contact Size	Part Number	PC Tail Dia.	Min. Post Extension
20	030-3296-001	.034 (0.86)/.030 (0.76)	.260 (6.60)
20	030-3296-002	.034 (0.86)/.030 (0.76)	.385 (9.78)
16	030-3297-001	.052 (1.32)/.048 (1.22)	.260 (6.60)
16	030-3297-002	.052 (1.32)/.048 (1.22)	.385 (9.78)
16	030-3297-005	.052 (1.32)/.048 (1.22)	.300 (7.62)
20	030-3296-004	.034 (0.86)/.030 (0.76)	.300 (7.62)

Dimensions shown in inch (mm)

Specifications and dimensions subject to change

Size 5 Coax Contact (Rear insertable/removable)

Crimp Center Contact-Conforming to ARINC 600

Cable Accommodation	Part Number		Crimp Tooling							Extraction Tool
			Center Contact				Outer Shell			
	Pin (Receptacle Connector)	Socket (Plug Connector)	Tool		Locator		MIL STD		ITT Cannon	
			MIL Spec	ITT Cannon	Daniels	ITT Cannon	Frame	Jaw	Complete Tool	
RG-58C/U BA-5903 (BG)	349-0014-000	349-0013-000	M22520/2-01	995-0001-584	K-345	995-0002-049	M22520/5-01	M22520/5-45B	CCT-HX3-156	CET-C8
5021K1011 (Raychem)	349-0016-000	349-0015-000	M22520/2-01	995-0001-584	K-345	995-0002-049	M22520/5-01	M22520/5-45B	CCT-HX3-156	CET-C8
RG-223	349-1060-000	349-1059-000	M22250/2-01	995-0001-584	K-345	995-0002-049	M22520/5-01	M22520/5-45B	CCT-HX3-156	CET-C8
RG-400	-	349-1003-000	M22250/2-01	995-0001-584	K-345	995-0002-049	M22520/10-01	M22520/10-23	-	CET-C8
RD-316	-	349-1004-000	M22250/2-01	995-0001-584	K-345	995-0002-049	M22520/10-01	M22520/10-23	-	CET-C8

Size 12 Shielded Contact (Rear insertable/removable)

Cable Accommodation	Part Number		Crimp Tooling							Tool	
			Center Contact				Outer Shell Tool				
	Pin (Receptacle Connector)	Socket (Plug Connector)	Tool P/N		Locator P/N		MIL Std		ITT Cannon	MIL Spec	ITT Cannon
			MIL Spec	ITT Cannon	Daniels	ITT Cannon	Frame	Jaw			
RG-196A/U	249-1767-000	-	M22520/2-01	995-0001-584	K-182	995-0002-051	M22520/1-01	M22520/10-05A	995-0001-071	M81969/28-02	CET-12-4 Plastic
5071 (HW)	249-1767-001	-	M22520/2-01	995-0001-584	K-182	995-0002-051	M22520/1-01	M22520/10-05A	995-0001-071	M81969/28-02	CET-12-4 Plastic
RG-174/U	-	249-1768-000	M22520/2-01	995-0001-584	K-182	995-0002-051	M22520/1-01	M22520/10-05A	995-0001-071	M81969/28-02	CET-12-4 Plastic
BMS-1348 (BG)	-	249-2203-000	M22520/2-01	995-0001-584	K-644	995-0002-050	M22520/1-01	M22520/10-05A	995-0001-071	M81969/28-02	CET-12-4 Plastic
RG-316	249-1767-005	-									

Size 1 Modified Coaxial Contacts (4W4 Layout Only)

Plug Connector

Cable Accommodation	Part Number	Coax Style	Replacement Termination Kits	
			Solder Type	CrimpType
RG214	349-1043-001	Straight	320-1066-000	320-1066-016
AA-5886	349-1048-000	Straight	320-1066-002	320-1066-018
RG393	349-1051-000	Straight	320-1066-003	320-1066-019
ECS 311201	349-1046-000	Straight	320-1066-001	320-1066-017
AA-5887	349-1049-000	Straight	320-1066-004	320-1066-013
AA-5888	349-1050-000	Straight	320-1066-005	320-1066-014
RG142	349-1047-000	Straight	320-1066-006	320-1066-015
Various	349-1047-001	TNC Adapter	-	-

Customer Use Drawings:

All Coax contacts (except 349-1047-001) customer use drawing #349-0000-305
 Crimp termination kits: Customer use drawing #320-0000-305
 Solder termination kits: Customer use drawing #320-0000-304

Receptacle Connector

Cable Accommodation	Part Number	Coax Style	Replacement Termination Kits	
			Solder Type	CrimpType
RG316 DS	349-1051-002	Straight	320-1066-008	N/A
RG142	349-1044-000	Straight	320-1066-007	N/A
Various	349-1042-000	SMA Adapter	-	-

Customer Use Drawings:

Coax contacts 349-1051-002 and 349-1044-000 are located on customer use drawing #349-0000-304
 Coax contacts 349-1042-000 is located on customer use drawing #320-1042-000

Dimensions shown in inch (mm)
 Specifications and dimensions subject to change



Sizes 1 Coax Contacts (71W1 layout only)

Same standard coax contacts as used in ITT's DPX (ARINC 404) connector series.

Receptacle Connector

Cable Accommodation	Coax Part Number	Style	Replacement Coax Termination Kit	Replacement Coax Body Assembly
RG-9/U RG-214/U	249-1521-000		249-1521-002	021-0144-000
NSA 935354 NSA 935355	-		249-2201-000	
RG-55/U RG-58/U RG-142/U RG-400/U	249-1554-000	Straight	249-1554-002	021-0144-003
RG-58/U RG-142/U RG-225/U	249-1604-001	90°	249-1604-003	021-0144-006
RG-402/U UT-141	249-1604-002			
RG-402/U UT-141	249-5027-008	Straight	249-5027-016	021-0144-001
SMA Jack Termination	249-5027-017	Straight	-	-

Plug Connector

Cable Accommodation	Coax Part Number	Style	Replacement Coax Termination Kit	Replacement Coax Body Assembly
RG-9/U	249-1522-000	Straight	249-1522-010	021-0144-004
NSA 935354 NSA 935355	-		249-2202-000	
RG-58/U RG-142/U	249-1882-000		249-1882-001	
RG-402/U	249-1885-002	Straight	320-0051-000	021-0144-011
RG-214/U	249-5123-000	Straight	249-5027-013	021-0144-008
RG-115/U	249-5123-001		249-5027-015	

Sizes 1 Coax Contacts (To be used with connectors containing 71W1A, 71W1B and 2W2 insert modifier-"M")

Designed to be interchangeable with contacts made by other manufacturers.

Receptacle Connector

Cable Accommodation	Part Number	Style
RG-142B/U	349-0021-000	Right Angle
RG-402/U UT-141	349-0022-000	Right Angle
SMA Jack Termination	349-0023-000	Straight
RG-214/U RG-393/U BA-6903 (BG)	349-0002-000	Straight
5012H3012 (Raychem)	349-0004-000	Straight
RG-142B/U	349-0006-000	Straight
RG-402/U UT-141	349-0008-000	Straight

Plug Connector

Cable Accommodation	Standard Size 1 Part Number	Modular Size 1 Part Number	Termination Kit for Modular Size 1 Coax	Style
RG-214/U	349-0017-000	349-1053-003	320-1066-000	Straight
RG-393/U	349-0017-000	-	-	
BA-6903	349-0017-000	349-1053-007	320-1066-003	Straight
5012H3012 (Raychem)	349-0018-000	-	-	
RG-142B/U	349-0005-000	349-1053-006	320-1066-006	Straight
RG-402/U UT-141	349-0007-000	-	-	Straight
AA-5888	-	349-1053-008	320-1066-005	Straight
ECS-310801	-	349-1053-005	-	Straight
AA-5886	-	349-1053-004	320-1066-002	Straight
BSX-7004-502	-	349-1053-003	-	Straight
ECS-311201	-	349-1053-002	320-1066-001	Straight
AA-5887	-	349-1053-001	320-1066-004	Straight
Adam Russell PC-38	-	349-1053-000	-	Straight
TNC	349-1052-003			

Dimensions shown in inch (mm)
Specifications and dimensions subject to change

www.ittcannon.com



Size 8 Coaxial Contacts

Plug Connector

Contact Type Socket Part Number	*Engagement		**Termination				RF Cable Number
			Crimp RR-RR	Crimp FR-RR	Solder .250 (6.35)	FR-FR .375 (9.52)	
	Short	Long					
349-1087-003	-	-	X				Adams-Russell Co. Inc. FC11Z
349-1087-004	-	-	X				Adams-Russell Co. Inc. FC14Z

Receptacle Connector

Contact Type Socket Part Number	*Engagement		**Termination				RF Cable Number
			Crimp RR-RR	Crimp FR-RR	FR-FR .250 (6.35)	Solder .375 (9.52)	
	Short	Long					
349-1084-000	-	X			X		
349-1084-001	X	-			X		
349-1084-002	-	X				X	
349-1084-003	X	-				X	
349-1086-000	-	X		X			Adams-Russell Co. Inc. FC11Z
349-1086-001	-	X		X			Adams-Russell Co. Inc. FC14Z

Size 8 Twinax Contacts

Plug Connector

Contact Type Socket Part Number	*Engagement		**Termination				RF Cable Number
			Crimp RR-RR	Crimp FR-RR	Solder .250 (6.35)	FR-FR .375 (9.52)	
	Short	Long					
349-1006-000	-	-	X				M17/176-00002
349-1081-001	-	-	X				Tensolite Co. 24463/9 B017X-2 (LD)

Receptacle Connector

Contact Type Socket Part Number	*Engagement		**Termination				RF Cable Number
			Crimp RR-RR	Crimp FR-RR	Solder .250 (6.35)	FR-FR .375 (9.52)	
	Short	Long					
349-1007-000	-	-	X				M17/176-00002
349-1080-000	X	-			X		
349-1080-001	-	X			X		
349-1080-002	X	-				X	
349-1080-003	-	X				X	
349-1082-000	X	-		X			Tensolite Co. 24463/9 B017X-2 (LD)
349-1082-001	-	X		X			Tensolite Co. 24463/9 B017X-2 (LD)
349-1088-001	-	X	X				Tensolite Co. 24463/9 B017X-2 (LD)

Size 8 Ground Contacts

Plug Connector

Contact Type Socket Part Number	*Engagement		**Termination				Wire Size
			Crimp RR-RR	Crimp FR-RR	Solder .250 (6.35)	FR-FR .375 (9.52)	
	Short	Long					
031-3300-000	-	-	X				8, 10 AWG

Receptacle Connector

Contact Type Socket Part Number	*Engagement		**Termination				Wire Size
			Crimp RR-RR	Crimp FR-RR	Solder .250 (6.35)	FR-FR .375 (9.52)	
	Short	Long					
030-3306-000	-	X			X		8, 10 AWG
030-3306-001	-	X				X	8, 10 AWG
030-3676-000	-	-		X			8, 10 AWG

* The electrical engagement of "Long" contacts is .150 (3.81) greater than the electrical engagement of "Short" contact.
 **RR-RR indicates rear release, rear removal.
 FR-RR indicates front release, rear removal.
 FR-FR indicates front release, front removal.

Dimensions shown in inch (mm)
 Specifications and dimensions subject to change



Sealing Plugs-BKAE Environmental Connectors Only

P/N 225-0090-000
Material: Teflon
(All others thermoplastic)

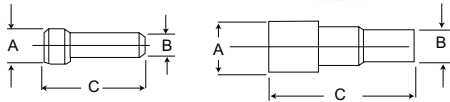

Part Number	Contact Size	Color	A	B	C
225-1013-000	22	Black	.063 (1.6)	.040 (1.0)	.469 (11.9)
225-0070-000	20	Red	.085 (2.2)	.065 (1.6)	.469 (11.9)
225-0071-000	16	Blue	.115 (2.9)	.075 (1.9)	.469 (11.9)
225-0072-000	12	Yellow	.171 (4.3)	.121 (3.1)	.564 (14.3)
225-0090-000	#5 and #9 Coax	White	.365 (9.3)	.287 (7.3)	.835 (21.2)

Filler Plugs-BKAD Non-Environmental Connectors Only

P/N 225-0099-000
Material: Teflon
(All others thermoplastic)

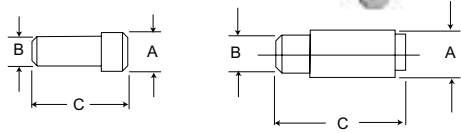

Part Number	Contact Size	Color	A	B	C
225-0094-000	22	Black	.069 (1.7)	.051 (1.3)	.420 (10.7)
225-0095-000	20	Red	.083 (2.1)	.069 (1.7)	.350 (8.9)
225-0096-000	16	Blue	.131 (3.3)	.108 (2.7)	.320 (8.1)
225-0097-000	12	Yellow	.187 (4.7)	.156 (4.0)	.320 (8.1)
225-0098-000	#5 Coax (Pin)	White	.275 (7.0)	.251 (6.4)	.450 (11.4)
225-0099-000	#5 and #9 Coax (Socket)	White	.275 (7.0)	.251 (6.4)	1.061 (26.9)

BKAF P/N 225-1058-000
(Size 22 - Black)
(See Customer Use Drawing for details)

Cavity Reducer



Pin
P/N 021-8756-000



Socket
P/N 021-8757-000

#5 Coax to #12 Contact

Cavity reducers are available when additional circuits are required for size 12 power contacts. These reducers, having the internal configuration of size 12 power contact, are inserted into the size 5 coaxial insulator cavity to create size 12 power contact cavity.

(Non removable)

Dust Caps

Conductive dust caps protect against static electricity.



Part Number	Description	Part Number	Description
025-1121-001	BKAD 1-A & B-Plug	025-1155-001	BKAD 1-A&B-Receptacle
025-1122-001	BKAD 1-C-Plug	025-1156-001	BKAD 1-C-Receptacle
025-1123-001	BKAD 2&3-A & B-Plug	025-1157-001	BKAD 2&3-A & B-Receptacle
025-1124-001	BKAD 2&3-C-Plug	025-1158-001	BKAD 2&3-C-Receptacle

Note: Supplied as standard for BKA product line only.

Replaceable Inserts

Layout	Class	Part Number	
		Pin Assembly	Socket Assembly
2W2**	BKAD	144-2944-000	144-2945-000
	BKAE	144-2944-000	144-2945-000
A	BKAE	143-1156-001	143-1157-001
4W4**	BKAD	177-1000-002	177-1001-004
	BKAE	177-1000-002	177-1001-004
5W2	BKAD	143-1912-000	143-1913-000
	BKAE	143-1912-001	143-1913-001
	BKAF	143-1141-000	N/A
6	BKAE	143-1154-001	143-1155-001
6T6	BKAD	228-1026-002	228-1012-003
	BKAE	228-1026-001	228-1012-001
	BKAF	N/A	228-1015-001
10T10	BKAD	228-1027-002	N/A
	BKAE	228-1027-001	228-1014-002
13W2	BKAD	143-1908-000	143-1909-000
	BKAE	143-1908-001	143-1909-001
	BKAF	143-1142-000	N/A
30T2	BKAD	143-1173-000	143-1174-000
	BKAE	143-1173-001	143-1174-001
34	BKAD	143-1159-001	N/A
	BKAE	143-1097-005	143-1098-005
40	BKAE	143-1171-001	143-1172-001
59*	BKAE	143-1167-001	143-1170-001
60-#20**	BKAE	143-3714-003	143-3715-003
60-#22**	BKAD	143-1910-000	143-1911-000
	BKAE	143-1910-001	143-1911-001
	BKAF	N/A	143-2065-000
71W1	BKAD	143-1958-000	143-1960-000
	BKAE	143-1958-002	143-1960-002
	BKAF	N/A	143-2090-000
71W1A*	BKAD	143-2085-001	143-2086-001
	BKAE	143-2085-000	143-2086-000
	BKAF	N/A	143-2066-000
71W1B	BKAD	143-1113-000	143-1111-000
	BKAE	143-114-000	143-1112-000
	BKAF	N/A	143-1118-000
85	BKAD	143-3877-000	143-3878-000
	BKAE	143-3879-000	143-3880-000
	BKAF	N/A	143-1178-000
100	BKAD	143-2015-000	143-2016-000
	BKAE	143-2015-001	143-2016-001
	BKAF	N/A	143-2067-000
110	BKAE	143-1182-000	143-1183-000
120T2	BKAD	N/A	143-1166-002
	BKAE	143-1165-003	143-1166-001
	BKAF	N/A	143-1177-000
121	BKAD	143-1150-002	143-1158-002
	BKAE	143-1150-001	143-1158-001
150	BKAD	143-1906-000	143-1907-000
	BKAE	143-1906-001	143-1907-001
	BKAF	N/A	143-2068-000

Consult factory for Insert Part Numbers not listed.

*Modified 71W1 insert to be used with connectors containing 71W1 insert modifier "M"

***Pin Inserts' accept receptacle coax contacts. "Socket Inserts" accept plug coax contacts.



Dimensions shown in inch (mm)
Specifications and dimensions subject to change

www.ittcannon.com

Cross Reference-Part Number/Customer-Use Drawing

COMPONENT PART NUMBER	CUSTOMER USE DRAWING NUMBER	COMPONENT PART NUMBER	CUSTOMER USE DRAWING NUMBER	COMPONENT PART NUMBER	CUSTOMER USE DRAWING NUMBER
Contacts		143-1908-000		Replacement Coax Termination Kit	
030-1975-009	030-1975-009	143-1908-001	143-0000-081	249-1521-002	249-1521-002
030-1975-010	030-1975-010	143-1909-000		249-1522-009	249-1522-010
030-2259-000	030-2259-000	143-1909-001		249-1522-010	249-1522-010
030-2273-000	030-2273-000	143-1910-000		249-1554-002	249-1554-002
030-2280-000	030-2280-000	143-1910-001	143-0000-077	249-1604-003	249-1604-003
030-2286-000	030-2286-000	143-1911-000		249-1604-004	249-1604-004
030-2356-000	030-2356-000	143-1911-001		249-2201-000	249-1521-002
030-2357-000	030-2357-000	143-1912-000		249-2202-000	249-1522-010
030-2358-000	030-2358-000	143-1912-001	143-0000-080	249-5027-013	249-5027-013
031-1113-009	031-1113-009	143-1913-000		249-5027-015	249-5027-007
031-1113-010	031-1113-010	143-1913-001		249-5027-016	249-5027-016
031-1287-000	031-1287-000	143-1958-000		320-0051-000	1250Y
031-1302-000	031-1302-000	143-1958-002	143-0000-079	320-1066-000	
031-1303-000	031-1303-000	143-1960-000		320-1066-001	
031-1308-000	031-1308-000	143-1960-002		320-1066-002	
031-1351-000		143-2015-000		320-1066-003	320-000-305
031-1351-001	031-0000-343	143-2015-001	143-0000-078	320-1066-004	
031-1351-002		143-2016-000		320-1066-005	
031-1351-003		143-2016-001		320-1066-006	
031-1352-000		143-2065-000		Dust Caps	
031-1252-000	031-0000-344	143-2066-000	1247Y	025-1121-001	
031-1252-002		143-2067-000		025-1122-001	025-0000-054
031-1352-003		143-2068-000		025-1123-001	(Conductive Only)
Replacement Coax Body Assembly		143-2085-000		025-1124-001	
021-0144-000	021-0144-000	143-2085-001	143-0000-079	025-1155-001	
021-0144-001	021-0144-001	143-2086-000		025-1156-001	025-0000-055
021-0144-002	021-0144-002	143-2086-001		025-1157-001	(Conductive Only)
021-0144-003	021-0144-003	Size #1 Coax Contacts		025-1158-001	
021-0144-004	021-0144-004	249-1521-000	249-1521-000	Filler Plugs	
021-0144-006	021-0144-006	249-1522-000	249-1522-000	225-0094-000	
021-0144-008	021-0144-008	249-1522-002	249-1522-002	225-0095-000	
021-0144-011	021-0144-011	249-1554-000	249-1554-000	225-0096-000	225-0000-014
Size #5 Coax Contacts		249-1604-000	249-1604-000	225-0097-000	
349-0013-000	349-0000-000	249-1604-001	249-1604-001	225-0098-000	
349-0014-000	349-0000-001	249-1604-002	249-1604-002	225-0098-000	
349-0015-000	349-0000-002	249-1882-000	249-1882-000	225-0099-000	
349-0016-000	349-0000-001	249-1882-002	1250Y	225-1058-000	
349-1003-000		249-1885-002		Sealing Plugs	
349-1009-000	349-000-301	249-5027-008	249-5027-008	225-0072-000	225-0000-006
Size #12 Shielded Contact		249-5027-017	249-5027-017	225-0090-000	225-0090-000
249-1767-000	249-1767-000	249-5123-000	249-5027-000	225-1013-000	
249-1767-001	249-1767-001	249-5123-001	249-5027-007	225-1014-000	225-0000-008
249-1768-000	249-1768-000	349-1053-000		225-1015-000	
249-2203-000	249-2203-000	349-1053-001		Replaceable Inserts	
Replaceable Inserts		349-1053-002		143-1906-000	
143-1906-000		349-1053-003		143-1906-001	143-0000-079
143-1906-001	143-0000-079	349-1053-004	349-0000-306	143-1907-001	
143-1907-001		3491053-005		143-1907-001	
143-1907-001		349-1053-006			
		349-1053-007			
		349-1053-008			
		349-1053-009			

For part numbers not listed, consult ITT for applicable customer-use drawing.

Dimensions shown in inch (mm)
 Specifications and dimensions subject to change

www.ittcannon.com



ARINC 600 Connector Engaging Sequence

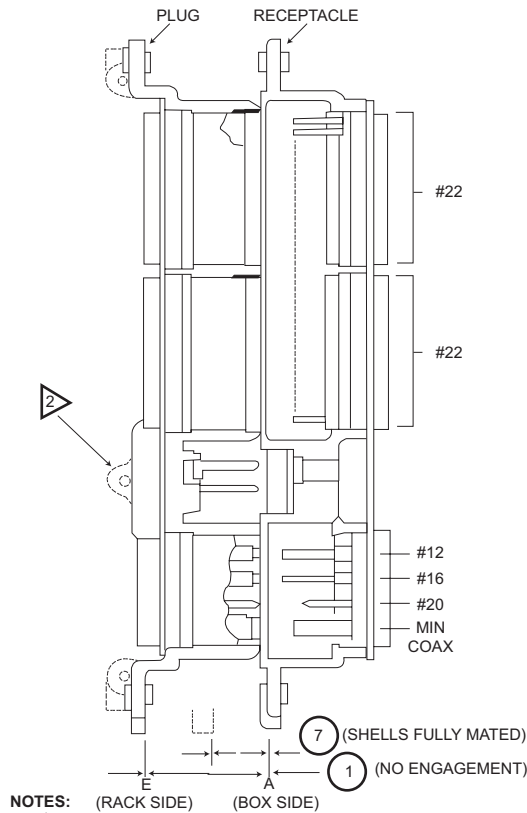

- NOTES:** (RACK SIDE) (BOX SIDE)
- 1. Varies; See Mil-Spec. (#5 Coax)
 - 2. Size 1 only.
 - 3. Flush head screws are not permitted for connector mounting as they would position connector incorrectly.
 - 4. Dimension 7 was calculated to provide clearance for
 - MCU backplate mat'l thickness of 2.5 mm (.10 in).
 - Rack backplate mat'l thickness of 2.5 mm (.10 in).
 - Connector mounting pan head screws, MCU 2.0 mm (.08 in).
 - Tolerance allowance - 3.2 mm (.13 in.) rack 2.0 mm (.08 in.)
 Total - 12.2 (.50 in) (minimum).

Mating Sequence	Flange Position With:	Flange Spacing in. (mm)
1	No Engagement	1.245 (31.62) Nom.
2	Shells Initially Engaged	1.110 (28.19) 1.073 (27.25)
3	Polarizing Pins Entering Keys	1.073 (27.25) 1.023 (25.88)
	Contacts Entering Mating Insulator	
	#22	.800 (22.32) .748 (18.99)
4	#20	.805 (20.44) .741 (18.82)
	#16	1.012 (25.70) .949 (24.10)
	#12	1.008 (23.60) .953 (24.20)
	Miniature Coax	1
	Contacts Electrically Engaged	
	#22	.642 (16.30) .547 (13.89)
	#20	.649 (16.48) .553 (14.04)
5	#16	.728 (18.49) .818 (20.77)
	#12	.772 (19.60) .692 (17.57)
	Miniature Coax	1
6	"0" Ring Engagement (BKAE Only)	.618 (15.70) .578 (14.68)
7	Shells Fully Mated	.522 (13.26) .488 (12.40)



- Available Rear Release/Rear Removable Front Release/Front Removable
- Low Insertion force contacts.
- Both environmental and non-environmental versions.
- Polarizing post that are removable from the mating face.
- Field replaceable inserts.
- Up to 150 Size #22 contacts per connector.
- Crimp, coax, twinax, printed circuit and wire wrappable post style contacts.
- Uses standard ARINC 600, crimp, insertion/ extraction tooling.



SGA connectors utilize all the Signal cavity inserts and contacts from the ARINC 600 connector series. It was designed to be used where there are space constraints in which a standard ARINC 600 connector can not be used. ITT's SGA connector fills the need for a 150 maximum contact connector with a smaller shell design than Shell Size 2 of ARINC 600, and has more contacts available than single gang DPX with 106 Size 22 contacts.

Materials and Finishes

		SGA*D	SGA*E	SGA*F	Specifications
Shell	Material	Aluminum alloy	Aluminum alloy	Aluminum alloy	QQ-A-591/A380
	Finish	Clear chromate over cadmium	Clear chromate over cadmium	Clear chromate over cadmium	QQ-P-416
Insulator	Material	Thermoplastic	Thermoplastic	Thermoset	N/A
	Material	Copper alloy	Copper alloy	Copper alloy	QQ-C-533
Contacts	Finish	Gold	Gold	Gold	MIL-G-45204
	Termination	Crimp	Crimp	P.C/Wrap Post	N/A
Grommets/Seals	Material	N/A	Silicone-based Elastomer	N/A	N/A
O-Ring	Material	N/A	Silicone-based Elastomer	N/A	N/A

How to Order (Refer to ARINC 600 [BKA] pages 12-14 for contact information.)

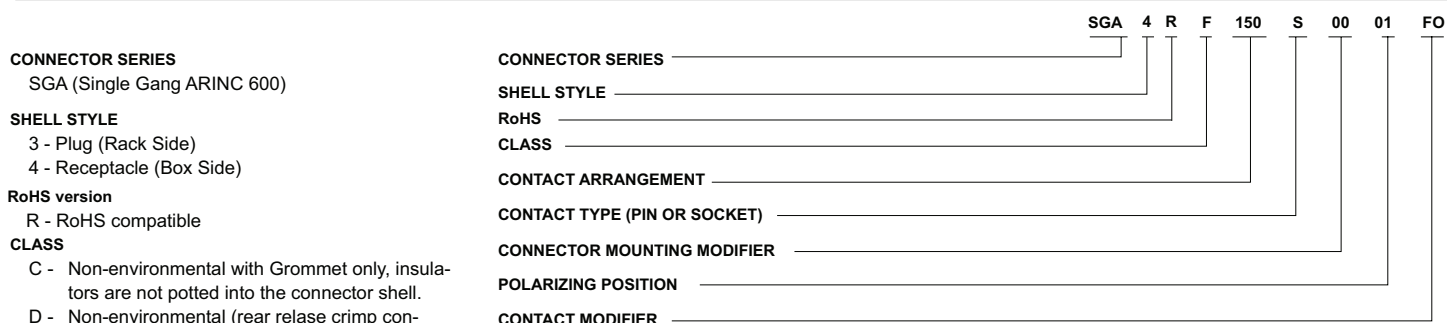

CONNECTOR SERIES
SGA (Single Gang ARINC 600)

SHELL STYLE
3 - Plug (Rack Side)
4 - Receptacle (Box Side)

RoHS version
R - RoHS compatible

CLASS
C - Non-environmental with Grommet only, insulators are not potted into the connector shell.
D - Non-environmental (rear release crimp contacts).
E - Environmentally sealed (rear release crimp contacts).
F - Non-environmental (front release, printed circuit or wire wrap posts).
R - EMI/RFI Protected & Environmentally sealed, 0-ring omitted (plug only). (Reference ITTC Phoenix)

CONTACT ARRANGEMENT
(See ARINC 600 (BKA) contact arrangements, pages 12-14)

CONTACT TYPE
P - Pin Contacts
S - Socket Contacts

CONNECTOR MOUNTING MODIFIER
Mounting modifiers 00, 03, 06, 14, 15, hole location is .705 basic from connector vertical centerline.
00 - .151 Dia. Mounting holes.
03 - .156 with #4-40 Self-Locking Clinch Nuts (ESNA #22NCFMA2-40) 4 per connector.
06 - .188 Dia. For #6-32 Clinch nuts (ESNA #12NCFMA2-62) 4 per connector.
14 - .137 Dia, Countersunk 82°x .230 Dia., Engaging face of mounting flange.
15 - .137 Dia, Countersunk 82° x .230 Dia., Engaging face of mounting flange. Supplied with slant shield grounding spring.

CONNECTOR SERIES

SHELL STYLE

RoHS

CLASS

CONTACT ARRANGEMENT

CONTACT TYPE (PIN OR SOCKET)

CONNECTOR MOUNTING MODIFIER

POLARIZING POSITION

CONTACT MODIFIER

Mounting modifiers 05, 07, 08, 09, 10, 11, 12, 13, hole location is .650 basic from connector vertical centerline.

- 05 - .208 Dia. for Floating Eyelet
- 07 - .212/.204 Slot 4 places.
- 08 - .120 Dia. Countersunk 82°x .230 Dia., Engaging face of mounting flange.
- 09 - .120 Dia. Countersunk 82°x .230 Dia., Rear face of mounting flange.
- 10 - .120 Dia. Countersunk 100°x .230 Dia., Engaging face of mounting flange.
- 11 - .120 Dia. Countersunk 100°x .230 Dia., Rear face of mounting flange.
- 14 - .137 Dia. Countersunk 82°x .230 Dia., Engaging face of mounting flange.
- 13 - .137 Dia. Countersunk 82°x .230 Dia., Rear face of mounting flange.

POLARIZING POSITION

01 - 36 Positions. (See Chart page 28)
When the last two digits are omitted, the polarizing posts will not be assembled and position number is not stamped on the connector. This allows the user to position the post and stamp the appropriate number on the shell. If the last two digits are "00", polarizing posts are not supplied with the connector.

CONTACT MODIFIER

Refer to page 17 for replacement contact part numbers and required termination tooling information. (Blank) - With standard Crimp type Rear release contacts.

- FO - Contacts are not supplied with connector (FO not stamped on connector.)
- SA - Front release .025 Dia. x .150 Solder Post Size 22 Sockets
- SB - Front release .025 Dia. x .250 Solder Post Size 22 Sockets
- SC - Front release .025 Dia. x .375 Solder Post Size 22 Sockets
- SD - Front release .025 Dia. x .500 Solder Post Size 22 Sockets
- WA - Front release .025 Sq. x .250 (1 Wrap)
- WB - Front release .025 Sq. x .375 (2 Wrap)
- WC - Front release .025 Sq. x .500 (3 Wrap)
- WD - Front release .025 Sq. x .641 (3 Wrap)



Plug Shell Dimensions

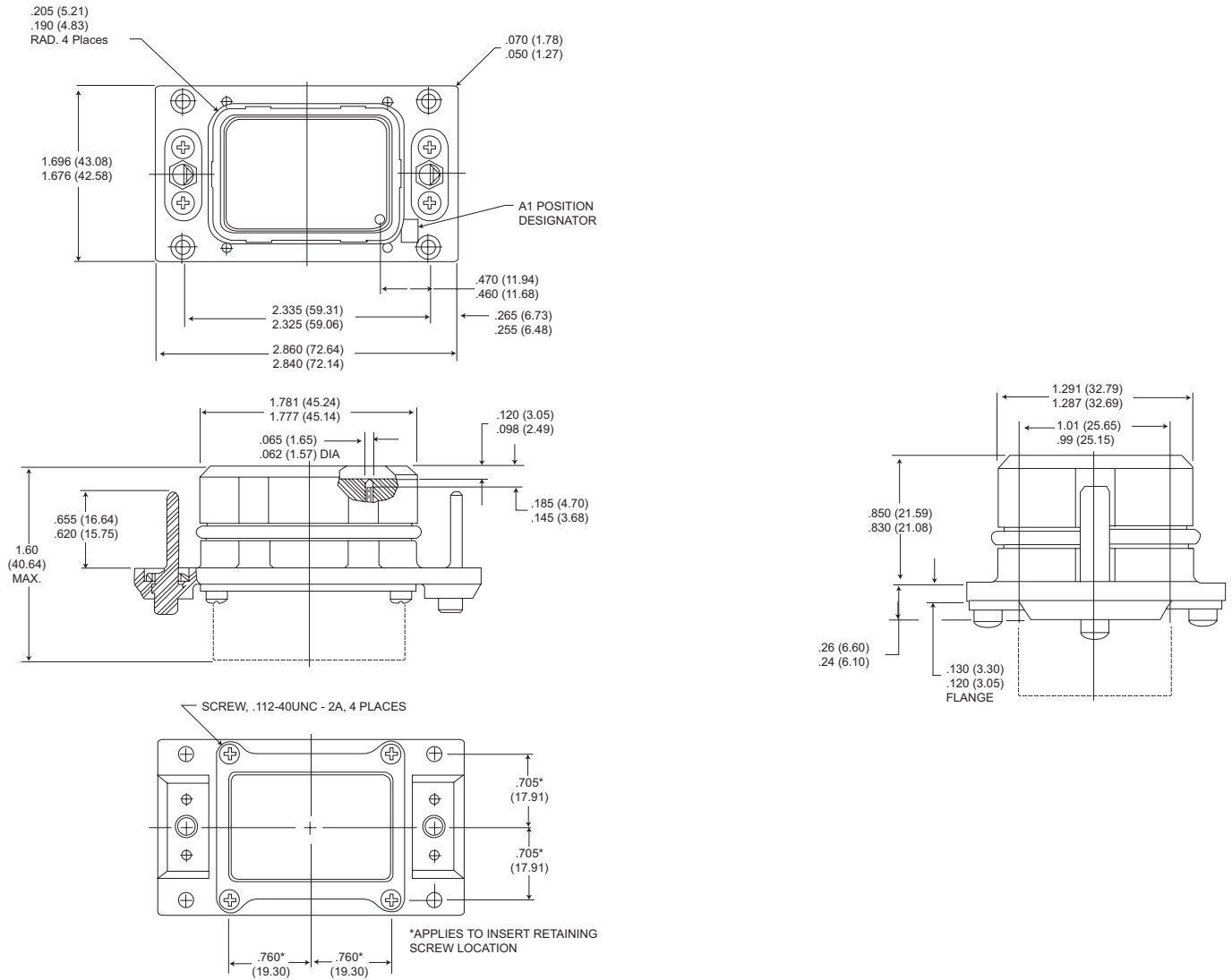

Recommended Panel Cutout

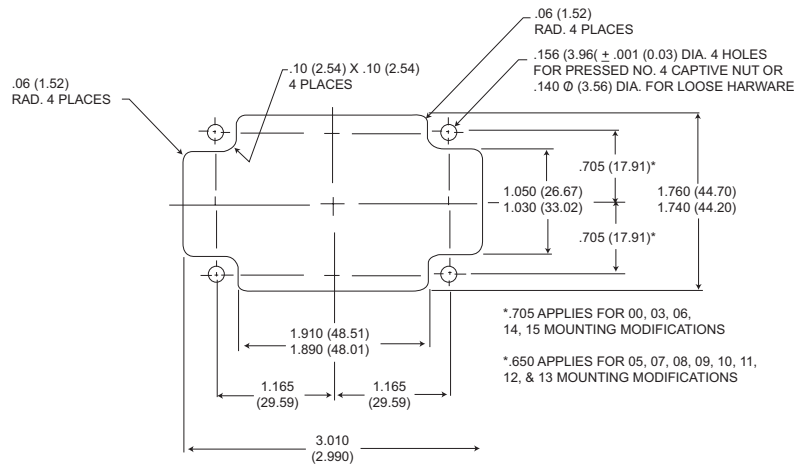

Receptacle Shell Dimensions

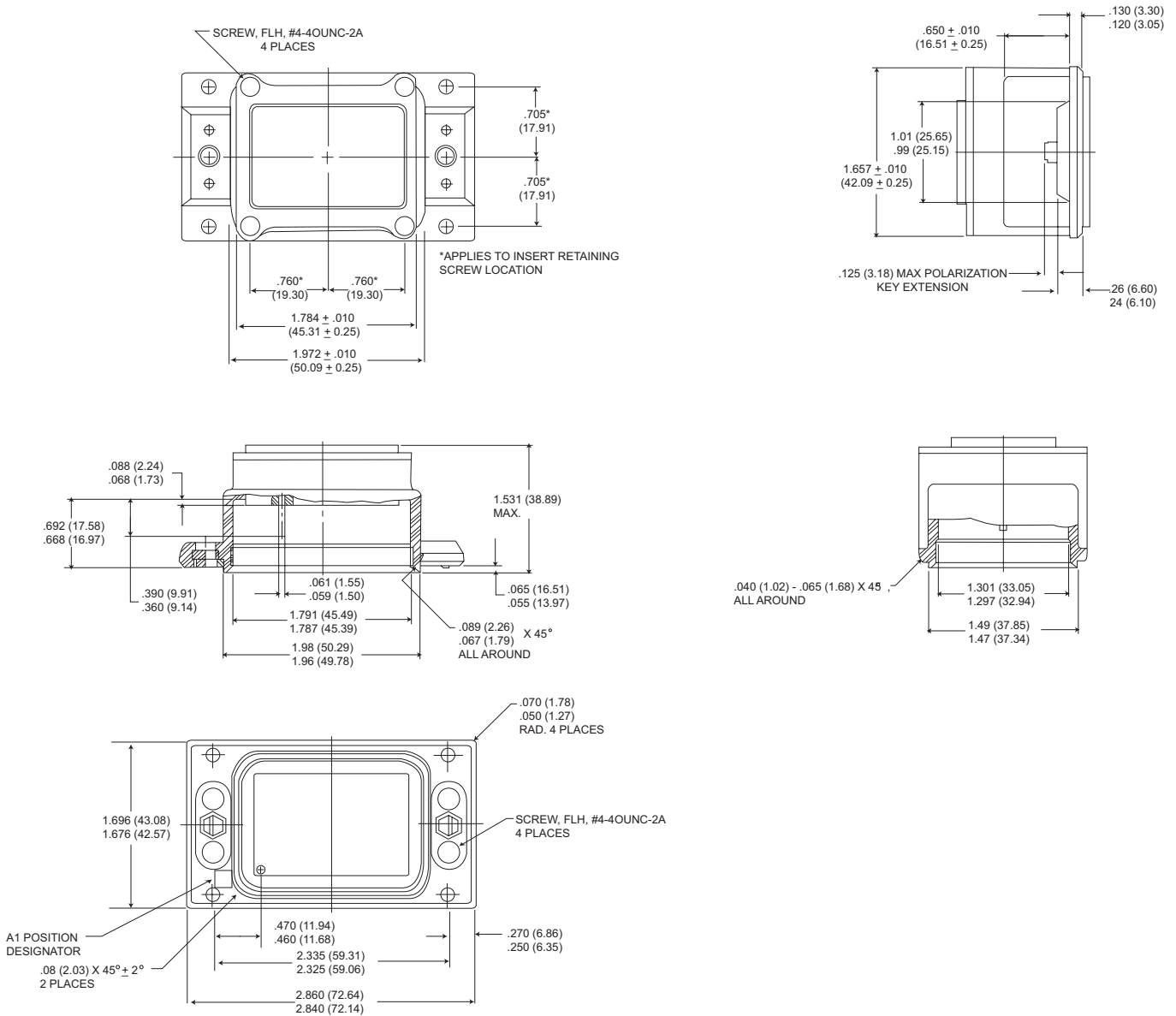

Recommended Panel Cutout

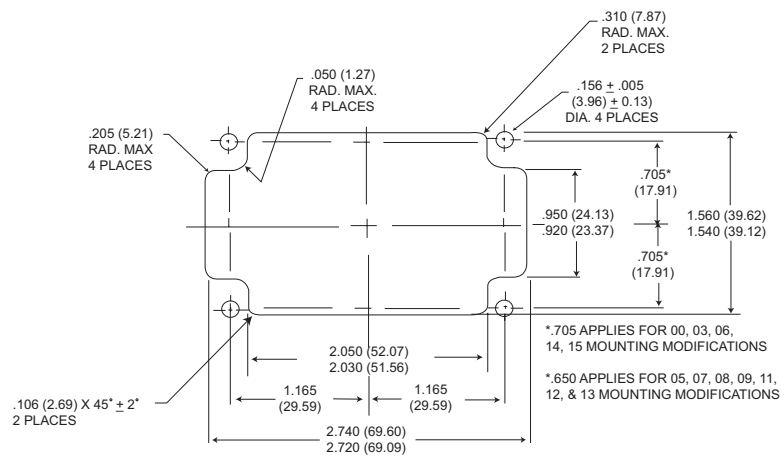

Dimensions shown in inch (mm)
Specifications and dimensions subject to change
www.ittcannon.com



Polarization

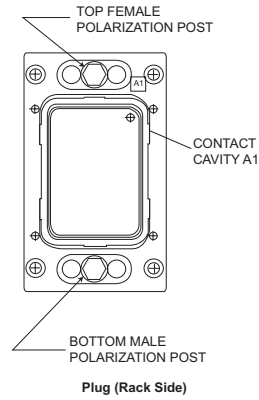
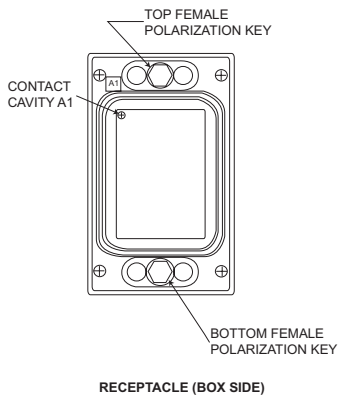

Polarizing Positions

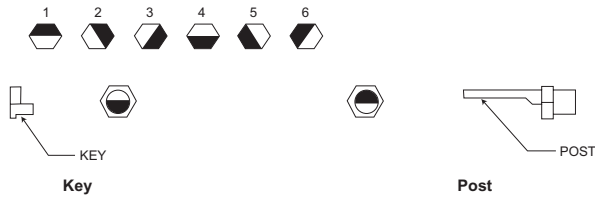

Position	Connector Receptacle		Connector Plug	
	Top Key	Bottom Key	Top Post	Bottom Post
01	1	1	4	4
02	3	4	2	1
03	2	4	3	1
04	1	4	4	1
05	6	4	5	1
06	5	4	6	1
07	4	5	1	6
08	3	5	2	6
09	2	5	3	6
10	1	5	4	6
11	6	5	5	6
12	5	5	6	6
13	4	6	1	5
14	3	6	2	5
15	2	6	3	5
16	1	6	4	5
17	6	6	5	5
18	5	6	6	5
19	4	1	1	4
20	3	1	2	4
21	2	1	3	4
22	4	4	1	1
23	6	1	5	4
24	5	1	6	4
25	4	2	1	3
26	3	2	2	3
27	2	2	3	3
28	1	2	4	3
29	6	2	5	3
30	5	2	6	3
31	4	3	1	2
32	3	3	2	2
33	2	3	3	2
34	1	3	4	2
35	6	3	5	2
36	5	3	6	2



Dimensions shown in inch (mm)
Specifications and dimensions subject to change

www.ittcannon.com



DPXNA (non-environmental, Type IV) and DPXNE (environmental, Types II and III) rack and panel connectors are designed to meet or exceed the requirements of MIL-C-81659, Revision B. They are used in military and aerospace applications and computer periphery equipment requirements, and are designed to operate in temperatures ranging from - 65°C to + 125°C. DPXNA/NE connectors are available in single, 2, 3, and 4 gang configurations

with a total of 12 contact arrangements accommodation contact sizes 12, 16, 20 and 22, and combination standard and coaxial contacts. Contact retention of these crimp snap-in contacts is provided by the LITTLE CAESAR® rear release contact retention assembly. Environmental sealing is accomplished by wire sealing grommets and interfacial seals.

Insert Designator Number

DPX3NA/DPX3NE										DPX4NA/DPX4NE											
MS3157	ITTC	Side A	Side B	Side C	MS3157	ITTC	Side A	Side B	Side C	MS3157	ITTC	Side A	Side B	Side C	Side D	MS3157	ITTC	Side A	Side B	Side C	Side D
0005	78M	26MP	26MP	26MP	0066	24M	W8MS	W8MS	W8MS	0007	104M	26MP	26MP	26MP	26MP	0063	95M	10W3MP	10W3MP	W8MP	67MP
0006	78M	26MS	26MS	26MS	0067	122M	W8MP	W8MP	A106S	0008	104M	26MS	26MS	26MS	26MS	0064	95M	10W3MS	10W3MS	W8MS	67MS
0013	120M	40MP	40MP	40MP	0068	122M	W8MS	W8MS	A106P	0015	160M	40MP	40MP	40MP	40MP	0085	150M	W8MP	W8MP	67MP	67MP
0014	120M	40MS	40MS	40MS	0073	142M	67MP	67MP	W8MP	0016	160M	40MS	40MS	40MS	40MS	0086	150M	W8MS	W8MS	67MS	67MS
0021	135M	45MP	45MP	45MP	0074	142M	67MS	67MS	W8MS	0023	180M	45MP	45MP	45MP	45MP	0095	326M	A106S	W8MP	A106S	A106S
0022	135M	45MS	45MS	45MS	0075	240M	67MP	67MP	A106S	0024	180M	45MS	45MS	45MS	45MS	0096	326M	A106P	W8MS	A106P	A106P
0029	171M	57MP	57MP	57MP	0076	240M	67MS	67MS	A106P	0031	228M	57MP	57MP	57MP	57MP	0097	287M	A106S	67MP	A106S	W8MP
0030	171M	57MS	57MS	57MS	0079	A240M	67MP	A106S	67MP	0032	228M	57MS	57MS	57MS	57MS	0098	287M	A106P	67MS	A106P	W8MS
0037	201M	67MP	67MP	67MP	0080	A240M	67MS	A106P	67MS	0039	268M	67MP	67MP	67MP	67MP	0099	189M	A106S	67MP	W8MP	W8MP
0038	201M	67MS	67MS	67MS	0091	279M	A106S	A106S	67MP	0040	268M	67MS	67MS	67MS	67MS	0100	189M	A106P	67MS	W8MS	W8MS
0045	A318	A106P	A106P	A106P	0092	279M	A106P	A106P	67MS	0047	A424	A106P	A106P	A106P	A106P	0101	346M	A106S	A106S	67MP	67MP
0046	A318	A106S	A106S	A106S	0157	244M	A106S	A106S	32W4MP	0048	A424	A106S	A106S	A106S	A106S	0102	346M	A106P	A106P	67MS	67MS
0065	24M	W8MP	W8MP	W8MP	0158	244M	A106P	A106P	32W4MS												

Performance and Material Specifications

MATERIALS AND FINISHES

Description	Material	Finish
Shell	Aluminum alloy	Cadmium plating, Type II, Class 3/ QQ-P-416 with yellow chromate finish (underplating may be used)
Insulators	Thermoplastic or thermosetting plastic	None
Elastomers	Silicone rubber (ITT Cannon Blend)	None
Contacts	Copper alloy	Gold plate per MIL-G-45204, Type 1, Grade C, Class 1 with suitable underplating (silver not used)
Insulator Retaining Plate	Aluminum alloy	Anodize, blue color
Junction Shells (Not available for four gang)	Aluminum alloy	Same as shell
Clinch Nuts	Stainless steel	Cadmium Plating
Float Mounts	Stainless Steel	None
Polarizing Posts	Zinc (die cast)	Cadmium plating
Polarizing Keys & Retaining Plate	Nickel Silver	None
Screws	Brass	Cadmium plating
Lockwashers	Phosphor Bronze	Cadmium plating

ELECTRICAL

Contact size	Wire Size	Insulation O.D. Limits (Inch)	Test Current per Mil-C-39029	Max. Current for Tests (Amps) (Mil-C-39029)	Max. Potential Drop (Millivolts) at 25°C
		Max.			
12	12	.135 (3.43)	23.0	23.0	63
	14		17.0	17.0	60
	16		13.0	13.0	68
16	18	.103 (2.62)	-	-	-
	20		7.5	-	75
	20		7.5	7.5	83
20	22	.071 (1.80)	-	-	-
	24		3.0	3.0	68
	22		5.0	5.0	110
22	24	.054 (1.37)	-	-	-
	26		2.0	2.0	80

Note - The maximum contact resistance listed above is with silver plated wire.

Dimensions shown in inch (mm)
Specifications and dimensions subject to change



How to Order

Single Gang

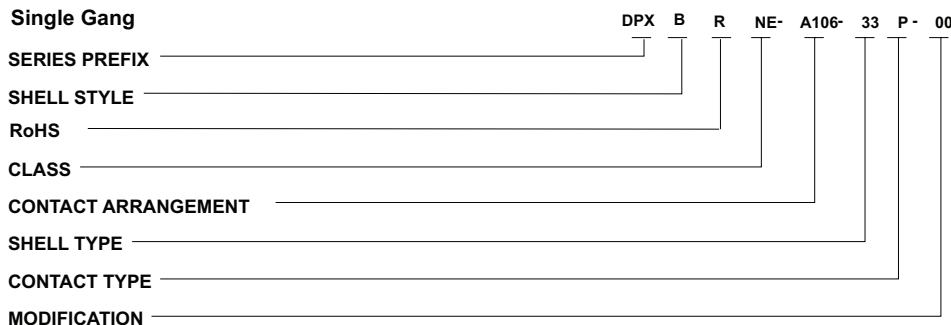

Two (2) Gang

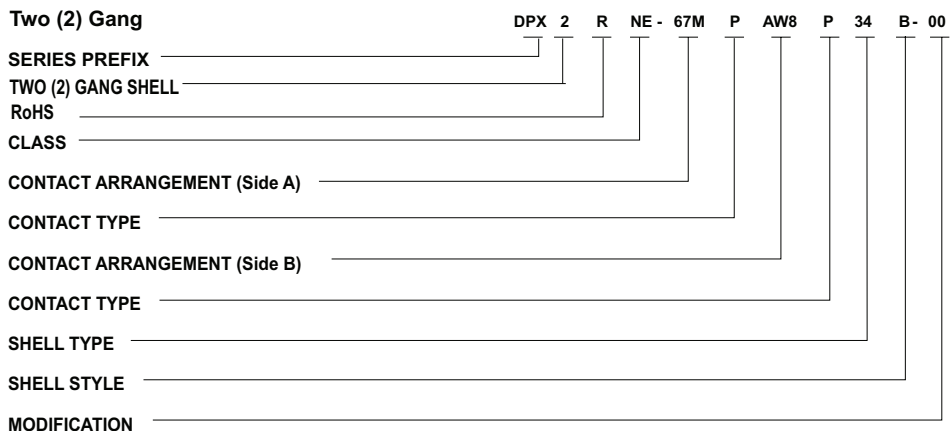

Three (3) Gang

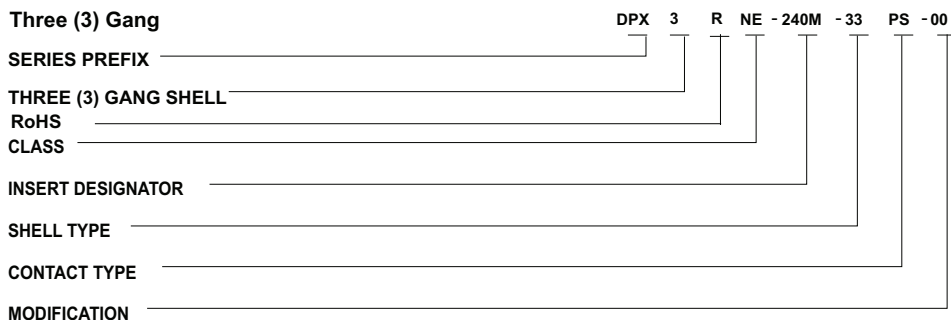

Four (4) Gang

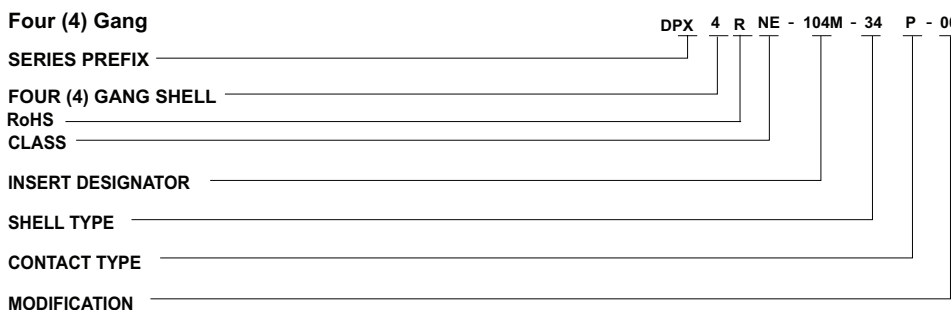

NOTE: On 3 & 4 gang assemblies, combination layouts, the contact type designator of the A106 layout. If applicable, precedes the 67 MS designator for standard contact sex layouts. See three (3) gang nomenclature breakdown above for 240M example (67MS A106P).

SERIES PREFIX

DPX - ITT Designation

SHELL STYLE

B - ARINC 'B' Shell

RoHS version

R - RoHS compatible

CLASS (MIL-C-81659B, Class 1)....

NA - Non - Environmental (MIL-C-81659B, Type IV)

NE - Environmental (Mil-C-81659B, Types II and III)

INSERT DESIGNATOR

In the 3 and 4 gang assemblies, the insert designation number represents cumulative (total) contacts. The charts on page 30 denote shell cavity location by layout. (If desired arrangement location is not defined, please consult or local sales engineering office.)

CONTACT ARRANGEMENT

See page 35

SHELL TYPE

'33' for Plug; '34' for Receptacle

CONTACT TYPE

'P' for Pin (Standard on '34' receptacle except A106 layout which has reversed contact sex)
'S' for Socket (Standard on '33' plug except A106 layout which has reversed contact sex)

MODIFICATION CODES

- 00 Standard
- 01 Standard with clinch nuts in the mounting holes.
- 02 Standard with tabs for attaching junction shells.
- 03 Standard with mounting holes .120 dia. countersunk 100° to .230 dia.
- 17 Combination of 01** and 02** (clinch nuts in mounting holes - 34 only and tabs for attaching junction shells).
- 22 Standard with clinch nuts (.33 only).
- 23 Standard with standard floating eyelets.
- 29 Standard except less grommet (NE, pin only).
- 30 Same as - 29** except with tabs for attaching junction shells.
- 33 Same as - 29** except with clinch nuts.
- 37 Same as - 29** except with clinch nuts and tabs for attaching junction shells.
- 39 Standard with standard floating eyelets and tabs for attaching junction shells.

NOTE: For additional modification codes please consult Customer Service.



Dimensions shown in inch (mm)
Specifications and dimensions subject to change

www.ittcannon.com

Shell Dimensions

DPXB-33

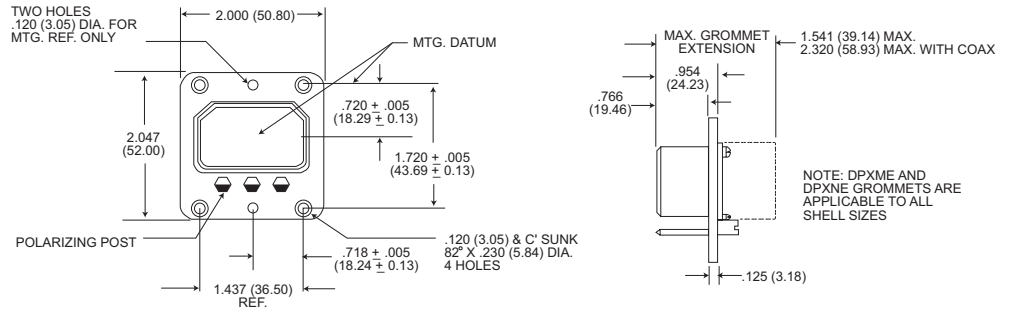

DPXB-34

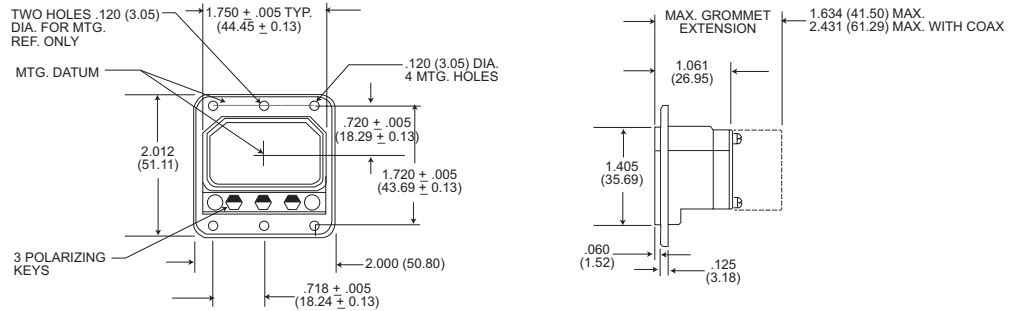

DPX2-33B

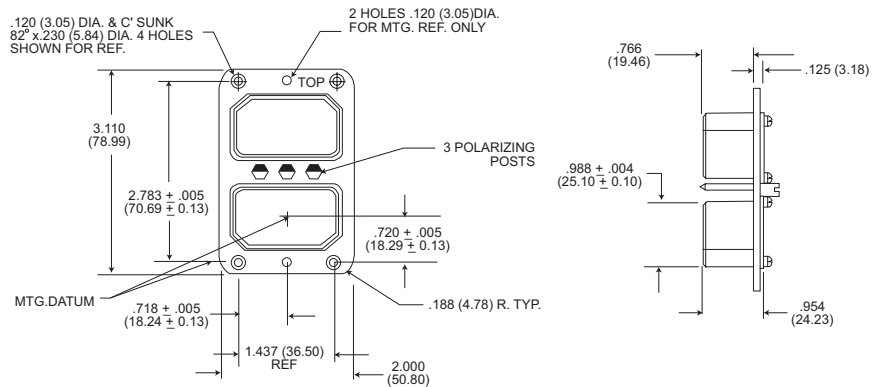

DPX2-34B

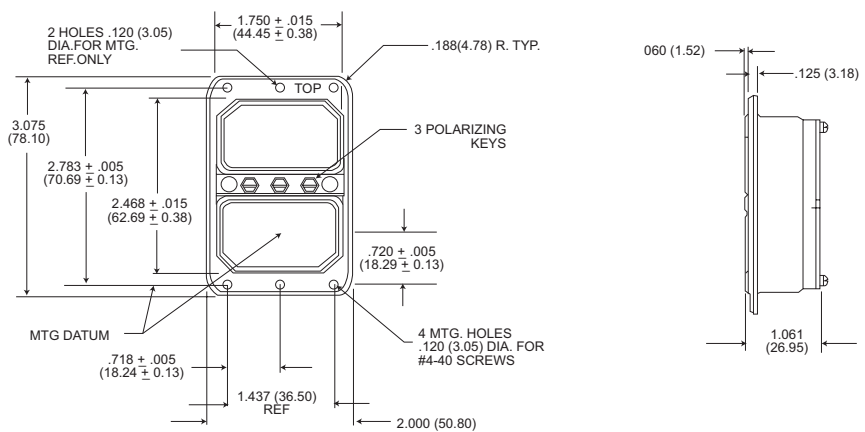

All tolerances ± .015 (0.38) unless otherwise noted.

Shell Dimensions

DPX3-33

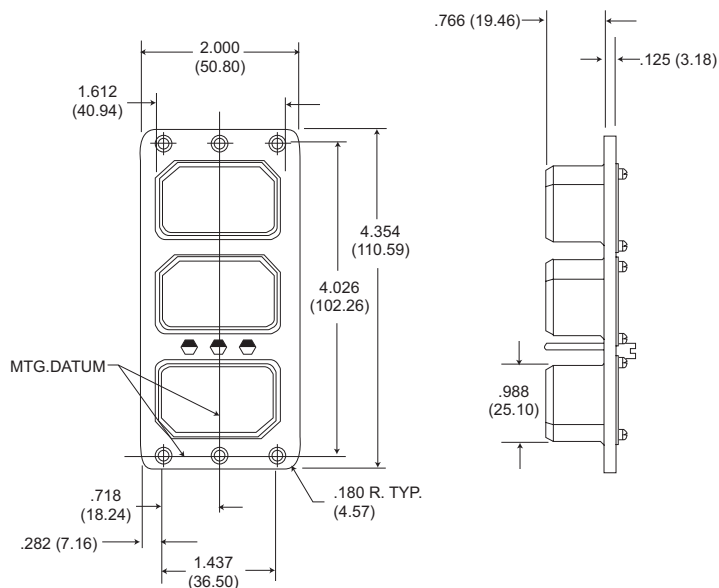

DPX3-34

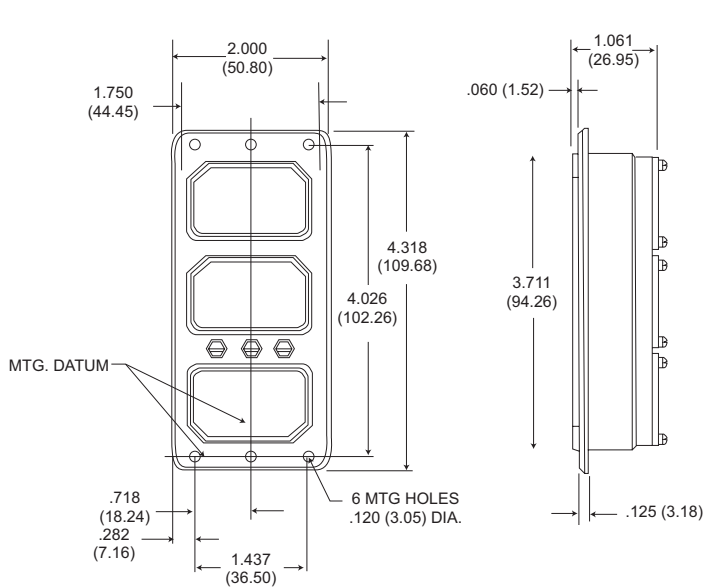

DPX4-33

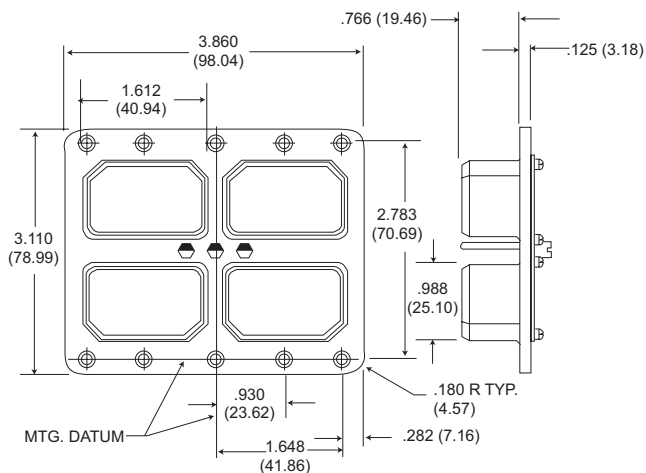

DPX4-34

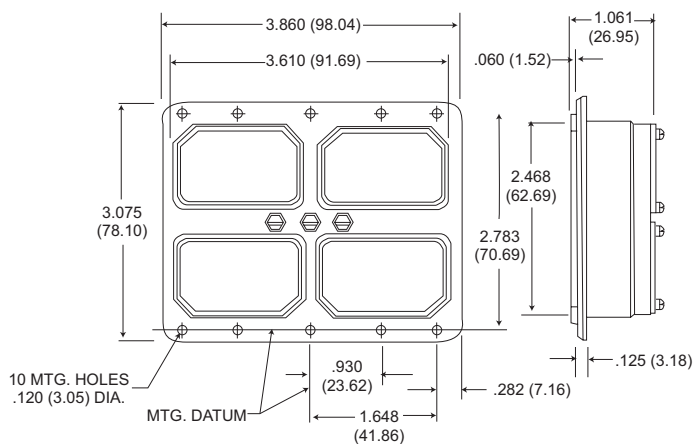

Modification Code

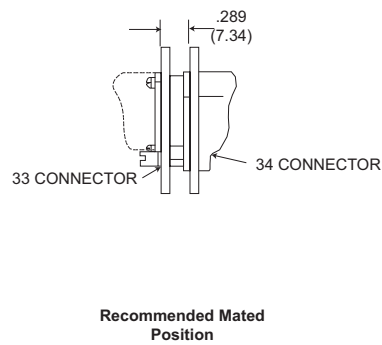
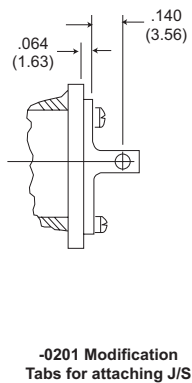
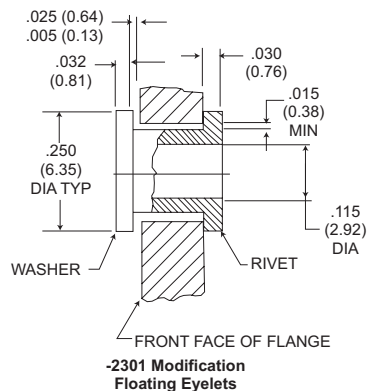

All tolerances $\pm .015$ (0.38) unless otherwise noted.
Dimensions shown in inch (mm)

Specifications and dimensions subject to change

www.ittcannon.com



Panel Cutouts

DPXB

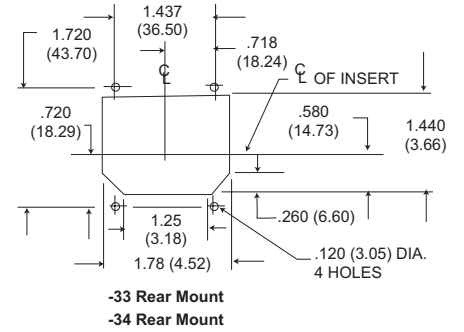
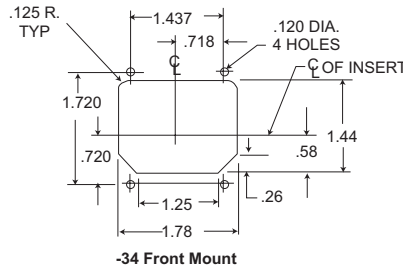
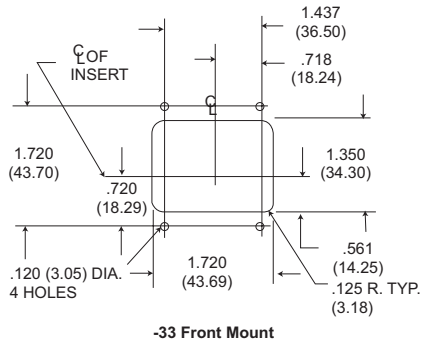

DPX2

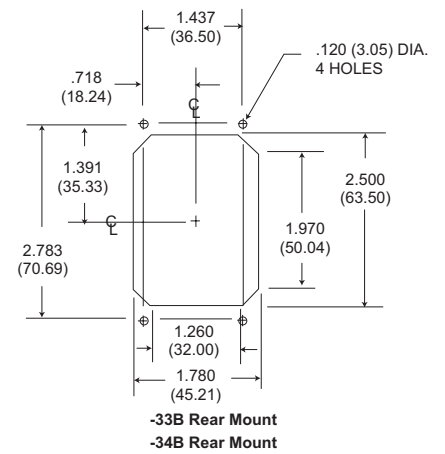
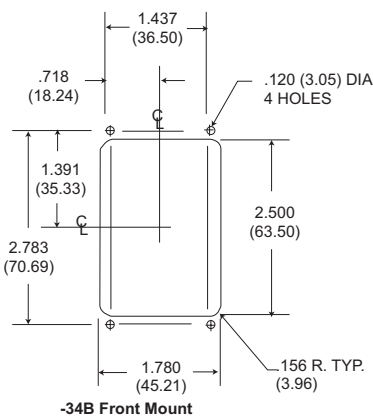
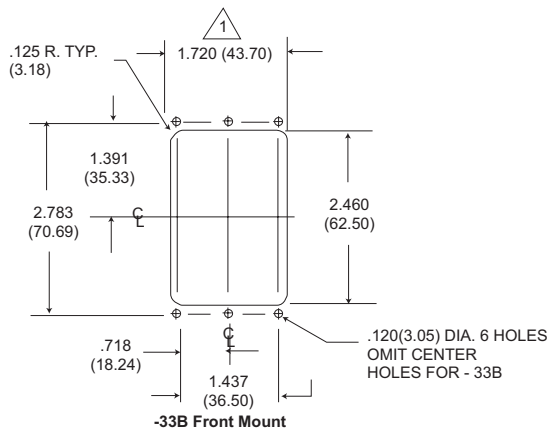

△ For - 23 float mtg. mod. 1.78 (45.21)

DPX3

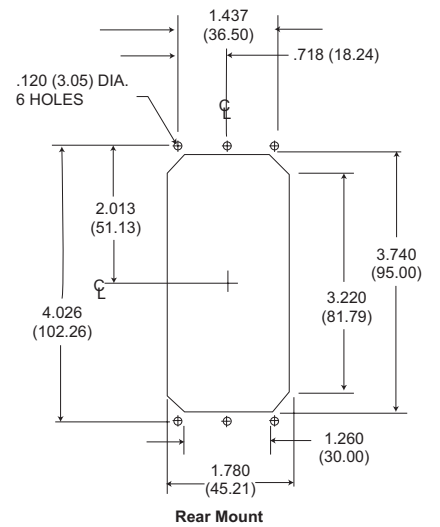
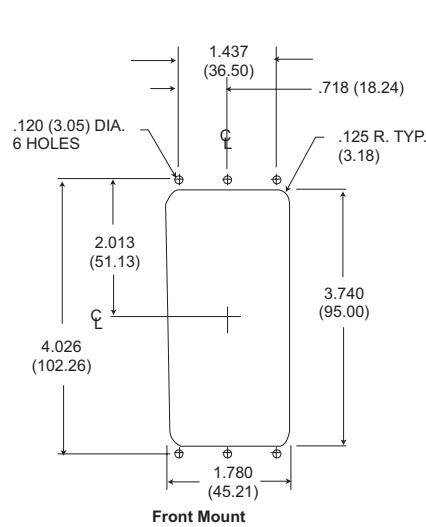

All tolerance $\pm .015$ (0.38) unless other wise noted.

Panel Cutouts

DPX4

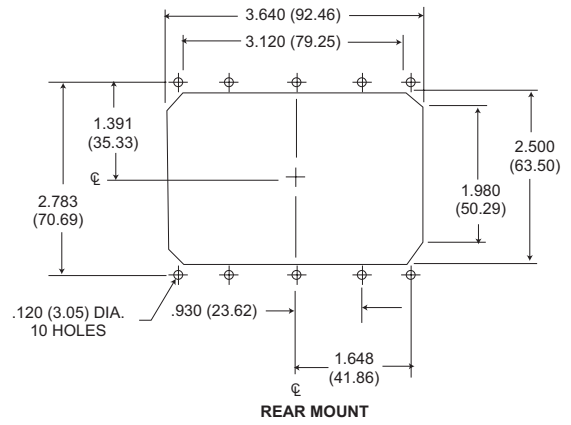
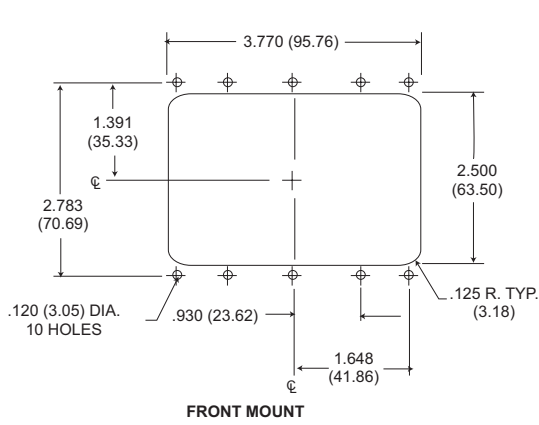

All tolerance $\pm .015$ (0.38) unless otherwise noted.

Contact Arrangement

Face View of Pin Insulator Shown.

Cross Reference

MS3157	ITTC
C8	W8M
E8	D8M
10C3	10W3M
26	26M
32C2	32W2M
32C4	32W4M
	33C4M
40	40M
40C1	40W1M
45	45M
57	57M
67	67M
106	A106

Layout
Contacts
Test Voltage

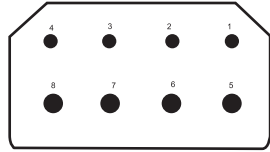

D8M
4 #16, 4 #12
1500

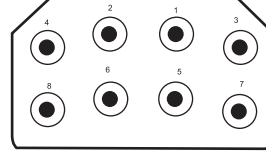

W8M
8 Coaxial*
1000

Layout
Contacts
Test Voltage

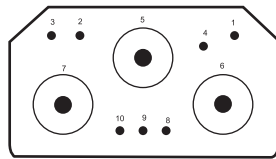

10W3M
7HD #20, 3 Coaxial**
1500
(Coax 1000)

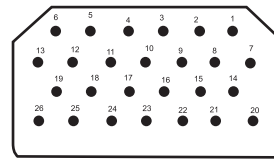

26M
26 #16
1500

Layout
Contacts
Test Voltage

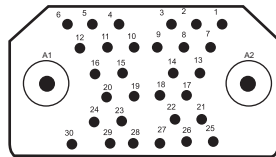

32W2M
30HD #20, 2 Coaxial†
1500
(Coax 1000)

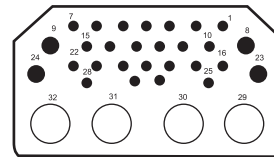

32W4M
24HD #20
4 #16, 4 Coaxial*
1500
(Coax 1000)

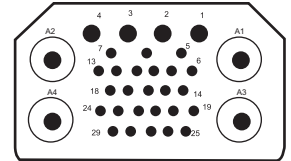

33C4M
25HD #20, 4 Coaxial†, 4 #16
1000

Layout
Contacts
Test Voltage

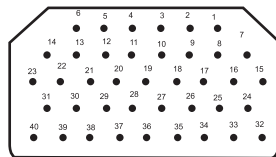

40M
40HD #20
1500

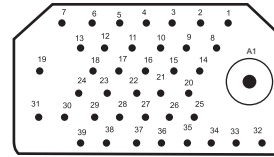

40W1M
39HD #20, 1 COAXIAL†
1500
(COAX 1000)

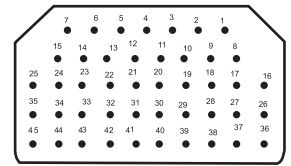

45M
45HD #20
1500

Layout
Contacts
Test Voltage

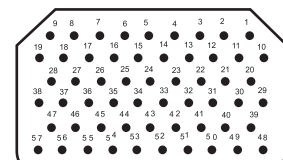

57M
57 HD #20
1500

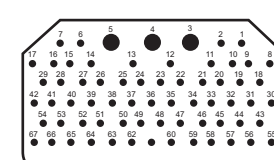

67M
64 HD #20, 3 #16
1000

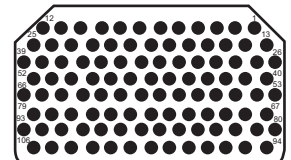

A106
106 #22
1000

*SIZE 9 COAXIAL **SIZE 11 COAXIAL † SIZE 5 COAXIAL

NOTE: All coaxial layouts supplied less coaxial contacts (i.e. W8M, 10W3M, 32W2M, 32W4M, 33C4M, 36W7, 40W1M)

Dimensions shown in inch (mm)
Specifications and dimensions subject to change

www.ittcannon.com



Contact and Termination Tooling Data - Military

Contact Size	DPX*NE/NA		Wire Accom.	Crimp Tool Part Number	Locator Part Number	Insertion/Extraction Tool	Layout Usage DPX*NE/NA
	Pin Part Number (Military Equivalent)	Socket Part Number (Military Equivalent)					
2222	030-1975-008 (M39029/11-144)	031-1113-008 (M39029/12-148)	22, 24, 26	M22520/2-01	M22520/2-23	CIT-DPXMA-22 M81969/1-01	A106
2020HD	030-1892-004 (M39029/11-145)	031-1047-003 (M39029/12-149)	20, 22, 24	M22520/2-01 MS-3191-1	M22520/2-08 Standard	CIT-20 CET-20D-1 M81969/1-02	10W3M, 32W2M, 32W4M, 40M, 40W1M, 45M, 57M, 67M,
1616	030-9083-012 (M39029/11-146)	031-1271-000 (M39029/12-150)	16, 18, 20	M22520/1-01 MS-3191-1	M22520/1-02 Std. Locator	CIET-16	D8M, 26M, 32W4M, 67M
1212	030-1909-002 (M39029/11-147)	031-1059-003 (M39029/12-151)	12, 14	M22520/1-01	M22520/1-11	CIET-12	D8M

*Requires air line pressure of 80 to 100 PSI for CBT-600 and 120 PSI for CBT-600B.

Coaxial Contact Data

Components/Accessories

LITTLE CAESAR® contact retention assembly (W8M, 32W2M, 32W4M & 40W1M contact arrangements)

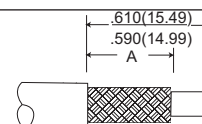

Contact Arrangement	Part Number (P=Pin, S = Socket)			Cable Accommodation†		Ins. Dia. Size/Max.	'A' Trim Dim.	
	Without Seal††		With Seal	Seal 1	Seal 2			
	A152†††	A176†††	A152†††					
(Size 5 Coax)	P-249-2071-000	249-2071-001	249-2101-000	RG180	RG195U	.158 (4.01)	.260(6.60)	
	S-249-2076-000	249-2076-001	249-2106-000				.250(6.35)	
	P-249-2072-000	249-2072-001	249-2102-000	RG58	X	.196 (4.98)	.260(6.60)	
	S-249-2077-000	249-2077-001	249-2107-000				.250(6.35)	
	32W2M	P-249-2073-000	249-2073-001	249-2103-000	RG142	X	.196 (4.98)	.260(6.60)
		S-249-2078-000	249-2078-001	249-2108-000				.250(6.35)
	40W1M	P-249-2074-000	249-2074-001	249-2104-000	RG179	RG174, RG179,	.111 (2.82)	.350(8.89)
		S-249-2079-000	249-2079-001	249-2109-000		RG316		.330(8.38)
	36W7	P-249-2075-000	249-2075-001	249-2105-000	RG178	X	.075 (1.90)	.260(6.60)
		S-249-2080-000	249-2080-001	249-2110-000	RG196			.250(6.35)
(Size 9 Coax)	P-249-2081-000	249-2081-001	249-2111-000	RG180	RG195U	.158 (4.01)	.260(6.60)	
	S-249-2086-000	249-2086-001	249-2116-000				.250(6.35)	
	P-249-2082-000	249-2082-001	249-2112-000	RG58	X	.196 (4.98)	.260(6.60)	
	S-249-2087-000	249-2087-001	249-2117-000				.250(6.35)	
	W8M	P-249-2083-000	249-2083-001	249-2113-000	RG142	X	.196 (4.98)	.260(6.60)
		S-249-2088-000	249-2088-001	249-2118-000				.250(6.35)
	32W4M	P-249-2084-000	249-2084-001	249-2114-000	RG179	RG174, RG179,	.111 (2.82)	.350(8.89)
		S-249-2089-000	249-2089-001	249-2119-000		RG316		.330(8.38)
	P-249-2085-000	249-2085-001	249-2115-000	RG178U	X	.075 (1.90)	.260(6.60)	
	S-249-2090-000	249-2090-001	249-2120-000	RG196U			.250(6.35)	

NOTES: † Coaxials without the seal accommodates both Seal 1 and Seal 2 cables.
 †† Coaxials without the seal are utilized in DPX*NE connectors supplied less the grommet (modification code: - 29**) and DPX*NA connectors.
 ††† A152 modification code indicates .00005 (0.0010) gold plating on coaxial contacts. (Standard for the DPXNE/NA series.)
 A176 modification code indicates .00002 (0.0005) gold plating on coaxial contacts.

Wire Strip Dimensions



Wire Strip Dimension	
A Dim.	
#22	.130/.110(3.30/2.79)



Dimensions shown in inch (mm)
 Specifications and dimensions subject to change

www.ittcannon.com

Coaxial Contact Data

Installation Data

1. Use basic tool M22520/5-01 with Y-211 die (#995-0002-249) for crimping.
2. Use extraction tool No. CET-C8. An insertion tool is not required (See Note 5).
3. Center contact, rear insulator, crimp ring, support bushing (not applicable to RG58/RG142 coaxials), seal sleeve, front insulator, shell and ferrule are shipped unassembled in a common container.

4. Cable Assembly Instructions

- Step 1 - If applicable determine which portion of seal sleeve should be used. If Seal 2 is used, cut off Seal 1 portion.
- Step 2 - In sequence, place seal sleeve, support bushing and crimp ring over cable jacket.
- Step 3 - Trim cable per illustration.
- Step 4 - Comb out braid and flare out ends to permit entry of ferrule.
- Step 5 - Complete termination per illustration.

5. To extract coaxial, push back seal sleeve and support bushing. Slip cable into extraction tool. Push tool into insert until contacts coaxial retaining shoulder. Grip both cable and tool with one hand and pull coaxial rearward out of insert cavity.
6. To facilitate extraction of contacts, the length of free cable adjacent to the rear surface of the connector should not be less than 2.000 (50.80).

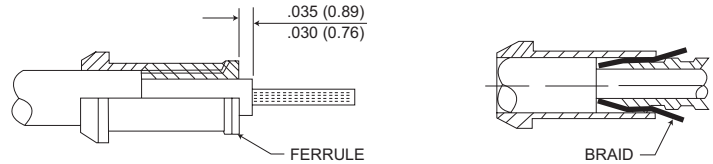
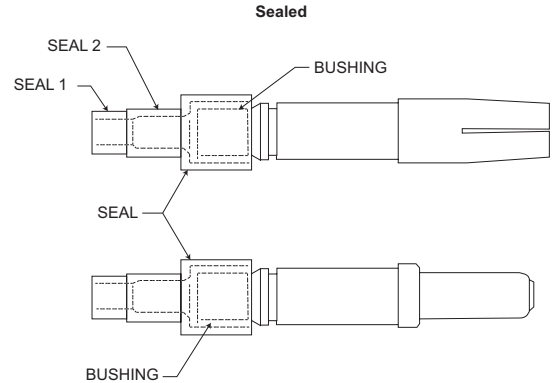
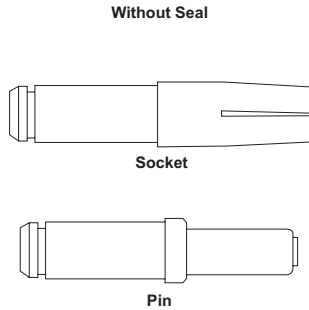

- A. Push ferrule under braid as far as it will go. Trim off braid extending beyond shoulder of ferrule, if necessary.
- B. While holding ferrule in place pull crimp sleeve forward over braid until it is tight against shoulder on ferrule. Pull firmly against face of ferrule to make sure it is up tight.
- C. Trim dielectric to the .035 (0.89)/.030 (0.76) dimension.

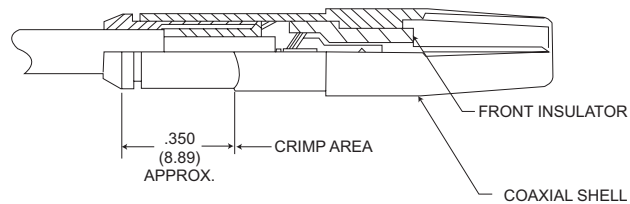

- A. Place front insulator over contact and then push assembly into coaxial shell.
- B. Place parts in jaw of crimp tool. Locate jaws at start of chamber on crimp sleeve. Press sleeve firmly into coaxial shell and crimp.
- C. After assembled coaxial is inserted into connector, push support bushing into grommet until shoulder rests on tubular extension. Then pull sealing sleeve forward until it is snug on grommet.

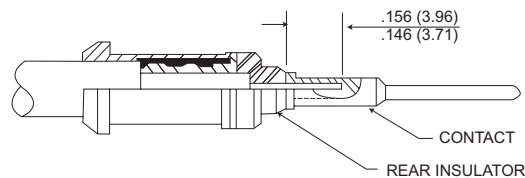

- A. Carefully push inner conductor through rear insulator.
- B. While holding rear insulator firmly against ferrule, trim conductor to .156 (3.96)/.146 (3.91) dimension.
- C. Place contact over conductor and solder.

Dimensions shown in inch (mm)
Specifications and dimensions subject to change

www.ittcannon.com



Polarization Positions

MIL-C-81659B requires that polarizing post be shipped unassembled with the connector. The user then assembles the post in the preferred position and marks the position number on the connector. All DPXNA and DPXNE connectors shall be sold this way. The position number will not be marked.



Face View of Engaging End

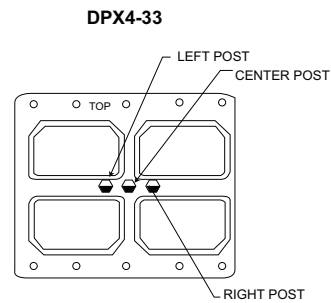
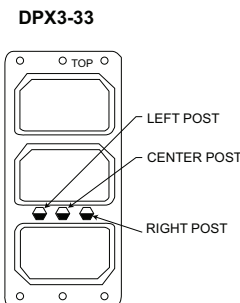
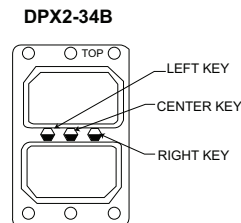
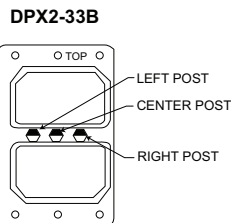
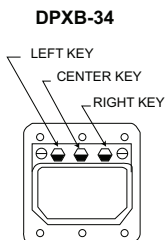
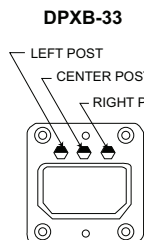

The last two digits in the four-digit dash number refer to the polarizing post position. The polarizing posts will be shipped unassembled with the connector assembly. The position number is not stamped on the connector. This allows the customer to position the posts themselves and then stamp the appropriate number on the shell.

33 PLUG MALE SHELL					34 RECEPTACLE FEMALE SHELL										
Position	Left Post	Center Post	Right Post	Position	Left Post	Center Post	Right Post	Position	Left Post	Center Post	Right Post	Position	Left Post	Center Post	Right Post
01	1	1	1	51	3	2	5	01	4	4	4	51	6	3	2
02	2	1	1	52	4	2	5	02	4	4	3	52	6	3	1
03	3	1	1	53	5	2	5	03	4	4	2	53	6	3	6
04	4	1	1	54	6	2	5	04	4	4	1	54	6	3	5
05	5	1	1	55	1	2	4	05	4	4	6	55	1	3	4
06	6	1	1	56	2	2	4	06	4	4	5	56	1	3	3
07	1	1	6	57	3	2	4	07	5	4	4	57	1	3	2
08	2	1	6	58	4	2	4	08	5	4	3	58	1	3	1
09	3	1	6	59	5	2	4	09	5	4	2	59	1	3	6
10	4	1	6	60	6	2	4	10	5	4	1	60	1	3	5
11	5	1	6	61	1	2	3	11	5	4	6	61	2	3	4
12	6	1	6	62	2	2	3	12	5	4	5	62	2	3	3
13	1	1	5	63	3	2	3	13	6	4	4	63	2	3	2
14	2	1	5	64	4	2	3	14	6	4	3	64	2	3	1
15	3	1	5	65	5	2	3	15	6	4	2	65	2	3	6
16	4	1	5	66	6	2	3	16	6	4	1	66	2	3	5
17	5	1	5	67	1	2	2	17	6	4	6	67	3	3	4
18	6	1	5	68	2	2	2	18	6	4	5	68	3	3	3
19	1	1	4	69	3	2	2	19	1	4	4	69	3	3	2
20	2	1	4	70	4	2	2	20	1	4	3	70	3	3	1
21	3	1	4	71	5	2	2	21	1	4	2	71	3	3	6
22	4	1	4	72	6	2	2	22	1	4	1	72	3	3	5
23	5	1	4	73	1	3	1	23	1	4	6	73	4	2	4
24	6	1	4	74	2	3	1	24	1	4	5	74	4	2	3
25	1	1	3	75	3	3	1	25	2	4	4	75	4	2	2
26	2	1	3	76	4	3	1	26	2	4	3	76	4	2	1
27	3	1	3	77	5	3	1	27	2	4	2	77	4	2	6
28	4	1	3	78	6	3	1	28	2	4	1	78	4	2	5
29	5	1	3	79	1	3	6	29	2	4	6	79	5	2	4
30	6	1	3	80	2	3	6	30	2	4	5	80	5	2	3
31	1	1	2	81	3	3	6	31	3	4	4	81	5	2	2
32	2	1	2	82	4	3	6	32	3	4	3	82	5	2	1
33	3	1	2	83	5	3	6	33	3	4	2	83	5	2	6
34	4	1	2	84	6	3	6	34	3	4	1	84	5	2	5
35	5	1	2	85	1	3	5	35	3	4	6	85	6	2	4
36	6	1	2	86	2	3	5	36	3	4	5	86	6	2	3
37	1	2	1	87	3	3	5	37	4	3	4	87	6	2	2
38	2	2	1	88	4	3	5	38	4	3	3	88	6	2	1
39	3	2	1	89	5	3	5	39	4	3	2	89	6	2	6
40	4	2	1	90	6	3	5	40	4	3	1	90	6	2	5
41	5	2	1	91	3	3	4	41	4	3	6	91	1	2	4
42	6	2	1	92	2	3	4	42	4	3	5	92	1	2	3
43	1	2	6	93	3	3	4	43	5	3	4	93	1	2	2
44	2	2	6	94	4	3	4	44	5	3	3	94	1	2	1
45	3	2	6	95	5	3	4	45	5	3	2	95	1	2	6
46	4	2	6	96	6	3	4	46	5	3	1	96	1	2	5
47	5	2	6	97	1	3	3	47	5	3	6	97	2	2	4
48	6	2	6	98	2	3	3	48	5	3	5	98	2	2	3
49	1	2	5	99	3	3	3	49	6	3	4	99	2	2	2
50	2	2	5					50	6	3	3				

Dimensions shown in inch (mm)

Specifications and dimensions subject to change

www.ittcannon.com



Cross Reference from Military to Cannon Part Numbers

Military Part Number	Cannon Part Number	Military Part Number	Cannon Part Number	Military Part Number	Cannon Part Number
M81659/29A2-0001	DPXBNE-26M-33P-00	M81659/33A2-0122	DPX2NE-32W2MS40W1MS-33B-00	M81659/37A2-0005	DPX3NE-78M-33P-00
0002	DPXBNE-26M-33S-00	0123	DPX2NE-32WMP45MP-33B-00	0006	DPX3NE-78M-33S-00
0009	DPXBNE-40M-33P-00	0124	DPX2NE-32W2MS45MS-33B-00	0013	DPX3NE-120M-33P-00
0010	DPXBNE-40M-33S-00	0125	DPX2NE-32W2MP57MP-33B-00	0014	DPX3NE-120M-33S-00
0017	DPXBNE-45M-33P-00	0126	DPX2NE-32W2MS57MS-33B-00	0021	DPX3NE-135M-33P-00
0018	DPXBNE-45M-33S-00	0127	DPX2NE-32W2MP67MP-33B-00	0022	DPX3NE-135M-33S-00
0025	DPXBNE-57M-33P-00	0128	DPX2NE-32W2MS67MS-33B-00	0029	DPX3NE-171M-33P-00
0026	DPXBNE-57M-33S-00	0129	DPX2NE-32W2MPA106S-33B-00	0030	DPX3NE-171M-33S-00
0033	DPXBNE-67M-33P-00	0130	DPX2NE-32W2MSA106P-33B-00	0037	DPX3NE-201M-33P-00
0034	DPXBNE-67M-33S-00	0131	DPX2NE-40W1MP40W1MP-33B-00	0038	DPX3NE-201M-33S-00
0041	DPXBNE-A106-33P-00	0132	DPX2NE-40W1MS40W1MS-33N-00	0045	DPX3NE-A318-33P-00
0042	DPXBNE-A106-33S-00	0133	DPX2NE-57MPA106S-33B-00	0046	DPX3NE-A318-33S-00
0083	DPXBNE-D8M-33P-00	0134	DPX2NE-57MSA106P-33B-00	0065	DPX3NE-24M-33P-00
0084	DPXBNE-D8M-33S-00	0145	DPX2NE-W8MP57MP-33B-00	0066	DPX3NE-24M-33S-00
0135	DPXBNE-W8M-33P-00	0146	DPX2NE-W8MS57MS-33B-00	0067	DPX3NE-122M-33SP-00
0136	DPXBNE-W8M-33S-00	0147	DPX2NE-57MP26MP-33B-00	0068	DPX3NE-122M-33PS-00
0137	DPXBNE-10W3M-33P-00	0148	DPX2NE-57MS25MS-33B-00	0073	DPX3NE-142M-33P-00
0138	DPXBNE-10W3M-33S-00	0151	DPX2NE-32W4MPA106S-33B-00	0074	DPX3NE-142M-33S-00
0139	DPXBNE-32W2M-33P-00	0152	DPX2NE-32W4MSA106P-33B-00	0075	DPX3NE-240M-33P-00
0140	DPXBNE-32W2M-33S-00	0155	DPX2NE-W8MP32W4MP-33B-00	0076	DPX3NE-240M-33S-00
0141	DPXBNE-40W1M-33P-00	0156	DPX2NE-W8MS32W4MS-33B-00	0079	DPX3NE-A240M-33SP-00
0142	DPXBNE-40W1M-33S-00	0159	DPX2NE-32W4MPW8MP-33B-00	0080	DPX3NE-A240M-33PS-00
0149	DPXBNE-32W4M-33P-00	0160	DPX2NE-32W4MSW8MS-33B-00	0091	DPX3NE-279M-33P-00
0150	DPXBNE-32W4M-33S-00			0092	DPX3NE-279M-33PS-00
M81659/31A2-001	DPXBNE-26M-33P-00	M81659/35A2-0003	DPX2N2-26MP26MP-34B-00	M81659/39A2-0005	DPX3NE-78M-34P-00
0002	DPXBNE-26M-33S-00	0004	DPX2NE-26MS26MS-34B-00	0006	DPX3NE-78M-34S-00
0009	DPXBNE-40M-33P-00	0011	DPX2NE-40MP40MP-34B-00	0013	DPX3NE-120M-34P-00
0010	DPXBNE-40M-33S-00	0012	DPX2NE-40MS40MS-34B-00	0014	DPX3NE-120M-34S-00
0017	DPXBNE-45M-33P-00	0019	DPX2NE-45MP45MP-34B-00	0021	DPX3NE-135M-34P-00
0018	DPXBNE-45M-33S-00	0020	DPX2NE-45MS45MS-34B-00	0022	DPX3NE-135M-34S-00
0025	DPXBNE-57M-33P-00	0027	DPX2NE-57MP57MP-34B-00	0029	DPX3NE-171M-34P-00
0026	DPXBNE-57M-33S-00	0028	DPX2NE-57MS57MS-34B-00	0030	DPX3NE-171M-34S-00
0033	DPXBNE-67M-33P-00	0035	DPX2NE-67MP67MP-34B-00	0037	DPX3NE-201M-34P-00
0034	DPXBNE-67M-33S-00	0036	DPX2NE-67MS67MS-34B-00	0038	DPX3NE-201M-34S-00
0041	DPXBNE-A106-33P-00	0043	DPX2NE-A106PA106P-34B-00	0045	DPX3NE-A318-34P-00
0042	DPXBNE-A106-33S-00	0044	DPX2NE-A106SA106S-34B-00	0046	DPX3NE-A318-34S-00
0083	DPXBNE-D8M-33P-00	0057	DPX2NE-A106S26MP-34B-00	0065	DPX3NE-24M-34P-00
0084	DPXBNE-D8M-33S-00	0058	DPX2NE-A106P26MS-34B-00	0066	DPX3NE-24M-34S-00
0135	DPXBNE-W8M-33P-00	0059	DPX2NE-26MPA106S-34B-00	0067	DPX3NE-122M-34SP-00
0136	DPXBNE-W8M-33S-00	0060	DPX2NE-W8MSA106P-34B-00	0068	DPX3NE-122M-34PS-00
0137	DPXBNE-10W3M-33P-00	0071	DPX2NE-67MPA106S-34B-00	0073	DPX3NE-142M-34P-00
0138	DPXBNE-10W3M-33S-00	0072	DPX2NE-67MSA106P-34B-00	0074	DPX3NE-142M-34S-00
0139	DPXBNE-32W2M-33P-00	0087	DPX2NE-A106SW8MP-34B-00	0075	DPX3NE-240M-34P-00
0140	DPXBNE-32W2M-33S-00	0088	DPX2NE-A106PW8MS-34B-00	0076	DPX3NE-240M-34S-00
0141	DPXBNE-40W1M-33P-00	0089	DPX2NE-A106S67MP-34B-00	0079	DPX3NE-A240M-34SP-00
0142	DPXBNE-40W1M-33S-00	0090	DPX2NE-A106P67MS-34B-00	0080	DPX3NE-A240M-34PS-00
0149	DPXBNE-32W4M-33P-00	0109	DPX2NE-C2P40W1MP-34B-00	0091	DPX3NE-279M-34SP-00
0150	DPXBNE-32W4M-33S-00	0110	DPX2NE-C2S40W1MS-34B-00	0092	DPX3NE-244M-34PS-00
M81659/33A2-0003	DPX2NE-26MP26MP-33B-00	0111	DPX2NE-C2P57MP-34B-00	0157	DPX3NE-244M-34SP-00
0004	DPX2NE-26MS26MS-33B-00	0112	DPX2NE-C2S57MS-34B-00	0158	DPX3NE-244M-34PS-00
0011	DPX2NE-40MP40MP-33B-00	0113	DPX2NE-AC3P67MP-34B-00		
0012	DPX2NE-40MS40MS-33B-00	0114	DPX2NE-AC3S67MS-34B-00	M81659/41A2-0007	DPX4NE-104M-33P-00
0019	DPX2NE-45MP45MP-33B-00	0115	DPX2NE-AC3PA106S-34B-00	0008	DPX4NE-104M-33S-00
0020	DPX2NE-45MS45MS-33B-00	0116	DPX2NE-AC3SA106P-34B-00	0015	DPX4NE-160M-33P-00
0027	DPX2NE-57MP57MP-33B-00	0117	DPX2NE-W8MPA106S-34B-00	0016	DPX4NE-160M-33S-00
0028	DPX2NE-57MS57MS-33B-00	0118	DPX2NE-W8MSA106P-34B-00	0023	DPX4NE-180M-33P-00
0035	DPX2NE-67MP67MP-33B-00	0119	DPX2NE-10W3P32W2MP-34B-00	0024	DPX4NE-180M-33S-00
0036	DPX2NE-67MS67MS-33B-00	0120	DPX2NE-10W3S32W2MS-34B-00	0031	DPX4NE-228M-33P-00
0043	DPX2NE-A106PA106P-33B-00	0121	DPX2NE-32W2MP40W1MP-34B-00	0032	DPX4NE-228M-33S-00
0044	DPX2NE-A106SA106S-33B-00	0122	DPX2NE-32W2MS40W1MS-34B-00	0039	DPX4NE-268M-33P-00
0057	DPX2NE-A106S26MP-33B-00	0123	DPX2NE-32W2MP45MP-34B-00	0040	DPX4NE-268M-33S-00
0058	DPX2NE-A106P26MS-33B-00	0124	DPX2NE-32W3MS45MS-34B-00	0047	DPX4NE-A424-33P-00
0059	DPX2NE-26MPA106S-33B-00	0125	DPX2NE-32W2MP57MP-34B-00	0048	DPX4NE-A424-33S-00
0060	DPX2NE-26MSA106P-33B-00	0126	DPX2NE-32W3MS57MS-34B-00	0061	DPX4NE-104M-33P-00
0071	DPX2NE-67MPA106S-33B-00	0127	DPX2NE-32W2MP67MP-34B-00	0062	DPX4NE-104M-33S-00
0072	DPX2NE-67MSA106P-33B-00	0128	DPX2NE-32W2MS67MS-34B-00	0063	DPX4NE-95M-33P-00
0087	DPX2NE-A106PW8MP-33B-00	0129	DPX2NE-32W2MPA106S-34B-00	0064	DPX4NE-95M-33S-00
0088	DPX2NE-A106PW8MS-33B-00	0130	DPX2NE-32W2MSA106P-34B-00	0085	DPX4NE-150M-33P-00
0089	DPX2NE-A106S67MP-33B-00	0131	DPX2NE-40W1MP40W1MP-34B-00	0086	DPX4NE-150M-33S-00
0090	DPX2NE-A106P67MS-33B-00	0132	DPX2NE-40W1MS40W1MS-34B-00	0095	DPX4NE-326M-33SP-00
0109	DPX2NE-C2P40W1MP-33B-00	0133	DPX2NE-57MPA106S-34B-00	0096	DPX4NE-326M-33PS-00
0110	DPX2NE-C2S40W1MS-33B-00	0134	DPX2NE-57MSA106P-34B-00	0097	DPX4NE-287M-33SP-00
0111	DPX2NE-C2P57MP-33B-00	0145	DPX2NE-W8MP57MP-34B-00	0098	DPX4NE-287M-33PS-00
0112	DPX2NE-C2S57MS-33B-00	0146	DPX2NE-W8MS57MS-34B-00	0099	DPX4NE-189M-33SP-00
0113	DPX2NE-AC3P67MP-33B-00	0147	DPX2NE-57MP26MP-34B-00	0100	DPX4NE-189M-33PS-00
0114	DPX2NE-AC3S67MS-33B-00	0148	DPX2NE-57MS26MS-34B-00	0101	DPX4NE-346M-33SP-00
0115	DPX2NE-AC3PA106S-33B-00	0151	DPX2NE-32W4MPA106S-34B-00	0102	DPX4NE-346M-33PS-00
0116	DPX2NE-AC3SA106P-33B-00	0152	DPX2NE-32W4MSA106P-34B-00		
0117	DPX2NE-W8MPA106S-33B-00	0155	DPX2NE-W8MP32W4MP-34B-00		
0118	DPX2NE-W8MSA106P-33B-00	0156	DPX2NE-W8MS32W4MS-34B-00		
0119	DPX2NE-10W3MP32W2MP-33B-00	0159	DPX2NE-32W4MPW8MP-34B-00		
0120	DPX2NE-10W3MS32W2MS-33B-00	0160	DPX2NE-32W4MSW8MS-34B-00		
0121	DPX2NE-32W2MP40W1MP-33B-00				

Dimensions shown in inch (mm)

Specifications and dimensions subject to change

www.ittcannon.com



Cross Reference from Military to Cannon Part Numbers (Continued)

Military Part Number	Cannon Part Number	Military Part Number	Cannon Part Number	Military Part Number	Cannon Part Number
M81659/43A2-0007	DPX4NE-104M-34P-00	M81659/62A2-0121	DPX2NE-32W2MP40W1MP-34S-29	M81659/65A2-0026	DPXBNA-57M-33S-00
0008	DPX4NE-104M-34S-00	0122	DPX2NE-32W2MP40W1MS-34B-29	0033	DPXBNA-67M-33P-00
0015	DPX4NE-160M-34P-00	0123	DPX2NE-32W2MP45MP-34B-29	0034	DPXBNA-67M-33S-00
0016	DPX4NE-160M-34S-00	0124	DPX2NE-32W2MS45MS-34B-29	0041	DPXBNA-A106-33P-00
0023	DPX4NE-180M-34P-00	0125	DPX2NE-32W2MP57MP-34B-29	0042	DPXBNA-A106-33S-00
0024	DPX4NE-180M-34S-00	0126	DPX2NE-32W2MS57MS-34B-29	0083	DPXBNA-D8M-33P-00
0031	DPX4NE-228M-34P-00	0127	DPX2NE-32W2MP67MP-34B-29	0084	DPXBNA-D8M-33S-00
0032	DPX4NE-228M-34S-00	0128	DPX2NE-32W2MS67MS-34B-29	0135	DPXBNA-W8M-33P-00
0039	DPX4NE-268M-34P-00	0129	DPX2NE-32W2MPA106S-34B-29	0136	DPXBNA-W8M-33S-00
0040	DPX4NE-268M-34S-00	0130	DPX2NE-32W2MSA106P-34B-29	0137	DPXBNA-10W3M-33P-00
0047	DPX4NE-A424-34P-00	0131	DPX2NE-40W1MP40W1MP-34B-29	0138	DPXBNA-10W3M-33S-00
0048	DPX4NE-A424-34S-00	0132	DPX2NE-40W1MS40W1MS-34B-29	0139	DPXBNA-32W2M-33P-00
0061	DPX4NE-104M-34P-00	0133	DPX2NE-57MPA106S-34B-29	0140	DPXBNA-32W2M-33S-00
0062	DPX4NE-104M-34S-00	0134	DPX2NE-57MSA106P-34B-29	0141	DPXBNA-40W1M-33P-00
0063	DPX4NE-95M-34P-00	0145	DPX2NE-W8MP57MP-34B-29	0142	DPXBNA-40W1M-33S-00
0064	DPX4NE-95M-34S-00	0146	DPX2NE-W8MS57MS-34B-29	0149	DPXBNA-32W4M-33P-00
0085	DPX4NE-150M-34P-00	0147	DPX2NE-57MP26MP-34B-29	0150	DPXBNA-32W4M-33S-00
0086	DPX4NE-150M-34S-00	0148	DPX2NE-57MS26MS-34B-29	M81659/66A2-0001	DPXBNA-26M-34P-00
0095	DPX4NE-326M-34SP-00	0151	DPX2NE-32W4MPA106S-34B-29	0002	DPXBNA-26M-34S-00
0096	DPX4NE-326M-34PS-00	0152	DPX2NE-32W4MSA106P-34B-29	0009	DPXBNA-40M-34P-00
0097	DPX4NE-287M-34SP-00	0155	DPX2NE-W8MP32W4MP-34B-29	0010	DPXBNA-40M-34S-00
0098	DPX4NE-287M-34PS-00	0156	DPX2NE-W8MS32W4MS-34B-29	0017	DPXBNA-45M-34P-00
0099	DPX4NE-189M-34SP-00	0159	DPX2NE-32W4MPW8MP-34B-29	0018	DPXBNA-45M-34S-00
0100	DPX4NE-189M-34PS-00	0160	DPX2NE-32W4MSW8MS-34B-29	0025	DPXBNA-57M-34P-00
0101	DPX4NE-346M-34SP-00	M81659/63A2-0005	DPX3NE-78M-34P-29	0026	DPXBNA-57M-34S-00
0102	DPX4NE-346M-34PS-00	0006	DPX3NE-78M-34S-29	0033	DPXBNA-67M-34P-00
M81659/61A2-0001	DPXBNE-26M-34P-29	0013	DPX3NE-120M-34P-29	0034	DPXBNA-67M-34S-00
0002	DPXBNE-26M-34S-29	0014	DPX3NE-120M-34S-29	0041	DPXBNA-A106-34P-00
0009	DPXBNE-40M-34P-29	0021	DPX3NE-135M-34P-29	0042	DPXBNA-A106-34S-00
0010	DPXBNE-40M-34S-29	0022	DPX3NE-135M-34S-29	0083	DPXBNA-D8M-34P-00
0017	DPXBNE-45M-34P-29	0029	DPX3NE-171M-34P-29	0084	DPXBNA-D8M-34S-00
0018	DPXBNE-45M-34S-29	0030	DPX3NE-171M-34S-29	0135	DPXBNA-W8M-34P-00
0025	DPXBNE-57M-34P-29	0037	DPX3NE-201M-34P-29	0136	DPXBNA-W8M-34S-00
0026	DPXBNE-57M-34S-29	0038	DPX3NE-201M-34S-29	0137	DPXBNA-10W3M-34P-00
0033	DPXBNE-67M-34P-29	0041	DPX3NE-A318-30-29	0138	DPXBNA-10W3M-34S-00
0034	DPXBNE-67M-34S-29	0046	DPX3NE-A318-34S-29	0139	DPXBNA-32W2M-34P-00
0041	DPXBNE-A106-34P-29	0065	DPX3NE-24M-34P-29	0140	DPXBNA-32W2M-34S-00
0042	DPXBNE-A106-34S-29	0066	DPX3NE-24M-34S-29	0141	DPXBNA-40W1M-34P-00
0083	DPXBNE-D8M-34P-29	0067	DPX3NE-122M-34SP-29	0142	DPXBNA-40W1M-34S-00
0084	DPXBNE-D8M-34S-29	0068	DPX3NE-122M-34PS-29	0149	DPXBNA-32W4M-34P-00
0135	DPXBNE-W8M-34P-29	0073	DPX3NE-142M-34P-29	0150	DPXBNA-32W4M-34S-00
0136	DPXBNE-W8M-34S-29	0074	DPX3NE-142M-34S-29	M81659 67A2-0001	DPXBNA-26M-34P-01
0137	DPXBNE-10W3M-34P-29	0075	DPX3NE-240M-34P-29	0002	DPXBNA-26M-34S-01
0138	DPXBNE-10W3M-34S-29	0076	DPX3NE-240M-34S-29	0009	DPXBNA-40M-34P-01
0139	DPXBNE-32W2M-34P-29	0079	DPX3NE-A240M-34SP-29	0010	DPXBNA-40M-34S-01
0140	DPXBNE-32W2M-34S-29	0080	DPX3NE-A240M-34PS-29	0017	DPXBNA-45M-34P-01
0141	DPXBNE-40W1M-34P-29	0091	DPX3NE-279M-34SP-29	0018	DPXBNA-45M-34S-01
0142	DPXBNE-40W1M-34S-29	0092	DPX3NE-279M-34PS-29	0025	DPXBNA-57M-34P-01
0149	DPXBNE-32W4M-34P-29	0157	DPX3NE-244M-34SP-29	0026	DPXBNA-57M-34S-01
0150	DPXBNE-32W4M-34S-29	0158	DPX3NE-244M-34PS-29	0033	DPXBNA-67M-34P-01
M81659/62A2-0003	DPX2NE-26MP-26MP-34B-29	M81659/ 64A2-0007	DPX4NE-104M-34P-29	0034	DPXBNA-67M-34S-01
0004	DPX2NE-26MS26MS-34B-29	0008	DPX4NE-104M-34S-29	0041	DPXBNA-A106-34P-01
0011	DPX2NE-40MP40MP-34B-29	0015	DPX4NE-160M-34P-29	0042	DPXBNA-A106-34S-01
0012	DPX2NE-40MS40MS-34B-29	0016	DPX4NE-160M-34S-29	0083	DPXBNA-D8M-34P-01
0019	DPX2NE-45MP45MP-34B-29	0023	DPX4NE-180M-34P-29	0084	DPXBNA-D8M-34S-01
0020	DPX2NE-45MS45MS-34B-29	0024	DPX4NE-180M-34S-29	0135	DPXBNA-W8M-34P-01
0027	DPX2NE-57MP57MP-34B-29	0031	DPX4NE-228M-34P-29	0136	DPXBNA-W8M-34S-01
0028	DPX2NE-57MS57MS-34B-29	0032	DPX4NE-228M-34S-29	0137	DPXBNA-10W3M-34P-01
0035	DPX2NE-67MP67MP-34B-29	0039	DPX4NE-268M-34P-29	0138	DPXBNA-10W3M-34S-01
0036	DPX2NE-67MS67MS-34B-29	0040	DPX4NE-268M-34S-29	0139	DPXBNA-32W2M-34P-01
0043	DPX2NE-A106PA106P-34B-29	0047	DPX4NE-A424-34P-29	0140	DPXBNA-32W2M-34S-01
0044	DPX2NE-A106SA106S-34B-29	0048	DPX4NE-A424-34S-29	0141	DPXBNA-40W1M-34P-01
0057	DPX2NE-A106S26MP-34B-29	0061	DPX4NE-104M-34P-29	0142	DPXBNA-40W1M-34S-01
0058	DPX2NE-A106P26MS-34B-29	0062	DPX4NE-104M-34S-29	0149	DPXBNA-32W4M-34P-01
0059	DPX2NE-26MPA106S-34B-29	0063	DPX4NE-95M-34P-29	0150	DPXBNA-32W4M-34S-01
0060	DPX2NE-26MSA106P-34B-29	0064	DPX4NE-95M-34S-29	M81659/68A2-0001	DPXBNA-26M-34P-23
0071	DPX2NE-67MPA106S-34B-29	0085	DPX4NE-150M-34P-29	0002	DPXBNA-26M-34S-23
0072	DPX2NE-67MSA106P-34B-29	0086	DPX4NE-150M-34S-29	0009	DPXBNA-40M-34P-23
0087	DPX2NE-A10BSW8MP-34B-29	0095	DPX4NE-326M-34SP-29	0010	DPXBNA-40M-34S-23
0088	DPX2NE-A106PW8MP-34B-29	0096	DPX4NE-326M-34PS-29	0017	DPXBNA-45M-34P-23
0089	DPX2NE-A106S67MP-34B-29	0097	DPX4NE-287M-34SP-29	0018	DPXBNA-45M-34S-23
0090	DPX2NE-A106P67MS-34B-29	0098	DPX4NE-287M-34PS-29	0025	DPXBNA-57M-34P-23
0109	DPX2NE-C2P46W1MP-34B-29	0099	DPX4NE-189M-34SP-29	0026	DPXBNA-57M-34S-23
0110	DPX2NE-C2S40W1MS-34B-29	0100	DPX4NE-189M-34PS-29	0033	DPXBNA-67M-34P-23
0111	DPX2NE-C2P57MP-34B-29	0101	DPX4NE-346M-34SP-29	0034	DPXBNA-67M-34S-23
0112	DPX2NE-C2S57MS-34B-29	0102	DPX4NE-346M-34PS-29	0041	DPXBNA-A106-34P-23
0113	DPX2NE-AC3P67MP-34B-29	M81659/65A2-0001	DPXBNA-26M-33P-00	0042	DPXBNA-A106-34S-23
0114	DPX2NE-AC3S67MS-34B-29	0002	DPXBNA-26M-33S-00	0083	DPXBNA-D8M-34P-23
0115	DPX2NE-AC3PA106S-34B-29	0009	DPXBNA-40M-33P-00	0084	DPXBNA-D8M-34S-23
0116	DPX2NE-AC3SA106P-34B-29	0010	DPXBNA-40M-33S-00	0135	DPXBNA-W8M-34P-23
0117	DPX2NE-W8MPA106S-34B-29	0017	DPXBNA-45M-33P-00	0136	DPXBNA-W8M-34S-23
0118	DPX2NE-W8MSA106P-34B-29	0018	DPXBNA-45M-33S-00	0137	DPXBNA-10W3M-34P-23
0119	DPX2NE-10W3P32W2MP-34B-29	0025	DPXBNA-57M-33P-00		
0120	DPX2NE-10W3S32W2MS-34B-29				

Dimensions shown in inch (mm)
Specifications and dimensions subject to change

www.ittcannon.com



Cross Reference from Military to Cannon Part Numbers (Continued)

Military Part Number	Cannon Part Number	Military Part Number	Cannon Part Number	Military Part Number	Cannon Part Number
M81659/68A2-0138	DPXBNA-10W3M-34S-23	M81659/70A2-0060	DPX2NA-26MSA106P-34B-00	M81659/71A2-0126	DPX2NA-32W2MS57MS-34B-01
0139	DPXBNA-32W2M-34P-23	0071	DPX2NA-67MPA106S-34B-00	0127	DPX2NA-32W2MP67MP-34B-01
0140	DPXBNA-32W2M-34S-23	0072	DPX2NA-67MSA106P-34B-00	0128	DPX2NA-32W2MS67MS-34B-01
0141	DPXBNA-40W1M-34P-23	0087	DPX2NA-A106SW8MP-34B-00	0129	DPX2NA-32W2MPA106S-34B-01
0142	DPXBNA-40W1M-34S-23	0088	DPX2NA-A106PW8MS-34B-00	0130	DPX2NA-32W2MSA106P-34B-01
0149	DPXBNA-32W4M-34P-23	0089	DPX2NA-A106S67MP-34B-00	0131	DPX2NA-40W1MP40W1MP-34B-01
0150	DPXBNA-32W4M-34S-23	0090	DPX2NA-A106P67MS-34B-00	0132	DPX2NA-40W1MS40W1MS-34B-01
M81659/69A2-0003	DPX2NA-26MP26MP-33B-00	0109	DPX2NA-C2P40W1MP-34B-00	0133	DPX2NA-57MPA106S-34B-01
0004	DPX2NA-26MS26MS-33B-00	0110	DPX2NA-C2S40W1MS-34B-00	0134	DPX2NA-57MSA106P-34B-01
0011	DPX2NA-40MP40MP-33B-00	0111	DPX2NA-C2P57MP-34B-00	0145	DPX2NA-W8MP57MP-34B-01
0012	DPX2NA-40MS40MS-33B-00	0112	DPX2NA-C2S57MS-34B-00	0146	DPX2NA-W8MS57MS-34B-01
0019	DPX2NA-45MP45MP-33B-00	0113	DPX2NA-AC3P67MP-34B-00	0147	DPX2NA-57MP26MP-34B-01
0020	DPX2NA-45MS45MS-33B-00	0114	DPX2NA-AC3S67MS-34B-00	0148	DPX2NA-57MS26MS-34B-01
0027	DPX2NA-57MP57MP-33B-00	0115	DPX2NA-AC3PA106S-34B-00	0151	DPX2NA-32W4MPA106S-34B-01
0028	DPX2NA-57MS57MS-33B-00	0116	DPX2NA-AC3SA106P-34B-00	0152	DPX2NA-32W4MSA106P-34B-01
0035	DPX2NA-67MP67MP-33B-00	0117	DPX2NA-W8MPA106S-34B-00	0155	DPX2NA-W8MP32W4MP-34B-01
0036	DPX2NA-67MS67MS-33B-00	0118	DPX2NA-W8MSA106P-34B-00	0156	DPX2NA-W8MS32W4MS-34B-01
0043	DPX2NA-A106PA106P-33B-00	0119	DPX2NA-10W3P32W2MP-34B-00	0159	DPX2NA-32W4MPW8MP-34B-01
0044	DPX2NA-A106SA106S-33B-00	0120	DPX2NA-10W3S32W2MS-34B-00	0160	DPX2NA-32W4MSW8MS-34B-01
0057	DPX2NA-A106S26MP-33B-00	0121	DPX2NA-32W2MP40W1MP-34B-00	M81659/72A2-0003	DPX2NA-26MP26MP-34B-23
0058	DPX2NA-A106P26MS-33B-00	0122	DPX2NA-32W2MS40W1MS-34B-00	0004	DPX2NA-26MS26MS-34B-23
0059	DPX2NA-26MPA106S-33B-00	0123	DPX2NA-32W2MP45MP-34B-00	0011	DPX2NA-40MP40MP-34B-23
0060	DPX2NA-26MSA106P-33B-00	0124	DPX2NA-32W2MS45MS-34B-00	0012	DPX2NA-40MS40MS-34B-23
0071	DPX2NA-67MPA106S-33B-00	0125	DPX2NA-32W2MP57MP-34B-00	0019	DPX2NA-45MP45MP-34B-23
0072	DPX2NA-67MSA106P-33B-00	0126	DPX2NA-32W2MS57MS-34B-00	0020	DPX2NA-45MS45MS-34B-23
0087	DPX2NA-A106SW8MP-33B-00	0127	DPX2NA-32W2MP67MP-34B-00	0027	DPX2NA-57MP57MP-34B-23
0088	DPX2NA-A106PW8MS-33B-00	0128	DPX2NA-32W2MS67MS-34B-00	0028	DPX2NA-57MS57MS-34B-23
0089	DPX2NA-A106S67MP-33B-00	0129	DPX2NA-32W2MPA106S-34B-00	0035	DPX2NA-67MP67MP-34B-23
0090	DPX2NA-A106P67MS-33B-00	0130	DPX2NA-32W2MSA106P-34B-00	0036	DPX2NA-67MS67MS-34B-23
0109	DPX2NA-C2P40W1MP-33B-00	0131	DPX2NA-40W1MP40W1MP-34B-00	0043	DPX2NA-A106PA106P-34B-23
0110	DPX2NA-C2S40W1MS-33B-00	0132	DPX2NA-40W1MS40W1MS-34B-00	0044	DPX2NA-A106SA106S-34B-23
0111	DPX2NA-C2P57MP-33B-00	0133	DPX2NA-57MPA106S-34B-00	0057	DPX2NA-A106S26MP-34B-23
0112	DPX2NA-C2S57MS-33B-00	0134	DPX2NA-57MSA106P-34B-00	0058	DPX2NA-A106P26MS-34B-23
0113	DPX2NA-AC3P67MP-33B-00	0145	DPX2NA-W8MP57MP-34B-00	0059	DPX2NA-A106SW8MP-34B-23
0114	DPX2NA-AC3S67MS-33B-00	0146	DPX2NA-W8MS57MS-34B-00	0060	DPX2NA-26MSA106P-34B-23
0115	DPX2NA-AC3PA106S-33B-00	0147	DPX2NA-57MP26MP-34B-00	0071	DPX2NA-67MPA106S-34B-23
0116	DPX2NA-AC3SA106P-33B-00	0148	DPX2NA-57MS26MS-34B-00	0072	DPX2NA-67MSA106P-34B-23
0117	DPX2NA-W8MPA106S-33B-00	0151	DPX2NA-32W4MPA106S-34B-00	0087	DPX2NA-A106SW8MP-34B-23
0118	DPX2NA-W8MSA106P-33B-00	0152	DPX2NA-32W4MSA106P-34B-00	0088	DPX2NA-A106PW8MS-34B-23
0119	DPX2NA-10W3P32W2MP-33B-00	0155	DPX2NA-W8MP32W4MP-34B-00	0089	DPX2NA-A106S67MP-34B-23
0120	DPX2NA-10W3S32W2MS-33B-00	0156	DPX2NA-W8MP32W4MPS-34B-00	0090	DPX2NA-A106P67MS-34B-23
0121	DPX2NA-32W2MP40W1MP-33B-00	0159	DPX2NA-32W4MPW8MP-34B-00	0109	DPX2NA-C2P40W1MP-34B-23
0122	DPX2NA-32W2MS40W1MS-33B-00	0160	DPX2NA-32W4MSW8MS-34B-00	0110	DPX2NA-C2S40W1MS-34B-23
0123	DPX2NA-32W2MP45MP-33B-00	M81659/71A2-0003	DPX2NA-26MP26MP-34B-01	0111	DPX2NA-C2P57MP-34B-23
0124	DPX2NA-32W2MS45MS-33B-00	0004	DPX2NA-26MS26MS-34B-01	0112	DPX2NA-C2S57MS-34B-23
0125	DPX2NA-32W2MP57MP-33B-00	0011	DPX2NA-40MP40MP-34B-01	0113	DPX2NA-AC3P67MP-34B-23
0126	DPX2NA-32W2MS57MS-33B-00	0012	DPX2NA-40MS40MS-34B-01	0114	DPX2NA-A106PW8MS-34B-23
0127	DPX2NA-32W2MP67MP-33B-00	0019	DPX2NA-45MP45MP-34B-01	0115	DPX2NA-AC3PA106S-34B-23
0128	DPX2NA-32W2MS67MS-33B-00	0020	DPX2NA-45MS45MS-34B-01	0116	DPX2NA-AC3SA106P-34B-23
0129	DPX2NA-32W2MPA106S-33B-00	0027	DPX2NA-57MP57MP-34B-01	0117	DPX2NA-W8MPA106S-34B-23
0130	DPX2NA-32W2MSA106P-33B-00	0028	DPX2NA-57MS57MS-34B-01	0118	DPX2NA-W8MSA106P-34B-23
0131	DPX2NA-40W1MP40W1MP-33B-00	0035	DPX2NA-67MP67MP-34B-01	0119	DPX2NA-10W3P32W2MP-34B-23
0132	DPX2NA-40W1MS40W1MS-33B-00	0036	DPX2NA-67MS67MS-34B-01	0120	DPX2NA-10W3S32W2MS-34B-23
0133	DPX2NA-57MPA106S-33B-00	0043	DPX2NA-A106PA106P-34B-01	0121	DPX2NA-32W2MP40W1MP-34B-23
0134	DPX2NA-57MSA106P-33B-00	0044	DPX2NA-A106SA106S-34B-01	0122	DPX2NA-32W2MS40W1MS-34B-23
0145	DPX2NA-W8MP57MP-33B-00	0057	DPX2NA-A106S26MP-34B-01	0123	DPX2NA-32W2MP45MP-34B-23
0146	DPX2NA-W8MS57MS-33B-00	0058	DPX2NA-A106P26MS-34B-01	0124	DPX2NA-32W2MS45MS-34B-23
0147	DPX2NA-57MP26MP-33B-00	0059	DPX2NA-26MPA106S-34B-01	0125	DPX2NA-32W2MP57MP-34B-23
0148	DPX2NA-57MS26MS-33B-00	0060	DPX2NA-26MSA106P-34B-01	0126	DPX2NA-32W2MS57MS-34B-23
0151	DPX2NA-32W4MPA106S-33B-00	0071	DPX2NA-67MPA106S-34B-01	0127	DPX2NA-32W2MP67MP-34B-23
0152	DPX2NA-32W4MPA106P-33B-00	0072	DPX2NA-67MSA106P-34B-01	0128	DPX2NA-32W2MS67MS-34B-23
0155	DPX2NA-W8MP32W4MP-33B-00	0087	DPX2NA-A106SW8MP-34B-01	0129	DPX2NA-32W2MPA106S-34B-23
0156	DPX2NA-W8MS32W4MS-33B-00	0088	DPX2NA-A106PW8MS-34B-01	0130	DPX2NA-32W2MSA106P-34B-23
0159	DPX2NA-32W4MPW8MP-33B-00	0089	DPX2NA-A106S67MP-34B-01	0131	DPX2NA-40W1MP40W1MP-34B-23
0160	DPX2NA-32W4MSW8MS-33B-00	0090	DPX2NA-A106P67MS-34B-01	0132	DPX2NA-40W1MS40W1MS-34B-23
M81659/70A2-0003	DPX2NA-26MP26MP-34B-00	0109	DPX2NA-C2P40W1MP-34B-01	0133	DPX2NA-57MPA106S-34B-23
0004	DPX2NA-26MS26MS-34B-00	0110	DPX2NA-C2S40W1MS-34B-01	0134	DPX2NA-57MSA106P-34B-23
0011	DPX2NA-40MP40MP-34B-00	0111	DPX2NA-C2P57MP-34B-01	0145	DPX2NA-W8MP57MP-34B-23
0012	DPX2NA-40MS40MS-34B-00	0112	DPX2NA-C2S57MS-34B-01	0146	DPX2NA-W8MS57MS-34B-23
0019	DPX2NA-45MP45MP-34B-00	0113	DPX2NA-AC3P67MP-34B-01	0147	DPX2NA-57MP26MP-34B-23
0020	DPX2NA-45MS45MS-34B-00	0114	DPX2NA-AC3S67MS-34B-01	0148	DPX2NA-57MS26MS-34B-23
0027	DPX2NA-57MP57MP-34B-00	0115	DPX2NA-AC3PA106S-34B-01	0151	DPX2NA-32W4MPA106S-34B-23
0028	DPX2NA-57MS57MS-34B-00	0116	DPX2NA-AC3SA106P-34B-01	0152	DPX2NA-32W4MSA106P-34B-23
0035	DPX2NA-67MP67MP-34B-00	0117	DPX2NA-W8MPA106S-34B-01	0155	DPX2NA-W8MP32W4MP-34B-23
0036	DPX2NA-67MS67MS-34B-00	0118	DPX2NA-W8MSA106P-34B-01	0156	DPX2NA-W8MS32W4MS-34B-23
0043	DPX2NA-A106PA106P-34B-00	0119	DPX2NA-10W3P32W2MP-34B-01	0159	DPX2NA-32W4MPW8MP-34B-23
0044	DPX2NA-A106SA106S-34B-00	0120	DPX2NA-10W3S32W2MS-34B-01	0160	DPX2NA-32W4MSW8MS-34B-23
0057	DPX2NA-A106S26MP-34B-00	0121	DPX2NA-32W2MP40W1MP-34B-01		
0058	DPX2NA-A106P26MS-34B-00	0122	DPX2NA-32W2MS40W1MS-34B-01		
0059	DPX2NA-26MPA106P-34B-00	0123	DPX2NA-32W2MP45MP-34B-01		
		0124	DPX2NA-32W2MS45MS-34B-01		
		0125	DPX2NA-32W2MP57MP-34B-01		

Dimensions shown in inch (mm)
 Specifications and dimensions subject to change

www.ittcannon.com



Coaxial Cable Reference Guide

For BKA*, DPX Series (Crimp, & Solder)

Reference MIL-C-17D & DPX NE/NA MIL-C-81659 Series

RG/U Type	Inner Conductor	Dielectric Material	DOD (Inch)	Jacket Material	O.D (Inch)	Weight (lbs/ft)	Max. Oper. Temp. Range (C)	Max. Oper. Voltage (Volts RMS)	Suggested Alt Cable	Code Crimp Type Coax	Code Solder Type Coax	DPX NE/NA Military
7	0.0359"	Air-space PE	0.250	PVC	0.370	0.080	- 40 + 80	1,000	Use RG63B	-	I	-
9	0.0855"	PE	0.280	PVC	0.420	0.140	- 40 + 80	4,000	Use RG214	-	R,AC	-
55	0.0320"	PE	0.116	PE	0.206 MAX	0.032	- 55 + 80	1,900	Use RG55B	S	C,J	-
58	0.0320" BC	PE	0.116	PVC	0.195	0.029	- 40 + 80	1,900	Use RG58B	D,P,G J,AC,AD	C,J,Z, AB	Size 5/9 Seal 1
59	0.0253"	PE	0.146	PVC	0.242	0.032	- 40 + 80	2,300	Use RG59B	A,F,T	D	-
59B	0.0230'	PE	0.146	PVC	0.242	0.032	- 40 + 80	2,300	Use up to 1000 MHz	-	-	-
62	0.0253"	Air-space PE	0.146	PVC	0.242	0.038	- 40 + 80	750	Use RG62A	A,F,T	E	-
62A	0.0253"	Air-space PE	0.146	PVC	0.242	0.038	- 40 + 80	750	-	-	-	-
71	0.0253"	Air-space PE	0.146	PVC	0.250 Max.	0.046	- 40 + 80	750	Use RG71B	-	E	-
115	0.0840"	PTFE	0.250	FG Braid	0.375	0.148	- 55 + 250	5,000	Use RG115A	V	-	-
142	0.0359"	PTFE	0.116	FG Braid	0.206 Max	0.047	- 55 + 250	1,900	Use RG142A	S,AE	-	Size 5/9 Seal 1
142B	0.0390"	PTFE	0.116	FEP	0.195	0.050	- 55 + 200	1,900	-	-	-	-
174	0.0189"	PE	0.060	PVC	0.100	0.008	- 40 + 80	1,500	-	D,H,U AF	-	Size 5/9 Seal 2
178	0.0120"	PTFE	0.036	KEL-F	0.079 Max	0.0054	- 40 + 150	1,000	Use RG178B	E,R,K,AG, L,M,AF	-	Size 5/9 Seal 1
179	0.0120"	PTFE	0.057	KEL-F	0.094 Max	0.010	- 55 + 150	1,200	Use RG179B	D,H,U AF	-	Size 5/9 Seal 1 Seal 2
179B	0.0120"	PTFE	0.063	FEP	0.100	0.010	- 55 + 200	1,200	-	-	-	-
180	0.0120"	PTFE	0.103	KEL-F	0.141 Max.	0.019	- 40 + 150	1,500	Use RG180B	C,AB	B	Size 5/9 Seal 1
180B	0.0120"	PTFE	0.102	FEP	0.145 Max	0.019	- 55 + 200	1,500	-	AB	-	-
187	0.0120"	PTFE	0.060	PTFE	0.110 Max.	0.010	- 55 + 250	1,200	Use RG179B	D,H,U AF	A,K	-
188	0.0201"	PTFE	0.060	PTFE	0.110 Max.	0.011	- 55 + 250	1,200	Use RG316	D,H,U, AF	A,K	-
195		PTFE	0.102	PTFE	0.155 Max.	0.020	- 55 + 250	1,500	Use RG180B	C,AB	B	-
196		PTFE	0.034	PTFE	0.080 Max.	0.006	- 55 + 250	1,000	Use RG178B	E,R,K, L,AA,AG	AA	Size 5/9 Seal 1
214	0.0888"	PE	0.285	PVC	0.425	0.126	- 40 + 80	5,000	-	-	R,AC	-
223	0.035"	pE	0.116	PVC	0.216 Max.	0.034	- 40 + 80	1,900	-	-	C,J	-
225	0.0936'	PTFE	0.285	FG Braid	0.430	0.180	- 55 + 250	5,000	-	-	-	Size 5/9 Seal 2
316	0.0201"	PTFE	0.060	FEP	0.102	0.012	- 55 + 200	1,200	Use RG188A	-	-	Size 5/9 Seal 2
393	0.0936"	PTFE	0.285	FEP	0.390	0.165	- 55 + 200	5,000	Use RG225	-	-	-
400	0.0385"	PTFE	0.116	FEP	0.195	0.050	- 55 + 200	1,900	-	-	-	-
402	0.0360'	PTFE	0.119	None	0.141	0.032	- 55 + 200	2,500	Use RG142B	-	-	-

Junction Shells

90° Angle

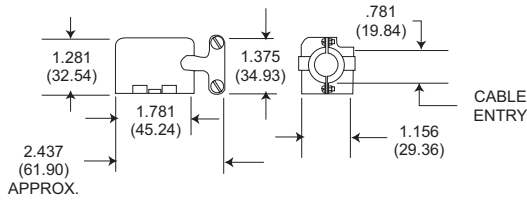

Style	Part Number
(Right) DPXA	20745-22
(Left) DPXA	20745-23
(Right) DPX2	20745-10
(Left) DPX2	20745-11

(DPXA ONLY)
DIECAST STRAIGHT JUNCTION SHELL

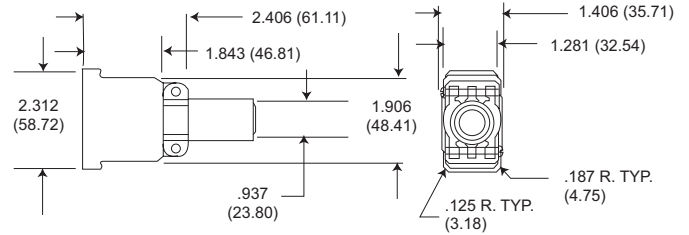

Style	Part Number
DPXA	22017

90° Angle DPX2
Junction Shell (Side Outlet)

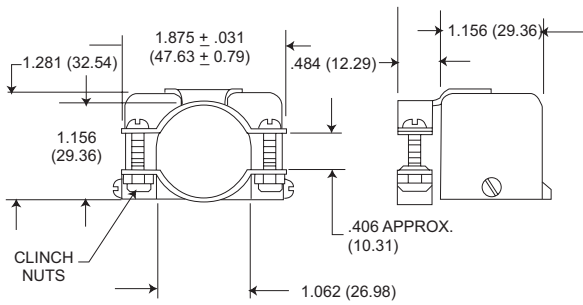

Style	Part Number
DPX2	20745-12

(DPXA ONLY)
DIECAST STRAIGHT JUNCTION SHELL (LONG)

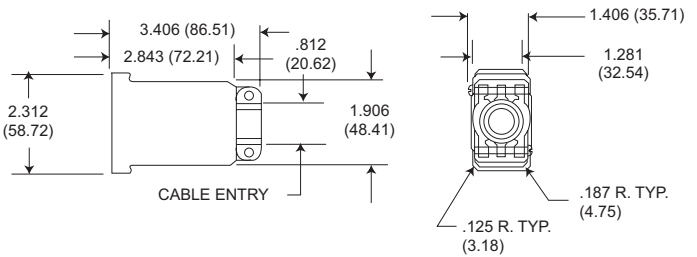

Style	Part Number
DPXA	22017-2

(DPXA ONLY)
DIECAST 90° ANGLE JUNCTION SHELL

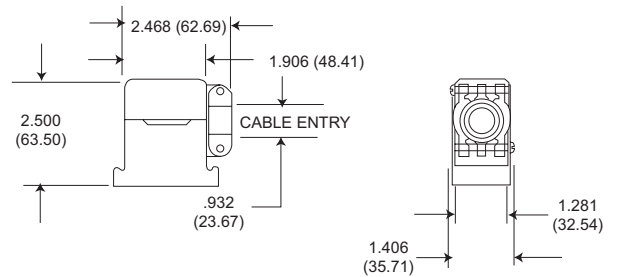

Style	Part Number
DPXA	22017-1

Diecast junction shells may be used on DPXA connectors. They have 4-40 NC-2B tapped mounting holes for attaching to the shell mounting hardware.

STRAIGHT JUNCTION SHELL

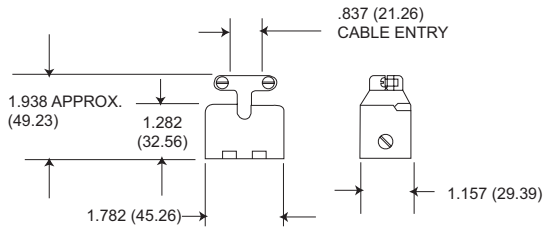

Style	Part Number
DPXA	20745-21
DPX2	20745-8

* DPX2 Junction Shells are also used on DPXB connectors.

Dust Caps



Conductive
DPXB-60-1 for 34 Shell
Conductive Dust Caps
025-0767-001
Protect Against
Static Electricity



Conductive
DPXA-59 for 33 Shell
025-0749-001

Dimensions shown in inch (mm)
Specifications and dimensions subject to change

www.ittcannon.com



Sealing Plugs

P/N 225-0090-000 only
Material: Teflon

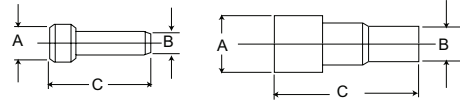

* Applies to 225-0090-000

Part Number	Contact Size	Color	A	B	C
225-1013-000	22	Black	.063 (1.6)	.040 (1.0)	.469 (11.9)
225-0070-000	20	Red	.085 (2.2)	.065 (1.6)	.469 (11.9)
225-0071-000	16	Blue	.115 (2.9)	.075 (1.9)	.469 (11.9)
225-0072-000	12	Yellow	.171 (4.3)	.121 (3.1)	.564 (14.3)
225-0090-000	#5 and #9 Coax	White	.365 (9.3)	.287 (7.3)	.835 (21.2)

Filler Plugs

P/N 225-0099-000 only
Material: Thermoplastic

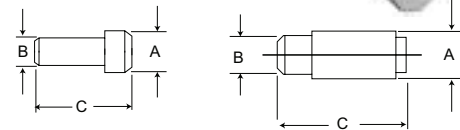

* Applies to 225-0099-000

Part Number	Contact Size	Color	A	B	C
225-0094-000	22	Black	.069 (1.7)	.051 (1.3)	.420 (10.7)
225-0095-000	20	Red	.083 (2.1)	.069 (1.7)	.350 (8.9)
225-0096-000	16	Blue	.131 (3.3)	.108 (2.7)	.320 (8.1)
225-0097-000	12	Yellow	.187 (4.7)	.156 (4.0)	.320 (8.1)
225-0098-000	#5 Coax (Pin)	White	.275 (7.0)	.251 (6.4)	.450 (11.4)
225-0099-000	#5 and #9 Coax (Socket)	White	.275 (7.0)	.251 (6.4)	1.061 (26.9)

(See Customer Use Drawing for details)



DPXA - Single Shell DPX

DPXA connectors are one-piece shell miniature rack/panel connectors. The construction offers high strength and maximum utilization of insert area for contact arrangements accommodating up to 106 contacts. Shells are keystone-shaped for polarization. Operating temperature for the DPXA is -54.2°C to +125°C (-67°F to +257°F).



DPXA-34



DPXB-33

DPXB - Polarized ARINC Shell

DPXB connectors are DPXA connectors with an ARINC B shelf. Additional polarization is provided by three hexagonal polarizing posts.

DPX2 - Two Gang DPX Series

DPX2 connectors are the original two-gang versions of the DPX, and are made of the same materials and accommodate the same contact arrangements. Keystone shaped shells accommodate two DPX inserts with up to 212 contacts. The DPX2 has three polarizing posts with 99 polarizing positions.



DPX2-34B



DPX2-33B

DPX2 - A - ARINC A Shell

DPX2-A connectors are DPX2 connectors with an ARINC A shell. This shell type has the receptacle flange placed .344 (8.74) from the front of the engaging portion of the shell, and short aluminum alloy polarizing posts permit polarization before contacts engage.

DPX2-B - ARINC B Shell

DPX2-B connectors supersede the DPX2-A and have an ARINC B Shell. This Shell type has the

receptacle flange placed .060 (1.52) from the front of the engaging portion of the shell, and polarizing posts permit polarization before the shells engage.

DPX3 - Three Gang DPX Series

DPX3 connectors are three-gang versions of the DPX, made of the same materials, and accommodate the same contact arrangements. The three-gang version can therefore accommodate up to a total of 318 in the keystone shaped shells, with three polarizing posts that are capable of providing up to 99 polarizing positions.



DPX3-34



DPX4-33

DPX4 - Four Gang DPX Series

DPX4 connectors are four gang versions of the DPX, made of the same materials, and can accommodate four separate arrangements that can total up to 424 contacts. The DPX4 has three polarizing posts with 99 polarizing positions.

DPX*MA - LITTLE CAESAR® Contact Assembly

DPX*MA connectors are DPX connectors with the LITTLE CAESAR contact assembly for rear insertion, release, and extraction of crimp type contacts. Insertion requires no tool; extraction requires an expendable plastic tool. A hard dielectric, closed-entry socket insert has lead-in chamfers for positive mating of contacts. Contacts are crimpable with the M22501 tool.

DPX*ME - Environmental with LITTLE CAESAR® Contact Assembly

DPX*ME connectors are DPXMA connectors with environmental interfacial and grommet seals, and olive drab shell finish.

Performance and Material Specifications (DPXA/DPXB/DPX*MA/DPX*ME)

		DPXA/DPXB/DPX2	DPX*MA/DPX2*MA/ME	Specifications
Shell	Material	Aluminum alloy	Aluminum alloy	QQ- A-591/A380
	Finish	Cadmium plate with yellow chromate	Cadmium plate with yellow chromate for MA; olive drab for ME	QQ-P-416
Insulator	Material	Melamine or Phenolic	Diallyl phthalate or epoxy	MIL-M-14
	Termination	Solder Pot	Crimp	N/A
Contacts	Material	Copper alloy	Copper alloy	QQ-C-533
	Finish	Gold	Gold	MIL-G-45204
Polarizing Posts	Material	Die Cast	Die cast	
	Finish	Cadmium	Cadmium	QQ-P-416
Screws & Lockwashers	Material	Steel	Steel	QQS-630-637
	Finish	Cadmium Plate	Cadmium plate	QQ-P-416
Seals	Material	N/A	Silicone	N/A

How to Order

DPXA/DPXB

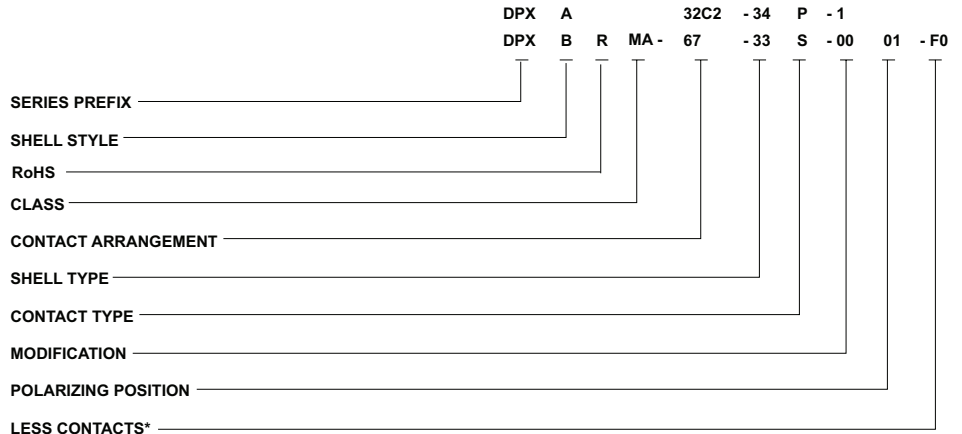

SERIES PREFIX
DPX - ITT designation

SHELL STYLE
A - Single shell
B - Polarized ARINC shell

RoHS version
R - RoHS compatible

CLASS
No designator - Solder type
MA - Crimp type with LITTLE CAESAR contact assembly
ME - Environmental crimp type
MB - Wire separator
MK - Mounting springs

CONTACT ARRANGEMENT
2 thru 106 (see pages 52-56)

SHELL TYPE
33 for plug; 34 for receptacle

CONTACT TYPE
P for pin; S for socket

MODIFICATION
DPXA - See page 68-71
DPXB - See pages 68-71

POLARIZING POSITION
For DPXB shell style only

DPX2

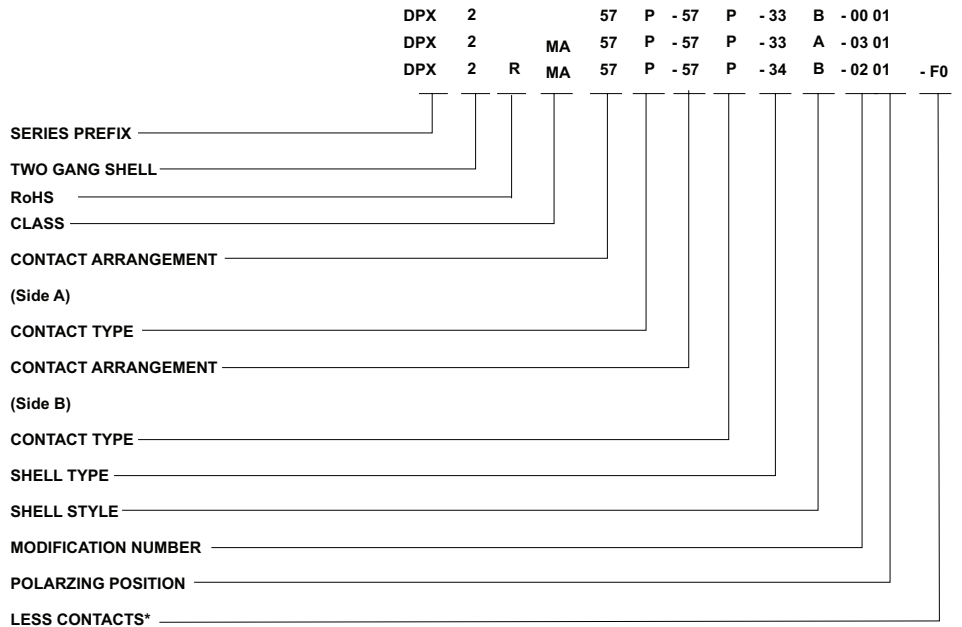

SERIES PREFIX
DPX - ITT Cannon designation

SHELL
2 - Two gang

RoHS
R - RoHS compatible

CLASS
No designator - Solder type
MA - Crimp type with LITTLE CAESAR contact

CONTACT ARRANGEMENT
2 thru 106 (see pages 52-56)

CONTACT TYPE
P for pin; S for socket

SHELL TYPE
33 for plug; 34 for receptacle

SHELL STYLE
No designator - original two-gang DPX
A - ARINC A shell
B - ARINC B shell

MODIFICATION
See pages 68-71

POLARIZING POSITION
See pages 71-72



How to Order

DPX3/DPX4

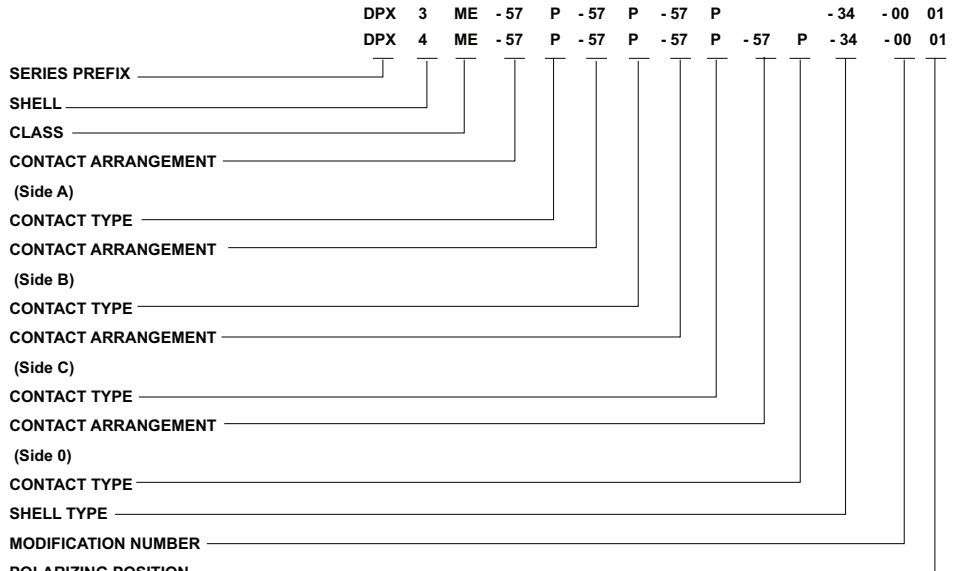

SERIES PREFIX

DPX - ITT designation

SHELL

3 - Three gang 4 - Four gang

CLASS

MA - Crimp type contacts in LITTLE CAESAR contact assembly
 ME - Environment- resistant, crimp type contacts

***CONTACT ARRANGEMENT**

See pages 52-56 for applicable arrangements. Please specify each arrangement number as indicated in ordering nomenclature for 3 or 4 gang if not listed below.

SHELL TYPE
 33 for plug; 34 for receptacle

MODIFICATION See pages 68-71

POLARIZING POSITION See pages 71-72

P for pin; S for socket. Designation follows each arrangement as ordered for 3 or 4 gang versions.

DPXMA/ME

DPXMA/DPXME - 0PX - 3 Shell Layouts

Layout	Insert - Used in shell position as noted					
	MA:	W8	32W4	57	67	A106
	ME:	AW8	A32W4	57	67	A106
*E24		A,B,C				
*F122		A,B				C
G122		B		A,C		
*E142		C			A,B	
*A166			C		A,B	
171				A,B,C		
201					A,B,C	
*C205			C		A	B
B240					A,C	B
C240					A,B	C
*D244			C			A,B
A279					C	A,B
A318						A,B,C

*Applicable to "ME" only. Consult factory for similar layouts application to "MA."

NOTE: For pictorial views of above layouts see pages 52-56.

DPXMA/DPXME - 0PX - 4 Shell Layouts

Layout	Insert - Used in shell position as noted							
	MA:	W8	26	32W4	57	67	A106	None
	ME:	AW8	26	A32W4	57	67	A106	None
145			A,B,C			D		
*B148		C,D	B				A	
B150		A,B		A,C	C,D			
*181		B			A	C	D	
*B189		C,D			B	A		
*A198				C,D	A,B,C	A,B		
268						A,B,C,D		
*E287		D				B	A,C	
*220		B					C,D	A
*A233				A		B,C,D		
279						A	C,D	B
*F287		B				A	C,D	
*E326		B					A,C,D	
A346						C,D	A,B	
B346						A,B	C,D	
385						A	B,C,D	
A424								

Dimensions shown in inch (mm)
 Specifications and dimensions subject to change

www.ittcannon.com



Single Gang

DPXA-33

All tolerances $\pm .015(0.38)$ unless otherwise noted.

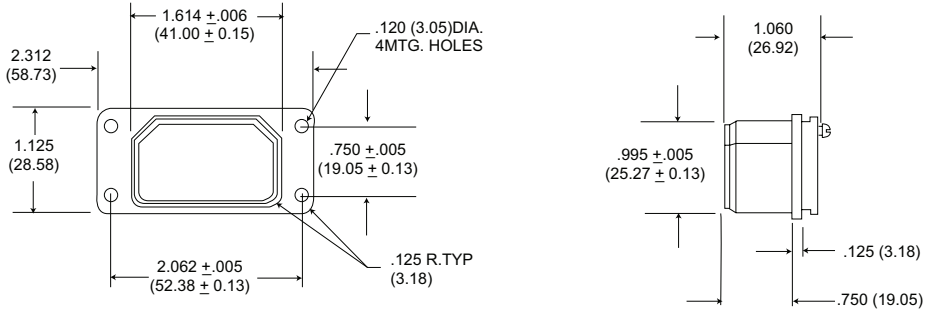

DPXA-34

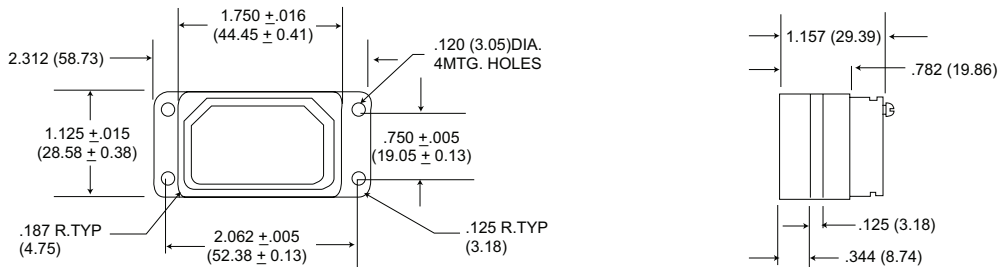

DPXA-33 ARINC Shell

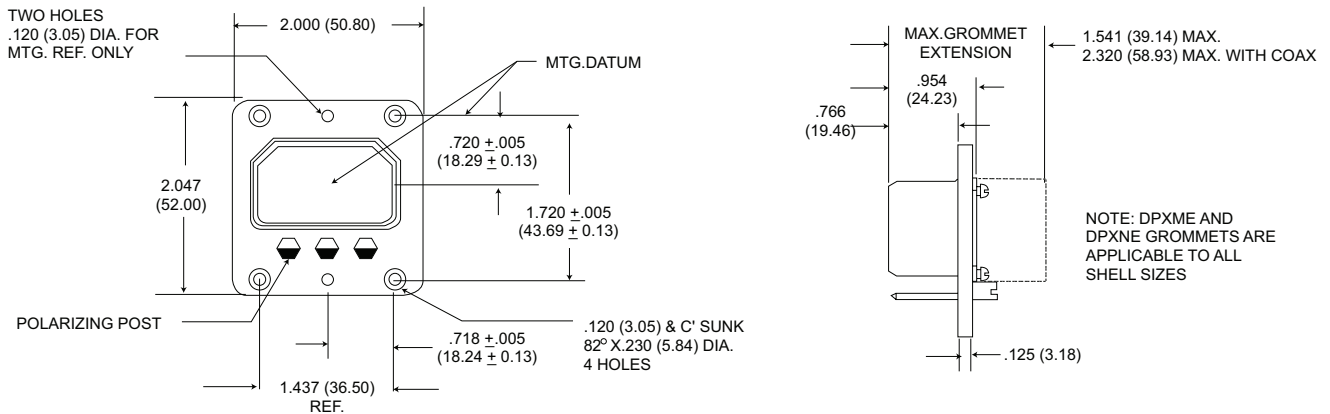

DPXA-34 ARINC Shell

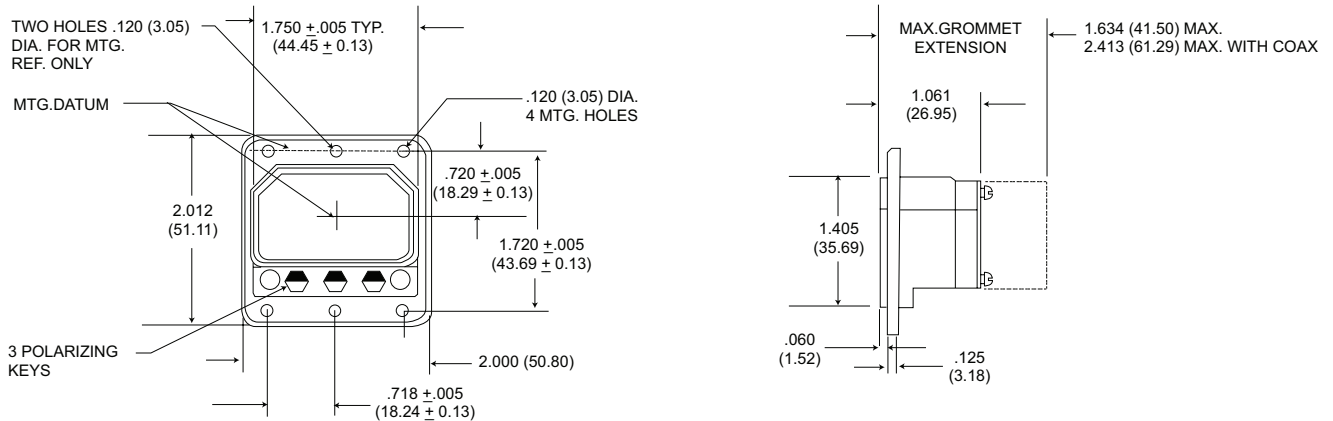

NOTE - ARINC requires that DPXB shells are mounted with the polarizing posts at the top. See pages 71-72

Dimensions shown in inch (mm)
Specifications and dimensions subject to change

www.ittcannon.com



Two Gang

DPX2-33 Shell

All tolerance are $\pm .015$ (0.38) unless otherwise noted.

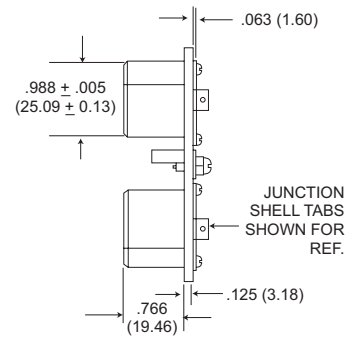
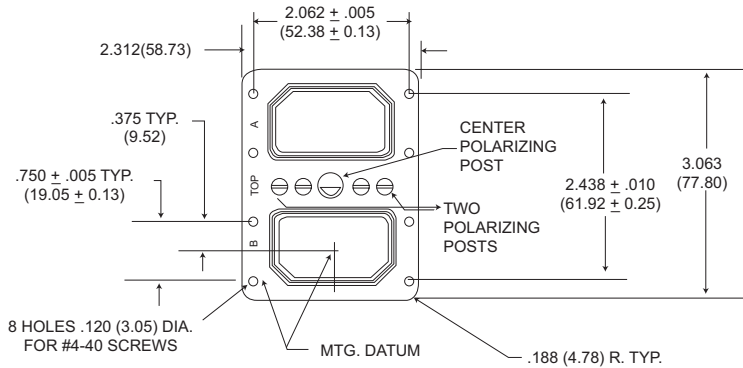

DPX2-34 Shell

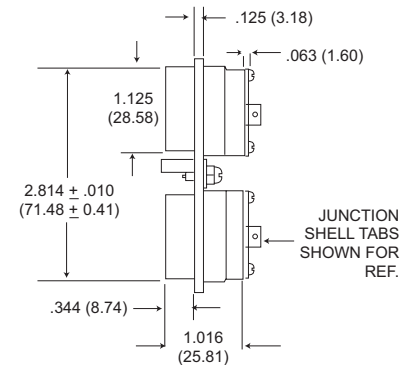
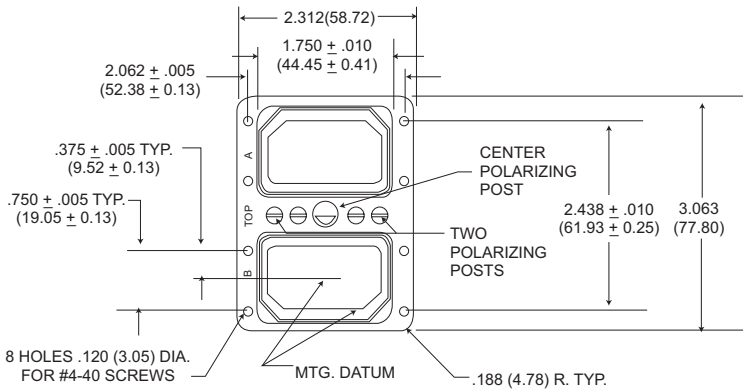

DPX2-33A ARINC A Shell

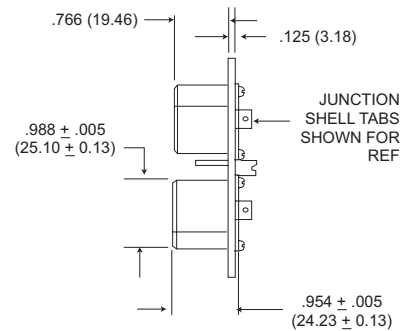
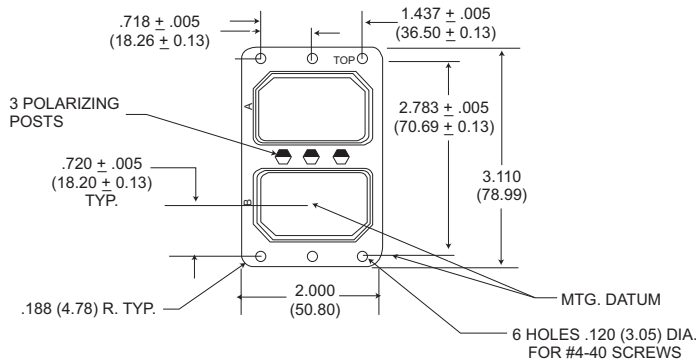

DPX2-34A ARINC A Shell

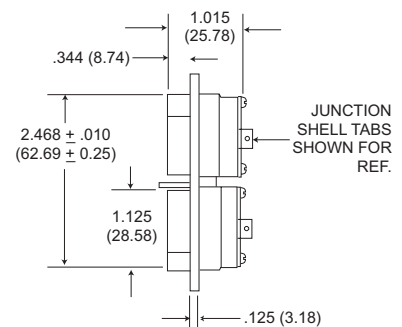
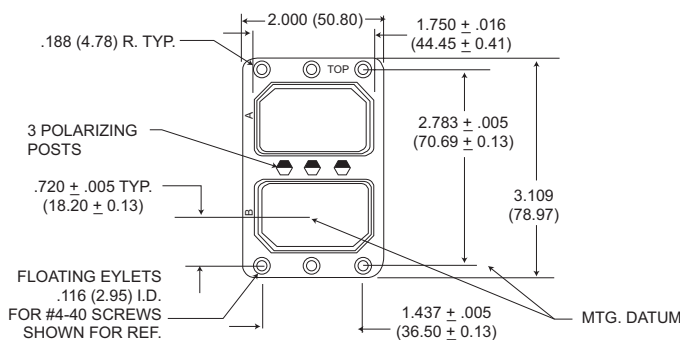

Two Gang - ARINC B Shell

DPX2-33B

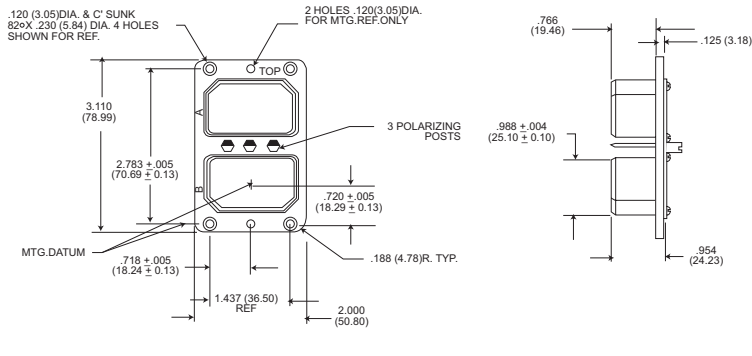

DPX2-34B

All tolerances are ± .015(0.38) unless otherwise noted.

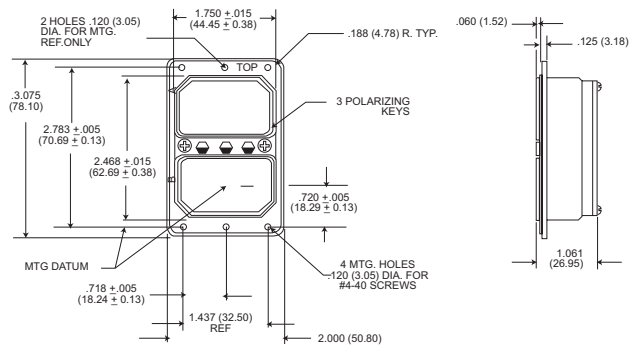

Two Gang - Screw Coupling

DPX2-33F (Female)

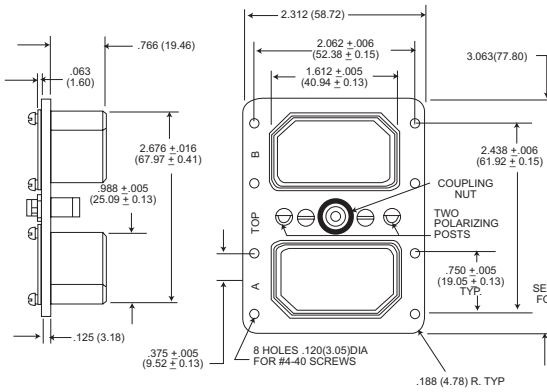

DPX2-34M (Male)

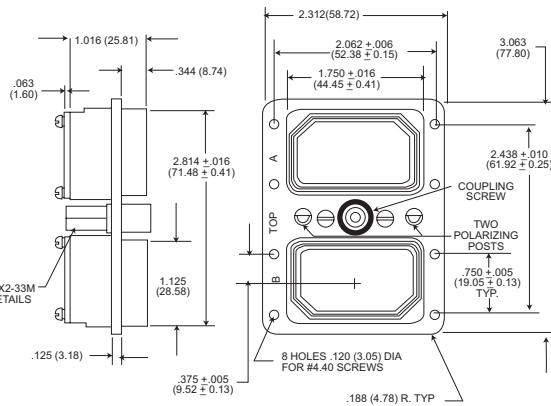

DPX2-34F (Female)

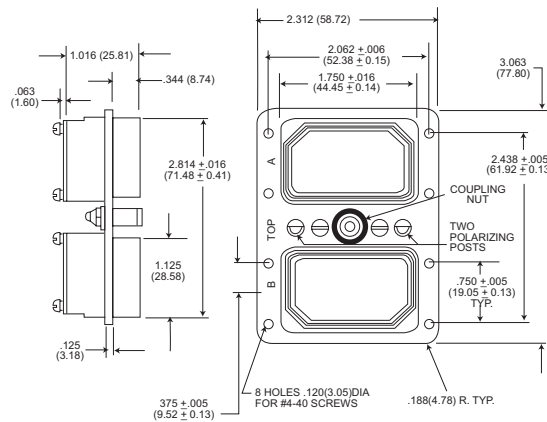

DPX2-33M (Male)

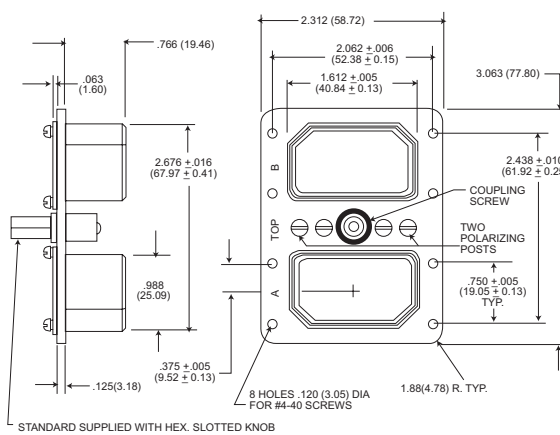

Engaging Devices

DPX2-34M with wing handle type -0901; example, DPX2-34M-0901

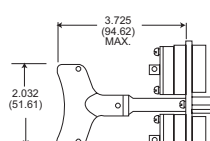

DPX2-34M with extended hex, knob type -0501; example, DPX2-34M-0501

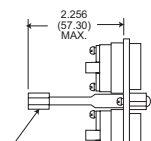

Dimensions shown in inch (mm)
Specifications and dimensions subject to change

www.ittcannon.com

Two Gang - ARINC B Shell

DPX3-33

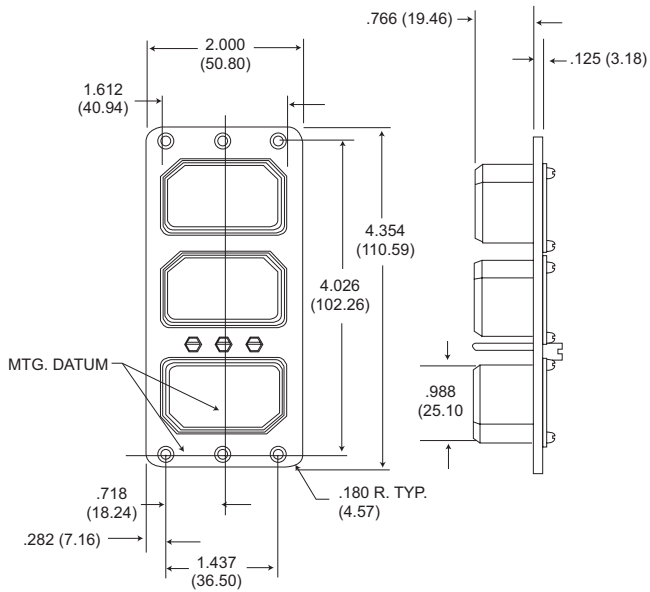

DPX3-34

All tolerances are $\pm .015(0.38)$ unless otherwise noted.

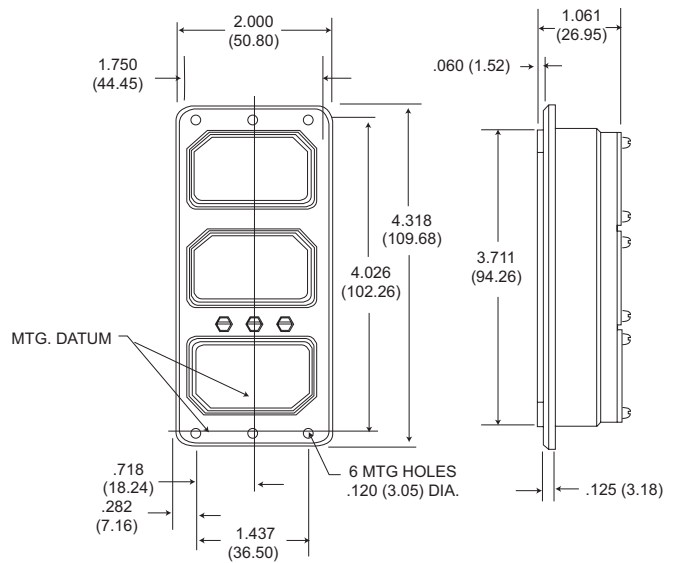

Four Gang

DPX4-33

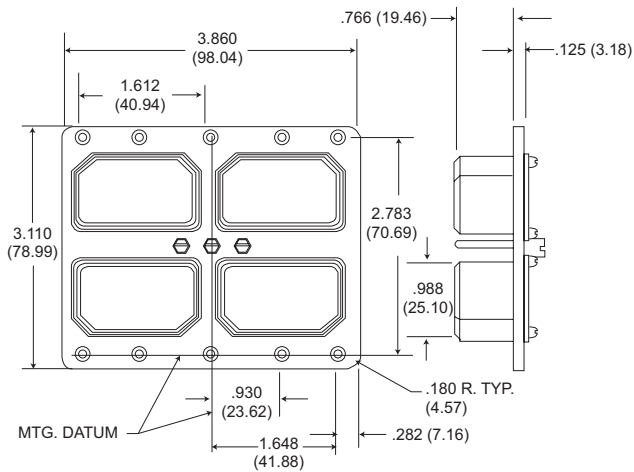

DPX4-34

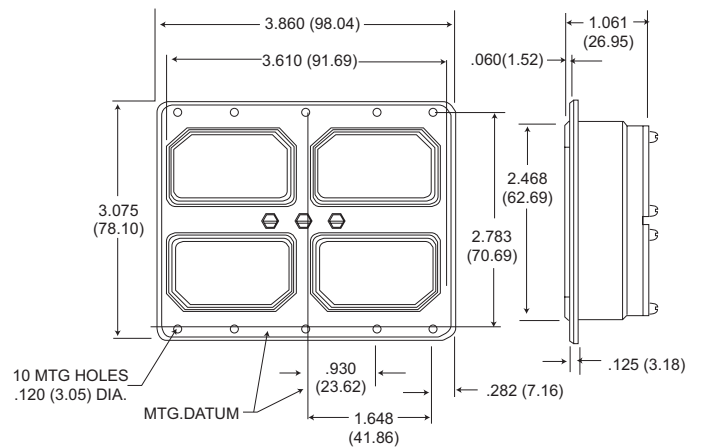

Dimensions shown in inch (mm)
Specifications and dimensions subject to change

www.ittcannon.com



Contact Arrangement Variations Solder Type (Captive Contacts)

NOTE: See pages 59-60 for Coaxial/Power Contact Termination Data

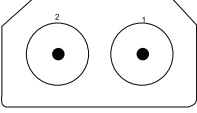
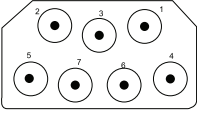
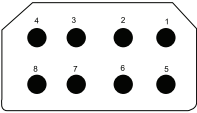
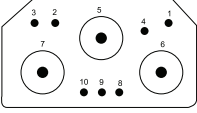
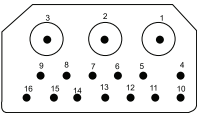
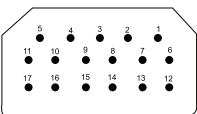
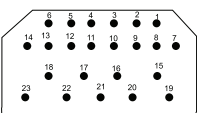
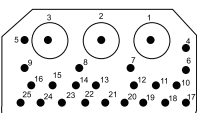
Contact Arr.	No. of Contacts & Wire size	Test Voltage AC (RMS)	PIN				SOCKET		
			Contacts Arr. No.	No. of Contacts	Contact Type Code	Contact Numbers	No. of Contacts	Contact Type Code	Contact Numbers
	2 coax (RG-9/U)	1000 (1,2)V matched impedance	C2	2	R	1-2	2	R	1-2
			C2C	2	AB	1-2	Consult Factory		
			C2M	Consult Factory			2	AC	1-2
	7 coax	1000 (1-7)V	C7	7	K	1-7	4	F	1,2,4,5
							3	G	3,6,7
			C7A	7	A	1-7	Same as Pin		
			C7B	7	B	1-7	Same as Pin		
			C7B	Same as Socket (Use C7)			7	K	1-7
			C7M	7	C	1-7	Same as Pin		
			C7X	7	AA	1-7	Same as Pin		
C7AA	7	Z	1-7	Same as Pin					
	8 #12	2000V	8	N	1-8	8	0	1-8	
	7 #20 3 coax	1500 (1-4, 8-10)V	10C3	7	L	1-4, 8-10	Same as Pin		
				3	I	5,6,7			
			A10C3	7	L	1-4, 8-10	Same as Pin		
	13 #16 3 coax	1500 (4-16)V 1000 (1-3)V	B16C3	13	M	4-16	Same as Pin		
				3	A	1-3			
			C16C3	13	M	4-16	Same as Pin		
				3	B	1-3			
			G16C3	13	M	4-16	Same as Pin		
				3	C	1-3			
			J16C3	13	M	4-16	Same as Pin		
	3	K	1-3						
ZE16C3	13	M	4-16	Same as Pin					
	3	Z	1-3						
ZF16C3	13	M	4-16	Same as Pin					
	3	AA	1-3						
	17 #20	2000V	17	17	L	1-17	Same as Pin		
	23 #20	2000 (15-23). 1500 (1-14)V.	23	23	L	1-23	Same as Pin		
	22 (#20). 3 coax	1500 (4-25)V. 1000 (1-3)V	25C3	22	L	4-25	22	L	4-25
				3	K	1-3	2	F	1,3
							1	G	2
			F25C3	22	L	4-25	Same as Pin		
				3	C	1-3			
			G25C3	22	L	4-25	Same as Pin		
				3	A	1-3			
J25C3	22	L	4-25	Same as Pin					
	3	B	1-3						
Q25C3	22	L	4-25	Same as Pin					
	3	Z	1-3						
R25C3	22	L	4-25	Same as Pin					
	3	AA	1-3						



Dimensions shown in inch (mm)
Specifications and dimensions subject to change

www.ittcannon.com

Contact Arrangement Variations Solder Type (Captive Contacts)

NOTE: See pages 59-60 for Coaxial/Power Contact Termination Data

	Contact Arr.	No. of Contacts & Wire Size	Test Voltage AC (RMS)	Contact Arr. No.	PIN		SOCKET							
					No. of Contacts	Contact Type Code	Contact Numbers	No. of Contacts	Contact Type Code	Contact Numbers				
26*		26 #16	1500V	26	26	M	1-26	Same as Pin						
30C4		15 #20. 11 #16, 4 coax	1500 (2-5 & 7-13)V 1000 (1,6 & 14-26)V	30C4	15	L	1,6 14-26	Same as Pin						
					11	M	2-5, 7-13	Same as Pin						
					4	Z	27-30	Same as Pin						
30C4		15 #20. 11 #16, 4 coax	1500 (2-5 & 7-13)V 1000 (1,6 & 14-26)V	30C4	15	L	1,6 14-26	Same as Pin						
					11	M	2-5, 7-13	Same as Pin						
					4	AA	27-30	Same as Pin						
30C4		15 #20. 11 #16, 4 coax	1500 (2-5 & 7-13)V 1000 (1,6 & 14-26)V	30C4	15	L	1,6 14-26	Same as Pin						
					11	M	2-5, 7-13	Same as Pin						
					4	A	27-30	Same as Pin						
32		3 #16 29 #20	2000 (1-6) 1500 (7-32)V	32	29	L	1,3,4,7-32	Same as Pin						
					3	M	2,5,6	Same as Pin						
32C2*		30 #20 2 coax	1500 (1-30)V 1000 (A1, A2)V	32C2	30	L	1-30	30	L	1-30				
					2	K	A1, A2	2	F	A1, A2				
					A32C2	30	L	1-30	Same as Pin					
					2	A	A1, A2	Same as Pin						
					C32C2	30	L	1-30	Same as Pin					
					2	B	A1, A2	Same as Pin						
32C2*		30 #20 2 coax	1500 (1-30)V 1000 (A1, A2)V	32C2	30	L	1-30	Same as Pin						
					2	B	A1, A2	Same as Pin						
					D32C2	30	L	1-30	Same as Pin					
					2	C	A1, A2	Same as Pin						
					M32C2	30	L	1-30	Same as Pin					
					2	Z	A1, A2	Same as Pin						
32C2*		30 #20 2 coax	1500 (1-30)V 1000 (A1, A2)V	32C2	30	L	1-30	Same as Pin						
					2	AA	A1, A2	Same as Pin						
					40		40 #20	1500V	40	40	L	1-40	Same as Pin	
										40C1	39 #20 1 coax	1500 (1-39)V 1000 (A1)V	40C1	39
					1	B	A1	Same as Pin						
					A40C1	39	L	1-39	39					L
1	K	A1	1	F	A1									
F40C1	39	L	1-39	Same as Pin										
1	C	A1	Same as Pin											
40C1		39 #20 1 coax	1500 (1-39)V 1000 (A1)V	40C1	39	L	1-39	Same as Pin						
					1	Z	A1	Same as Pin						
					K40C1	39	L	1-39	Same as Pin					
1	AA	A1	Same as Pin											
L40C1	39	L	1-39	Same as Pin										
1	A	A1	Same as Pin											
45*		45 #20	1500V	45	45	L	1-45	Same as Pin						
					57*		57 #20	1500V	57	57	L	1-57	Same as Pin	
67*		64 #20 3 #16	1000V	67						64	L	1-2,6-65	Same as Pin	
					3	M	3-5	Same as Pin						

Dimensions shown in inch (mm)
 Specifications and dimensions subject to change
 www.ittcannon.com



Contact Arrangement Variations, Crimp Type - DPX*MA/ME Series

NOTE: See pages 62-65 for Coaxial Contact data
See pages 57-58 for Crimp Contact data

	Contact Arr.	No. of Contacts & Wire Size	Test Voltage AC (RMS)	Contact Arr. No.	No. of Contacts	Contact Size or Code Letter	Contact Numbers
8		8 #12		8	8	12	1-8
D8		4 #16, 4 #12		D8	4	16 12	1-4 5-8
W8**		8 coax	1000V (1-8)V	W8 C8A C8B C8C C8E C8G C8H	8	coax G F H R S AB	1-8
10		2 #8, 8 #20	1500V	10	2 8	B 20	1,2 3-10
A10		8 #16, 2 #4	1500V	A10	8 2	16 4	1-3, 5, 6, 8-10 4, 7
10W3**		7 #20, H.D., 3 coax	1500 (1-4, 8-10)V	10W3 A10C3 B10C3	7 3 7 3 7 3	20 H.D. coax 20 H.D. AC 20 H.D. AC	1-4, 8-10 5-7
B16W3**		SOCKET ONLY B16W3	1500 (4-16) 1000 (1-3)V socket side only (Not available in ME series)	B16W3	13 3	16 coax	4-16 1-3
25W3		22 (#20) 3 coax	1500 (4-25)V, 1000 (1-3)V (Not available in ME series)	25W3 25A3 25B3 25D3	22 3 22 3 22 3	20 coax 20 C 20 D 20 B	4-25 1-3
26		26 #16	1500V	26	26	16	1-26

**Crimp rear release coaxial contacts.



Dimensions shown in inch (mm)
Specifications and dimensions subject to change

www.ittcannon.com

Contact Arrangement Variations, Crimp Type - DPX*MA/ME Series

NOTE: See pages 62-65 for Coaxial Contact data
See pages 57-58 for Crimp Contact data

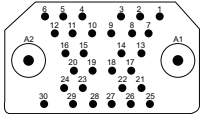
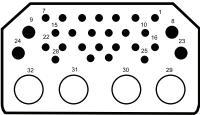
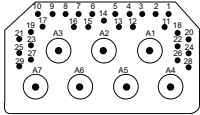
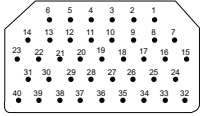
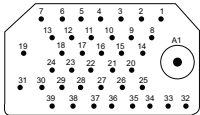
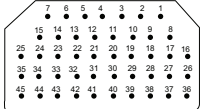
Contact Arr.	No. of Contacts & Wire Size	Test Voltage AC (RMS)	Contact Arr. No.	No. of Contacts	Contact Size or Code Letter	Contact Numbers			
32W2 	32W2** (For MA) A32W2 (For ME) 30 #20, 2 coax	1500 (1-30), 1000 (A1,A2)V	32W2	30 2	20 coax				
			32A2	30 2	20 B				
			32B2	30 2	20 A				
			32C2	30 2	20 D	1-30 A1,A2			
			D32C2	30 2	20 J				
			32F2	30 2	20 P				
			32G2	30 2	20 C				
			32W4 	32W4** (For MA) A32W4 (For ME) 24 #20 H.D. 4 #16, 4 coax	1500 (1-28), 1000 (29-32)V	32W4	4 24 4	coax 20 H.D. 16	
32C4	4 24 4	S 20 H. D. 16							
B32C4	4 24 4	H 20 H. D. 16							
C32C4	4 24 4	R 20 H. D. 16				29-32 1-7, 10-22 25-28 8, 9, 23, 24			
D32C4	4 24 4	G 20 H. D. 16							
E32C4	4 24 4	AA 20 H. D. 16							
H32C4	4 24 4	AB 20 H. D. 16							
36W7 	36W7** 29 #22 7 coax (Size 5)	1000							
40 	40 40 #20	1500V				40	40	20	1-40
40W1 	40W1** (For MA) A40W1 (For ME) 39 #20, 1 coax	1500 (1-39) 1000 (A1)V	40W1	39 1	20 coax				
			40B1	39 1	20 B	1-39 A1			
			40F1	39 1	20 P				
			F40C1	39 1	20 J				
45 	45 45 #20	1500V	45	45	20	1-45			

**Crimp rear release coaxial contacts.

Dimensions shown in inch (mm)
Specifications and dimensions subject to change

www.ittcannon.com



Contact Arrangement Variations, Crimp Type - DPX*MA/ME Series

NOTE: See pages 62-65 for Coaxial Contact data
See pages 57-58 for Crimp Contact data

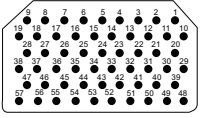
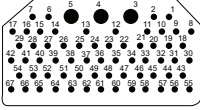
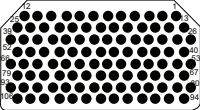
	Contact Arr.	No. of Contacts & Wire Size	Test Voltage AC (RMS)	Contact Arr. No.	No. of Contacts	Contact Size or Code Letter	Contact Numbers
57		57 #20	1500V	57	57	20	1-57
67		64 #20 H.D. 3 #16	1500 (3-5) 1000 (1, 2, 6-67)V	67	64 3	20 H.D. 16	1-2, 6-67 3, 4, 5
A106†		A106† 106 #22	1000V	A106	106	22	1-106

**Crimp rear release coaxial contacts.

†A106 arrangements have the POS-ALINE connector design. See below.

NOTE: Engaging force of each layout arrangement shall not exceed 45 lbs. maximum.

Positive Contact Alignment Design

For high density A106 contact arrangement

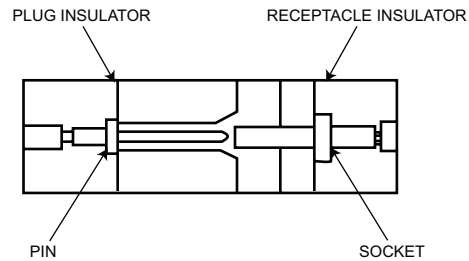

In the POS-ALIGN connector construction the entire pin contact is recessed in an individual cavity in the plug insulator while the sturdy socket members are exposed and extend from the connector receptacle face. There is a lead-in chamfer that guides the socket contact into the pin cavity assuring proper contact alignment during mating and protecting the pin contact from damage and wear.



Contact and Termination Tooling Data - Commercial

Crimp Contacts

The crimp contacts are shipped with the connector, not installed. Additional contacts may be ordered using the part numbers listed below. All tools must

be purchased separately. The insertion/extraction tools listed are plastic type. Consult factory for more durable metal tools.

Contact Size	Type	Part Number		Wire Accom.	Crimp Tool Part Number	Locator Part Number	Insertion/Extraction Tool (Part No.)	Layout Usage	
		DPX MA Commercial	DPX ME Commercial [△]					DPX ME	DPX MA
2222	Pin	030-1975-007	030-1975-005	22,24,26	M22520/2-01	M22520/2-23	CIT-DPXMA-22 M81969/1-01	A106	A106
	Socket	031-1113-007	031-1113-008						
2020	Pin	030-9081-000	030-2040-000	20,22,24	M22520/2-01 MS-3191-1 MS-3191-3	M22520/2-02 Std. Locator M22520/2-01 Std. Locator	CIET-20 (274-7001-000)	10, A32W2, 40, A40W1, 45,57	10, 25W2, 32W2 40, 40W1, 45,57
	Socket	031-9134-001	031-1046-002						
2020HD	Pin	030-9081-003	030-1892-002	20,22,24	M22520/2-01 MS-3191-1	M22520/2-08 Standard	CIET-20 M81969/1-02 (980-0004-805)	10W3 A32W4, 67	10W3 32W4, 67
	Socket	031-9134-004	031-1047-002						
1616	Pin	030-9083-001	030-1893-002	16,18,20	M22520/1-01 MS-3191-1	M22520/1-02 Std. Locator	CIET-16 (274-7002-000)	D8, A10, 26, A32W4, 67	D8, A10, 26, B16W3, 32W4, 67
	Socket	031-9206-004	031-9206-021						
1212	Pin	030-1909-001	030-2045-000	12,14	M22520/1-01	M22520/1-11	CIET-12 (274-7003-000)	D8	8, D8
	Socket	031-1059-001	031-1059-002						
0808	Pin	030-1908-001	030-1908-001	8	CBT-600* CBT600B*	CCH8-1 Head CCHP-8-6	CET-8-2 (323-7004-000)	10	10
	Socket	031-1154-000	031-1154-000						
0406	Pin	030-2049-000	030-2049-000	6	CBT-600* CBT600B*	CCH4-1 Head CCHP-4-8	CET-4-8 (323-7008-000)	A10	A10
	Socket	031-1151-000	031-1151-000						

* Requires air line pressure of 80 to 100 psi.

These DPXME contacts are being superseded in favor of military DPXNE/NA contacts, this applies to all existing DPXME connector assemblies, except for size 20 contacts.

Electrical Data

Contact Size	Wire Size	Insulation (O.D.) Limits Inch (mm) Max.	Test Current per MIL-C-39029 Table VI	Max. Current for Tests (Amps) (Mil-C-39029)	Max. Potential Drop (Millivolts) at 25°C per MIL-C-39029
4	6	.310 (7.87)	60	60	33
8	8	.250 (6.35)	46	46	39
12	12	.135 (3.43)	23	23	63
	14		17	17	60
	16		13	13	68
16	18	.103 (2.62)	-	-	-
	20		7.5	-	75
	20		7.5	7.5	83
20	22	.071 (1.80)	-	-	-
	24		3	3.0	68
22	22	.054 (1.37)	5	5.0	110
	24		-	-	-
	26		2	2.0	80

Dimensions shown in inch (mm)
Specifications and dimensions subject to change

www.ittcannon.com



Description of Modification Codes for Special Connector Insert Assemblies

Class	Series	DPX Insert Type	Class	Series	DPX Insert Type	Class	Series	DPX Insert Type
None	DPXA DPXB	Two (2) pieces, solder pot.	D*	-	(MA) LITTLE CAESAR assembly, crimp pot, (Cat. A)	DPX2CA-/	-	A side: (MAS) LITTLE CAESAR assembly, solder pot (32W2S)
MA	DPXAMA DPXBMA	LITTLE CAESAR rear release contact retention assembly, crimp pot.	E*	-	Metal plates.	DPX2AC- (Reverse CA)	-	B side: Standard 2 Piece, solder pot (57S). Ex: DPX2CA-32W2S57S-33-0001
MAS	-	LITTLE CAESAR assembly, solder pot,	DPX2-	-	Standard 2 pieces, solder pot, both sides, Ex: DPX2-57S57S-33-0001	DPX2AF	-	A side: Standard solder pot. B side: Rear release crimp with separator. Ex: DPX2AF-13S26S-33B-0001
MB	-	LITTLE CAESAR rear release contact retention assembly, crimp pot, with separator.	DPX2MA	-	Standard LITTLE CAESAR assembly, crimp pot both sides Ring-loc coax. EX:DPX2MA-57S57S-33-0001	DPX2BA	-	A side: Ring-Loc solder pot (40W1S). B Side: 2 Piece, Solder Pot (57S). Ex: DPX2BA-40W1S57S-33-0001
MS	-	Ring-Loc, solder pot,	DPX2MAS	-	LITTLE CAESAR assembly, solder pot, both sides Ring-Loc coax. EX: DPX2MAS-57S57S-33-0001	DPX2DA	-	A side: (MA) LITTLE CAESAR assembly, Crimp (67S). B Side: 2 Piece, solder pot (57S). Ex: DPX3DA-67S57S-33-0001
ME	-	Environmental, connector.	DPX2MS-	-	Ring-Loc, solder pot. Layout 25C3 pin only and 40C1 Pin and socket. EX: DPX2MS-40W1S40W1S-33-0001	DPX2EB	-	A side: Metal plates for grounding (Coaxes). B side: Ring-Loc, solder pot. Ex: DPX2EB-C1P40W1P-34B-0001
A*	-	Two (2) pieces, solder pot (Standard 2 pieces insert).						
B*	-	Ring-Loc, solder pot. (See MS)						
C*	-	(MAS) LITTLE CAESAR assembly, Solder pot.						

*NOTE: When any two of these letters are used in combination, the inserts ("A" and "B") side have the style contacts indicated (see table opposite for examples).

Contact and Termination Tooling Data

DPXMA (LIF) Crimp Contacts

Contact Size and Part Numbers			Crimp Tooling						Insertion/Extraction Tooling			Wire Size		
Part Number			Tool P/N		Locator P/N			ITT Cannon			AWG	Insul Dia. Max.	Strip Length	
Size	Pin	Socket	MIL Spec	ITT Cannon	Selec tor#	MIL Spec	ITT Cannon	MIL Spec	Insertion	Extraction				Ins./Ext.
222	030-2259-000	031-1287-000	M22520 /2-01	995-0001 -584	3	M22520 2-23	995-0002 -015	M81969 /1-01	CIT-DPXMA-22-1 Metal (070256-0000)	CET-DPXMA-22 Metal (070317-0000)	(980-0004-804) Metal Tip	26	.054 (1.37)	.130/.110 (3.30/2.54)
					3							24		
					4							22		
2020HD	030-2273-000	031-1302-000	M22520 /2-01	995-0001 -584	6	M22520 /2-08	995-0001 -604	M81969 /1-02	-	-	(980-0004-805) Metal Tip	22	.071 (1.80)	.167/.147 (4.24/3.73)
					7							20		
1616	030-2280-000	031-1303-000	M22520 1-01	995-0001 -585	4	M22520 /1-02	995-0001 -736	M81969 /1-03	-	CET-16-9 Plastic (323-7001-0000)	(980-0004-806) Metal Tip	20	.103 (2.62)	.270/.230 (6.86/5.84)
					5							18		
					6							16		
1212	030-2286-000	031-1308-000	M22520 1-01	995-0001 -585	7	M22520 /1-11	995-0002 -027	M81969 /14-04	-	CET-12-4 Plastic (323-7002-0000)	CIET-12 Plastic (274-7003-0000)	14	.135 (3.43)	.270/.230 (6.86/5.84)
					8							12		

DPXMA Thermocouple Contacts

Contact Size and Part Numbers			Crimp Tooling						Insertion/Extraction Tooling			Wire Size		
Part Number			Tool P/N		Locator P/N			ITT Cannon			AWG	Insul Dia. Max.	Strip Length	
Size	Pin	Socket	MIL Spec	ITT Cannon	Selec tor#	MIL Spec	ITT Cannon	MIL Spec	Insertion	Extraction				Ins./Ext.
2222 Alumel	030-1975-009	031-1113-009	M22520 /2-01	995-0001 -584	3	M22520 /2-23	995-0002 -015	M81969 /1-01	CIT-DPXMA-22-1 Metal (070256-0000)	CET-DPXMA-22 Metal (070317-0000)	(980-0004-804) Metal Tip	26	.054 (1.37)	.130/110 (3.30/2.54)
2222 Chromel	030-1975-010	031-1113-010			4							22		



Dimensions shown in inch (mm)
Specifications and dimensions subject to change

www.ittcannon.com

Coaxial/Power Contact Termination Data (Retained by Captive Insulator Assy.)

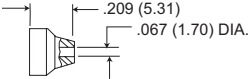
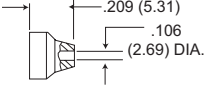
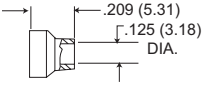
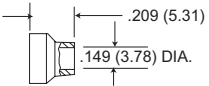
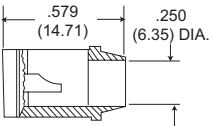
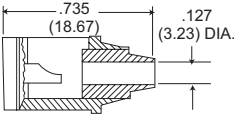
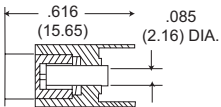
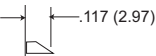
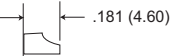
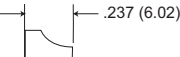
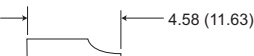
Rear Extension from insulator	Contact type code	Part Number		Cable Accommodation	Layout Accommodation
		Pin	Socket		
	A	249-0672-000	249-0671-000	RG-187/U RG-188/U	C7A, B16C3, G25C3, C30C4, A32C2, L40C1
	B	249-0702-000	249-0703-000	RG-180/U RG-195/U	C7B, J25C3, C16C3, C32C2, 40C1
	C	249-0749-000	249-0750-000	RG-55/U RG-58/U RG-223/U	C7H, G16C3, F25C3, D32C2, F40C1
	D	-	249-0518-000	RG-59/U	C7J, H16C3, H25C3, F32C2, E30C4, E40C1
	I	249-0365-000	249-0353-000	RG-7/U	10C3
	J	249-0257-000	249-0268-000	RG-55/U RG-58/U RG-223/U	A10C3
	K	249-0583-000 024-0015-000 253-0120-000	249-0591-000 024-0015-000 253-0120-000	RG-187/U RG-188/U	25C3, 32C2, J16C3, A40C1, C7, C7D
					A40C1 pin only, use C40C1 for socket
	L	330-0144-000	330-0145-000	7.5 amp #20 wire	See Note 1
	M	030-0056-010	031-0016-008	13 amp #16 wire	See Note 2
	N	030-0017-015	-	23 amp	8
	O	-	031-0059-008	#12 wire	8

* These coaxial contacts are supplied with the connector.

Dimensions shown in inch (mm)
Specifications and dimensions subject to change

www.ittcannon.com

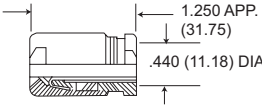
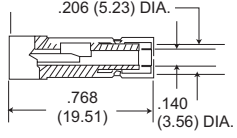
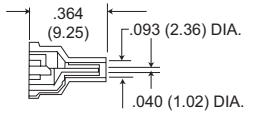
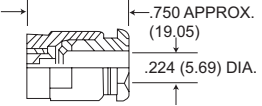
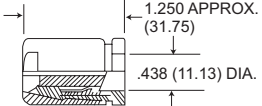

Coaxial/Power Contact Termination Data (Retained by Captive Insulator Assy.)

Rear Extension from insulator	Contact type code	Part Number		Cable Accommodation	Layout Accommodation
		Pin	Socket		
	R	249-1521-000	249-1522-000	RG-9/U, RG-214/U	C2
	Z	249-1624-000	249-1598-000	RG-58/U with Captive Contact	C7AA, ZE16C3, Q25C3, A30C4, M32C2, J40C1
	AA	249-1599-000	249-1622-000	RG-196/U with Captive Contact	C7X, ZF16C3, R25C3, B30C4, N32C2, K40C1
	AB	249-1554-000	249-1822-000	RG-58/U	C2C
	AC	Consult Factory	249-5027-001	RG-9/U, RG-214/U	C2M

NOTES: 1. Code L-10C3, A10C3, 17, 23, 25C3, E25C3, F25C3, G25C3, H25C3, J25C3, Q25C3, R125C3, 30C4, A30C4, C30C4, D30C4, E30C4, 32, 32C2, A32C2, C32C2, 032C2, F32C2, M32C2, N32C2, Q32C2, 40, 40C1, B40C1, D40C1, E40C1, F40C1, H40C1, J40C1, K40C1, L40C1, 45, 57, 67, 2. Code M-B16C3, C16C3, G16C3, H16C3, M16C3, ZE16C3, ZF16C3, 26, 30C4, 32, 67

Suggested Cable Trim Dimensions

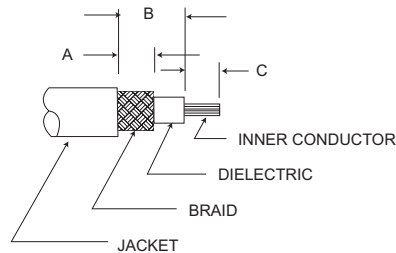

Code Letter	Inches			Millimeters		
	A	B	C	A	B	C
A	.166/.146	.358/.318	.14	4.22/3.71	9.08/8.08	3.55
B	.166/.146	.358/.318	.14	4.22/3.71	9.08/8.08	3.55
C	.166/.146	.358/.318	.14	4.22/3.71	9.08/8.08	3.55
D	.166/.146	.358/.318	.14	4.22/3.71	9.08/8.08	3.55
E	.166/.146	.358/.318	.14	4.22/3.71	9.08/8.08	3.55
I	.166/.146	.39	.166/.146	4.22/3.71	9.91	4.21/3.71
J	.166/.146	.55	.166/.146	4.22/3.71	13.97	4.21/3.71
K	.198/.178	.488/.428	.25	5.03/4.52	11.38/10.87	6.35
Z	.08	.41	.23	2.03	10.41	5.84
AA	.11	.23	.195/.175	2.79	5.84	4.95/4.45
AB	.238/.198	.233/.193	.447/.427	6.04/5.03	5.92/4.90	11.35/10.89
AC	.345/.281	.516/.484	.359/.296	8.71/7.14	13.1/12.3	9.12/7.52
R	.238/.198	.233/.193	.582/.542	6.05/5.03	5.92/4.90	14.8/13.8



Dimensions shown in inch (mm)
Specifications and dimensions subject to change

www.ittcannon.com

Coaxial Cable Assembly

ITT Cannon recommends resistance soldering for all solder contacts, particularly for RF cable where excessive heat will damage the dielectric. Wires

should be pre-tinned. Bushing, endbells, and junction shells (where applicable) must be slipped over wire bundles before soldering is started. Consult

factory for types not shown. The mechanical steps in wiring coaxials described below.

For Codes A, B, C, D, and E

1. Cut cable evenly. Trim to dimensions as shown on page 60. Care should be taken not to injure the conductor or dielectric.
2. Remove inner contact from coaxial assembly and solder it to inner conductor of cable.
3. Push inner contact back into coaxial assembly.
4. Pull outer conductor over coaxial shell, and solder.
5. Apply shrink sleeving after assembly.

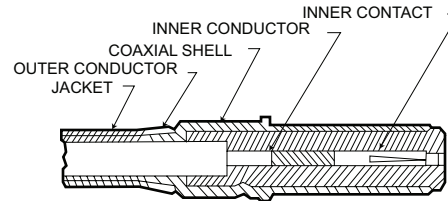

For Codes I and J

1. Cut cable evenly. Trim to dimensions as shown on page 60. Care should be taken not to injure the conductor or dielectric.
2. Comb braid, tin conductor and remove flux.
3. Remove solder pot cover. Insert cable and solder conductor to contact. The dielectric should butt against contact solder pot.
4. Replace solder pot cover and solder braid to ferrule.
5. Apply shrink sleeving after assembly.

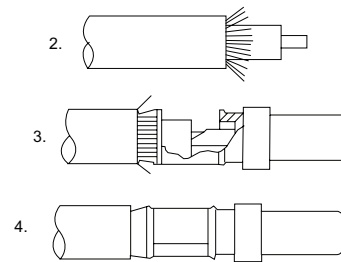

For Codes K

1. Cut cable evenly. Trim to dimensions as shown on page 60. Care should be taken not to injure the conductor or dielectric.
2. Unscrew cap and remove spacer and inner contact from coaxial assembly.
3. Push cable through center of cap and spacer.
4. Solder inner contact to inner conductor of cable.
5. Push inner contact back into coaxial shell assembly and attach cap.
6. Separate outer conductor of cables into two pigtailed 180° apart.
7. Attach on pigtail to each end of cap strip and solder.
8. Apply shrink sleeving after assembly.

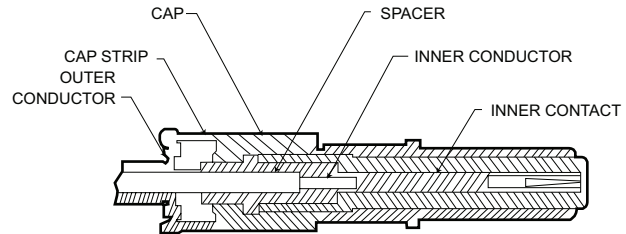

For Codes Z and AA

1. Cut cable evenly. Trim to dimensions as shown on page 60. Care should be taken not to injure the conductor or dielectric.
2. Solder inner conductor to coaxial contact through side slot in coaxial with outer sleeve pushed back on cable.
3. Pull sleeve forward over braid and solder through holes in sleeve.
4. Solder sleeve to coaxial body.

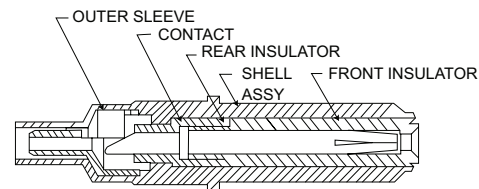

Dimensions shown in inch (mm)
Specifications and dimensions subject to change

www.ittcannon.com



Coaxial Contacts

NOTES: 1. The "X" dimension is taken from the rear of the shell.
 2. Codes G and S are inactive for new design. Use codes AD and AE.
 3. Code AA is designed for installations that have limited space in the terminal area. Use code AG for standard installations.

*P for pin; S for socket.

Codes A, B, C, D, E, H, P, R

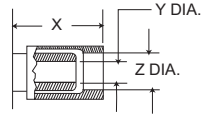

Arr. Used In	Code Letter	Cable Accommodation	Part Number*	Contact Retention	X Max.	Y Dia.	Z Dia.	Crimp Tool	Extraction Tool
B16W3 25W3 32W2 40W1	A	*RG-59/U	P-249-1397-000	Ring Loc	.760 (19.30)	.158 (4.01)	.275 (6.53)	CA58073	CET-C4 (038869-0004)
		RG-62/U	S-249-1398-000	Ring Loc	.760 (19.30)	.148 (3.76)	.247 (6.27)		
	B	*RG-58/U	P-249-1399-000	Ring Loc	.760 (19.30)	.128 (3.25)	.211 (5.36)		
			S-249-1400-000	Ring Loc	.760 (19.30)	.118 (3.00)	.201 (5.10)		
	C	*RG-180/U	P-249-1401-000	Ring Loc	.760 (19.30)	.128 (3.25)	.166 (4.22)		
RG-195/U	S-249-1402-000	Ring Loc	.760 (19.30)	.118 (3.00)	.156 (3.96)				
D	RG-174/U, RG-187/U	P-249-1403-000	Ring Loc	.760 (19.30)	.072 (1.83)	.121 (3.07)	CCT-HX4-524 CCT-408M		
	RG-179/U, RG-188/U	S-249-1404-000	Ring Loc	.760 (19.30)	.062 (1.57)	.111 (2.82)			
E	RG-178/U	P-249-1405-000	Ring Loc	.760 (19.30)	.072 (1.83)	.091 (2.31)	CCT-HX4-524 CCT-408M		
	RG-196/U	S-249-1406-000	Ring Loc	.760 (19.30)	.062 (1.57)	.081 (2.06)			
W8 32W4	H	RG-174/U, RG-187/U	P-249-1633-000	LITTLE	.592 (15.04)	.072 (1.83)	.121 (3.07)	CCT-HX4-524 CCT-408M	CET-C8 (323-7011-000)
		RG-179/U, RG-188/U	S-249-1634-000	CAESAR	.592 (15.04)	.062 (1.57)	.111 (2.82)		
B16W3 25W3 32W2 40W1	P	*RG-58/U with nylon braid over jacket	S-249-1608-000	Ring Loc	.760 (19.30)	.128 (3.25)	.235 (5.97)	Crimp CA58073	CET-C4 (038869-0004)
W8 32W4	R	*RG-178/U	P-249-1670-000	LITTLE	.592 (15.04)	.072 (1.83)	.091 (2.31)	CCT-HX4-524 CCT-408M	CET-C8 (323-7011-000)
		RG-196/U	S-249-1671-000	CAESAR	.592 (15.04)	.062 (1.57)	.081 (2.06)		

*IMPORTANT: These coaxials can only be used in the DPX*MAS or DPX*MB Connector Series.

Codes F, S, T

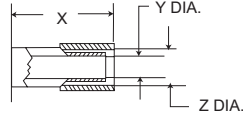

W8 32W4	F	RG-59/U	P-249-1474-000	LITTLE	.775 (19.68)	.158 (4.01)	.238 (6.04)	CA58073	CET-C8
		RG-62/U	S-249-1471-000	CAESAR	.775 (19.68)	.148 (3.76)	.228 (5.79)	CCT-HX3-156	(323-7011-000)
	S	RG-55/U	P-249-1958-000	LITTLE	.592 (15.04)	.130 (3.30)	.238 (6.04)	CA58073	CET-C8 (323-7011-000)
		RG-142/U	S-249-1959-000	CAESAR	.592 (15.04)	.120 (3.05)	.228 (5.79)		
T	RG-59/U	P-249-1960-000	LITTLE	.592 (15.04)	.158 (4.01)	.238 (6.04)	CCT-HX3-156	(323-7011-000)	
	RG-62/U	S-249-1961-000	CAESAR	.592 (15.04)	.148 (3.76)	.228 (5.79)			

Codes G

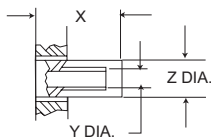

W8 32W4	G	RG-58/U	P-249-1631-000	LITTLE	.500 (12.70)	.130 (3.30)	.211 (5.36)	CCT-HX4-524 CCT-408M	CET-C8 (323-7011-000)
			S-249-1632-000	CAESAR	.500 (12.70)	.120 (3.05)	.201 (5.10)		

Codes J

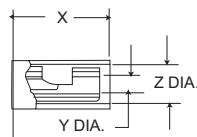

W16W3 25W3 32W2 40W1	J	RG-58/U	P-249-1388-000	Ring Loc	.798 (20.27)	.130 (3.30)	.273 (6.93)	Solder	CET-C4 (038869-0004)
			S-249-1390-000	Ring Loc	.798 (20.27)	.120 (3.05)	.263 (6.68)		

Dimensions shown in inch (mm)
 Specifications and dimensions subject to change



Coaxial Contacts

CODE K

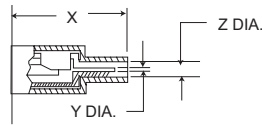

Arr. Used In	Code Letter	Cable Accommodation	Part Number*	Contact Retention	X Max.	Y Dia.	Z Dia.	Crimp Tool	Extraction Tool
B16W3 25W3 32W2 40W1	K	RG-178/U	P-249-1384-000	Ring Loc	.906 (23.01)	.045 (1.14)	.098 (2.49)	Solder	CET-C4 (038869-0004)
		RG-196/U	S-249-1413-000						

CODE L

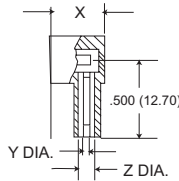

B16W3 25W3 32W2 40W1	L	RG-178/U	P-249-1386-000	Ring Loc	.518 (13.16)	.045 (1.14)	.098 (2.49)	Solder	CET-C4 (038869-0004)
		RG-196/U	S-249-1414-000						

CODE U

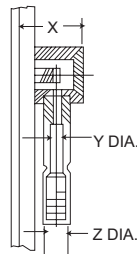

W8	U	RG-174/U, RG-187/U	S-249-1883-000	LITTLE CAESAR	.425 (10.80)	.069 (1.75)	.117 (2.97)	CCT-C10	CET-C8 (038869-0004)
		RG-179/U, RG-188/U				.059 (1.50)	.107 (2.72)		

CODE V, AC

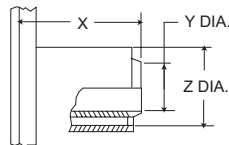

10W3	V	RG-115/U	P-249-1956-000	LITTLE CAESAR	.800 (20.32)	.260 (6.60)	.356 (9.04)	Buchanan 612991	CET 4-8 (323-7008-000)
			S-249-1957-000			.254 (6.45)	.349 (8.86)		
	AC	RG-58/U	S-249-1977-000	LITTLE CAESAR	.800 (20.32)	.205 (5.21)	.356 (9.04)		
						.199 (5.05)	.349 (8.86)		

CODE AA, AB, AD, AE, AF, AG

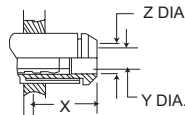

W8 32W4	AA	RG-178/U	P-249-1968-000	LITTLE CAESAR	.260 (6.60)	.088 (2.24)	.126 (3.20)	T & B #WT400		
		RG-196/U				.084 (2.13)	.122 (3.10)			
	AB	RG-180/U	P-249-1982-000							
		RG-195/U	S-249-1983-000							
	AD	RG-58/U	P-249-2017-000							
			S-249-2018-001							
	AE	RG-142/U	P-249-2019-001		LITTLE CAESAR	.575 (14.60)	.114 (2.90)	.168 (4.27)	Daniels HX4-210	CET-C8 (323-7011-000)
			S-249-2020-001				.104 (2.64)	.158 (4.01)		
	AF	RG-174/U, RG-187/U	P-249-1633-004							
		RG-179/U, RG-188/U	S-249-1634-003							
	AG	RG-178/U	P-249-2061-000							
		RG-196/U	S-249-2062-001							

Dimensions shown in inch (mm)
Specifications and dimensions subject to change



DPX*MA/ME Coaxial Contact Data (for environmental requirements)

Components/Accessories

NOTE: The A32W2 & A40W1 (Ring Type Retention); AW8 & A32W4 (LITTLE CAESAR Renention) Coaxial Contact arrangements have been redesigned to provide ease of insertion/removal of the coaxial contacts. Sealing is accomplished with the addition of sealing sleeves provided with the coaxial contact assembly.

RING TYPE RETENTION (A32W2 & A40W1 CONTACT ARRANGEMENTS)

Part Number*		Cable Accommodation		Ins. Dia. Size/Max.	'A' Trim Dim.	Crimp Tool
Without Seal (MA)	Sealed (ME)	Seal 1	Seal 2			
P-249-1397-001	P-249-1397-002	X	RG59B, RG62A	.249 (6.32)	.435 (11.05)	CA58073
S-249-1398-003	S-249-1398-002				.415 (10.54)	
P-249-1399-001	P-249-1399-002	RG58B	X	.200 (5.08)	.460 (11.68)	CA58073
S-249-1400-003	S-249-1400-002				.440 (11.18)	
P-249-1401-001	P-249-1401-002	RG195	RG180B	.158 (4.01)]	.460 (11.68)	CA58073
S-249-1402-003	S-249-1402-002				.440 (11.18)	
P-249-1403-001	P-249-1403-002	RG179B	RG174, RG179B,	.113 (2.87)	.460 (11.68)	CCT-406M
S-249-1404-003	S-249-1404-002		RG316		.440 (11.18)	
P-249-1405-001	P-249-1405-002	RG179B, RG196	X	.083 (2.11)	.480 (12.19)	CCT-406M
S-249-1406-003	S-249-1406-002				.460 (11.68)	

*P for pin, S for socket

†Unsealed accommodates both Seal 1 & Seal 2 Cables.

††For use with connectors supplied less grommet (Code 29**, etc.)

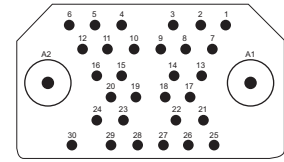

32W2 (MA Version)
A32W2 (ME Version)

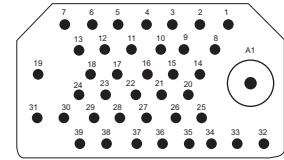

40W1 (MA Version)
A40W1 (ME Version)

Cable Trim
Dimensions

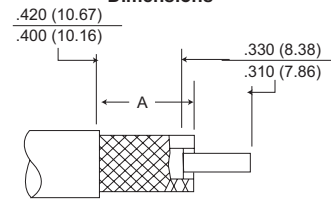

Coaxial Contact Assembly Recommendations

(For Codes A, B, C, D, E, J, K, L and P)

- Center contact, rear insulator, crimp ring, support bushing and seal sleeve are packaged separately and shipped with the coaxial assembly.
- Use impact extraction tool no. CET-C4 (038869-0004). An insertion tool is not required. (See Item 4).
- Cable Assembly Instructions
 - Step 1- If applicable, determine which portion of seal sleeve should be used. If seal 2 is used, cut off seal 1 portion
 - Step 2 - In sequence, place seal sleeve, support bushing and crimp ring over cable jacket.
 - Step 3 - Trim cable per illustration.
 - Step 4 - Place rear insulator over dielectric.
 - Step 5 - Solder innerconductor to center contact.
 - Step 6 - Insert soldered cable firmly into coaxial with shielding over coaxial shell.
 - Step 7 - Pull crimp ring forward until stopped and crimped.
 - Step 8 - Insert coaxial assembly into connector until engaged. Push support bushing into grommet until shoulder rest on tubular extension. Then pull seal sleeve forward until it is snug against grommet.
- To extract coaxial, push back seal sleeve and support bushing. Then push out coaxial from engaging end with CET-C4 (038869-0004) impact tool.
- When crimping with CA58073 crimp tool, care should be taken to avoid flaring the front end of the crimp ring. Place Crimp jaw so that the second tooth of the indentors is over the end of the crimp ring.
- To facilitate extraction of contacts and avoid splaying the length of free cable adjacent to the rear surface of the connector should not be less then 2.000 (50.80).

WITHOUT SEAL

(For Codes A, B, C, D, E, J, K, L and P)



SOCKET



PIN

SEALED

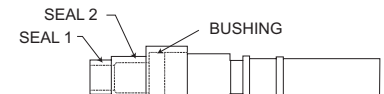

SOCKET

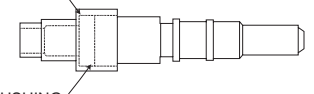

PIN



Dimensions shown in inch (mm)
Specifications and dimensions subject to change

www.ittcannon.com

DPX*MA/ME Coaxial Contact Data (for environmental requirements)

Components/Accessories

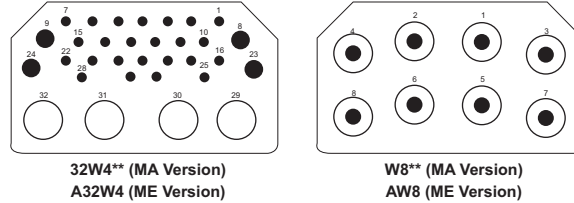

Cable Trim Dimensions

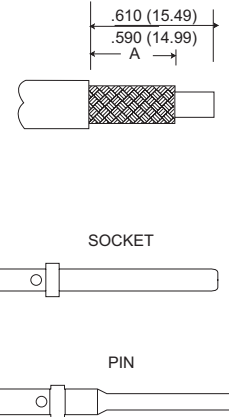

LITTLE CAESAR® CONTACT RETENTION (A32W4 & AW8 CONTACT ARRANGEMENTS)

Part Number*		Cable Accommodation†		Ins. Dia. Size/Max.	'A' Trim Dim.
Without Seal†† (MA)	Sealed (ME)	Seal 1	Seal 2		
P-249-1633-004	P-249-1633-003	RG179	RG174, RG316,	.111 (2.82)	.350 (8.89)
S-249-1634-003	S-249-1634-002		RG179B		
P-249-1982-000	P-249-1982-001	RG180B	RG195	.158 (8.89)	.260 (6.60)
S-249-1983-000	S-249-1983-001				
P-249-2017-001	P-249-2017-000	RG58C	X	.196 (4.98)	.260 (6.60)
S-249-2018-001	S-249-2018-000				
P-249-2019-001	P-249-2019-000	RG142B	X	.196 (4.98)	.260 (6.60)
S-249-2020-001	S-249-2020-000				
P-249-2061-001	P-249-2061-000	RG178B	X	.075 (1.90)	.260 (6.60)
S-249-2062-001	S-249-2062-000				

*P for Pin, S for Socket
 †Unsealed accommodates both Seal 1 & Seal 2 cables.
 ††For use with connector supplied less grommet (Code-29**, etc.).

Coaxial Contact Assembly and Extraction Recommendations

- Use Crimp Tool No. DIE Y211 (995-0002-249), Tool M22520 / 5-01 (995-0001-761).
- Use extraction tool No. CET-C8. An insertion tool is not required. (See Note 5).
- Center contact, rear insulator, crimp ring, support bushing (not applicable to RG58/RG142 coaxials), seal sleeve, front insulator, shell and ferrule are shipped unassembled in a common container.
- Cable Assembly Instructions:
 - Step 1 - If applicable, determine which portion of seal sleeve should be used. If seal 2 is used, cut off seal 1 portion.
 - Step 2 - In sequence, place seal sleeve, support bushing and crimp ring over cable jacket.
 - Step 3 - Trim cable per illustration.
 - Step 4 - Comb out braid and flare out ends to permit entry of ferrule.
 - Step 5 - Complete termination per illustration. (See below)
- To extract: coaxial, push back seal sleeve and support bushing. Slip cable into extraction tool. Push tool into insert until it contacts coaxial retaining shoulder. Grip both cable and tool with one hand and pull coaxial rearward out of insert cavity.

WITHOUT SEAL

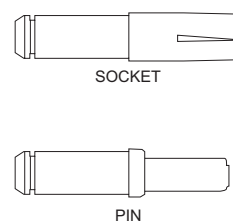

SEALED

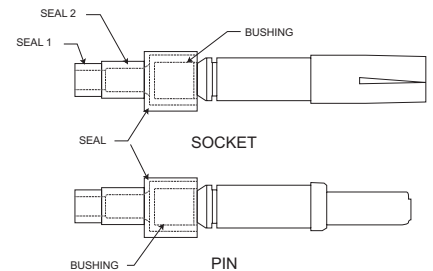

- To facilitate extraction of contacts and avoid splaying, the length of free cable adjacent to the rear surface of the connector should not be less than 2.000 (50.80).

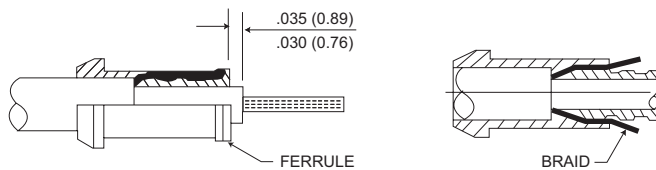

- Carefully push inner conductor through rear insulator.
- While holding rear insulator firmly against ferrule, trim conductor to .156 (3.96)/.146 (3.71) dimension.
- Place contact over conductor and solder.

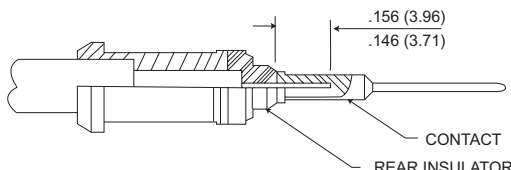

- Push ferrule under braid as far as it will go. Trim off braid extending beyond shoulder of ferrule, if necessary.
- While holding ferrule in place pull crimp sleeve forward over braid until it is tight against shoulder of ferrule. Pull firmly against face of ferrule to make sure it is up tight.
- Trim dielectric to the .035 (0.89)/.030 (0.76) dimension.

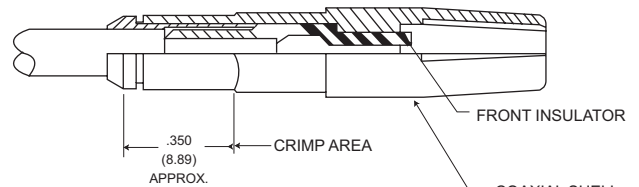

- Place front insulator over contact and then push assembly into coaxial shell.
- Place parts in jaw of crimp tool. Locate jaws at start of chamfer on crimp sleeve. Press sleeve firmly into coaxial shell and crimp.
- After assembled coaxial is inserted into connector, push support bushing into grommet until shoulder rests on tubular extension. Then pull sealing sleeve forward until it is snug on grommet.



Coaxial Cable Assembly Recommendations

LITTLE CAESAR Contact Assembly Data

For Codes F, S and T

1. Strip and trim cable as shown on page 60.
2. Solder inner conductor to coaxial contact with crimp ring over braid and rear insulator over inner conductor.
3. Insert cable into coaxial with shell under braid. Crimp ring with Cannon crimp tool CA58073.

For Codes G, H and R

1. Strip and trim cable as shown on page 60.
2. Solder inner connector to coaxial contact with crimp ring pushed back on cable.
3. Insert cable into coaxial and pull ring forward over braid. Crimp ring with Cannon crimp tool CA58073-0001 or CCT-408M. After crimping, crimp ring must not exceed .252 (6.40) diameter.

For Codes U

1. Strip and trim cable as shown on page 60.
2. Slide crimp ring over braid and jacket of cable.
3. Unbraid exposed portion of braid and fold braid wires backward over outside of crimp ring.
4. Insert prepared wire into right angle fitting of shell assembly. Conductor should be aligned in slot of the center contact. Crimp with Cannon tool CCT/C10.
5. Solder center conductor of cable to contact. Insert cap and solder in place.

For Codes AA

1. Slip ferrule over cable jacket. Trim outer jacket. Comb out braid as shown. Retrim braid.
2. Bend up combed out braid at right angles to cable. Slide ferrule up to bend and fold braid back against ferrule.
3. Slide rear insulator over dielectric as shown. Press insulator firmly against folded back braid and trim dielectric flush with insulator. Then cut inner conductor to length shown.
4. Place contact over conductor. Press contact and insulator firmly against braid and solder contact to conductor.
5. Push cable assembly into shell, pressing against rear of ferrule and crimp area shown with T. & B. #WT-400 Crimp Tool while making sure parts do not move out of place.

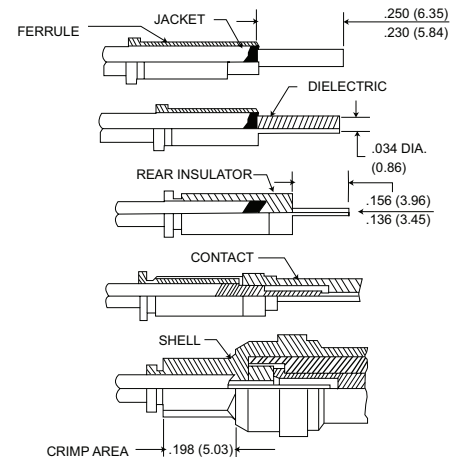

For Codes AC

1. Trim jacket to .680 (17.27)/.660 (16.76) dimension. Then slide ferrule over braid until it stops against jacket, and comb out exposed portion of braid.
2. Fold combed braid over ferrule as shown. Then trim dielectric to .070 (1.78)/.060 (1.52) dimension and slide rear insulator over dielectric until it presses against braid.
3. Press insulator against braid and trim inner conductor to .247 (6.27)/.237 (6.02) dimension. Then place contact over conductor and crimp with MS3191-3 (do not use MS3191-1). Press parts firmly against locator during crimping operation.
4. Place front insulator over contact. Push parts into coaxial shell. While holding parts firmly against stop shoulder in coaxial shell, place jaw of crimp tool at back end of shell and crimp. Use Buchanan crimp tool #612991 (.343 [8.71] across hex).

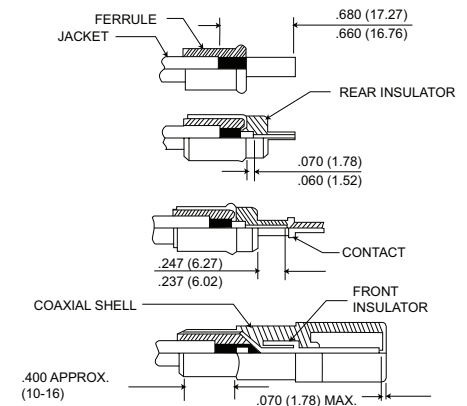

Coaxial Cable Assembly Recommendations (Continued)

For Code V

1. Trim cable to dimensions shown below.
 - A. Push ferrule under braid as far as it will go and press braid down tightly around ferrule.
 - B. Solder ends of braid to ferrule by applying a small amount of solder. Avoid excess solder as it would cause braid to swell up.
 - C. Remove any solder exceeding the .349 (8.86) max. diameter.
 - D. Check the .075 (1.90) max. dielectric extension, retrim if necessary.
3. A. Place rear insulator over dielectric and conductor into contact.
 - B. Solder contact to conductor through access hole.
 - C. Remove excess solder from outside of contact.
4. A. Place front insulator over contact.
 - B. Push parts into coaxial shell.
 - C. While holding parts firmly against stop shoulder in coaxial shell, place jaw of crimp tool at back end of shell and crimp, use Buchanan crimp tool #612991 [.343 (8.71) across hex].

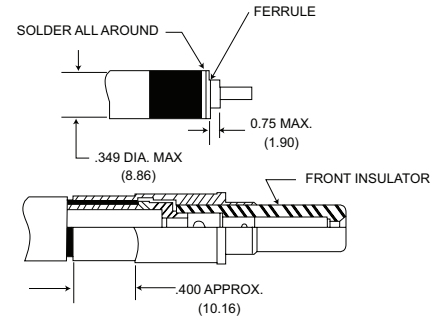

For Codes AB, AD, AE, AF and AG

- Step 1 - Trim cable as shown.
- Step 2 - Flare out ends of braid to permit entry of ferrule.
- Step 3 - Complete termination per instructions as shown below.
- a. Push ferrule under braid as far as it will go. Trim off braid extending beyond shoulder of ferrule, if necessary.
 - b. While holding ferrule in place pull crimp sleeve forward over braid until it is tight against shoulder on ferrule. Push firmly against face of ferrule to make sure it is up tight.
 - c. Trim dielectric to the .035 (0.89)/.030 (0.76) dimension.
 - d. Carefully push inner conductor through rear insulator.
 - e. While holding rear insulator firmly against ferrule, trim conductor to .156 (3.96)/.146 (3.71) dimension.
 - f. Place contact over conductor and solder.
 - g. Place front insulator over contact and then push assembly into coaxial shell.
 - h. Place parts in jaw of crimp tool. Locate jaws at start of chamfer on crimp sleeve. Press Sleeve firmly into coaxial shell and crimp. Use Daniels crimp tool HX4-210.

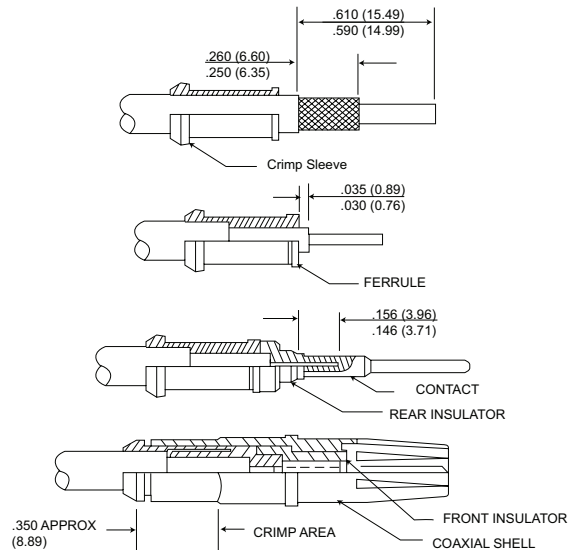

Cable Trim Dimensions

Code Letter	Inches			Millimeters		
	A	B	C	A	B	C
A	.420/.400	.432/.415	.330/.310	10.67/10.16	11.05/10.54	8.38/7.87
B, C, D & P	.420/.400	.460/.440	.330/.310	10.67/10.16	11.68/11.18	8.38/7.87
E	.420/.400	.480/.460	.330/.310	10.67/10.16	12.19/11.68	8.38/7.87
F	.785/.745	.275/.255	.228/.208	19.94/18.92	6.98/6.48	5.79/5.28
G	.490/.470	.275/.255	.156/.136	12.45/11.94	6.98/6.48	3.96/3.45
H & R	.581/.561	.345/.325	.156/.136	14.76/14.25	8.76/8.26	3.96/3.45
J	.326/.306	.250/.230	.088/.068	8.28/7.77	6.35/5.84	2.24/1.73
K	.410/.390	.290/.270	.088/.068	10.41/9.91	7.37/6.86	2.24/1.73
L	.385/.365	.244/.224	.074/.064	9.78/9.27	6.20/5.69	1.88/1.63
S	.678/.658	.275/.255	.156/.136	17.22/16.71	6.98/6.48	3.96/3.45
U	.940/.920	.760/.740	.080/.060	23.88/23.37	19.30/18.80	2.03/1.52
V	.550/.540	.415/.405	.250/.240	13.97/13.72	10.54/10.29	6.35/6.10
T	.598/.578	.300/.280	.228/.208	15.19/14.68	7.62/7.11	5.79/5.28
AA, AC	See page 60 for dimensions					
AB, AD, AE, AF, AG	See page 60 for dimensions					

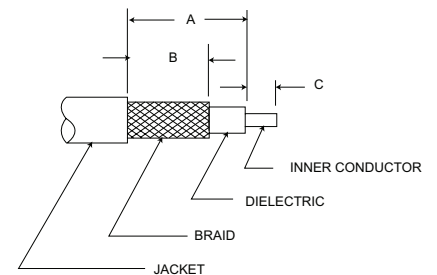

Dimensions shown in inch (mm)
 Specifications and dimensions subject to change

www.ittcannon.com











Modifications Codes

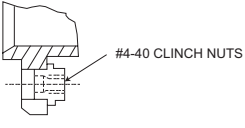

DPXA Modifications Codes

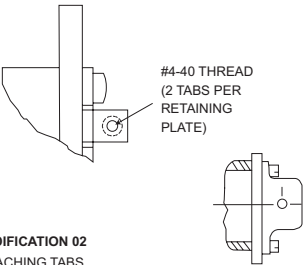
- 4. Mounting holes .120 (3.05) dia. c'sink 100° to .225 (5.72) dia.
- 5. 4-40 clinch nuts.
- 6. Removable insert retainer plate.
- 7. Mounting holes .120 (3.05) dia. c'sink 82° to .230 (5.84) dia.
- 12. Mounting holes .132 (3.35)/.125 (3.18).
- 16. A106 insert with separator.
- 17. With grommet and mounting holes .120 (3.05) dia. countersunk 100° to .225 (5.72) dia.
- 70. Standard mounting with (LIF) contacts.
- 77. Same as -7 except with low insertion force (LIF) contacts (for LIF contact data).

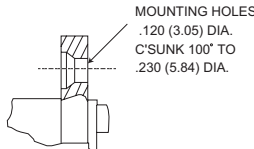
DPXB and DPX2/3/4 Modification Codes

Some of the modification numbers used in the DPX lines apply to all types and some are applicable for only certain types. The following chart gives the modification number, the description, and the shell type in which they may be used (-33 is for plug shells, -34 is for receptacle shells).

	Modification	Applicable Series	Definition
	- 00**	DPX2-33 and 34 DPX2-33A DPX2-33F and 34F DPX2-33M and 34M	Standard construction, mounting holes .120 (3.05) dia. and with tabs for junction shells.
	- 00	DPX2-34A	Standard construction - six floating eyelets and tabs for junction shells,
DESCRIBES STANDARD CONNECTOR HOUSING	- 00	DPX2-33B DPXB-33 DPX3-33 DPX4-33	Standard construction, mounting holes .120 (3.05) dia. countersunk 82° to .230 (5.84) dia. - no tabs. 
MODIFICATION 00	- 00	DPX2-34B DPXB-34 DPX3-34 DPX4-34	Standard construction, mounting holes 120 (3.05) dia. - no tabs. 
	- 01	DPX2-33 and 34 DPX2-33A DPX2-34A DPX2-33F and 34F DPX2-33M-34M	Standard construction and with standard junction shells.
MODIFICATION 01	- 01	DPX2-34B/33B DPXB-34	With four #4-40 clinch nuts in mounting holes.
	- 01	DPX3-34	With six #4-40 clinch nuts in mounting holes. 
	- 01	DPX4-34	With ten #440 clinch nuts in mounting holes. 
	- 02	DPX2-33 and 34 DPX2-33A DPX2-34A DPX2-33F and 34F DPX2-33M and 34M	Standard construction and with 90° junction shells.
MODIFICATION 02 ATTACHING TABS	- 02	DPX2-33B and 34B DPXB-33 and 34 DPX3-33 and 34 DPX4-33 and 34	Standard construction and with tabs for attaching junction shells. 
ALTERNATE STYLE	- 02	DPXBME-33 and 34 DPX2ME-33 and 34 DPX3ME-33 and 34 DPX4ME-33 and 34	Standard construction and with tabs for attaching junction shells. 
	- 03	DPX2-33 and 34 DPX2-33A DPX2-33F and 34F DPX2-33M and 34M DPXB-33 and 34 DPX3-33 and 34 DPX4-33 and 34	Mounting holes .120 (3.05) dia. countersunk 100° to .230(5.84) dia. 
MODIFICATION 03			

 Applicable for all MA, ME, NA & NE Series Connectors.
 Applicable to NE Series also.

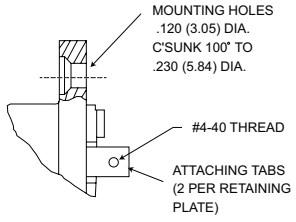
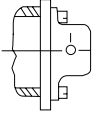
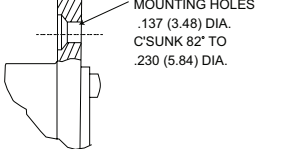
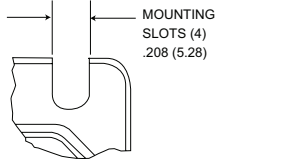
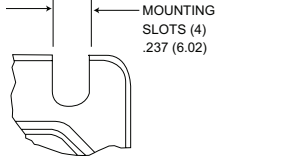
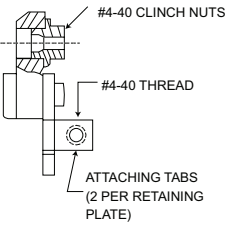
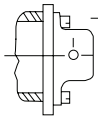
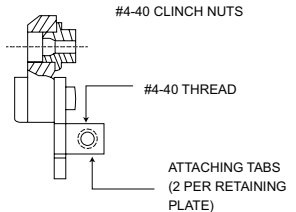
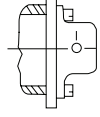

Modifications Codes

	Modification	Applicable Series	Definition
 <p>MOUNTING HOLES .120 (3.05) DIA. C'SUNK 100° TO .230 (5.84) DIA.</p> <p>#4-40 THREAD</p> <p>ATTACHING TABS (2 PER RETAINING PLATE)</p> <p>MODIFICATION 04</p>	- 04**	DPX2-33B DPXB-33 DPX3-33 DPX4-33	.120 (3.05) dia. mounting notes countersunk 100° to .230 (5.84) dia. and tabs for attaching junction shells.
 <p>ALTERNATE STYLE</p>			
 <p>MOUNTING HOLES .137 (3.48) DIA. C'SUNK 82° TO .230 (5.84) DIA.</p> <p>MODIFICATION 08</p>	- 08	DPX2-33 and 34 DPX2-33F and 34F	Mounting holes .137 (3.48) dia. countersunk 82° to .230 (5.84) dia.
 <p>MOUNTING SLOTS (4) .208 (5.28)</p> <p>MODIFICATION 12</p>	- 12	DPX2-34B DPXB-34	With mounting slots .208 (5.28) wide.
 <p>MOUNTING SLOTS (4) .237 (6.02)</p> <p>MODIFICATION 13</p>	- 13	DPX2-34B DPXB-34	With mounting slots .237 (6.02) wide.
<p>(SEE PAGE 62 FOR JUNCTION SHELL CONFIGURATIONS)</p>	- 14	DPX2-33B DPXB-33 DPX2-34B DPXB-34 DPX3-33 DPX3-34	With straight junction shelf. (Not available on DPX4)
 <p>#4-40 CLINCH NUTS</p> <p>#4-40 THREAD</p> <p>ATTACHING TABS (2 PER RETAINING PLATE)</p> <p>MODIFICATION 17</p>	- 17	DPX2-33B DPXB-33 DPX2-34B DPXB-34	With four #4-40 clinch nuts in mounting holes and tabs for attaching junction shells.
 <p>ALTERNATE STYLE</p>	- 17	DPX3-34	With six #4-40 clinch nuts in mounting holes and tabs for attaching junction shells.
	- 17	DPX4-34	With ten #4-40 clinch nuts in mounting holes and tabs for attaching junction shells.
 <p>#4-40 CLINCH NUTS</p> <p>#4-40 THREAD</p> <p>ATTACHING TABS (2 PER RETAINING PLATE)</p> <p>MODIFICATION 18</p>	- 18	DPX2-33B DPXB-33 DPX2-34B DPXB-34 DPX3-34	With six #4-40 clinch nuts in mounting holes and tabs for attaching junction shells.
 <p>ALTERNATE STYLE</p>			









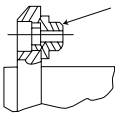
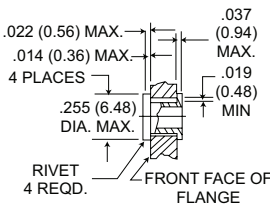

⚠ Applicable for all MA, ME, NA & NE Series Connectors.

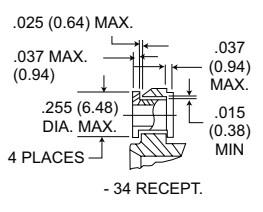
Dimensions shown in inch (mm)
Specifications and dimensions subject to change

www.ittcannon.com



Modifications Codes

	Modification	Applicable Series	Definition
 <p>#4-40 CLINCH NUTS</p> <p>MODIFICATION 19</p>	- 19**	DPX2-33B DPXB-33 DPX2-34B DPXB-34 DPX3-33 DPX3-34 (Same as Code -01)	With six #4-40 clinch nuts in mounting holes. Do not assign - use -01 code
<p>MODIFICATION 20</p>	- 20	DPX2-33A DPX2-34A	Standard construction without tabs on insert retaining plate.
<p>SUPERSEDED BY 01 MOD.</p> <p>MODIFICATION 22</p>	- 22	DPX2-33 and 34 DPX2-33A DPX2-33B DPXB-33 DPX2-33M and 34M DPX3-33 DPXBME, DPX2ME, DPX3ME, DPX4ME - 33 only DPX2-33F and 34F	With eight #4-40 clinch nuts in mounting holes. Same as 01. 01 Recommended
 <p>.022 (0.56) MAX. .014 (0.36) MAX. .037 (0.94) MAX. .019 (0.48) MIN. .255 (6.48) DIA. MAX. 4 PLACES RIVET 4 REQD. FRONT FACE OF FLANGE</p> <p>- 33 PLUG</p> <p>MODIFICATION 23</p>	- 23	DPX2-33 and 34 DPX2-33A DPX2-33B DPXB-33 DPX2-34B DPXB-34 DPX3-33 and 34 DPX4-33 and 34 DPX2-33F and 34F	With floating eyelets. 
 <p>MOUNTING HOLES(4), .156(3.96) DIA.</p> <p>MODIFICATION 25</p>	- 24	DPX2-34A DPX2-33B	With six mounting holes .208 (5.28) dia. (Floating eyelets omitted)
	- 25	DPX2-34B DPXB-34	With four mounting holes .157 (3.99)/.155 (3.94) dia. (Clinch nuts omitted) 
 <p>MOUNTING HOLES(4), .120 (3.05) DIA., C'SUNK 82° TO .230 (5.84) DIA.</p> <p>MODIFICATION 26</p>	- 26	DPX2-34B DPXB-34 DPX3-34	Mounting holes .120 (3.05) dia. countersunk 82° to .230 (5.84) dia. and has tabs for attaching junction shells. 
	- 29	DPX2-34A	With interfacial seal (if pins) without junction shell tabs and military gold plating on the contact.
	- 29	DPXBME-34P & 33S DPX2ME-34P & 33S DPX3ME-34P & 33S DPX4ME-34P & 33S	Standard except less grommet*  * On the A106S layout the grommet is replaced by the separator.
	- 30	DPXBME-34P DPX2ME-34P DPX3ME-34P DPX4ME-34P	Standard except less grommet and with tabs for attaching junction shells. (-34 pin only) 
	- 31	DPXBME-34P DPX2ME-34P DPX3ME-34P DPX4ME-34P	Standard except less grommet and with floating bushings. (Slatted shells). 
	- 33	DPXBME-34P DPX2ME-34P DPX3ME-34P DPX4ME-34P	Standard except less grommet and with clinch nuts in mounting holes. 
	- 37	DPXBME-34P DPX2ME-34P DPX3ME-34P DPX4ME-34P	Standard less grommet and with clinch nuts in mounting holes and with tabs for attaching junction shells. 

 Applicable for all MA, ME, NA and NE Series Connectors.





**Indicates polarizing position. (See page 72)

Dimensions shown in inch (mm)
Specifications and dimensions subject to change

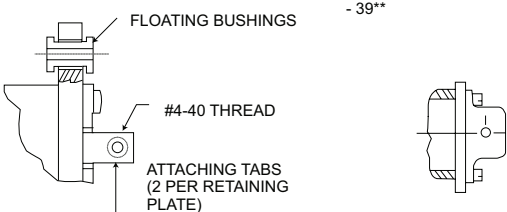
Modifications Codes

Modification	Applicable Series	Definition
 <p>MODIFICATION 39</p> <p>ALTERNATE STYLE</p>	<p>- 39**</p> <p>DPXB-33 & 34 DPX2-33B DPX2-34B DPX3-33 & 34 DPX4-33 & 34</p>	<p>With floating eyelets & tabs for attaching junction shells.</p>
<p>The -7*** and 8*** Modification Codes are reserved for connectors which have Low Insertion Force (LIF) Contacts. The LIF design is not applicable to thermocouple contacts, coaxial contacts and contacts larger than size 8 and Standard size 20</p>		
- 70**	All DPX series with LITTLE CAESAR retention	Same as -00 with addition of LIF contacts See Contact Section Page 54
- 71	All DPX series with LITTLE CAESAR retention	Same as -31 with addition of LIF contacts See Contact Section Page 54
- 72	All DPX series with LITTLE CAESAR retention	Same as -01 with addition of LIF contacts See Contact Section Page 54
- 73	All DPX series with LITTLE CAESAR retention	Same as -23 with addition of LIF contacts See Contact Section Page 54
- 74	All DPX series with LITTLE CAESAR retention	Same as -33 with addition of LIF contacts See Contact Section Page 54
- 75	All DPX series with LITTLE CAESAR retention	Same as -02 with addition of LIF contacts See Contact Section Page 54
- 76	All DPX as listed for code -22	Same as -22 with addition of LIF contacts
- 77	All DPXB series	Mounting holes .120 (3.05) dia. countersunk 82° to .230 (5.84) dia. and has LIF contacts.
- 78		
- 79	All DPX series with LITTLE CAESAR retention	Same as -29 with addition of LIF contacts

 Applicable for all MA, ME, NA and NE Series Connectors.

 Applicable for NE Series Also.

**Indicates polarizing position. (See page 72)

Polarization

Two Post Type

Face View of Engaging End

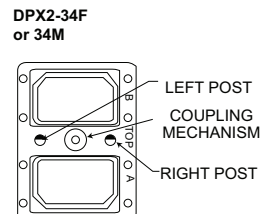
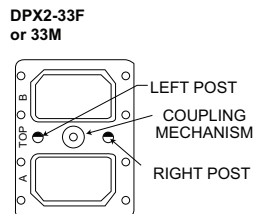

Three Post Type

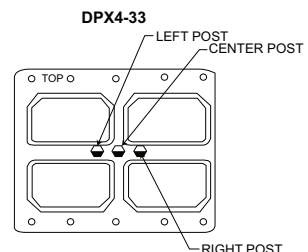
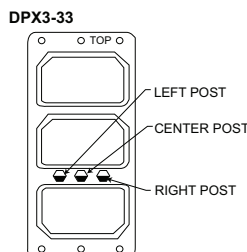
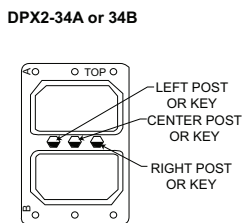
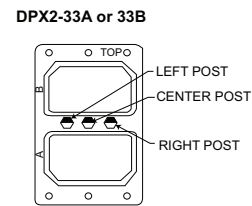
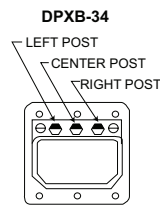
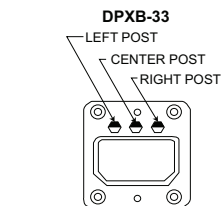

Dimensions shown in inch (mm)
Specifications and dimensions subject to change

www.ittcannon.com



Polarization

Positions

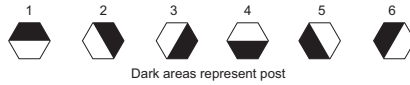

Two Post Type

33 PLUG MALE SHELL						34 RECEPTACLE FEMALE SHELL					
Position	Left Post	Right Post	Position	Left Post	Right Post	Position	Left Post	Right Post	Position	Left Post	Right Post
01	4	4	09	3	3	01	1	1	09	2	2
02	5	4	10	4	2	02	1	6	10	3	1
03	6	4	11	2	2	03	1	5	11	3	3
04	2	4	12	3	2	04	1	3	12	3	2
05	3	4	13	2	1	05	1	2	13	4	3
06	4	3	14	3	1	06	2	1	14	4	2
07	5	3	15	2	6	07	2	6	15	5	3
08	2	3				08	2	3			

Three Post Type

PLUG SHELL					RECEPTACLE SHELL										
Position	Left Post	Center Post	Right Post	Position	Left Post	Center Post	Right Post	Position	Left Post	Center Post	Right Post	Position	Left Post	Center Post	Right Post
01	1	1	1	51	3	2	5	01	4	4	4	51	6	3	2
02	2	1	1	52	4	2	5	02	4	4	3	52	6	3	1
03	3	1	1	53	5	2	5	03	4	4	2	53	6	3	6
04	4	1	1	54	6	2	5	04	4	4	1	54	6	3	5
05	5	1	1	55	1	2	4	05	4	4	6	55	1	3	4
06	6	1	1	56	2	2	4	06	4	4	5	56	1	3	3
07	1	1	6	57	3	2	4	07	5	4	4	57	1	3	2
08	2	1	6	58	4	2	4	08	5	4	3	58	1	3	1
09	3	1	6	59	5	2	4	09	5	4	2	59	1	3	6
10	4	1	6	60	6	2	4	10	5	4	1	60	1	3	5
11	5	1	6	61	1	2	3	11	5	4	6	61	2	3	4
12	6	1	6	62	2	2	3	12	5	4	5	62	2	3	3
13	1	1	5	63	3	2	3	13	6	4	4	63	2	3	2
14	2	1	5	64	4	2	3	14	6	4	3	64	2	3	1
15	3	1	5	65	5	2	3	15	6	4	2	65	2	3	6
16	4	1	5	66	6	2	3	16	6	4	1	66	2	3	5
17	5	1	5	67	1	2	2	17	6	4	6	67	3	3	4
18	6	1	5	68	2	2	2	18	6	4	5	68	3	3	3
19	1	1	4	69	3	2	2	19	1	4	4	69	3	3	2
20	2	1	4	70	4	2	2	20	1	4	3	70	3	3	1
21	3	1	4	71	5	2	2	21	1	4	2	71	3	3	6
22	4	1	4	72	6	2	2	22	1	4	1	72	3	3	5
23	5	1	4	73	1	3	1	23	1	4	6	73	4	2	4
24	6	1	4	74	2	3	1	24	1	4	5	74	4	2	3
25	1	1	3	75	3	3	1	25	2	4	4	75	4	2	2
26	2	1	3	76	4	3	1	26	2	4	3	76	4	2	1
27	3	1	3	77	5	3	1	27	2	4	2	77	4	2	6
28	4	1	3	78	6	3	1	28	2	4	1	78	4	2	5
29	5	1	3	79	1	3	6	29	2	4	6	79	5	2	4
30	6	1	3	80	2	3	6	30	2	4	5	80	5	2	3
31	1	1	2	81	3	3	6	31	3	4	4	81	5	2	2
32	2	1	2	82	4	3	6	32	3	4	3	82	5	2	1
33	3	1	2	83	5	3	6	33	3	4	2	83	5	2	6
34	4	1	2	84	6	3	6	34	3	4	1	84	5	2	5
35	5	1	2	85	1	3	5	35	3	4	6	85	6	2	4
36	6	1	2	86	2	3	5	36	3	4	5	86	6	2	3
37	1	2	1	87	3	3	5	37	4	3	4	87	6	2	2
38	2	2	1	88	4	3	5	38	4	3	3	88	6	2	1
39	3	2	1	89	5	3	5	39	4	3	2	89	6	2	6
40	4	2	1	90	6	3	5	40	4	3	1	90	6	2	5
41	5	2	1	91	1	3	4	41	4	3	6	91	1	2	4
42	6	2	1	92	2	3	4	42	4	3	5	92	1	2	3
43	1	2	6	93	3	3	4	43	5	3	4	93	1	2	2
44	2	2	6	94	4	3	4	44	5	3	3	94	1	2	1
45	3	2	6	95	5	3	4	45	5	3	2	95	1	2	6
46	4	2	6	96	6	3	4	46	5	3	1	96	1	2	5
47	5	2	6	97	1	3	3	47	5	3	6	97	2	2	4
48	6	2	6	98	2	3	3	48	5	3	5	98	2	2	3
49	1	2	5	99	3	3	3	49	6	3	4	99	2	2	2
50	2	2	5					50	6	3	3				

The last two digits in the DPX nomenclature (ex: DPXB-8-33B-0014) refer to the polarizing post position. When the last two digits are omitted it means the polarizing posts will not be assembled and position number is not stamped on the connector. This allows the customer to position the posts themselves and then stamp the appropriate number on the shell. If the last two digits are made 00 it means the polarizing posts are deleted.



Dimensions shown in inch (mm)
Specifications and dimensions subject to change

www.ittcannon.com

Panel Cutouts

DPXA

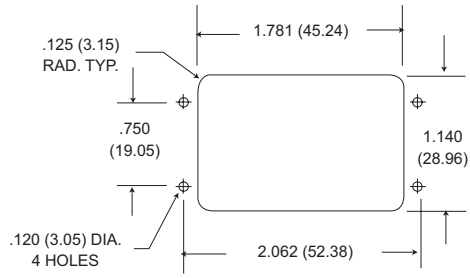

NOTE - WHEN USING THE -2301 FLOATING EYELET MODIFICATION, ADD .050 (1.27) TO THE CUTOUT SIZE TO ALLOW FOR FLOAT (EXCEPTION -34A)

DPXB

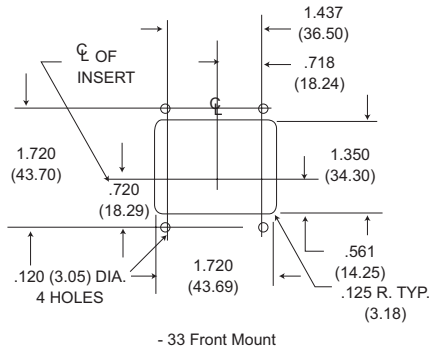

- 33 Front Mount

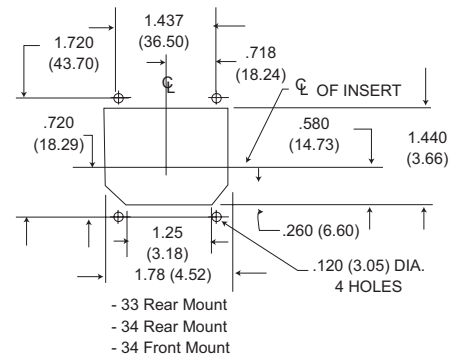

- 33 Rear Mount
- 34 Rear Mount
- 34 Front Mount

Panel Cutouts

DPX2

All tolerances are ± .015 (0.38) unless otherwise noted.

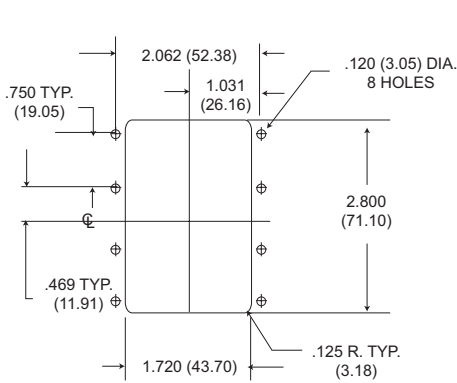

- 33 FRONT MOUNT

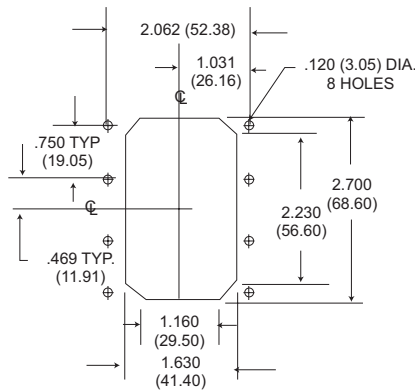

- 33 REAR MOUNT

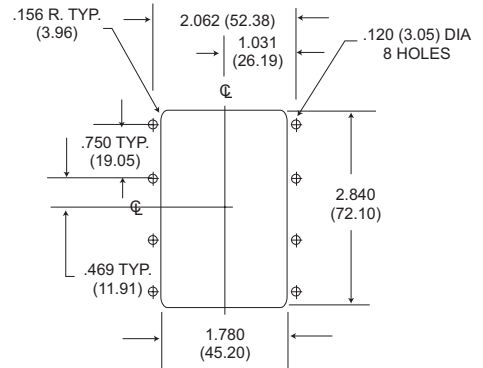

- 34 FRONT OR REAR MOUNT

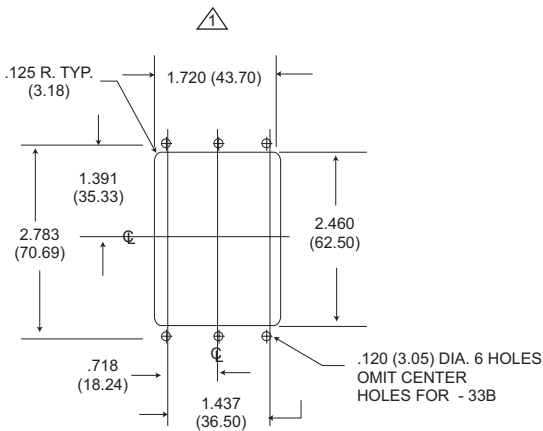

- 33A & -33B FRONT MOUNT

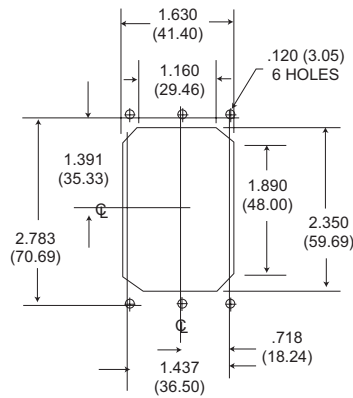

- 33A REAR MOUNT

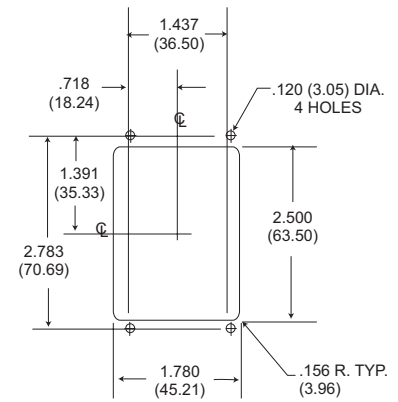

- 34B FRONT MOUNT

For - 23 float mtg. mod. 1.78 (45.21).

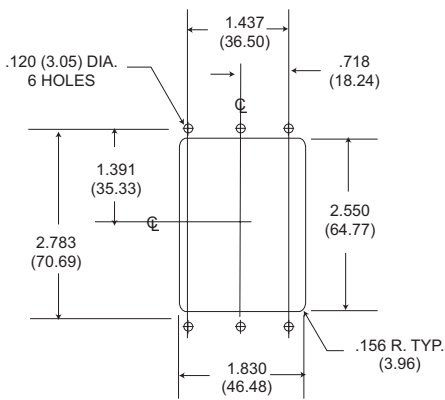

- 34A REAR MOUNT (-34A FRONT MOUNT CONSULT FACTORY)

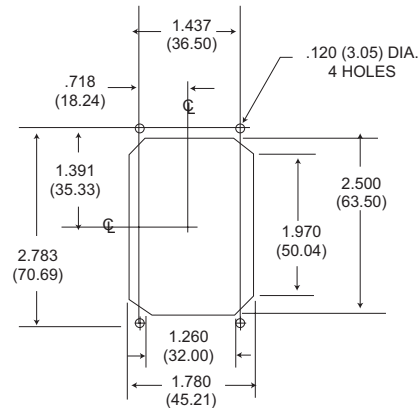

- 33B REAR MOUNT - 33B REAR MOUNT



Dimensions shown in inch (mm)
Specifications and dimensions subject to change

www.ittcannon.com

Panel Cutouts

DPX3

All tolerances are $\pm .015$ (0.38) unless otherwise noted.

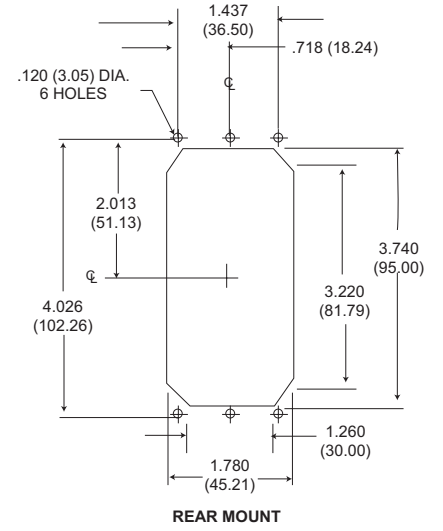
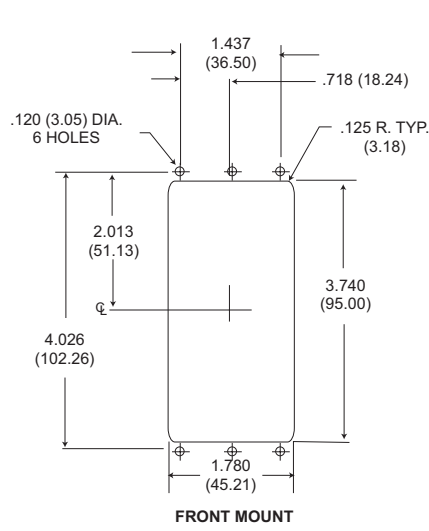

DPX4

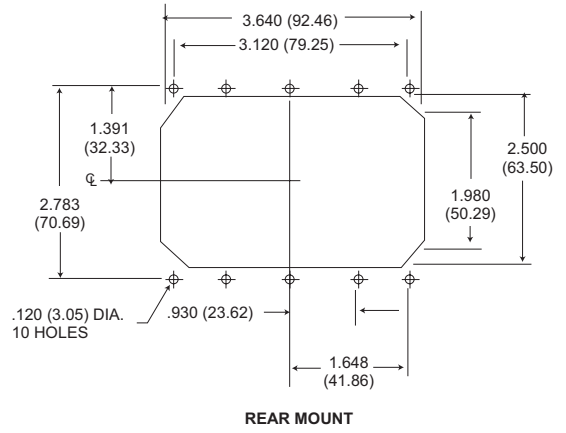
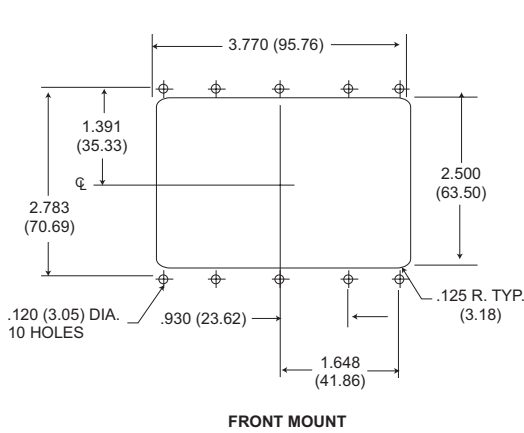

Dimensions shown in inch (mm)
 Specifications and dimensions subject to change

www.ittcannon.com



Sealing Plugs - DPX*ME (for environmental requirements)

Material: Teflon
(All others thermoplastic)

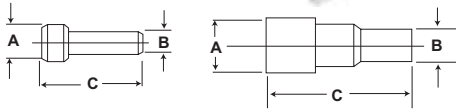

Part Number	Contact Size	Color	A	B	C
225-1013-000	22	Black	.063 (1.6)	.040 (1.0)	.469 (11.9)
225-0070-000	20	Red	.085 (2.2)	.065 (1.6)	.469 (11.9)
225-0071-000	16	Blue	.115 (2.9)	.075 (1.9)	.469 (11.9)
225-0072-000	12	Yellow	.171 (4.3)	.121 (3.1)	.564 (14.3)
225-0090-000	#5 and #9 Coax	White	.365 (9.3)	.287 (7.3)	.835 (21.2)

Filler Plugs - DPX*

Material: Teflon
(All others thermoplastic)

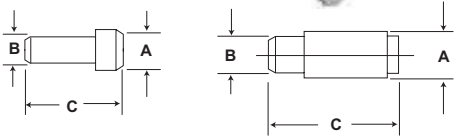

Part Number	Contact Size	Color	A	B	C
225-0094-000	22	Black	.069 (1.7)	.051 (1.3)	.420 (10.7)
225-0095-000	20	Red	.083 (2.1)	.069 (1.7)	.350 (8.9)
225-0096-000	16	Blue	.131 (3.3)	.108 (2.7)	.320 (8.1)
225-0097-000	12	Yellow	.187 (4.7)	.156 (4.0)	.320 (8.1)
225-0098-000	#5 Coax (Pin)	White	.275 (7.0)	.251 (6.4)	.450 (11.4)
225-0099-000	#5 and #9 Coax (Socket)	White	.275 (7.0)	.251 (6.4)	1.061 (26.9)



Junction Shells

90° Angle

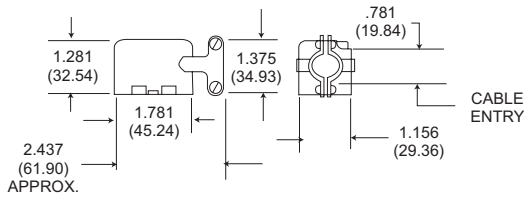

Style	Part Number
(Right) DPXA	20745-22
(Left) DPXA	20745-23
(Right) DPX2	20745-10
(Left) DPX2	20745-11

(DPXA ONLY)
DIECAST STRAIGHT JUNCTION SHELL

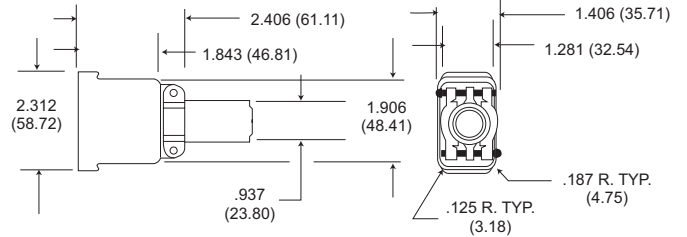

Style	Part Number
DPXA	22017

90° ANGLE DPX2
JUNCTION SHELL (SIDE OUTLET)

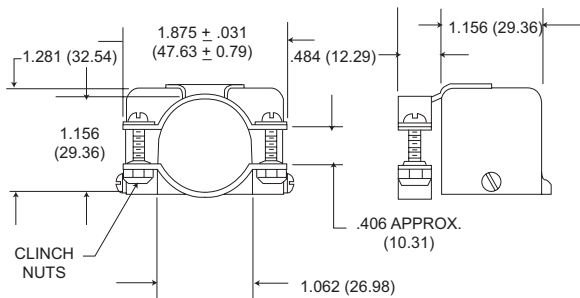

Style	Part Number
DPX2	20745-12

(DPXA ONLY)
DIECAST STRAIGHT JUNCTION SHELL

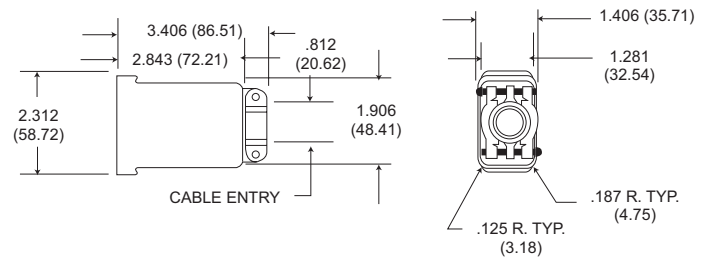

Style	Part Number
DPXA	22017-2

(DPXA ONLY)
DIECAST 90° ANGLE JUNCTION SHELL

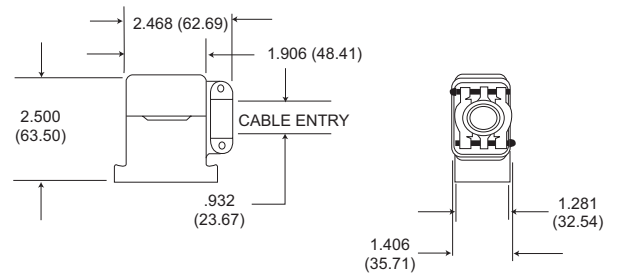

Style	Part Number
DPXA	22017-1

Diecast junction shells may be used on DPXA connectors. They have 4-40 NC-2B tapped mounting holes for attaching to the shell mounting hardware.

STRAIGHT JUNCTION SHELL

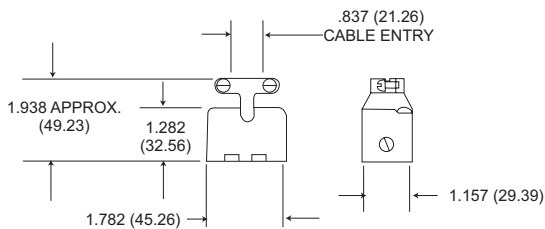

Style	Part Number
DPXA	20745-21
DPX2	20745-8

* DPX2 Junction Shells are also used on DPXB connectors.

Dust Caps



34

Conductive

DPXB-60-1 for 34 Shell
Conductive Dust Caps
025-0767-001
Protect Against
Static Electricity



33

Conductive

DPXA-59 for 33 Shells
025-0749-001

Dimensions shown in inch (mm)
Specifications and dimensions subject to change

www.ittcannon.com



Coaxial Cable Reference Guide

For BKA* DPX Series (Crimp, & Solder)
 Reference MIL-C-17D & DPX NE/NA MIL-C-81659 Series

RG/U Type	Inner Conductor	Dielectric Material	DOD (Inch)	Jacket Material	O.D (Inch)	Weight (lbs/ft)	Max Oper. Temp, Range (C)	Max Oper. Voltage (Volts RMS)	Suggested Alt Cable	Code Crimp Type Coax	Code Solder Type Coax	DPX NE/NA Military	BKA* ARINC Type Coax
7	0.0359 "	Air-space PE	0.250	PVC	0.370	0.080	-40 + 80	1,000	Use RG63B	—	I	—	—
9	0.0855"	PE	0.280	PVC	0.420	0.140	-40 + 80	4,000	Use RG214	—	R,AC	—	Size 1(71W1)
55	0.0320 "	PE	0.116	PE	0.206 Max.	0.032	-55 + 80	1,900	Use RG55B	S	C, J	—	Size 1(71W1)
58	0.0320"BC	PE	0.116	PVC	0.195	0.029	-40 + 80	1,900	Use RG58B	D,P,G JAC,AD	C, J, Z AB	Size 5/9 Seal 1	Size 1(71W1) Size 5
59	0.0253 "	PE	0.146	PVC	0.242	0.032	-40 + 80	2,300	Use RG59B	A,F,T	D	—	—
59B	0.0230"	PE	0.146	PVC	0.242	0.032	-40 + 80	2,300	Use up to 1000 MHz	—	—	—	—
62	0.0253"	Air-space PE	0.146	PVC	0.242	0.038	-40 + 80	750	Use RG62A	A,F,T	E	—	—
62A	0.0253"	Air-space PE	0.146	PVC	0.242	0.038	-40 + 80	750	—	—	—	—	—
71	0.0253"	Air-space PE	0.146	PVC	0.250 Max.	0.046	-40 + 80	750	Use RG71B	—	E	—	—
115	0.0840"	PTFE	0.250	FG Braid	0.375	0.148	-55 + 250	5,000	Use RG115A	V	—	—	Size 1(71W1)
142	0.0359"	PTFE	0.116	FG Braid	0.206 Max.	0.047	-55 + 250	1,900	Use RG142A	S,AE	—	Size 5/9 Seal 1	Size 1(71W1) Size 1(71W1A)
142B	0.0390"	PTFE	0.116	FEP	0.195	0.050	-55 + 200	1,900	—	—	—	—	Size 1(71W1A) Size 5
174	0.0189"	PE	0.060	PVC	0.100	0.008	-40 + 80	1,500	—	D,H,U, AF	—	Size 5/9 Seal 2	Size 5 Size 12
178	0.0120"	PTFE	0.036	KEL-F	0.079 Max.	0.0054	-40 + 150	1,000	Use RG178B	ER,K,AG, L,M,AF	—	Size 5/9 Seal 1	Size 5
179	0.0120 "	PTFE	0.057	KEL-F	0.094 Max.	0.010	-55 + 150	1,200	Use RG179B	D,H,U, AF	—	Size 5/9 Seal 1 Seal 2	Size 5
179B	0.0120"	PTFE	0.063	FEP	0.100	0.010	-55 + 200	1,200	—	—	—	—	Size 5
180	0.0120"	PTFE	0.103	KEL-F	0.141 Max.	0.019	-40 + 150	1,500	Use RG180B	CAB	B	Size 5/9 Seal 1	Size 5
180B	0.0120"	PTFE	0.102	FEP	0.145 Max.	0.019	-55 + 200	1,500	—	AB	—	—	Size 5
187	0.0120"	PTFE	0.060	PTFE	0.110 Max.	0.010	-55 + 250	1,200	Use RG179B	D,H,U, AF	A,K	—	Size 5
188	0.0201"	PTFE	0.060	PTFE	0.110 Max.	0.011	-55 + 250	1,200	Use RG316	D,A,U AF	A,K	—	—
195	0.0120"	PTFE	0.102	PTFE	0.155 Max.	0.020	-55 + 250	1,500	Use RG180B	CAB	B	—	Size 5
196	0.0120"	PTFE	0.034	PTFE	0.080 Max.	0.006	-55 + 250	1,000	Use RG178B	E,R,K, L,AA,AG	AA	Size 5/9 Seal 1	Size 5
214	0.0888"	PE	0.285	PVC	0.425	0.126	-40 + 80	5,000	—	—	R,AC	—	Size 1(71W1) Size 1(71W1A)
223	0.035 "	pE	0.116	PVC	0.216 Max.	0.034	-40 + 80	1,900	—	—	C,J	—	—
225	0.0936"	PTFE	0.285	FG Braid	0.430	0.180	-55 + 250	5,000	—	—	—	Size 5/9 Seal 2	Size 1(71W1)
316	0.0201	PTFE	0.060	FEP	0.102	0.012	-55 + 200	1,200	Use RG188A	—	—	Size 5/9 Seal 2	—
393	0.0936"	PTFE	0.285	FEP	0.390	0.165	-55 + 200	5,000	Use RG225	—	—	—	Size 1(71W1A)
400	0.0385"	PTFE	0.116	FEP	0.195	0.050	-55 + 200	1,900	—	—	—	—	Size 1(71W1)
402	0.0360"	PTFE	0.119	None	0.141	0.032	-55 + 200	2,500	Use RG142B	—	—	—	Size 1(71W1) Size 1(71W1A)

NOTE: This table is shown for reference only. ITT Cannon recommends that the above information be used as a guideline and may be subject to variation between various cable manufacturers. For specific information concerning the actual physical characteristics of a specific cable, contact the manufacturer.



Dimensions shown in inch (mm)
 Specifications and dimensions subject to change

www.ittcannon.com

HIGH-PERFORMANCE MIL-C-83733 QUALIFIED Temperature Ranges of - 65 C to +200 C Environment - Resistant

The Cannon DPK series are high performance environment- resistant, rectangular connectors qualified to MIL-C-83733 (USAF). They feature crimp snap-in contacts in the dependable LITTLE CAESAR® rear release contact retention assembly. This field-proven assembly permits contacts to be inserted and extracted at the rear of the connector. Contacts are qualified to military specifications and are crimped with MIL-C-22520 crimp tools, using standard locators.

The versatile DPK Connector is suitable for many applications, particularly where environment or thermal protection is mandatory and high reliability is a design requirement.

These high performance connectors are available in two shell sizes with a variety of mounting configurations. There are 13 contact arrangements available accommodating from 18 to 185 standard contacts. The standard contacts are available in sizes 12, 16, 20 and 22D. Shells are a die-cast aluminum alloy with electroless nickel finish. Insulators are a high grade, glass reinforced, resin conforming to MIL-M-14 which meets or exceeds the requirements of MIL-C-83733. Silicone rubber is used for wire sealing grommets, interfacial and peripheral seals.



How To Order

RoHS version

R - RoHS compatible

SHELL SIZE

A - Small shell
B - Large shell

CONTACT MODIFICATION

G-MIL-C-38999 contacts. Size 22D for DPKA-131 and DPKB-185 contact arrangements only.
W-MIL-C-38999 type contacts. Size 22D wrap posts for DPKA-131 and DPKB-185 layouts. .025 (0.63) square posts for .340(8.64); extension from grommet face.

CONTACT ARRANGEMENT

Shell Size A-18, 32, 51 and 131 (MIL-STD-1531).
Shell Size B-48, 64, 78, 101 59W7, 71, 71C15, 161 and 185 (MIL-STD-1532).

CONTACT TYPE

P-Pin (Receptacle Connectors)
S-Socket (Plug Connectors)

POLARIZATION

Six-position shell polarization accomplished with Polarizing pins mounted on each end of shell flange. Available on mounting style A only.

MOUNTING STYLES

- A - Two mounting holes .197(5.00) diameter (for either nuts or jackscrews ordered separately) and two polarizing posts. (Replaces Mounting Style B.)
- C - Four MS24700-2 bushings, included for the receptacle (M83733/5).
- F - Four (4) clinch nuts jNo. 6-32 thread M83733/6.

Dimensions shown in inch (mm)
Specifications and dimensions subject to change

www.ittcannon.com

MIL-C-83733 (USAF) Nomenclature

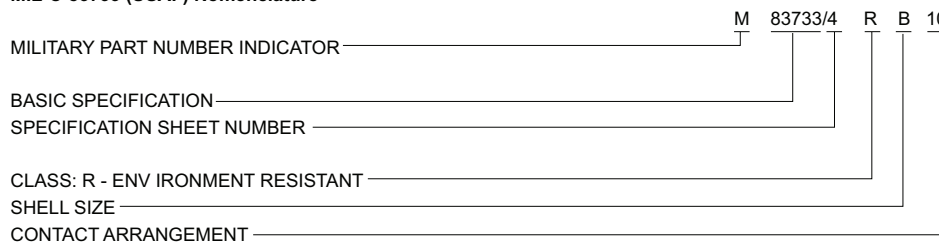

ITT Nomenclature

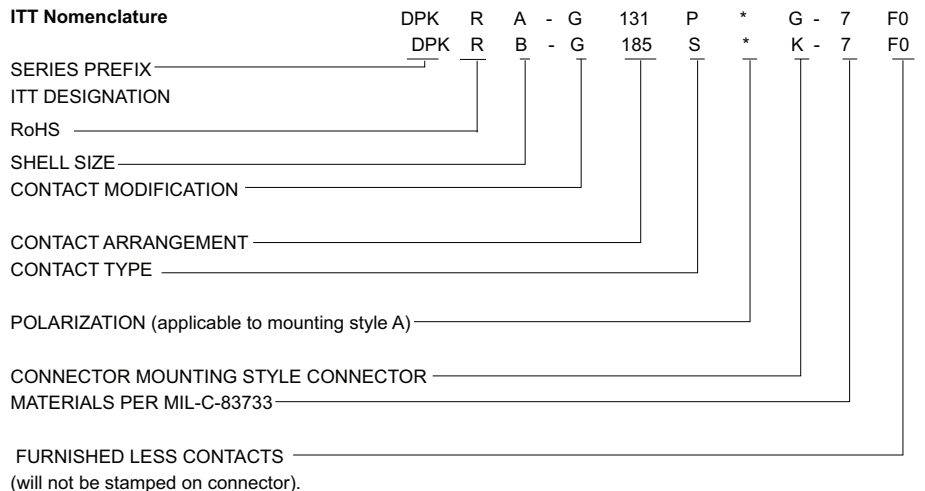

- G - Four .281(7.14) diameter holes (for MS24700-2 bushings or 231-0019-000 spring mounts) (M83733/1).
- H- Two mounting hole flange. Two (231-0019-000) spring mounts on the plug and two MS24700-2 bushing mounts on the receptacle (M83733/10/12).
- K - Four captivated, non-rotating spring mounts on the plug (M83733/4).
- M- Two mounting hole flange. Two mounting holes .281(7.14) diameter (for MS24700-2 bushings or 231-0019-000 spring mounts) (M83733/9).

- X - Two guide pins with two (231-0019-000) spring mounts on the plug and two guide sockets with two .197(5.00) diameter holes on the receptacle (M83733/2; /3)
- Y - Two guide sockets with two (231-0019-000) spring mounts on the plug and two guide pins with .197(5.00) diameter holes on the receptacle (M83733/7; /8).
- Z - Two staggered clinch nuts on the receptacle (No. 6-32 thread) (MB3733/11).

MATERIAL MOOIRCATION
- 7 standard product line, environment resistant per MIL-C-83733(USAF). QPL M83733



Performance and Material Specifications

MATERIALS

Shell	Diecast aluminum alloy A-380 per QQ-A-591
Insulator	Thermosetting Plastic/Thermoplastic
Contacts	Copper alloy per QQ-C-533
Grommets and Seals	Silicone base elastomer
Mounting hardware	Stainless stell/Alloy steel

FINISHES

Shell	Electroless nickel plate per MIL-C-26074, Class 3
Contacts	Gold over suitable underplate per MIL-C-39029
Hardware	Passivate/Cadmium plate

MECHANICAL FEATURES

Shell Sizes	A (DPKA); B (DPKB)
Coupling	Friction, spring mount or jackscrew-coupling nut
Contact Arrangements	A-18,32,51,G131 B-48,64,78,101,59W7,71,71C15,161 G185
Contact Termination	Crimp

ELECTRICAL

Contact Sizes	Wire Accommodation (AWG)	Sealing Range Wire Diameter	
		Min.	Max.
22D	22,24,26	.030(0.76)	.060(1.52)
20	20,22,24	.040(1.02)	.083(2.11)
16	16,18	.063(1.60)	.103(2.62)
12	12,14	.081(2.06)	.158(4.01)
12	RG-179/U	.081(2.06)	.158(4.01)

Max. current carrying capacity of contacts

Contact Size:	#12	#16	#20	#22
Amperage:	23	13	7.5	5.0

Test Voltages (AC-RMS)

Altitude (feet)	Equivalent Pressure (Torr)	Service Ratings (M&I)				Unmated 161 Arrangement
		Mated		Unmated		
		M	I	M	I	
Sea level	-	1300	1800	1300	1800	1000
50,000	87.5	800	1000	550	600	350
70,000	35.5	800	1000	350	400	250
110,000	5.74	800	1000	200	200	150

Cross Reference From Military to Cannon Part Numbers

MIL-SPEC P/N	ITTC P/N	MIL-SPEC P/N	ITTC P/N	MIL-SPEC P/N	ITTC P/N	MIL-SPEC P/N	ITTC P/N
M83733/1RA018	DPKA-18PG-7	M83733/4RA018	DPKA-18SK-7	M83733/7RA018	DPKA-18SY-7	M83733/10RA018	DPKA-18PH-7
M83733/1RA032	DPKA-32PG-7	M83733/4RA032	DPKA-32SK-7	M83733/7RA032	DPKA-32SY-7	M83733/10RA032	DPKA-32PH-7
M83733/1RA051	DPKA-51PG-7	M83733/4RA051	DPKA-51SK-7	M83733/7RA051	DPKA-51SY-7	M83733/10RA051	DPKA-51PH-7
M83733/1RA131	DPKA-G131PG-7	M83733/4RA131	DPKA-G131 SK-7	M83733/7RA131	DPKA-G131SY-7	M83733/10RB048	DPKB-48PH-7
M83733/1RB048	DPKB-48PG-7	M83733/4RA048	DPKB-48SK-7	M83733/7RB048	DPKB-48SY-7	M83733/10RB064	DPKB-64PH-7
M83733/1RB064	DPKB-64PG-7	M83733/4RB064	DPKB-64SK-7	M83733/7RB064	DPKB-64SY-7	M83733/10RB071	DPKB-71PH-7
M83733/1RB071	DPKB-71PG-7	M83733/4RB071	DPKB-71SK-7	M83733/7RB071	DPKB-72SY-7	M83733/10RB71C	DPKB-71C15PH-7
M83733/1RB71C	DPKB-71C15PG-7	M83733/4RB71C	DPKB-71C15SK-7	M83733/7RB71C	DPKB-71C15SY-7	M83733/10RB078	DPKB-78PH-7
M83733/1RB078	DPKB-78PG-7	M83733/4RB078	DPKB-78SK-7	M83733/7RB078	DPKB-78SY-7	M83733/10RB101	DPKB-101PH-7
M83733/1RB101	DPKB-101PG-7	M83733/4RB101	DPKB-101 SK-7	M83733/7RB101	DPKB-101 SY-7	M83733/11RA018	DPKA-18PZ-7
M83733/1RB185	DPKB-G185PG-7	M83733/4RB185	DPKB-G185SK-7	M83733/8RA018	DPKA-18PY-7	M83733/11RA032	DPKA-32PZ-7
M83733/2RA018	DPKA-18SX-7	M83733/5RA018	DPKA-18PC-7	M83733/8RA032	DPKA-32PY-7	M83733/11RA051	DPKA-51PZ-7
M83733/2RA032	DPKA-32SX-7	M83733/5RA032	DPKA-32PC-7	M83733/8RA051	DPKA-51PY-7	M83733/11RB048	DPKB-48PZ-7
M83733/2RA051	DPKA-51SX-7	M83733/5RA051	DPKA-51PC-7	M83733/8RB048	DPKB-48PY-7	M83733/11RB064	DPKB-64PZ-7
M83733/2RA131	DPKA-G131SX-7	M83733/5RA131	DPKA-G131 PC-7	M83733/8RB064	DPKB-64PY-7	M83733/11RB071	DPKB-71PZ-7
M83733/2RB048	DPKB-48SX-7	M83733/5RB048	DPKB-48PC-7	M83733/8RB071	DPKB-71PY-7	M83733/11RB71C	DPKB-71C15PZ-7
M83733/2RB064	DPKB-64SX-7	M83733/5RB064	DPKB-64PC-7	M83733/8RB71C	DPKB-71C15PY-7	M83733/11RB078	DPKB-78PZ-7
M83733/2RB071	DPKB-71SX-7	M83733/5RB71C	DPKB-71C15PC-7	M83733/8RB078	DPKB-78PY-7	M83733/11RB101	DPKB-101 PZ-7
M83733/2RB71C	DPKB-71C15SX-7	M83733/5RB078	DPKB-78PC-7	M83733/8RB101	DPKB-101PY-7	M83733/12RA018	DPKA-18SH-7
M83733/2RB078	DPKB-78SX-7	M83733/5RB101	DPKB-101PC-7	M83733/9RA018	DPKA-1BPM-7	M83733/12RA032	DPKA-32SH-7
M83733/2RB101	DPKB-101SX-7	M83733/5RB185	DPKB-G185PC-7	M83733/9RA032	DPKA-32PM-7	M83733/12RA051	DPKA-51SH-7
M83733/3RA018	DPKA-18PX-7	M83733/5RB071	DPKB-71PC-7	M83733/9RA051	DPKA-51PM-7	M83733/12RB048	DPKB-48SH-7
M83733/3RA032	DPKA-32PX-7	M83733/6RA018	DPKA-18PF-7	M83733/9RB048	DPKB-48PM-7	M83733/12RB064	DPKB-64SH-7
M83733/3RA051	DPKA-51PX-7	M83733/6RA032	DPKA-32PF-7	M83733/9RB064	DPKB-64PM-7	M83733/12RB071	DPKB-71SH-7
M83733/3RA131	DPKA-G131PX-7	M83733/6RA051	DPKA-51PF-7	M83733/9RB071	DPKB-71PM-7	M83733/12RB71C	DPKB-71C15SH-7
M83733/3RB048	DPKB-48PX-7	M83733/6RA131	DPKA-G131 PF-7	M83733/9RB71C	DPKB-71C15PM-7	M83733/12RB078	DPKB-78SH-7
M83733/3RB064	DPKB-64PX-7	M83733/6RB048	DPKB-48PF-7	M83733/9RB078	DPKB-78PM-7	M83733/12RB101	DPKB-101SH-7
M83733/3RB071	DPKB-71PX-7	M83733/6RB064	DPKB-64PF-7	M83733/9RB101	DPKB-101PM-7		
M83733/3RB71C	DPKB-71C15PX-7	M83733/6RB071	DPKB-71PF-7				
M83733/3RB078	DPKB-78PX-7	M83733/6RB71C	DPKB-71C15PF-7				
M83733/3RB101	DPK- 101PX-7	M83733/6RB078	DPKB-78PF-7				
M83733/3RB185	DPKB-G185PX-7	M83733/6RB101	DPKB-101 PF-7				
		M83733/6RB185	DPKB-G185PF-7				



Dimensions shown in inch (mm)
Specifications and dimensions subject to change

www.ittcannon.com

Test Data

The following is a presentation of the certified capabilities of Cannon's DPK, high performance, rectangular, rack and panel series connectors with respect to critical qualification performance and design requirements of MIL-C-83733. The data presented herein is a condensation of authentic qualification test data extracted from the original qualification reports on file at the ITT Cannon Test Laboratory.

The successful completion of the conducted qualification program clearly demonstrates the compliance of ITT Cannon, DPK series connectors and contacts to meet or exceed the performance requirements of MIL-C-83733.

Identification of Qualification Specimens

The DPK connectors listed below represent the description and identification of the test specimens

subjected to the qualification test sequence of MIL-C-83733.

- DPKA-G-131PC-7 (Receptacle) DPKB-G185PC-7 (Receptacle)
- DPKA-G131SK-7 (Plug) DPKA-G185SK-7 (Plug)
- DPKA-G-131PC-7 (Receptacle) DPKB-G185PC-7 (Receptacle)

Table I below, lists the conducted tests executed in accordance with the applicable test paragraphs of MIL-C-83733, with the Test Level, Parameter Limits and Measured Values listed in Table 11.

TABLE 1 TEST PERFORMED

Test Description	Test Description	Test Description	Test Description
Examination Of Product	Contact Separating Forces	Low Level Contact Resistance	Moisture Resistance
visual Examination	Connector Mating and Unmating Forces	Thermal Shock	Altitude Immersion
Sample Preparation	Contact Retention	Crimp Potential Drop	Insert Retention
Insulation Resistance - 25°C	Endurance	Vibration (Random)	Corrosion
Withstanding Voltage - Sea Level	Gold Plating Porosity	Physical Shock	Analyses
Withstanding Voltage - Altitude	Temperature Life	Ozone Exposure	Service and Storage Life
Contact Resistance	Insulation Resistance - 200°C	Fluid Immersion	Gases and Toxic or Corrosive Fumes

TABLE II

Test or Environment	Test Level or Special Requirements	Parameters Limits	Measured Values or Comments
Examination Of Product visual Examination Sample Preparation Insulation Resistance - 25°C Withstanding Voltage - Sea Level Withstanding Voltage - Altitude Contact Resistance	Assure compliance with: a) Applicable detail specifications and control drawings b) Materials c) Design and construction d) Dimensional e) Finish f) Product identification g) Workmanship	Compliance to applicable detail specification and control drawings.	Product submitted accompanied by Q.A. certificates of compliance, complied with the applicable acceptance requirements for qualification testing.
VISUAL EXAMINATION	Visual examination of qualification test specimens for completeness, workmanship, identification and /or other detrimental conditions.	Visual examination acceptance.	No visible detection of any condition detrimental to normal function.
SAMPLE PREPARATION	MIL-W-16878/4A, 28 AWG (min. dia.) and 22 AWG (max. dia.) wire. Daniels WA22A crimping tool. M22520/2-06 and M22520/2-09 contact positioner for resp.22D size socket and pin. MS7495A22M insertion and MS27495R22M removal tool.	Assemblies to conform with specified wiring and termination requirements.	Qualification test specimens prepared and terminated in accordance with specified wiring requirements. No difficulties encountered during wiring operation.
INSULATION RESISTANCE [25°C (77 F)]	Unmated condition. 50% of contact complement measured. Between adjacent contact pairs and each contact and connector shell.	5.1 Gigohms minimum at 500 Vdc. Electrification Time 120 secs. maximum.	Insul. res. range (ohms) (25°C) DPKA Adj. Cont. Cont./Shell 300G-1.0T 1.1T-1.8T DPKB 400G-1.6T 1.1T-20T (Ganged parallel test circuits)
DIELECTRIC WITHSTANDING VOLTAGE (SEA LEVEL)	Unmated condition. 50% of contact complement measured. Test voltage 1350 Vac/rms-60hz, applied between adjacent contact pairs and each contact and connector shell.	No electrical breakdown, flashover or excessive current leakage.Electrification 2 secs. minimum.	No evidence of breakdown or flashover Leakage ≤ 5mA. (Ganged Parallel test circuits)
SALT SPRAY (CORROSION)	Method 101, test condition B. (48 hours) unmated. Salt solution 5% by weight. S.G. 1.026 to 1.040 at 22.8°C-23.9°C (73°F-75°F). Solution pH6.5 to 7.2 and chamber temp 33.9°C to 36.1°C (93°F to 97°F).	Visual examination. No degradation of normal connector functions.	No detrimental corrosive attack on connector's surface finish or contacts.
CONTACT RESISTANCE [AT 25°C AND 200°C (77 F AND 392 F)]	Mated condition 20% of contact complement tested. Test circuit per Fig. 2 measured across points YY performed at 25°C and 200°C (77°F and 392°F).	Max. Voltage Drop (MV) Wire 25°C 200°C Size (77 F) (392 F) 28 8 19 22 14 25	MV-Drop Range. (25°C) Wire Adc Range Avg. Size (mV) (mV) 28 1.5 2.3-5.2 3.8 22 5.0 6.3-10 8.2 (200°C) 28 1.5 9-17 11.8 22 5.0 16-21 17.8
CONTACT SEPARATING FORCES	100% of socket contact complement measured. Separating force measured on steel test pin .0294 ±.0001 (0.747 ±0.002) dia. insertion depth .205 (5.21) min. from insert face.	Separating Force (ounce-force) Min. Max. 0.6 4.9	Separating force range (ounce-force) DPKA Sep. Force Avg. Force 1.3-4.1 2.4 DPKB 1.0-2.9 2.0
CONNECTOR MATING AND UNMATING FORCES	Mating dept. .390 (9.91) panel spacing. Total of 10 cycles mating and unmatings. Forces measured on 10th cycle.	Axial mating and unmating forces 175 pounds-force maximum.	Mating/Unmating Force (pound-force) Mate Unmated DPKA 145 34 DPKB 150 72 Forces obtained on 10th cycle.
CONTACT RETENTION	Unmated. 50% of contacts measured. 10.0 lbf applied to contact engaging end. Zero reference at 2.0 lbf preload. Displacement measured under spec. load.	Max. contact displacement under 10.0 lbf load .011 (0.28) maximum.	Contact Displacement Range (inch) DPKA Avg. Pins 0.002-0.003 0.0027 Sockets 0.002-0.004 0.0031 DPKB Pins 0.002-0.004 0.0027 Sockets 0.002-0.003 0.0026
ENDURANCE (DURABILITY)	Mating dept. .450 (11.43) panel spacing. Total of 500 cycles mating and unmating at a rate of 300 cycles/hour maximum.	Withstand 500 cycles of durability conditioning without detrimental effects to function.	No detrimental damage. Connectors fully functional.

Dimensions shown in inch (mm)
Specifications and dimensions subject to change

www.ittcannon.com



Test Data

(TABLE II Continued)

Test or Environment	Test Level or Special Requirements	Parameters Limits	Measured Values or Comments
THERMAL SHOCK	Mated condition. Five continuous cycles of temperature change, 30 mins. exposure at each temp. extreme constitutes one cycle. Transfer time between chambers 2 mins. max. temp. extremes: - 54 ± 3°C and 200 ± 3°C (-??' +_ 5.4°F and 392 ± 5.4°F).	Withstand temperate cycling. No damage.	No apparent damage.
CRIMP POTENTIAL DROP	20% of the contacts in each connector measured. Test circuit per Fig. 2 measured across points X-X and X'-X'. Contact/Wire-size Test Current (Adc) 22D/28 1.5 22D/22 5.0	Max. crimp potential drop: Wire Size M.V. 28 2.8 22 7.0	Crimp mV drop range. DPKA (sockets) Adc Range Avg. 1.5 1.7-2.1 1.8 (Pins) 1.5 1.1-1.6 1.3 DPKB (sockets) Adc Range Avg. 5.0 1.8-2.4 2.1 (Pins) 5.0 1.4-1.8 1.5
DIELECTRIC WITHSTANDING VOLTAGE (ALTITUDE)	Mated condition. 50% of contact complement measured. Performed at simulated altitude of 70,000 ft. (33.7 mm Hg pressure) Test voltage 825 Vac/ms-60 Hz, applied between adjacent contact pairs and each contact and connector shell.	Same as at sea level conditions.	No evidence of breakdown or flashover. Leakage ≤.5mA. (Ganged Parallel test circuits)
INSULATION RESISTANCE ELEVATED TEMP.[200°C (392°F)]	Unmated condition. 50% of contact complement measured. Test points identical to those measured at 25°C (77°F). Oven ambient controlled at 200°C (392°F). Stabilization period 30 minutes minimum.	204 Megohms minimum at 500 Vdc. Electrification time 120 secs. maximum.	Insul. Res. range (ohms) [200°C (392°F)] DPKA Adj. Cont. Cont./Shell 1.4G-10G 2.4G-4.0G DPKB 0.75G-10G 2.26G-5.0G (Ganged parallel test circuits)
VIBRATION (RANDOM)	Method 214, Test condition II, Letter 'G'. Test level envelope per figure and table 214-2. Contact circuit senses wired far current discontinuity monitoring. Eight hours duration in each of three mutually peipendicular axes. Connector mating depth .450 (11.43) panel spacing.	No current discontinuity ≥ 1.0 microsec. No cracking, breaking or loosening of connector parts.	Connectors met random vibration requirements. No electrical discontinuity detected.
PHYSICAL SHOCK	Mated condition, .450 (11.43) panel spacing. Shock pulse duration I I ± 1 mS, waveshape terminal peak smooth, peak amplitude 20g. Contact circuit series wired for current discontinuity monitoring. One shock pulse in each of three mutually perp. axes.	No current discontinuity ≥ 1.0 microsec. No cracking, breaking or loosening of connector parts.	Connectors met physical shock requirements. No electrical discontinuity or damage detected.
MOISTURE RESISTANCE	Method 106, (Step 7b) ommed) Mated condition. 10 days humidity and temperature cycling. At end Step 6 final cycle at 25°C (77°F) and 90-98% RH insulation resistance in asured 100% between each and ail other contacts and the shell in parallel circuit.	Insulation resistance at final humidity cycle 102 Megohms minimum at 50 Vdc.	Insul. Res. range (ohms) final humidity cycle. DPKA DPKB 1.66-500G 1.6-500G Avg: 224G Avg: 190G
ALTITUDE IMMERSION	Mated condition. Immersed in 5% sail solution by weight. Unsealed wire ends exposed to chamber atmosphere. Simulated test altitude 75,000 ft, (1.0 inch Hg). 30 mins. at altitude followed by 15 mins. at room ambient, Repeat for total of 3 cycles. Insul. res. and OWV measured 100% of contact complement at room ambient and submerged.	Insulation resistance 1.2 Gigohm minimum at 5 Vdc. DWV 1350 Vac/rms - 60 Hz, electrification time 60 secs. minimum. No breakdown, flashover or leadage ≤ 2 mA,	Final insul. Res ranges (ohms). DPKA DPKB 1.5T-4.5T 0.7-3.5T Avg. 1.9T Avg: 1.3T DWV - No evidence of insert movement and /or dislocation from normal position
INSERT RETENTION	Unmated. 46 1bf/in. ² pressure lead applied to each inert face at 5 1bf/in ² /sec., maintained for 5 secs. min. at specified load.	No insert disiocation from normal position in the connector shell.	No evidence of insert movement and/or dislocation from normal position.
OZONE EXPOSURE	Unimated. Ozone concentration 0.010 to 0.015 percent by volume. Exposure period 2 hours minimum at room temperature.	No deterioration.	No evidence of ozone effects.
FLUID IMMERSION	Fluid immersion rest fluids and procedures per Table 4: Sample No. Test Fluid 4-1P/R MIL-L-7808 4-2P/R MIL-L-23699 4-3P/R M2-V CHEVRON 4-4P/R MIL-H-5606 4-5P/R MIL-A-8243 4-6P/R MIL-C-25769 4-7P/R MIL-T-5624 (JP-5) 4-8P/R Coolanol-25 4-9P/R Regular (Leaded commercial auto-gasoline 4-10P/R Solvent (a) MIL-STD-202) 4-11P/R Solvent (b) MIL-STD-202) 4-12P/R Solvent (c) MIL-STD-202)	No detrimental damage of effects to connector performance. Axial Mate and unimate forces after fluid immersion 175 1bf max.	Other than evidence of normal light swelling of the connector resilient seals, the samples did not exhibit any deritmental affects. Mateability was not imparied. After Fluid Immersion Mating/Unmating forces (Pound-Force) DPKA Mate Unmated DPKB Mate Unmated 4-1P/R 125 27 4-7P/R 138 71 4-2P/R 125 31 4-8P/R 141 57 4-3P/R 127 35 4-9P/R 137 63.5 4-4P/R 132 35 4-10P/R 145 76 4-5P/R 132 63 4-11P/R 150 81 4-6P/R 123 55 4-12P/R 148 86
GOLD PLATING POROSITY	Unwired. wouisenbled contact bodies. One part (by volume) concentrated Nitric Acid (S.G.-1.42) to we part distilled water. 30 secs. minimum immersion period.	No visible reaction (bubbles forming) to reagent.	No evidence of reaction to reagent.
TEMPERATURE LIFE W/CONTACT LOADING	Wired mated condition, with contacts under specific load: #220 (5 lbs.); #16 12.5 lbs. A current of 100 MA was applied during life of test. Test duration, 1000 hours at temperature of + 200°C (392°F).	Withstand temp life. No damage. No discontinuity higher than 1.0 microsecond. No contact dislodging order load.	No evidence of contact dislodging and/or electrical discontinuity of 1.0 microsecond or greater during the speified temperature life exposure under contact loading conditions. All post test requirements were met.

Conclusion

All subject test specimens, connector components, materials, accessories and contacts covered by this report satisfied and/or exceeded the specified requirement.

The successful completion of the qualification program as reported herein, demonstrates the capabilities of the subject ITT Cannon DPK series connectors to comply with stringent verification

qualification requirements in accordance with MIL-C-83733. On the basis of testing, the DPK connector series was granted full OPI status to MIL-C-83733.



Dimensions shown in inch (mm)
Specifications and dimensions subject to change

www.ittcannon.com

Weights

The following are weights for DPK connector assemblies, mounting hardware, contacts, and sealing plugs. All connector weights are listed less contacts (FO) and mounting hardware. The total connector weight is obtained by adding mounting hardware, contacts, and sealing plugs weight to the connector assembly weight.

Example:

DPKB-101SK-7 (with 90 contacts and 11 sealing plugs)

	Weight Pounds	Weight Grams
DPKB-101SG-7-FO	.2332	105.78
Type K Spring Mount	.0825	37.42
90 Number 20 Socket Contacts	.0639	28.98
11 Number 20 Sealing Plugs	.0020	.88
	.3816	173.06
Maximum Connector Weight		

Part Number (Description)	Maximum Weight	
	Lbs.	Grams
DPKA-18PG-7-F0	.1474	66.86
DPKA-18SG-7-F0	.1496	67.86
DPKA-32PG-7-F0	.1496	67.86
DPKA-18SG-7-F0	.1518	68.86
DPKA-51PG-7-F0	.1529	69.35
DPKA-51SG-7-F0	.1551	70.35
DPKA-G131PG-7-F0	.1045	47.40
DPKA-G131SG-7-F0	.1077	48.85
DPKB-48PG-7-F0	.2398	108.77
DPKB-48SG-7-F0	.2486	112.76
DPKB-59W7PG-7-F0	.2354	106.78
DPKB-59W7SG-7-F0	.2442	110.78
DPKB-64PG-7-F0	.2354	106.78
DPKB-64SG-7-F0	.2442	110.78
DPKB-71PG-7-F0	.2288	103.78
DPKB-71SG-7-F0	.2332	105.78
DPKB-71C15PG-7-F0	.2288	103.78
DPKB-71C15SG-7-F0	.2332	105.78
DPKB-78PG-7-F0	.2266	102.78
DPKB-78SG-7-F0	.2288	103.78
DPKB-101PG-7-F0	.2288	103.78
DPKB-101SG-7-F0	.2332	105.78
DPKB-G185PG-7-F0	.1628	73.85
DPKB-G185SG-7-F0	.1650	74.85
#12 Pin, 030-9185-003	.00298	1.353
#12 Skt, 030-9186-003	.00291	1.318
#16 Pin, 030-9205-007	.00135	.611
#16 Skt, 030-9206-006	.00146	.664
#20 Pin, 030-9173-006	.00062	.280
#20 Skt, 031-9174-004	.00071	.322
#22D Pin, 030-2042-000	.00021	.093
#22D Skt, 031-1147-000	.00025	.111
#12 Shielded Pin, 249-1825-001	.00206	.943
#12 Shielded Skt, 249-1826-000	.00258	1.168
#8 Coaxial Pin, 59W7 Layout	.00420	1.910
#8 Coaxial Skt, 59W7 Layout	.00650	2.948
Type C Bushing, 012-0515-000 (4 reqd)	.00606	2.750
Type K Spring Mtg Captive (non-rotate)	.08250	37.42
Type F Nut (4 reqd)	.00072	.325
Type G Spring Mtg 231-0019-000 (4 reqd)	.01180	5.350
Size 22; 225-1013-000	.00006	.027
Size 20; 225-0070-000	.00018	.080
Size 16; 225-0071-000	.00036	.163
Size 12; 225-0072-000	.00064	.291
SEALING PLUGS		

Dimensions shown in inch (mm)
Specifications and dimensions subject to change

www.ittcannon.com



Receptacle (Pin Contacts)

BASIC RECEPTACLE SHELL DIMENSIONS

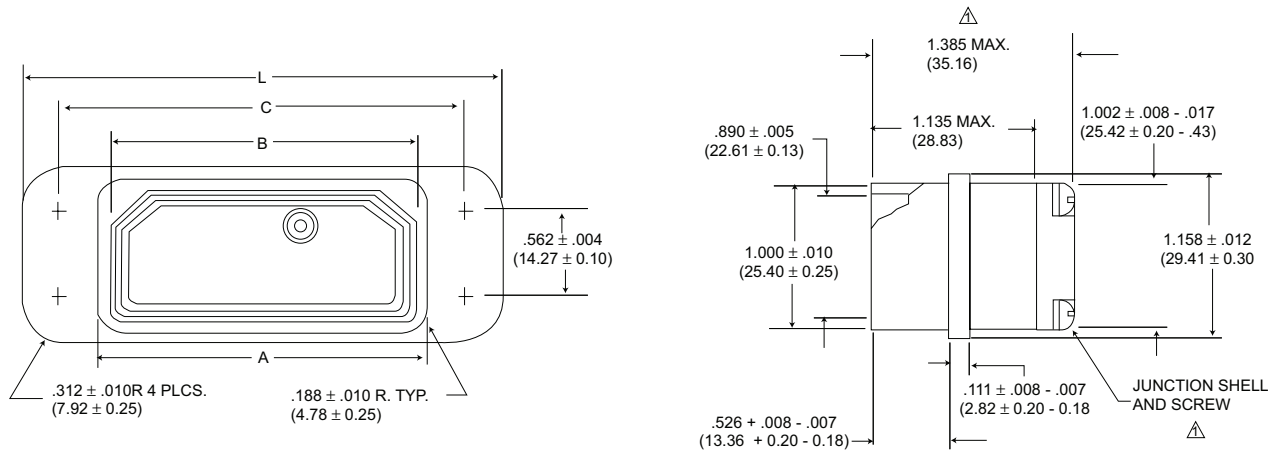

△ Junction shell and screws are not supplied on - G131 and -G185 layouts.

SHELL SIZE	A	B	C	L	N Staggered †
DPKA*P**	2.085 (52.96)	1.976 (50.19)	2.580 (65.58)	3.030 (76.96)	2.150 (54.61)
DPKB*P**	3.385 (85.98)	3.281 (83.34)	3.880 (98.53)	4.330 (109.98)	3.450 (87.63)
DPKB*P**	3.372 (85.65)	3.261 (82.83)	3.870 (98.32)	4.300 (109.22)	3.430 (87.12)

†See Page 85 Style M and Z

DPK TYPES

Mounting Style A

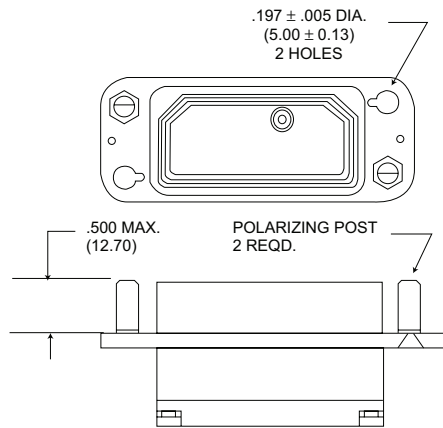

Mounting Dimensions for Coupling Nut Assemblies

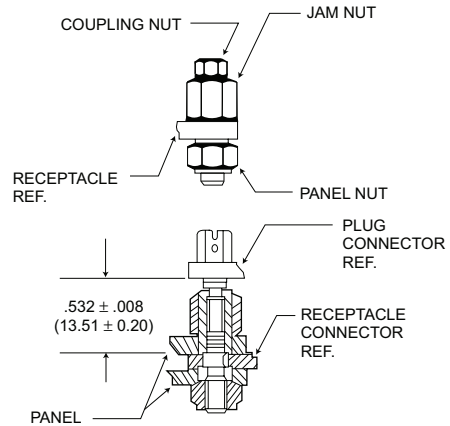

DPK/MIL-C-83733 TYPES

Mounting Style G
Standard Hole Mounting MIL-C-83733/1(USAF)

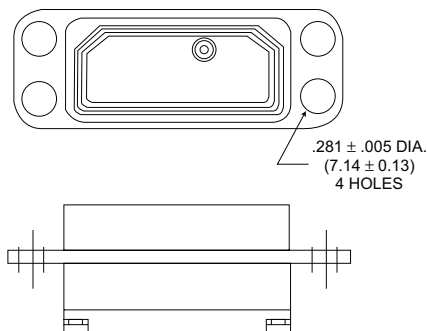

Mounting Style F Clinch Nut Mounting
MIL-C-83733/6(USAF)

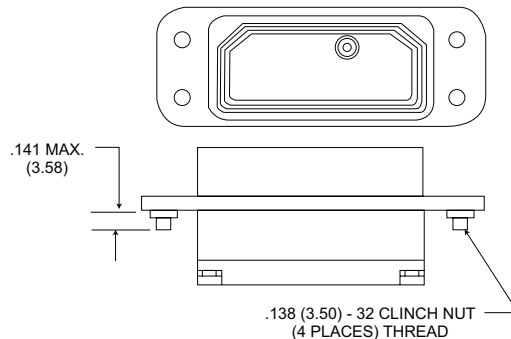

Dimensions shown in inch (mm)
Specifications and dimensions subject to change

www.ittcannon.com

Receptacle/Configurations (Pin Contacts)

DPK/MIL-C-83733 TYPES

Mounting Style C
Bushing Mounting MIL-C-83733/5(USAF)

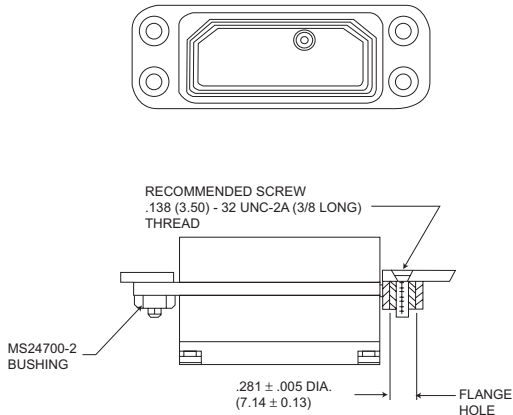

Mounting Style X
With Guide Sockets MIL-C-83733/3(USAF)

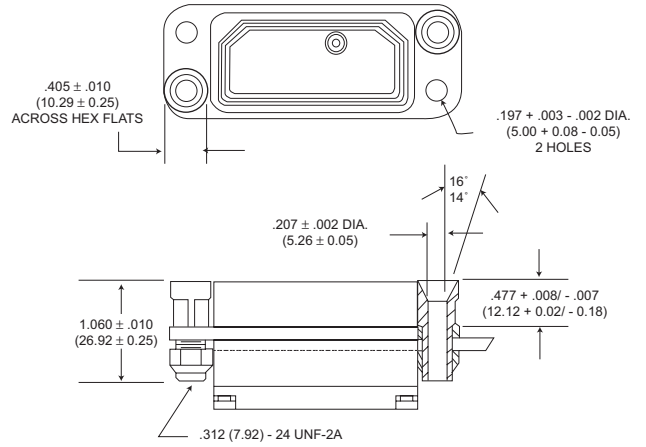

DPK/MIL-C-83733 TYPES

Mounting Style Y
With Guide Pins MIL-C-83733/8(USAF)

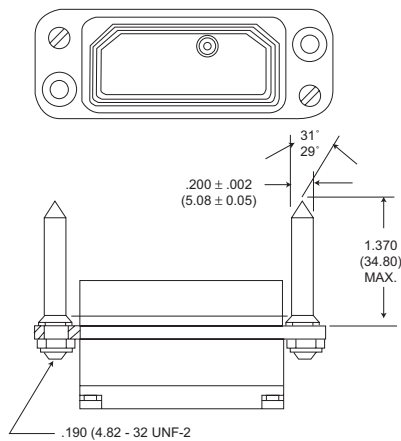

Mounting Style M
Staggered Standard Hole Mounting MIL-C-83733/9(USAF)

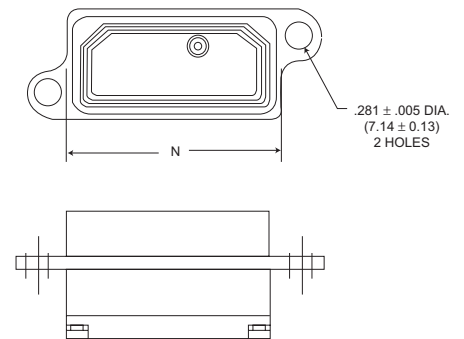

Mounting Style H
Staggered Bushing Mounting MIL-C-83733/10(USAF)

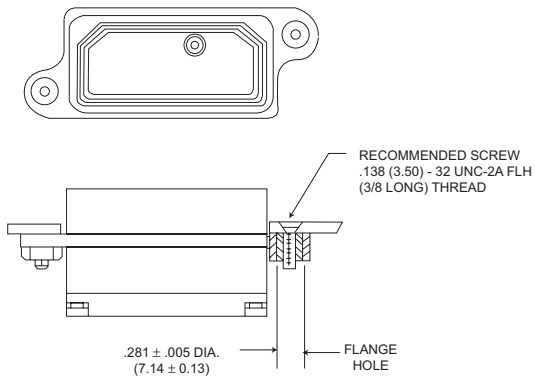

Mounting Style Z
Staggered Clinch Nut Mounting MIL-C-83733/11(USAF)

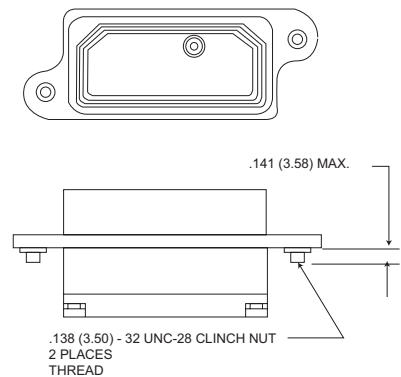

Dimensions shown in inch (mm)
Specifications and dimensions subject to change

www.ittcannon.com



Plug/Configurations (Socket Contacts)

Basic Plug
Shell Dimensions

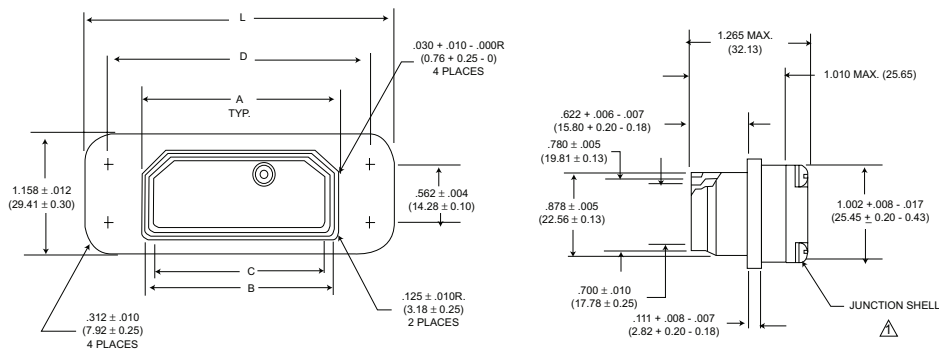

SHELL SIZE	A	B	C	D	L	N Staggered †
DPKA*S**	1.959 (49.76)	1.864 (47.35)	1.780 (45.21)	2.580 (65.53)	3.030 (76.96)	2.150 (54.61)
DPKB*S**	1.946 (49.43)	1.853 (47.07)	1.763 (44.78)	2.570 (65.28)	3.000 (76.20)	2.130 (54.10)
DPKC*S**	3.259 (82.78)	3.164 (80.37)	3.080 (78.23)	3.880 (96.52)	4.330 (109.98)	3.450 (87.63)
DPKD*S**	3.246 (82.45)	3.153 (80.09)	3.063 (77.80)	3.870 (98.30)	4.300 (109.22)	3.430 (87.12)

⚠ Junction shell and hardware are not supplied on -G131 and -G185 layouts.

† See page 85 Style M and H

DPK Styles

Mounting Style A

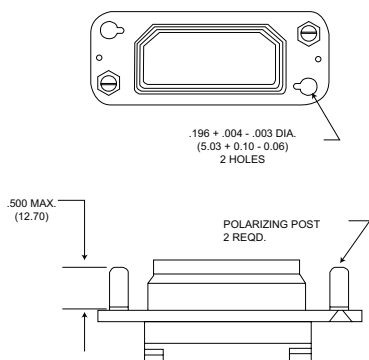

Mounting Spacing Dimensions
For Jackscrew Assemblies

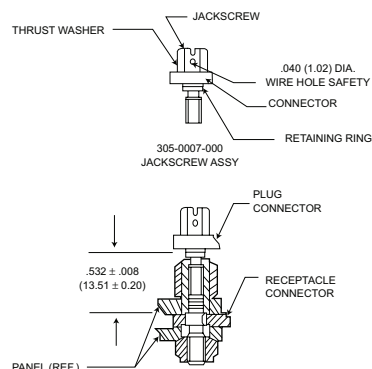

DPK/MIL-C-83733 TYPES

Mounting Style K - MIL-C-83733/4(USAF)
With Captive Springs

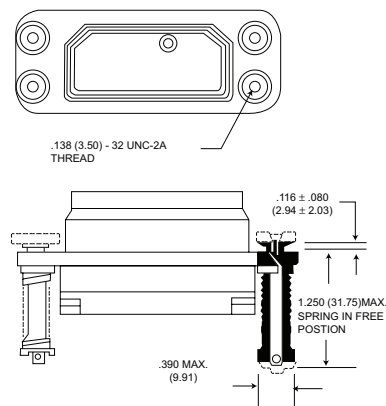

Mounting Style X - MIL-C-83733/2(USAF)
With Guide Pins and Spring Mounting

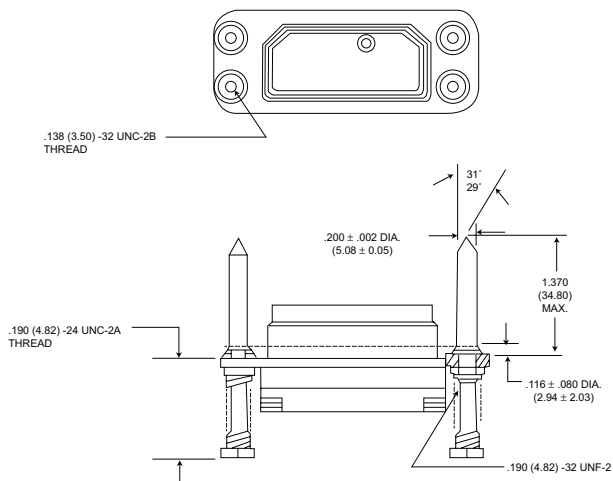

NOTES: 1. Springs are pre-loaded to 25 pounds each in free position.
2. Spring forces will be 118 pounds minimum at .500 (12.70) panel spacing and 176 pounds maximum at .390 (9.91) panel spacing

NOTES: 1. Springs are pre-loaded to 25 pounds each in free position.
2. Spring forces will be 59 pounds minimum at .500 (12.70) panel spacing and 88 pounds maximum at .390 (9.91) panel spacing

Plug/Configurations (Socket Contacts)

DPK/MIL-C-83733 TYPES

Mounting Style Y - MIL-C-83733/7(USAF)
With Guide Sockets and Spring Mounting

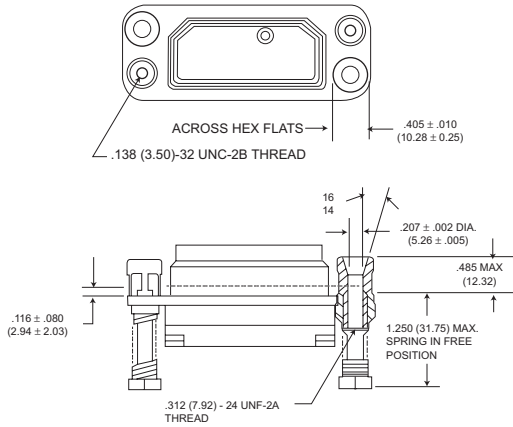

- NOTES: 1. Springs are pre-loaded to 25 pounds each in free position.
2. Spring forces will be 59 pounds minimum at .500 (12.70) panel spacing and 88 pounds maximum at .390 (9.91) panel spacing

Mounting Style H - MIL-C-83733/12(USAF)
Staggered Spring Mounting

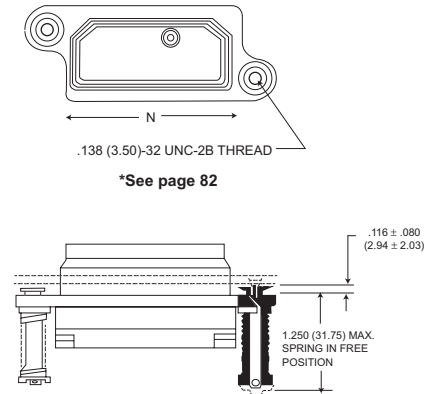

*See page 82

- NOTES: 1. Springs are pre-loaded to 25 pounds each in free position.
2. Spring forces will be 59 pounds minimum at .500 (12.70) panel spacing and 88 pounds maximum at .390 (9.91) panel spacing
3. This configuration must not be used on teh 131 or 185 contact layouts.

DPK Commercial Types

Mounting Style G
Standard Hole Mounting

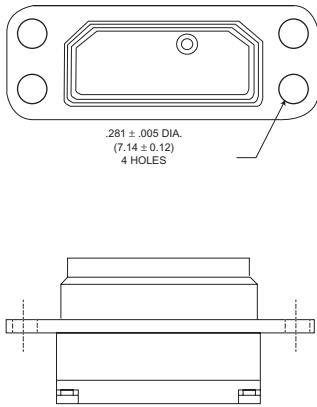

Mounting Style F
Clinch Nut Mounting

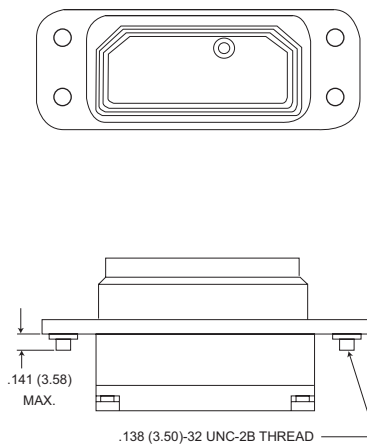

Mounting Style M
Mounting

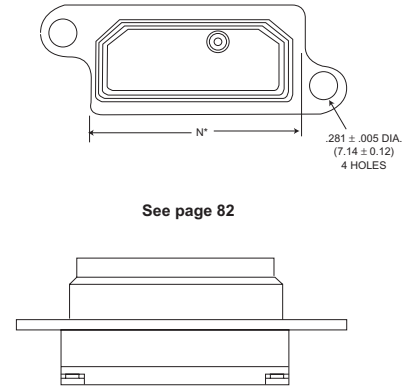

See page 82

Mounting Styles/Applications

DPK connectors for rectangular or staggered mounting are available in both two- and four-spring mount assemblies, or the same shelf style may be ordered to accommodate bushing assemblies. In the spring mount version the spring-loaded mechanism will compensate for a panel space variation of up to .070(1.78) while insuring electrical and environmental integrity.

DPK connectors are also available with polarizing posts, accommodations for jackscrews, and coupling nuts for cord-to-card and cord-to-panel applications. Another shelf style has two or four mounting holes fitted with captive clinch nuts. For mounting dimensions of the various mounting styles shown here please refer to page 91.

Style A
Mounting style A is designed for cord-to-panel and cord-to-cord applications. Connectors are supplied with two polarizing posts installed and provisions for installation of two jackscrew assemblies or two coupling nut assemblies. (Replaces Mounting Style B.)

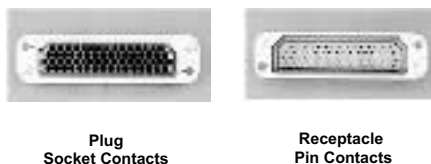

Ordered Separately

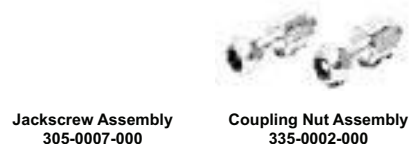

Style C
Mounting style C is designed for cord-to-panel or rack-to-panel applications. Connectors are supplied with (4) MS24700-2 bushings on the receptacle and 4 spring mount assemblies on the plug.



Supplied with Connector



Style F
Mounting Style F is designed for rack-to-panel applications. Connectors are supplied with four captive clinch nuts installed.



Style G
Mounting style G is designed for rack-to-panel applications. Connectors are supplied with four .281(7.14) diameter holes which will accommodate either four MS24700-2 bushings or four 231-0019-000 spring mounts,

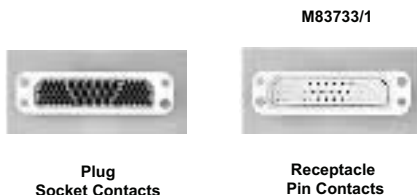

Ordered Separately

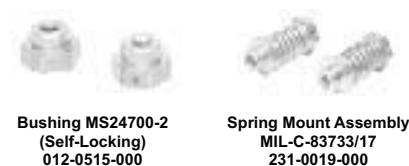

Style H
Mounting style H is designed for rack-to-panel applications. Connectors are supplied with two .281(7.14) diameter holes which are staggered. Two spring mounts are on the plug end two MS24700-2 bushings are on the receptacle.

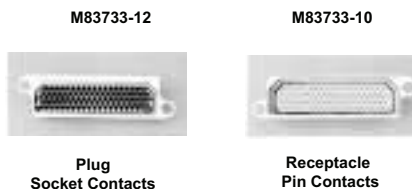

Supplied with Connector



Style K
Mounting style K is designed for rack-to-panel applications. Connectors are supplied with four captive, non-rotating spring mounts on the plug.



Style M

Mounting style M is designed for rack-to-panel applications. Connectors are supplied with two .281 (7,14) diameter holes which are staggered and will accommodate eight two MS24700-2 bushings or two 231-0019-000 spring mounts.

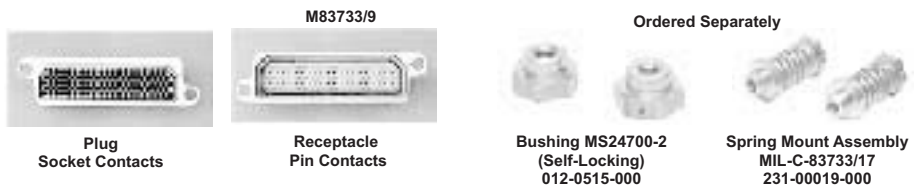

Style X

Mounting style X is designed for rack-to-panel applications where positive alignment is required before connectors are mated. Plug has two guide pins and two spring mounts (MIL-STO-1533); receptacle has two guide sockets and two .197 (5.00) dia. holes.

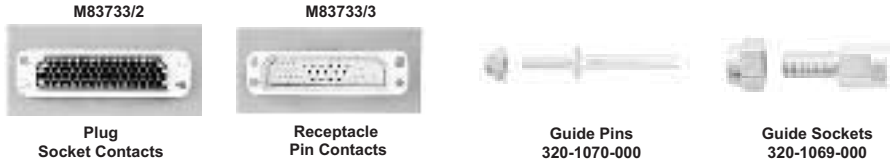

Style Y

Mounting style Y is identical to mounting style X, Xcept the guide sockets are on the plug and the guide pin and springs are on the receptacle.

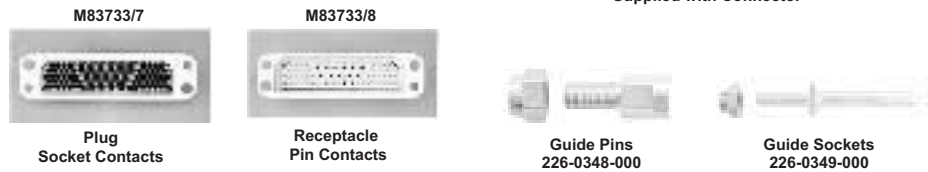

Style Z

Mounting style Z is designed for use in rack-to-panel applications. Connectors are supplied with two captive clinch nuts which are staggered.



MIL-C-83733 Connector Type	DPK Mtg. Style	Mating MIL-C-83733 Connector	DPK Mtg. Style
M83733/1 RECEPTACLE	G	M83733/4	K
M83733/2 PLUG	X	M83733/3	X
M83733/3 RECEPTACLE	X	M83733/2	X
M83733/4 PLUG	K	M83733/1	G
		M83733/5	C
		M83733/6	F
M83733/5 RECEPTACLE	C	M83733/4	K
M83733/6 RECEPTACLE	F	M83733/4	K
M83733-07 PLUG	Y	M83733/8	Y
M83733-08 RECEPTACLE	Y	M83733/7	Y
M83733-09 RECEPTACLE*	M	M83733/12	H
M83733-10 RECEPTACLE*	H	M83733/12	H
M83733-11 RECEPTACLE*	Z	M83733/12	H
M83733-12 RECEPTACLE	H	M83733/9	M
		M83733/10	H
		M83733/11	Z

*Not recommended for G131 and G185 layouts.

Polarization (Mounting Style A only)

Polarizing Post Alternate Positions

Pin inserts polarizing positions are 180° opposite socket insert polarizing positions. Shaded areas indicate extended portion of the polarizing post. Cord to panel DPK connectors are available in 35 alternate polarizing positions by changing indexing of the polarizing posts. Keystone corners and hexagonal posts provide this wide range of alternate positions.

Face view of socket insert plug connector engaging end.

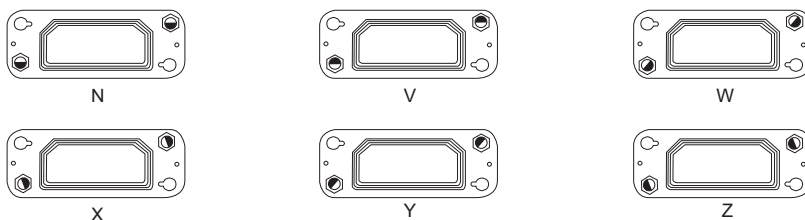

Contact Data

Standard Contacts

Contact Size	Type	Cannon Part Number	MIL-C-39029 Military Part Number	Crimp Tool	Insertion/Extraction Tool	Grommet Sealing Plug Part Number (Color)
12	Pin Skt.	030-9185-003 031-9186-003	M39029/4-113 M39029/5-118	M22520/1-01 with M22520/1-02 Turret	MIL-I-81969/14-04	225-0072-000 (Yellow)
16	Pin Skt.	030-9205-007 031-9206-006	M39029/4-111 M39029/5-116	M22520/2-01 with M22520/2-02 Turret	MIL-I-81969/14-03	225-0071-000 (Blue)
20	Pin Skt.	030-9173-006 031-9174-004	M39029/4-110 M39029/5-115	M22520/2-01 with M22520/2-02 Turret	MIL-I-81969/14-11	225-0070-000 (Red)
22	Pin Skt.	030-1975-008 031-1113-008	M39039/11-144 M39029/12-148	M22520/2-01 with M22520/2-23 Turret	MIL-I-81969/14-01	225-1013-000 (Black)
22D	Pin Skt.	030-2042-000 031-1147-000	M39029/58-360 M39029/57-354	M22520/2-01 with M22520/2-06 (Socket) Turret M22520/2-09 (Pin) Turret	MIL-I-81969/14-01	

Coaxial/Shielded Contacts

Coaxial	Type	Prefix	Cannon Part Number	Cable Accom.	DWV Voltage	Min./Max. O.D. Wire Accom.	Crimp Tool	Ins./Ext. Tool	Grommet Sealing Plug Part Number (Color)
Coaxial Contacts* △59W7 Arrangement Only	Plug Receptacle	G G	249-5500-012 249-5500-013	RG-316	500 VDC	.122 (3.10) .250 (6.35)	CCTC8 Outer M22520/2-01 M22520/2-30	CET-C8	225-0085-00 (White)
	Plug Receptacle	F F	249-5500-010 249-5500-011	RG-180/U	500 VDC	.122/250	CCTC9 Outer M22520/2-01 M22520/2-30	CET-C8	

*Plug coaxials go into plug connectors (59W7S inserts with socket contacts). Receptacle coaxials go into receptacle connectors ("P" inserts) with pin contacts (59W7P inserts with pin contacts).

Coaxial	Type	Cannon Part Number	MIL-C-39029 Part Number	Cable Accom.	Min./Max Cable Dia.	Crimp Tool	Locator	Ins./Ext. Tool	Grommet Sealing Plug Part Number (Color)
Size 12 Contact 71C15 Layout Only	Pin Socket	249-1825-001 249-1826-000	M39029/50-340 M39029/51-341	RG-179U	.081 (2.06) .158 (4.01)	.M22520/5-01 Outer M22520/2-01 Inner	.M22520/5-08 Outer M22520/2-30 Inner	CIET - 12	225-0072-000 (Yellow)

*Pin shielded contacts utilized in receptacle connectors (71C15P inserts).
Socket shielded contacts utilized in plug connectors (71C15S inserts).



Contact Arrangements

DPKA

Face View Pin Insert Shown

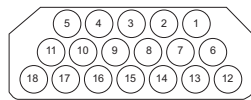

18
18 #12

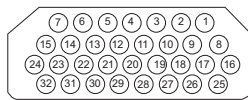

32
32 #16

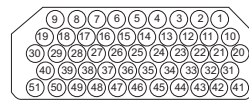

51
51 #20

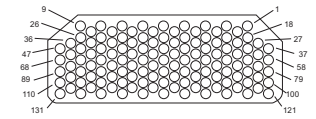

G131
131 #220

Layout
No. of Contacts
and Wire Size
Service Rating

I

I

I

M

DPKB

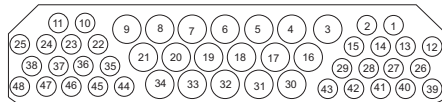

48
30 #16 (1,2,10-15,22-29,35-48),
18#12 (3-9,16-21,30-34)

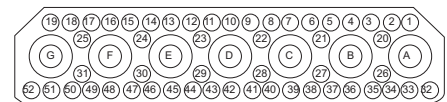

59W7
52 #20 (1-52)
7 Coax. (A-G)
#20: 1500 Coax: 1000
I & 500 VDC (Coax)

Layout
No. of Contacts
and Wire Size
Service Rating

The 59W7 Layout is sold less coaxial contacts, see page 86 for contact part number

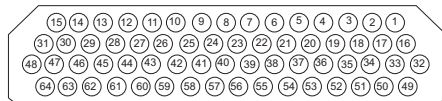

64
64 #16
I

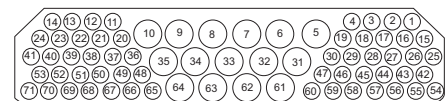

71
56#20 (1-4,11-30,36-60,65-71)
15 #12 (5-10,31-56,61-64)
I

Layout
No. of Contacts
and Wire Size
Service Rating

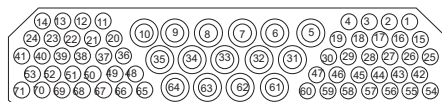

71C15
56 #20 (1-4,11-30,36-60,65-71)
15 Shielded #12 (5-10, 31-35,61-64)
#20: 1500: #12 Shielded: 500
1&500 VDC (Coax)

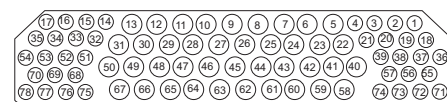

78
38 #20 (1-4,14-21,32-39,51-57,
68-78),40 #16 (5-13, 22-31,
40-50,58-67)
I

Layout
No. of Contacts
and Wire Size
Service Rating

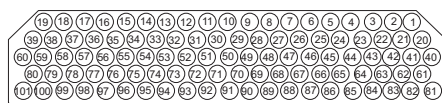

101
101 #20
I

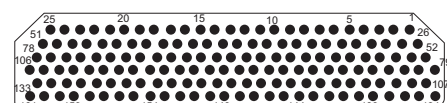

161*
161 #22
1000 VDC

Layout
No. of Contacts
and Wire Size
Service Rating

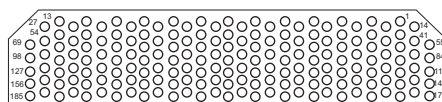

G185
185 #22D
M

Layout
No. of Contacts
and Wire Size
Service Rating

*P0S-ALINE DESIGN

In the 161 contact arrangement, the entire pin contact is recessed in and individual cavity in the plug connector. The socket contact is exposed and extends from the connector receptacle face. (Pin insulator accepts socket contacts.)

Dimensions shown in inch (mm)
Specifications and dimensions subject to change

www.ittcannon.com



Panel Cutout Dimensions

Mounting Styles

PG, SG SY, PY
 PC, PF, SF, S*A, S*B
 SX, PX, SK P*A, P*B

Figure 1.

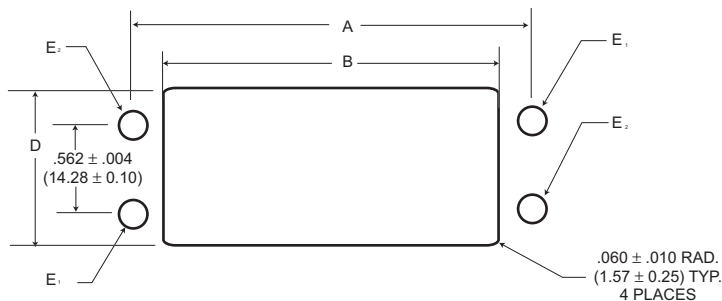

Mounting Styles

SH, SM

Figure 2.

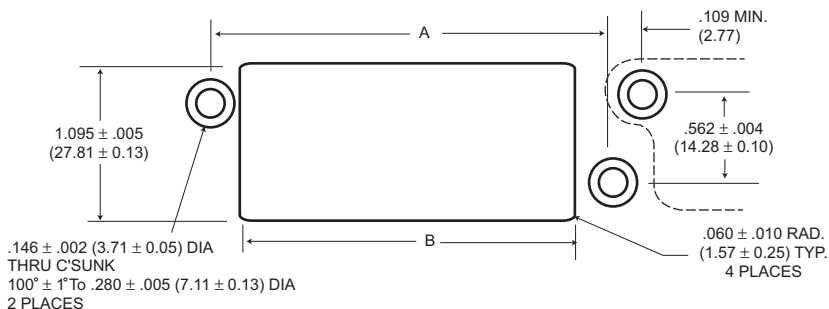

Mounting Styles

PM, PH, PZ

Figure 3.

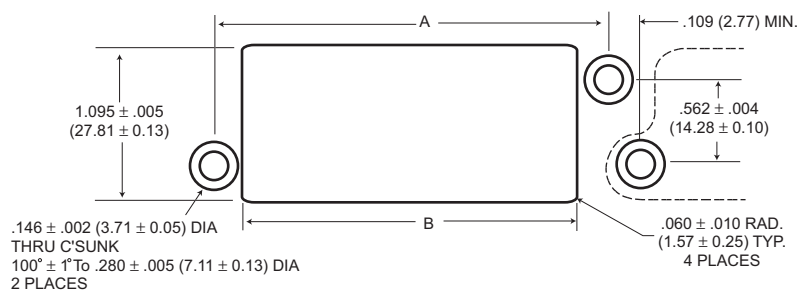

MIL-C-83733 Part No./ Mounting Style	DPK Mounting Styles	Figure Ref.	A ± .004 (± 0.10)		B ± .005 (± 0.13)		D ± .005 (± 0.13)		E ₁		E ₂	
			Shell Size A	Shell Size B	Shell Size A	Shell Size B	Shell Size A	Shell Size B	Shell Size A	Shell Size B	Shell Size A	Shell Size B
M83733/1/5/6	PG, SG, PC, PF, SF	1	2.578 (65.48)	3.875 (98.43)	2.103 (51.13)	3.400 (86.36)	1.022 (25.96)	1.022 (25.96)	.148 (3.76) .144 (3.66)	.148 (3.76) .144 (3.66)	.148 (3.76) .144 (3.66)	.148 (3.76) .144 (3.66)
M83733/2	SX	1	2.578 (65.48)	3.875 (98.43)	2.103 (51.13)	3.465 (88.01)	1.022 (25.96)	1.095 (27.81)	.148 (3.76) .144 (3.66)	.148 (3.76) .144 (3.66)	.430 (10.92) .420 (10.67)	.430 (10.92) .420 (10.67)
M83733/3	PX	1	2.578 (65.48)	3.875 (98.43)	2.103 (51.13)	3.465 (88.01)	1.022 (25.96)	1.095 (27.81)	.320 (8.13) .315 (8.00)	.320 (8.13) .315 (8.00)	.148 (3.76) .144 (3.66)	.148 (3.76) .144 (3.66)
M83733/4	SK	1	2.578 (65.48)	3.875 (98.43)	2.167 (55.04)	3.465 (88.01)	1.095 (27.81)	1.095 (27.81)	.148 (3.76) .144 (3.66)	.148 (3.76) .144 (3.66)	.148 (3.76) .144 (3.66)	.148 (3.76) .144 (3.66)
M8733/7	SY	1	2.578 (65.48)	3.875 (98.43)	2.167 (55.04)	3.465 (88.01)	1.095 (27.81)	1.095 (27.81)	.148 (3.76) .144 (3.66)	.148 (3.76) .144 (3.66)	.430 (10.92) .420 (10.67)	.430 (10.92) .420 (10.67)
M83733/8	PY	1	2.578 (65.48)	3.875 (98.43)	2.167 (55.04)	3.465 (88.01)	1.095 (27.81)	1.095 (27.81)	.430 (10.92) .420 (10.67)	.430 (10.92) .420 (10.67)	.148 (3.76) .144 (3.66)	.148 (3.76) .144 (3.66)
M83733/9/10/11	PM, PH PZ	2	2.578 (65.48)	3.875 (98.43)	2.167 (55.04)	3.465 (88.01)	1.095 (27.81)	1.022 (25.96)	-	-	-	-
M83733/12	SH, SM	3	2.578 (65.48)	3.875 (98.43)	2.095 (53.21)	3.400 (86.36)	1.095 (27.81)	1.095 (27.81)	-	-	-	-
N/A	S*A, S*B, P*A, P*B	1	2.578 (65.48)	3.875 (98.43)	2.103 (51.13)	3.465 (88.01)	1.022 (25.96)	1.095 (27.81)	.301 (7.65) .294 (7.45)	.301 (7.65) .294 (7.45)	.301 (7.65) .294 (7.45)	.301 (7.65) .294 (7.45)

Mounting Assembly-Jackscrew/Coupling Nut

Installation of jackscrew and coupling nuts in mounting style A and B.

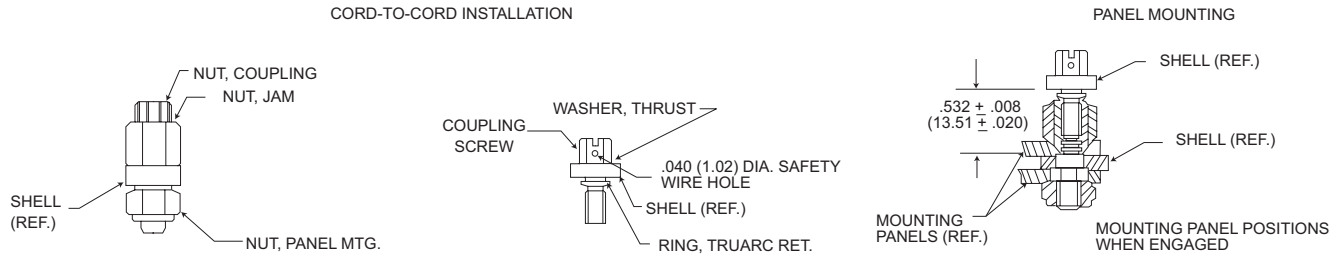

Mounting Assembly-Bushing/Spring Mount

Installation of mounting styles utilizing bushing and spring mount assemblies.

PLUGS

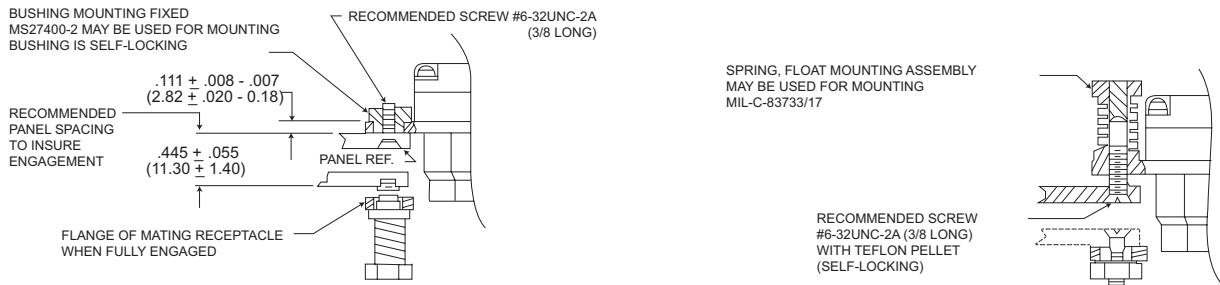

RECEPTACLES

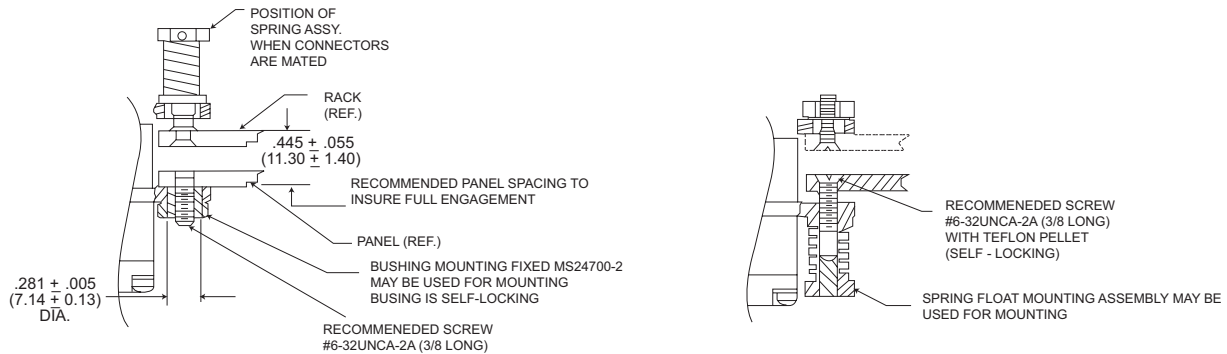

Mating Forces

The axial forces required to fully mate or separated the plug and receptacle shall not exceed the values listed.

Mating force at .390 (9.91) minimum spacing

Shell Size	Without mounting accessories	Spring mounting	
		Maximum	Normal
A	70 max.	176	145
B	95 max.	176	150

For connectors using spring mounting, the mating forces become a function of the spring loading. Values listed apply to connectors mounted as specified above at minimum panel spacing.

Dust Covers

PLASTIC TYPE

Series	Style		Standard	Conductive
DPKA	Receptacle	DPKA-60	025-0773-000	025-0773-001
	Plug	DPKA-59	025-0772-000	025-0772-001
DPKB	Receptacle	DKPB-60	025-0774-000	025-0774-001
	Plug	DKPB-59	025-0758-000	025-1195-000

Assembly/Shielded Contacts

Socket

249-1826-000/MIL-C-39029/51
 Size 12/RG-179B/U Cable (used in 71C15 layout)

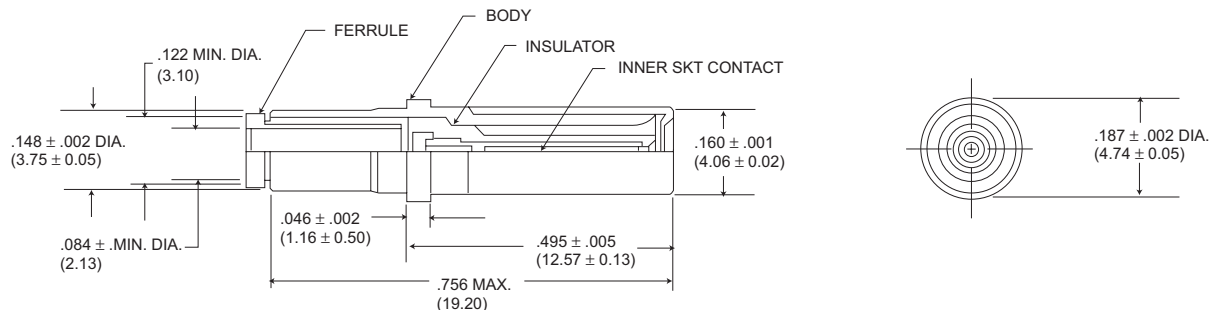

Pin

249-1826-000/MIL-C-39029/50
 Size 12/RG-179B/U Cable (used in 71C15 layout)

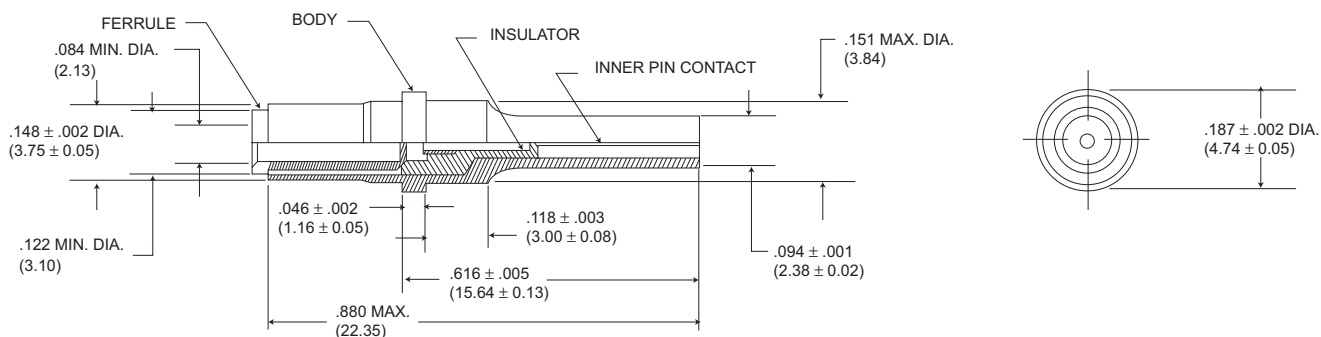

Assembly Instructions

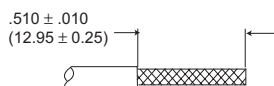

Step 1.
 Strip outer jacket to dimensions shown to expose outer conductor.

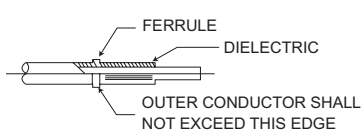

Step 2.
 Slip (or install) ferrule over outer conductor against cable jacket. Exposed portion of the outer conductor must be combed out then folded back over ferrule.

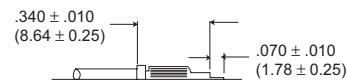

Step 3.
 Trim cable to dimensions, as shown. (Ferrule must butt against cable jacket).

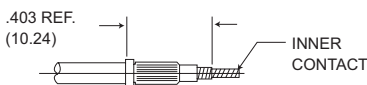

Step 4.
 Install inner contact against dielectric then crimp contact and center conductor with a M22520/2-01 crimp tool using a M22520/2-30 locator.

Step 5.
 Insert cable, ferrule and inner contact to rear of shell and crimp into place with M22520/5-03 crimp tool.



Coaxial Contact/Assembly

249-5500-010 Socket*
249-5500-011 PIN*

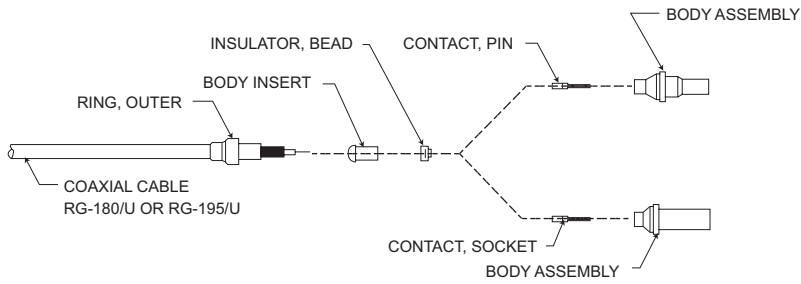

STEP 1.

Slide outer ring over cable as shown (Figure 1).

STEP 2.

Strip cable as shown (Figure 1).

STEP 3.

Install body insert, insulator bead, and contact on cable as shown (Figure 2).

STEP 4.

With body insert, insulator bead, and contact firmly in place, crimp the contact with tool M22520/2-01 (setting number 3) and locator M22520/2-30 (Figure 2). Caution: The assembled components must be tightly in place after crimping.

STEP 5.

Slide body assembly over components and under shield until firmly bottomed in place. Locate outer ring over shield and against body as shown (Figure 3).

STEP 6.

With cable and body assembly securely held together, hex crimp the outer ring with tool CCT-C9 (Figure 3). Important: For optimum hex crimp, firmly bottom the outer ring against the shoulder of the hex die before compressing the handles.

- NOTES:**
1. These assembly instructions apply to 249-5500-010, and 249-5500-011.
 2. The following assembly tools are required:
 - a) CCT-C9 hex crimp tool
 - b) MS3198-Q W/L-3198-C1 contact crimp tool and locator
 - c) 149 C(300 F) hot air gun (recommended): Regal heat Gun No. 9A)
 - d) Blades, scissors, and picks

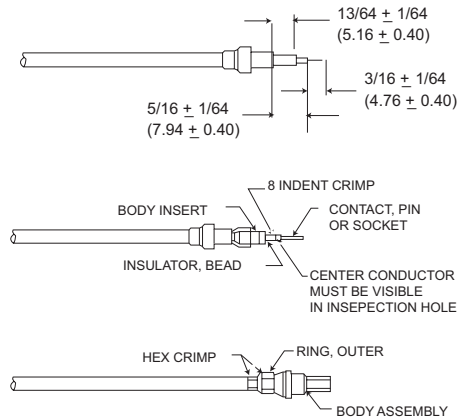

*These contacts are used in the F59C7 layout.

249-5500-012 Socket*
249-5500-013 PIN*

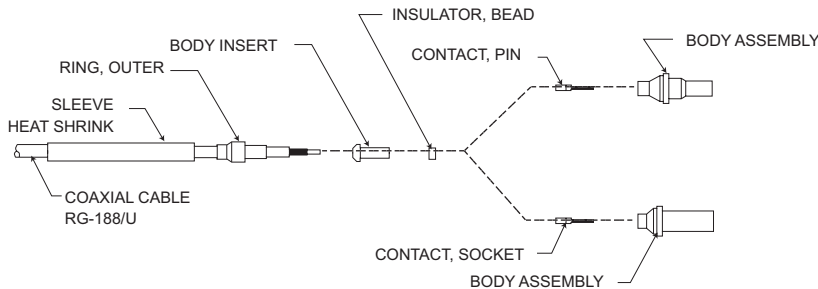

STEP 1.

Slide heat-shrink sleeve and outer ring over cable as shown.

STEP 2.

Strip cable as shown (Figure 1). Caution: Do not nick shield wires.

STEP 3.

Install body insert, insulator bead, and contact on cable as shown.

STEP 4.

With body insert, insulator bead, and contact firmly in place, crimp the contact with tool M22520/2-01, using setting number 3 and locator M22520/2-30 (Figure 2). Caution: The assembled components must be tightly in place after crimping.

STEP 5.

Slide body assembly over components and under shield until firmly bottomed in place. Locate outer ring over shield and against body as shown (Figure 3).

STEP 6.

With cable and body assembly securely held together, hex crimp the outer ring with tool CCT-C9 (Figure 3). Important: For optimum hex crimp, firmly bottom the outer ring against the shoulder of the hex die before compressing the handles.

STEP 7.

The final step is to shrink the heat sleeve in place with a hot air source of 149 C to 327 C (300 F to 621 F) (Figure 3).

- NOTES:**
1. These assembly instructions apply to 249-5500-010, and 249-5500-011.
 2. The following assembly tools are required:
 - a) CCT-C9 hex crimp tool
 - b) M22520/2-01 contact crimp tool and locator
 - c) 149 C(300 F) hot air gun (recommended): Regal heat Gun No. 9A)
 - d) Blades, scissors, and picks

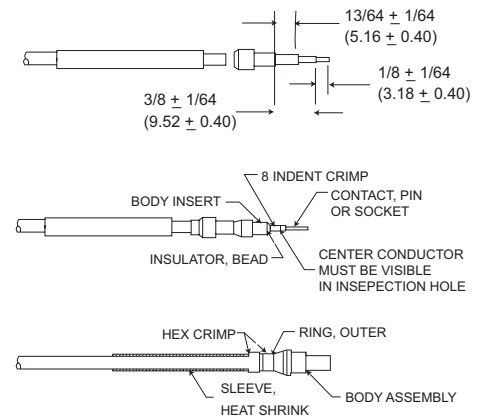

*These contacts are used in the G59C7 layout.

Dimensions shown in inch (mm)
Specifications and dimensions subject to change

www.ittcannon.com





DPA-Miniature Rack/Panel

DPA plugs are rugged, miniature rack/panel plugs utilizing maximum insert space in a one-piece shell. Polarization is accomplished with a keystone cornered shell and the coupling means is friction. Operating temperature for the DPA is - 55 C to + 125 C (-67 F to + 257 F)

DPAF - Float Mount Shells

DPAF plugs are DPA plugs with four rivets with washers on the contact termination side of the connector. Floating rivets are .093 (2.36) I.D. with a minimum of .032 (0.81) float.

DPAL - Large Flange Shells

DPAL plugs are DPA plugs with a large flange.

DPAMA - Little CAESAR' Contact Assembly

DPAMA plugs are DPA plugs with the proven LITTLE CAESAR contact assembly for rear insertion, release and extraction of crimp type contacts. Insertion requires no tool; extraction requires an expendable plastic tool. Hard dielectric, closed-entry socket insert has lead-in chamfers for positive mating of pin contacts. Contacts are of simpler, stronger design for greater resistance to bending or damage and are crimpable with the M22520/1-01 tool.

Material Specifications

		DPA/DPAF/DPAL	DPAMA
Shell	Material	Aluminum alloy	Aluminum alloy
	Finish	Cadmium plate with yellow chromate	Cadmium plate with yellow chromate
Insulator	Material	Melamine	Diallyl phthalate
	Material	Copper alloy	Copper alloy
Contacts	Finish	Gold over copper alloy	Gold over copper alloy
	Termination	Solder pot	Crimp

How to Order

DPA - 24C2 - 34 P
 DPA - 32 - 34 P -
 DPA R MA - 32 - 33 S - *

SERIES PREFIX _____

RoHS _____

CLASS _____

CONTACT ARRANGEMENT _____

SHELL TYPE _____

CONTACT TYPE _____

MOUNTING HOLE STYLE _____

MODIFIER _____

RoHS version

R - RoHS compatible

CLASS

F - Float mount shell

L - Large flange shell

MA - LITTLE CAESAR contact assembly with crimp, snap in contacts

CONTACT ARRANGEMENT

SHELL TYPE

33 for plug, 34 for receptacle

CONTACT TYPE

P - Pin

S - Socket

MOUNTING HOLE STYLES

DPA

No Dash - .093 (2.36) Dia.
 A - .093 (2.36) Dia., countersunk 82 to .173 (4.39) Dia.
 B - .120 (3.05) Dia., countersunk 100 to .225 (5.72) Dia.
 C - .093 (2.36) Dia., countersunk 100 to .182 (4.62) Dia.
 E - .120 (3.05) Dia.
 F - .100 (2.54) Dia.
 G - .120 (3.05) Dia., countersunk 82 to .203 (5.16) Dia.
 H - Tapped #4-40 NC-2
 J - .093 (2.36) Dia., countersunk 100 to .192 (4.88) Dia.

DPAMA

No Dash - .093 (2.36) Dia., countersunk 82 to .173 (4.39) Dia.
 A - .093 (2.36) Dia.
 B - .120 (3.05) Dia., countersunk 100 to .225 (5.72) Dia.
 C - .093 (2.36) Dia., countersunk 100 to .182 (4.62) Dia.
 D - .136 (3.45) Dia.
 E - .120 (3.05) Dia.
 F - .100 (2.54) Dia.
 G - .120 (3.05) Dia., countersunk 82 to .203 (5.16) Dia.
 H - Tapped #4-40 NC-2

MODIFIER

Add FO to order connector less contacts. Consult factory for other modifications.

Arrangements with coax contacts, such as 24C2, may be ordered without coax contacts by substituting a "W" for teh "C" e.g., DPA-24C2-34P with two coax contacts becomes DPA-24W2-34P with two cavities. The customer can then order separately any snap in coax contact shown on page 99. The customer is thus able to "create" arrangements with infinite combinations of coax contacts.

Dimensions shown in inch (mm)
 Specifications and dimensions subject to change



Solid Shell

DPA-33

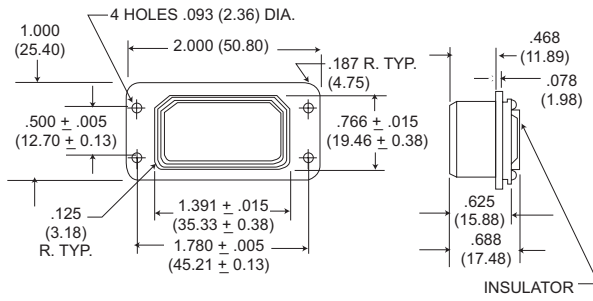

DPA-34

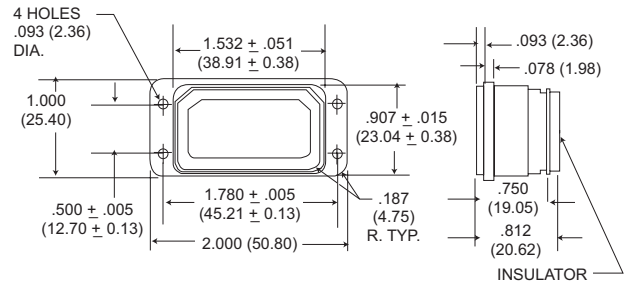

Large Flange Shell

DPAL-33

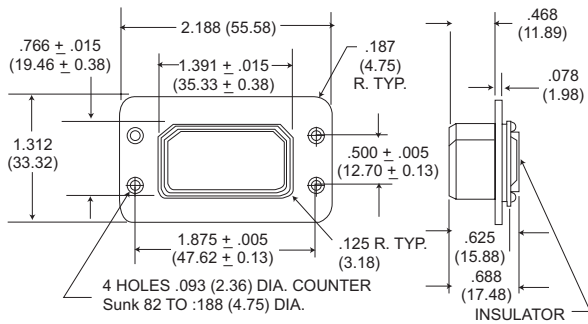

DPAL-34

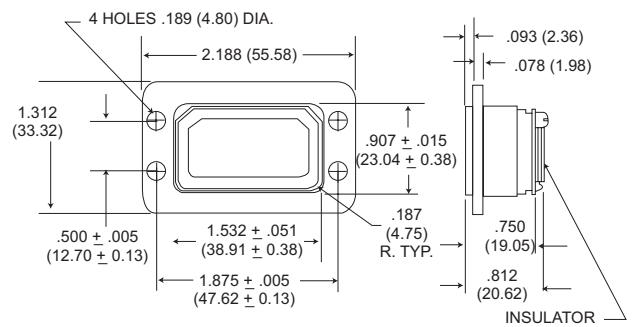

Float Mount Shell

DPAF-33

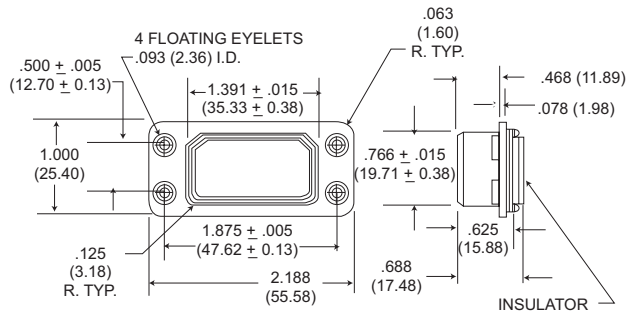

DPAF-34

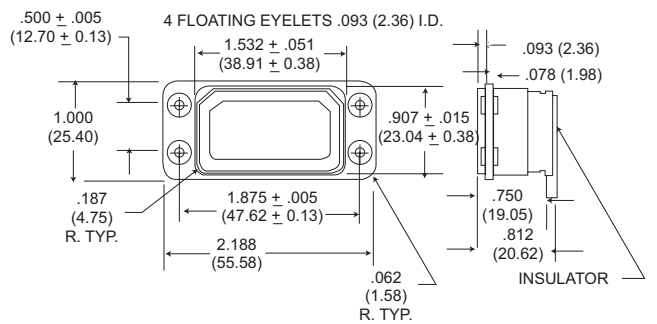

Contact Arrangements

Face view of pin insert

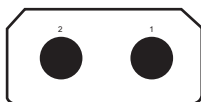

2
2 #4
2900

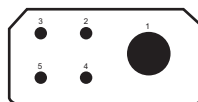

5
1 #4, 4 #14
2500

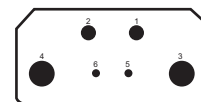

6
2 #8, 2 #12, 2 #20
2600 (5,6)

No. of contacts & Wire Size
Test Voltage AC (RMS)

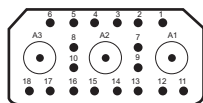

21C3
18 #20, 3 coax
1500 (1-18)
1000 (A1, A2, A3)

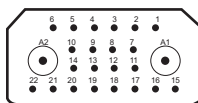

24C2
22 #20, 2 coax
1500 (1-22)
1000 (A1, A2)

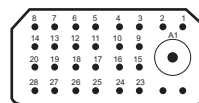

29C1
28 #20, 1 coax
1500 (1-28), 1000 (A1)

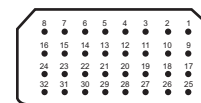

32
32 #20
1500

No. of contacts & Wire Size
Test Voltage AC (RMS)

Arrangement also available with LITTLE CAESAR contact assembly and may be employed in any shell type.

DPA Coaxial Variations

Termination Code	Variations of Basic Arrangements			Coaxial Type/Part Number	Max. Coaxial Extension From Rear of Flange	
					34 Shell	33 Shell
1	A21C3	*24C2	*29C1	FIXED	.953 (24.21)	.453 (11.51)
2	*21C3	D24C2	A29C1	FIXED	.859 (21.82)	.359 (9.12)
3*	B21C3	L24C2	C29C1	P-249-5012-000 S-249-5008-000	1.031 (26.91)	.500 (12.70)
4	C21C3	P24C2	F29C1	FIXED	1.094 (27.79)	.594 (15.09)
5	D21C3	K24C2	K29C1	FIXED	1.047 (26.59)	.561 (14.28)
6*	E21C3	N24C2	L29C1	P-249-5052-002 S-249-5051-001	1.218 (30.94)	.670 (17.02)
7	F21C3	B24C2	M29C1	FIXED	1.094 (27.79)	.594 (15.09)
8	F21C3	C24C2	N29C1	FIXED	1.094 (27.79)	.609 (15.47)
9	H21C3	R24C2	P29C1	FIXED	1.125 (28.98)	.625 (15.88)
10	21HV3	24HV2	29HV1	FIXED	1.062(26.98)	.554 (14.07)
11*	J21C3	H24C2	G29C1	P-249-5052-002 S-249-5051-001	1.218 (30.94)	.670 (17.02)
	21W3	24W2	29W1		Coaxials Not Supplied	

*Termination codes - 3, - 6, - 11 utilize snap - in nonremovable coaxials which are supplied with the connector. These coaxials may be ordered separately when ordering the connectors without coaxials (21W3 24W2 and 29W1 layouts).

DPAMA Coaxial Variations

Variations of Basic Arrangements		Coaxial Type/Part Number	Max. Coaxial Extension From Rear of Flange	
			34 Shell	33 Shell
24W2	29W1	Coaxials Not Supplies*	-	-
E24C2	B29C1	Crimp Type for RG-58/U cable	1.239 (31.47)	.737 (18.72)

*DPAMA coaxials purchased separately may be ordered under the following part numbers: Pin (Plug): 249-1741-000
Socket (receptacle): 249-9008-000
Crimp Tool: CA58073-0000
Extraction tool: CET-C11

NOTE: DPA snap in coaxials and DPAMA crimp coaxials are NOT interchangeable but are intermateable.

Contact Terminations

All dimensions are $\pm .010$ (0.25) unless indicated otherwise.

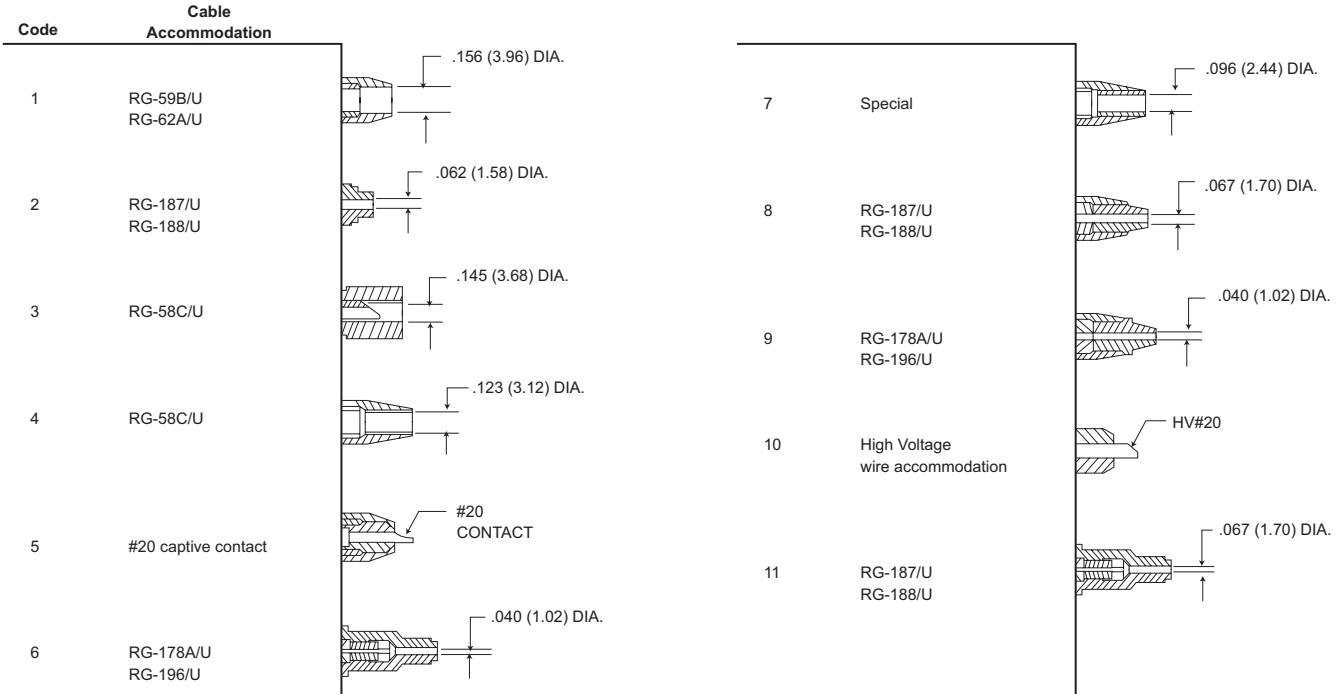

MAX. CONTACT EXTENSION from rear of insulator

Contact Size		20	18	14	12	8	4
Contact	Pin	.156 (3.96)	.140 (3.56)	.125 (3.18)	.218 (5.54)	.218 (5.54)	.250 (6.35)
Extension	Socket	.156 (3.96)	.250 (6.35)	.344 (8.74)	.218 (5.54)	.266 (6.76)	.531 (13.49)

Contact Arrangements

Dust Caps



DPA-59 FOR 33 SHELLS
025-0572-000



DPA-60 FOR 34 SHELLS
025-0573-000

Conductive: DPA-60-1
025-0573-001 (Protects
Against Static Electricity)

22054 Potting Shell

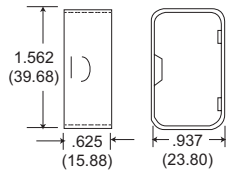

20746 Straight Junction Shell

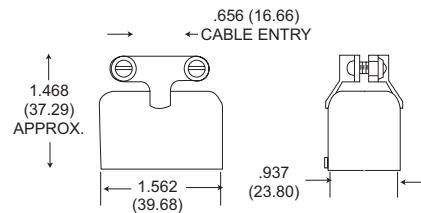

20746-1 90° Angle Junction Shell

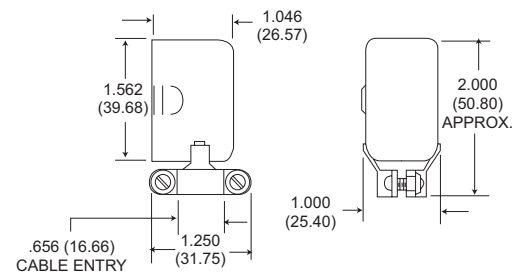

Dimensions shown in inch (mm)
Specifications and dimensions subject to change

www.ittcannon.com



DPGM/DPJM/DPJMB

Environmental, Rectangular Connectors for Aircraft, Missile and Ground Support Equipment Applications

Cannon's DPGM, DPJM, and DPJMB connectors are designed for applications where space and weight are prime considerations. Their rectangular shape provides maximum space utilization and permits easy removal of equipment for inspection and/or repair. DPGM and DPJM connectors feature crimp snap-in contacts with ring-type retention while DPJMB connectors feature the LITTLE CAESAR® rear release contact retention assembly (rear insertion, release and extraction of crimp snap-in contacts). They both have one piece diallyl phthalate insulators with polychloroprene wire sealing grommets. They also incorporate a peripheral seal design that allows an axial tolerance of up to .125 (3.175) while still effecting a seal. The 34 shell utilizes a rubber seal encased in such a way that the step down design of the mating 33 shell seats into and against it.

All of these connectors utilize keystone corners for polarization and are coupled by friction. Two shell styles with different mounting provisions are available.



For all new applications, the referenced connectors will be available only with insulators in the normal position, that is, pin insulators in the 34 (receptacle) shells and socket insulators in the 33 (plug) shells.

For replacements it is suggested that where practical, customers using these connectors with reversed insulators change to connectors with insulators in the normal position. However, for those who are unable to change we will furnish connectors with reversed insulators to maintain their equipment usage.

Standard Data

		DPGM/DPJM/DPJMB
Shell	Material	Aluminum alloy
	Finish	Cadmium plate with olive drab irridite
Insulator	Material	Diallyl phthalate
	Material	Copper alloy
Contacts	Finish	Gold plate
	Termination	Crimp
	No. of Contacts	8, 12, 15, 16, 20, 21, 32, 59, 98
Contact Arrangements		

How To Order

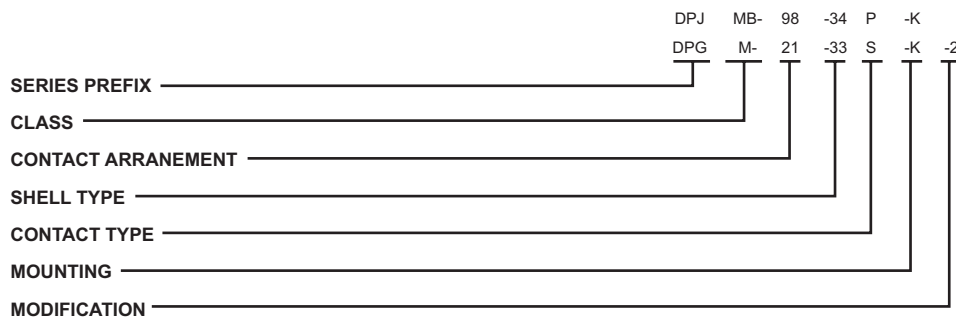

Contacts, coaxials and junction shells must be ordered separately, except for the DPJMB where the contacts are supplied with the connector. When (ordering or reordering) please specify the 3-4-3 contact part number as shown. We have cross-referenced these new part numbers with the previous part numbers (which have been obsoleted) for your convenience.

Example:

031-0900-001 new "3-4-3" part number
 (038819-001) previous part number

SERIES PREFIX

DPG, DPJ

CLASS

M - One piece insulator
 ring - type retention
 MB - LITTLE CAESAR contact retention assembly

CONTACT ARRANGEMENTS

DPGM - C8, 12, 15, 16, 20C4, 21 and 32
 DPJM - C21, 59, 59C10, and 98
 DPJMB - 59, 98

SHELL TYPE

33 for plug, 34 for receptacle

CONTACT TYPE

P for pin, S for socket

MOUNTING

33-K-With 6-32 clinch nuts
 33-B-Clearance holes for 6-32 screw
 34-K-Floating eyelet with 6-32 tapped I.D.
 34-B-Floating eyelet with .140 I.D.

MODIFICATION

-2-.125 (3.18) removed from front lip of -33 shell



Shell Dimensions - DPGM

33 SHELL

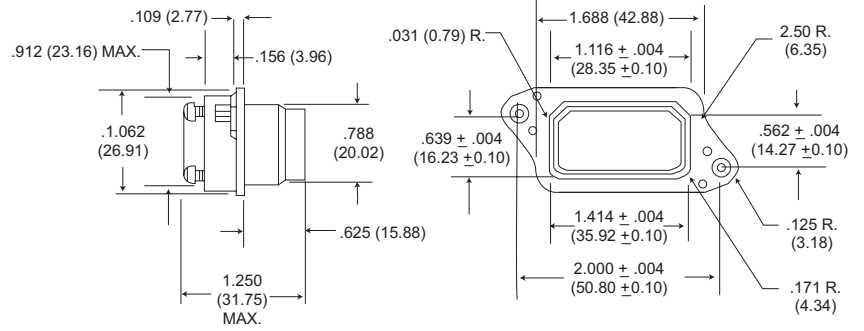

34 SHELL

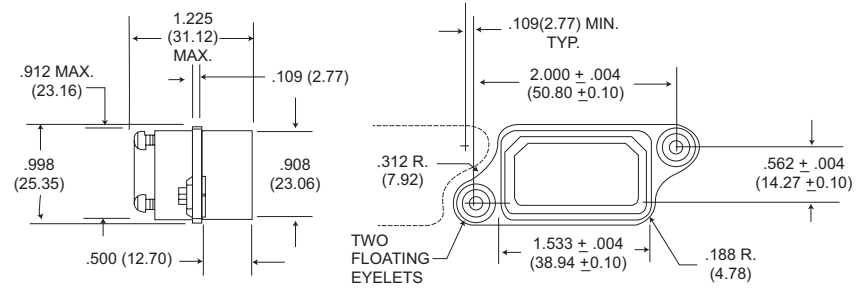

Shell Dimensions -DPJM/DPJMB

33 SHELL

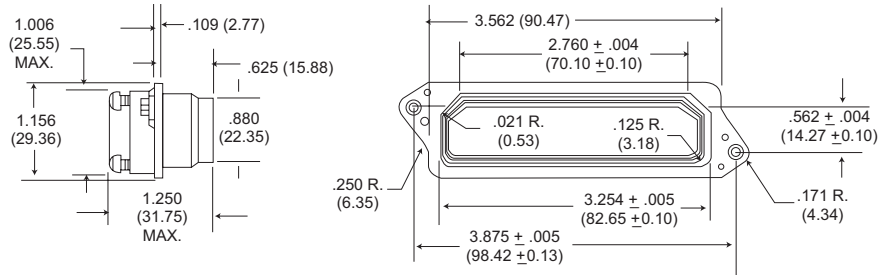

34 SHELL

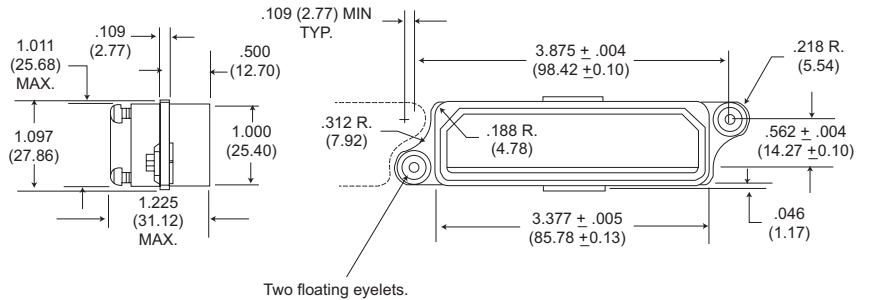

DPGM/DPJM/DPJMB

Contact Arrangements

DPGM

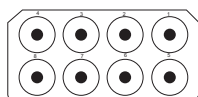

C8*
8 coax (1-8)
1000

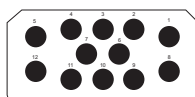

12*
12 #16 (1-12)
See note

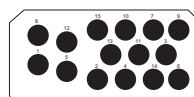

15*
15 #16 (1-15)
See note

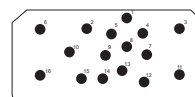

16*
5 #20 (3,6,10,11 & 16)
1500
9 #20 (1,4,5,7-9, 13-15)
1700
(2 #20 (2&12)
1500

No. of Contacts & Wire Size
Test Voltage AC (RMS)

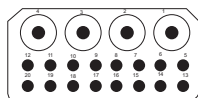

20C4*
16 #20 (5-20)
1500
4 COAX (1-4)
1000

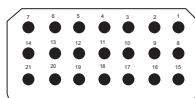

21*
21 #20 (1-21)
1500

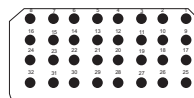

32*
32 #20 (1-32)
1500

No. of Contacts & Wire Size
Test Voltage AC (RMS)

*All DPGM arrangements have a 1500 VAC test voltage except for arrangements 12 and 15, which is 3200 VAC for contact 1,5,8 and 12. The remaining contacts have a 2200 VAC test voltage. All coaxials have 1000 VAC rms test voltage.

DPJM/DPJMB

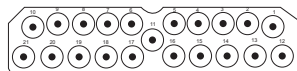

C21*
21 COAX (#1-21)
1000

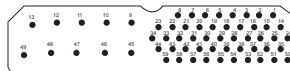

59
49 #20 (1-8,14-44 & 50-59)
1500
10 #12 (9-13 & 45-49)
1500

No. of Contacts & Wire Size
Test Voltage AC (RMS)

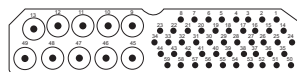

59C10*
49 #20 (1-8, 14-44&50-59)
1700
10 COAX (9-13&45-49)
1000

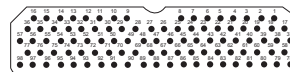

98*†
98 #20 (1-98)
1500

No. of Contacts & Wire Size
Test Voltage AC (RMS)

* All DPJM and DPJMB power contact arrangements have a 1500 VAC rms test voltage. Coaxials have 1000 VAC rms voltage.
†* Available with LITTLE CAESAR contact assembly (DPJMB).

Current Carrying Capacity of Wires and Cables	
Wire Size	Amperage
#4	80
#8	46
#12	23
#16	13
#20	7.5



Dimensions shown in inch (mm)
Specifications and dimensions subject to change

www.ittcannon.com

Junction Shells

DPGM

DPGM junction shells are essential for proper installation of connector and are ordered separately.

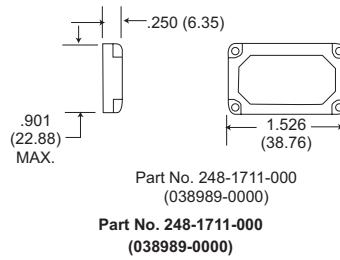

DPJM/DPJMB

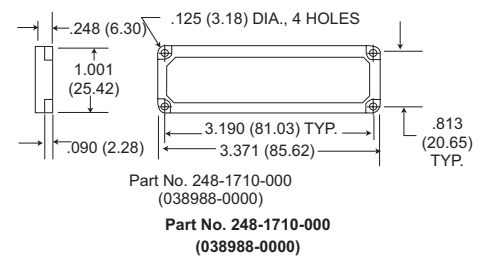

Wire Bushings

Small wires should be provided with rubber bushings before crimping. Approximately 1/16 (1.59) of an inch of bushing is visible when installed into grommet. Grommets will seal with out bushings or wire .096 (2.44) to .185 (4.70) to diameter.

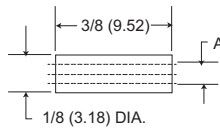

Sealing Wires on #12 and Coaxial Contacts

New Part Number	Existing Part Number	Wire Size O.D.	I.D A
012-0319-000	021604-0002	.040-.083	.062
012-0435-000	021604-0004	.080-.096	.080

Hole Fillers



All holes in grommet require filling either by a wire and contact, or by means of wire hole plugs.

Contact Size	Part Number
20	225-0070-000
16	225-0071-000
12	225-0072-000
Coaxial	225-0085-000

Contact/Coaxial Data and Termination Tool

DPJMB	Contact Size	Wire Size Accom.	Contact Part Number		Crimp Tool Part No.	Locator	Locator Color	Extraction Tool No.
			Pin	Socket				
	20	20-24	030-9081-001	031-9082-001	M22520/1-01	M22520/1-02	red	CET 20-14
	12	12-14	030-9185-002	031-9186-002	M22520/1-01	M22520/1-02	yellow	CET 12-4

DPGM/DPJM	Contact Size	Wire Size Accom.	Contact Part Number		Crimp Tool Part No.	Locator	Locator Color	Extraction Tool No.
			Pin	Socket				
	20	20-24	031-0905-000 (038820-0001)	031-0900-001 (038819-0001)	M22520/1-01	M22520/1-02	CIT 20	CET 20A
	16	16-20	031-0944-000 (040370-0000)	031-0945-000 (040371-0000)	M22520/1-01	M22520/1-02	CIT 16	CET 16
	12	12-14	031-0909-000 (038825-0000)	031-0908-000 (038826-0000)	M22520/1-01	M22520/1-02	CIT 12	CET 12
	20-18	18	031-0907-000 (038820-0000)	031-0906-000 (038819-0002)	M22520/1-01	M22520/1-02	CIT 18	CET 20A

Coaxials	Contact Size	Wire Size Accom.	Contact Part Number		Crimp Tool Part No.	Insertion Tool No.	Extraction Tool No.
			Plug	Receipt			
COAX	50 ohm (RG 196/U)		249-1178-001 (038834-0001)	249-1177-001 (038833-0001)	M22520/5-01 with Y-193 Die	CIT C2	CET C1
COAX	75 ohm (RG 1871U)		249-1176-001 (038832-0001)	249-1175-001 (038831-0001)	WT400 995-001-071	CIT C2	CET C1
COAX	95 ohm (RG 195/U)		249-1174-001 (038830-0001)	249-1173-001 (038829-0001)	WT402 HX3-138	CIT C2	CET C1
COAX	150 ohm		249-1172-001 (038828-0001)	249-1171-001 (038827-0001)	WT408	CIT C2	CET C1

Dimensions shown in inch (mm)
Specifications and dimensions subject to change



Assembly Procedures

Wiring and Crimping Contacts

Wires should be stripped to the dimension appropriate to the contact use

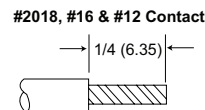
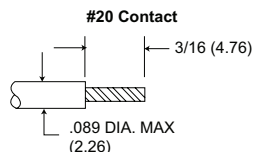

1. CONTACT INTO CRIMP TOOL

Drop contact into crimp tool, it will locate on the contact shoulder.

2. WIRE INTO CONTACT

Take wire stripped to dimensions above, and push into the contact crimp pot until it is completely home.

Where outside diameter of wire in the #12 or COAXIAL contact is less than .096 (2.44), a rubber bushing must be slipped over the wire before crimping (see page 103).

3. CRIMP

Squeeze the crimp tool to secure the wire into the contact. It is not possible to remove the contact from the crimp tool until crimp is completed.

4. REMOVED WIRED CONTACT FROM TOOL

5. INSPECT

If wires are stripped and crimped correctly, the wire will be visible through the small inspection hole in the contact.

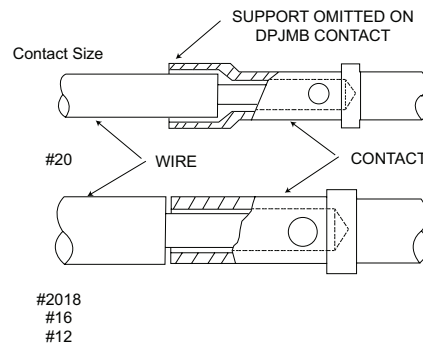

Contact Insertion (DPGM/DPJM)

Inserting #20 & #16 Contacts

Inserting Coaxial & #12 Contacts



After the contacts have been crimped, they should be threaded through the junction shell and inserted with the tools shown below. It is recommended that the contacts be inserted in the center horizontal row first, then work to the top and bottom horizontal rows.

Contact	Tool Description	Assembly Number
#20	CIT - 20	038894-0000
#16	CIT - 16	038895-0000
#12	CIT - 12	038896-0000
Coaxial 50-75,95 & 150 ohm	CIT - C2	038901-0000

Contact Extraction (DPGM/DPJM)

Extracting #20 & #16 Contacts

Extracting Coaxial & #12 Contacts



If it is necessary at any time to remove contacts, this may be accomplished with an impact extraction tool. Simply place the correct tool on the engaging end of the contact and push. A reversible tip is provided for pins and sockets.

Contact	Tool Description	Assembly Number
#20	CET - 20A	038889-0100
#16	CET - 16	038888-0000
#12	CET - 12	038890-0000
Coaxial 50-75,95 & 150 ohm	CET - C1	038869-0000

Assembly Procedures

Coaxial Contact Assembly (DPGM/DPJM)

Cable Stripping



	Cable Trim Dimensions			Cable Entry Dimensions		
	A	B	C	D min. dia.	E max. dia.	F min. dia.
150 ohm	3/16 (4.76)	1/16 (1.59)	5/32 (3.97)	.154 (3.91)	.183 (4.65)	.202 (5.13)
95 ohm	3/16 (4.76)	1/8 (3.18)	5/64 (1.98)	.106 (2.69)	.139 (3.53)	.153 (3.89)
75 ohm	3/16 (4.76)	1/8 (3.18)	5/64 (1.98)	.122 (3.10)	.158 (4.01)	
50 ohm	1/4 (6.35)	1/8 (3.18)	5/64 (1.98)	.106 (2.69)	.136 (3.53)	

50 Ohm Contact (RG-196U)
(assembly steps 1, 2, 3, 4, 5 & 8)

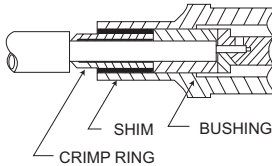

75 Ohm Contact (RG-187U)
(assembly steps 1, 2, 3, 5 & 8)

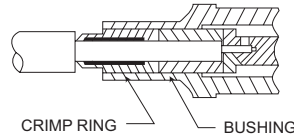

95 Ohm Contact (RG-195U)
(assembly steps 1, 3, 6, 7 & 8)

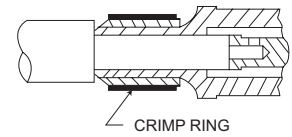

Assembly Steps

1. After the coaxial cable has been stripped to the proper dimensions, tin the center conductor. If O.D. of cable is less than .096 (2.44), slip rubber bushing over wire. (50, 75 & 95 ohm)
2. Assemble crimp ring under braid and add bushing to cable. (50 & 75 ohm)

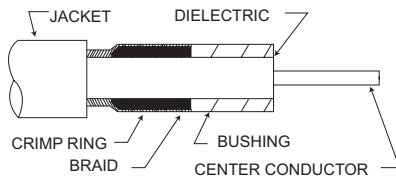

3. The center contact is supplied loose in the polyethylene bag. Insert the tinned conductor into the contact. Wire must be visible through inspection hole and dielectric pushed against contact shoulder. For 150 ohm contact shoulder must be flush against bushing. Heat contact with a clean soldering iron. Avoid solder outside contact. (50, 75, & 95 ohm)

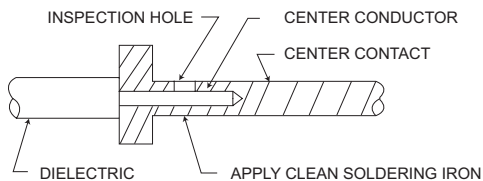

4. Wrap shim around braid. (50 ohm)

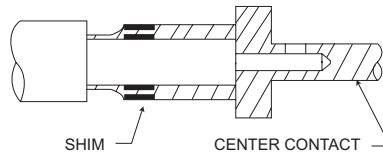

5. Feed cable and assembled parts into coaxial shell. Care is required if braid is to fit smoothly inside the shell. (50 & 75 ohm)
6. Thread crimp ring over cable. Feed center contact into coaxial shell with the shell between the dielectric and the braid. (95 ohm)

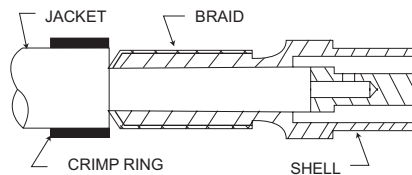

7. Slip crimp over the braid. (95 ohm)
8. Crimp - crimp tool must be located 1/16 (1.58) to 5/64 (1.98) from shoulder of coaxial. (50, 75 & 95 ohms)

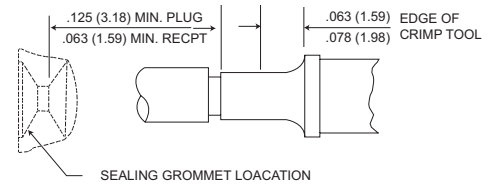

DPGM/DPJM/DPJMB

Junction Shell, Assembly of



Slip junction shell over grommet and secure with four screws and lock washers.

Panel Cutouts

33 and 34 Shell Styles

DPGM

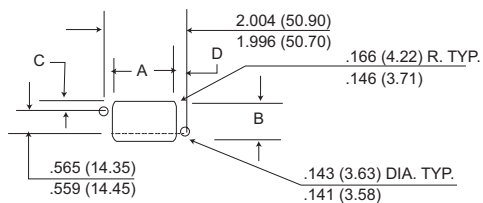

DPJM DPJMB

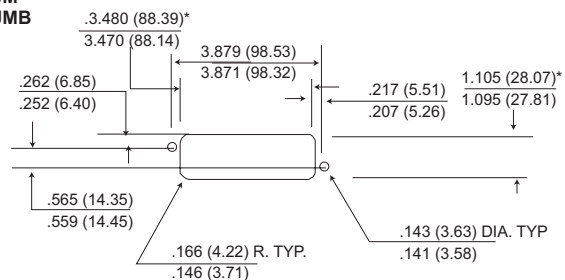

*These dimensions allow for float mounting.

	A	B	C	D	Gap Between Flanges after mating
DPGM-33	1.609(40.87)	.985(25.02)	.214(5.44)	.203(5.16)	.500(12.70) .625(15.88)
	1.599(40.61)	.975(24.76)	.204(5.18)	.193(4.90)	
DPG-34	1.636(41.55)	1.011(25.68)	.227(5.76)	.190(4.83)	.500(12.70) .625(15.88)
	1.626(41.30)	1.001(25.42)	.217(5.51)	.180(4.57)	

PANEL THICKNESS: Maximum sum of both panel thicknesses is 7/16 of an inch when 33 plug and 34 receptacle are back mounted. Shell style 33 modifications A and -2 can be back mounted ONLY. Shell style 33 modifications B and shell style 34 modifications B and H may be front or back mounted. Consult factory for additional information.

Mounting Variations

33 Shell



34 Shell

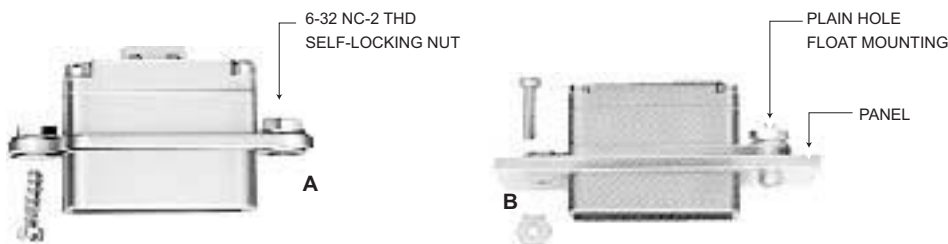

Dimensions shown in inch (mm)
Specifications and dimensions subject to change

www.ittcannon.com

- Rectangular Rack/Panel Connectors
- Non-Environmental Single and Two-Gang Configurations

Cannon's DPD Rack and Panel connectors are distinguished from other connector lines by their rectangular shape which provides maximum space utilization on a rack or chassis mounted equipment. The DPD is used in any commercial application where moisture/ environmental resistance is not required, such as I/O connector or computer panels, GFE test equipment, and GSE ground support equipment. For example, one-half of a connector assembly is mounted on a radio rack, or panel, and the mating connector is attached to a cable that

connects to another instrument or rack. The DPO has a temperature range of -55°C to +125°C (-67°F to +257°F). In addition to standard DPD connectors with solder contacts, the DPDMA version has rear insertion, rear release crimp, snap-in contacts that feature the LITTLE CAESAR®, rear. release contact retention assembly used in many other ITT product lines.



DPD-33/DPDMA-33
Plug



DPD-34/DPDMA-34
Receptacle



DPD2-33/DPD2MA-33
Plug



DPD2-34/DPD2MA-34
Receptacle

DPD - Standard Rack and Panel Connector Series

DPD connectors are the original rectangular rack and panel connectors with solder type contact termination, accommodating a wide range of contact arrangements and a variety of endbells and junction shells.

DPDMA - LITTLE CAESAR® Contact Assembly

DPDMA connectors are DPD's with the LITTLE CAESAR contact assembly for rear insertion, release and extraction of crimp type contacts. Contacts are inserted by hand, and extraction is accomplished with the use of an expendable plastic

tool. Hard dielectric, closed-entry socket inserts have lead-in chamfers for positive mating of pin contacts during engagement. Both the DPD and DPDMA connectors are intermateable.

DPD2 - Two Gang Version of DPD

DPD2 connectors are two-gang versions of the DPD solder type connectors designed to handle double the circuitry in instrument panel disconnect applications. The DPD2 is identical in shell style and materials to the DPD, but features a center coupling screw for positive engagement. Various coupling devices are shown on pages 114-115. The DPD2 may also be ordered without the engaging device by

omitting the letter code "M" as shown in the ordering nomenclature. Two optional polarizing posts give up to six alternate insert positions (page 112).

DPD2MA - LITTLE CAESAR® Contact Assembly

DPD2MA connectors are DPD2 connectors with the LITTLE CAESAR contact assembly for rear insertion, release and extraction of crimp type contacts. Contact insertion is by hand and extraction is by an expendable plastic tool. Hard dielectric, closed-entry socket inserts have lead-in chamfers for positive mating of pin contacts during engagement. DPD2 and DPD2MA connectors are intermateable.

Performance and Material Specifications

MATERIALS AND FINISHES

		DPD/DPD2	DPDMA/DPD2MA	DPD/DPDMA Specifications
Shell/Polarization Hardware	Material	Aluminum alloy	Aluminum alloy	QQ-A-591/A380
	Finish	Natural cadmium plate	Natural cadmium plate	QQ-P-416
Insulator	Material	Melamine or fabricated phenolic	Diallyl phthalate	MIL-M-14
	Material	Copper alloy	Copper alloy	QQ-C-533
Contacts	Finish	Silver or gold plate*	Silver or gold plate*	QQ-C-365 MIL-G-45204
	Termination	Solder pot	Crimp	N/A

*Size 20 contacts have gold plate finish. All other sizes have silver plate finish. Tin alloy may be substituted for silver.

VOLTAGE/CURRENT DATA

Insert Voltages/Test Results

There was no evidence of breakdown when the test voltages given were applied, for a period of one minute, between the contacts and between the shell and the contacts with spacings as noted.

Laboratory Conditions

Ambient Temperature	23°C to 27°C (73°F to 80.6°F)
Relative Humidity	69% to 73%
Barometric Pressure	29.70 (754.38) to 29.75 (755.65)

Current Carrying Capacity of Wire and Cables

Wire Size	#4	#6	#8	#10	#14	#16	#20
Amperage	100	80	60	35	25	20	7.5

Contact Clearance	Test Voltage 60 cps (ac rms)	Contact Clearance	Test Voltage 60 cps (ac rms)
1/64 (0.40)	540 Volts	3/16 (4.76)	3650 Volts
1/32 (0.79)	1000 Volts	13/64 (5.16)	3850 Volts
3/64 (1.19)	1300 Volts	7/32 (5.56)	4050 Volts
1/16 (0.59)	1700 Volts	15/64 (5.95)	4240 Volts
5/64 (1.98)	2050 Volts	1/4 (6.35)	4420 Volts
3/32 (2.38)	2350 Volts	19/64 (7.54)	4940 Volts
7/64 (2.78)	2600 Volts	5/16 (7.94)	5100 Volts
1/8 (3.18)	2900 Volts	3/8 (9.52)	5750 Volts
9/64 (3.57)	3050 Volts	25/64 (9.92)	5890 Volts
5/32 (3.97)	3250 Volts	13/32 (110.32)	6020 Volts
11/64 (4.37)	3450 Volts	7/16 (11.11)	6300 Volts
		1/2 (12.70)	6800 Volts

Dimensions shown in inch (mm)

Specifications and dimensions subject to change

www.ittcannon.com



How to Order

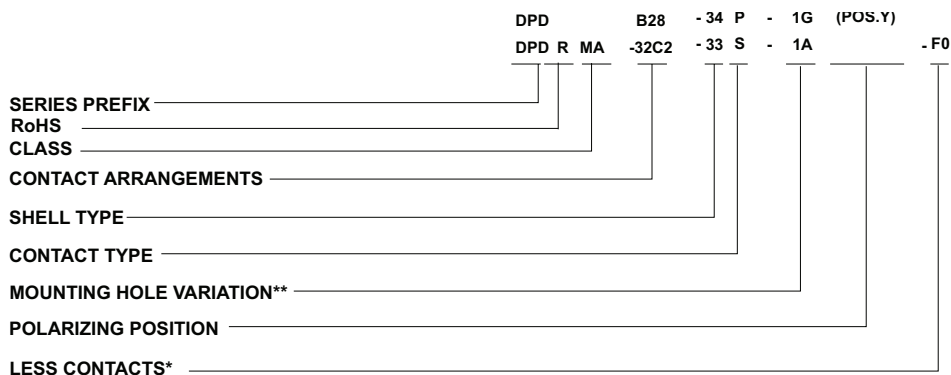

SERIES PREFIX

DPD - ITT Prefix

CLASS

Blank - Solder contacts
 MA - Crimp type contacts in LITTLE CAESAR contact assembly

CONTACT ARRANGEMENTS

See page 106 (solder termination), Page 111 (crimp termination)

SHELL TYPE

33 for plug, 34 for receptacle

CONTACT TYPE

P - Pin
 S - Socket

MOUNTING HOLE VARIATION

1A - .144 (3.66) dia., for #6 flathead screw
 1B - .144 (3.66) dia., 100° countersunk for #6 flathead screw
 1G - .152 (3.86) dia., 82° C countersunk for #6 flathead screw
 1L - .144 (3.66) dia., 82° countersunk for #6 flathead screw

POLARIZING POSITION

N,V,W,X,Y,Z (See page 116)

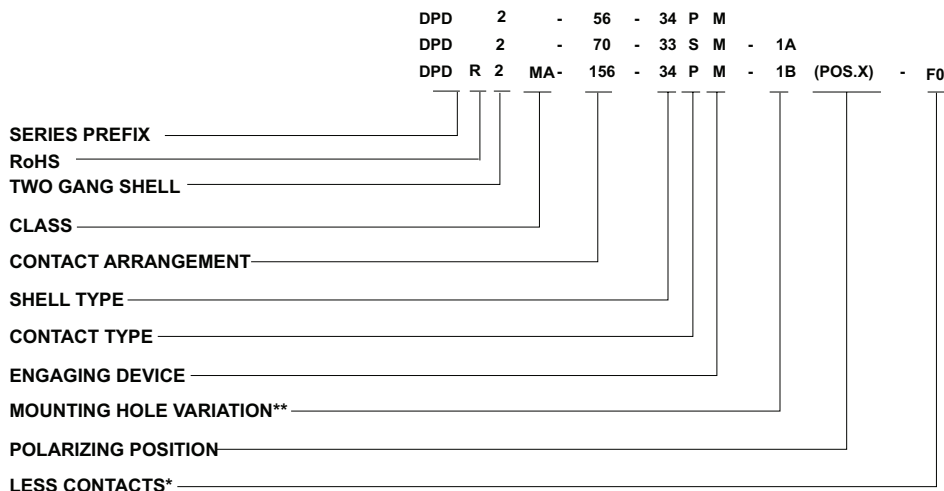

SERIES PREFIX

DPD - ITT Prefix

RoHS version

R - RoHS compatible

TWO-GANG SHELL

2 - Two-gang shell

CLASS

Blank - Solder contacts
 MA - Crimp type contacts in LITTLE CAESAR contact assembly

CONTACT ARRANGEMENTS

See page 110 (solder termination), page 1110 (crimp termination)

SHELL TYPE

33 for plug, 34 for receptacle

CONTACT TYPE

P - Pin
 S - Socket

ENGAGING DEVICE

For devices available, see pages 114-115

MOUNTING HOLE VARIATION**

1A - .144 (3.66) dia., for #6 cap screw
 1B - .144 (3.66) dia., 100° countersunk for #6 flathead screw
 1G - .152 (3.86) dia., 82° C conutersunk for #6 flathead screw

POLARIZING POSITION

N,V,W,X,Y,Z (See page 116)

36) dia. mounting hole 82° countersunk for #6 flathead screw.



Single Gang

33 Plug

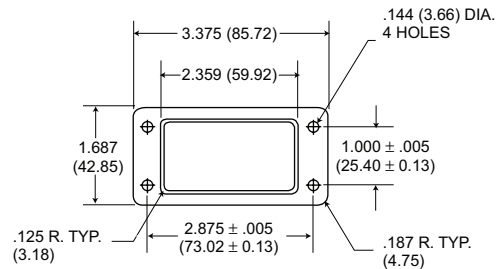
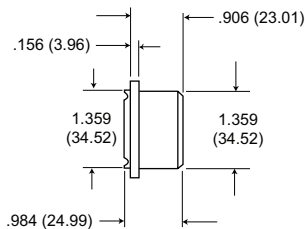

For mounting hole variations, see page 108

33 Receptacle

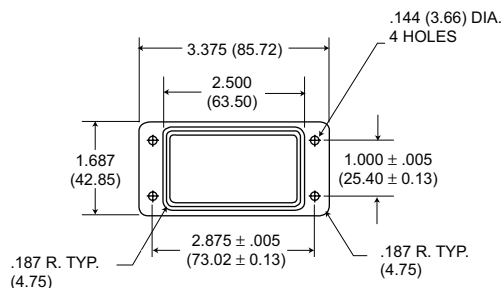
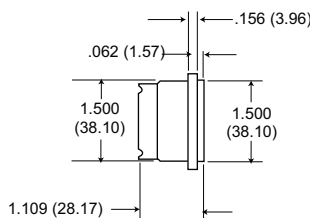

For mounting hole variations, see page 108

Two Gang

33 Plug

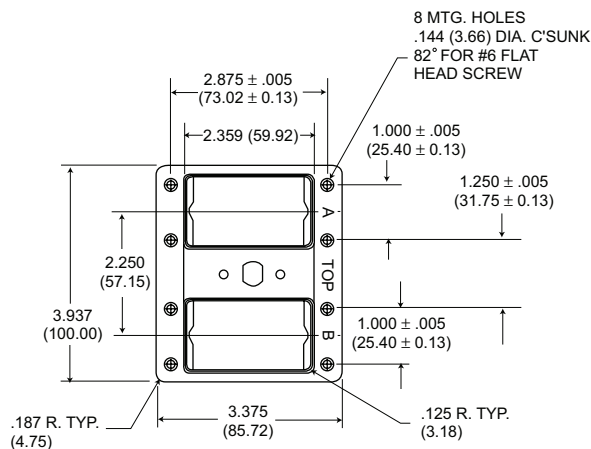
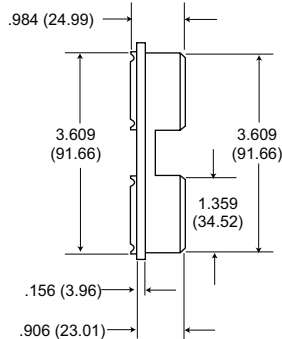

For headscrew variations, see page 115

34 Receptacle

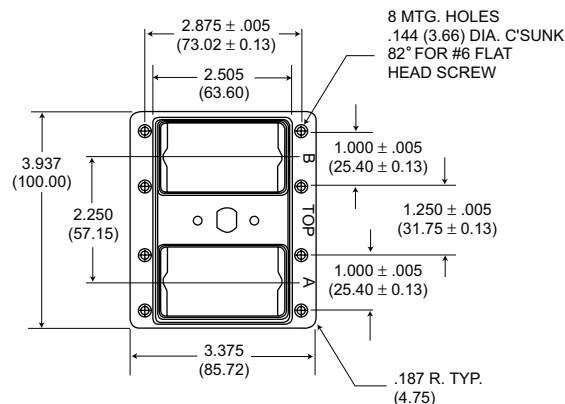
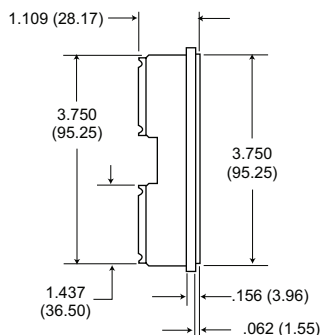

For headscrew variations, see page 115

Contact Arrangements - DPD Solder

Face view of pin insert
Illustrations are not actual size

See page 107 for test voltage

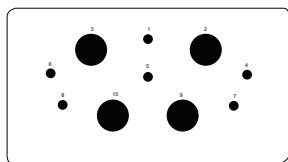

MOLDED N10
TOTAL CONTACTS:10
2-#16(#1,5) CLEARANCE 5/32 (3.97)
4-#16(#4,6,7,8,) 9/64 (3.57)
4-#4(#2,3,9,10) 9/64 (3.57)

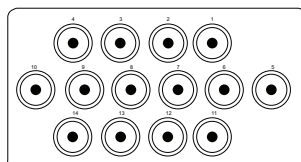

MOLDED AJ14 for crimp AN14 for solder
TOTAL CONTACTS:14
14 min. coax. (#1-14) CLEARANCE 1/16 (1.59)

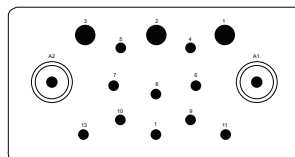

MOLDED 15C2
TOTAL CONTACTS:15
2-#14 (#4,5) CLEARANCE 3/16 (4.76)
2-#14 (#6,7) 7/32 (5.56)
2-#14 (#9,10) 1/4 (6.35)
1-#14 (#8) 9/32 (7.14)
3-#14 (#11-13) 13/64 (5.16)
3-#10 (#1-3) 11/64 (4.37)
2-coax. (A1,A2) grounded

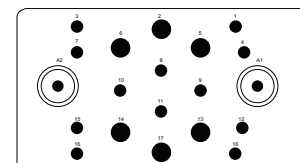

MOLDED B20C2
TOTAL CONTACTS:20
8-#16 (#1,3,4,7,12,15,16,18) CLEARANCE 3/64 (1.19)
2-#16 (#8,11) 11/64 (4.37)
2-#16 (#9,10) 5/32 (3.97)
6-#14 (#2,5,6,13,14,17) 5/32 (3.97)
2-coax. (A1,A2) grounded

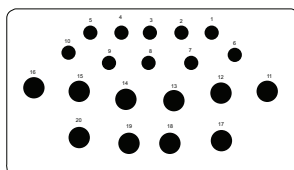

MOLDED G20
TOTAL CONTACTS:20
3-#14(#7,9) CLEARANCE 5/64 (1.98)
7-#14(#1-6,10) 1/16 (1.59)
2-#10(#18,19) 1/16 (1.59)
8-#8(#11-17,20) 1/16 (1.59)

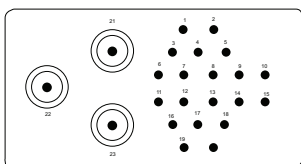

MOLDED 23C3
TOTAL CONTACTS:23
20-#16(#1-20) CLEARANCE 1/16 (1.59)
3-coax.(#21-23) grounded

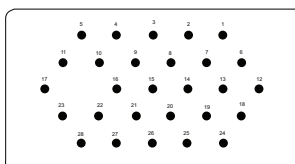

MOLDED B28
TOTAL CONTACTS:28
28-#16(#1-28) CLEARANCE 7/64 (2.78)

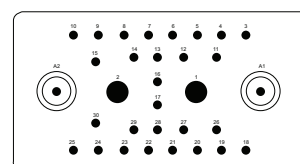

MOLDED 32C2
TOTAL CONTACTS:32
28-#16(#3-30) CLEARANCE 3/64 (1.19)
2-#8(#1,2) (.156 Dia.) 3/64 (1.19)
2-coax. (A1, A2) grounded

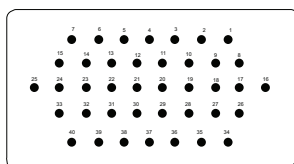

FABRICATED 40
TOTAL CONTACTS:40
40-#16(#1-40) CLEARANCE 1/16 (1.59)

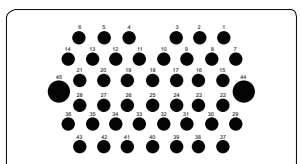

MOLDED 45
TOTAL CONTACTS:45
43-#16(#1-43) CLEARANCE 3/16 (1.19)
2-#10(#44, 45) 3/64 (1.19)

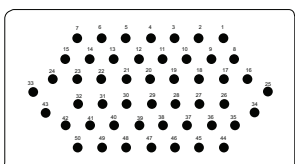

MOLDED 50
TOTAL CONTACTS:50
50-#16(#1-50) CLEARANCE 1/16 (1.59)

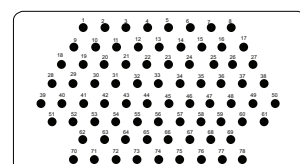

MOLDED 78
TOTAL CONTACTS:78
78-#16(#1-78) CLEARANCE 1/32 (0.79)

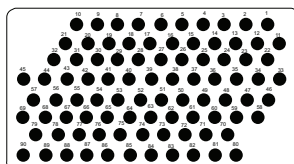

MOLDED 90
TOTAL CONTACTS:90
90-#16(#1-90) CLEARANCE 1/32 (0.79)

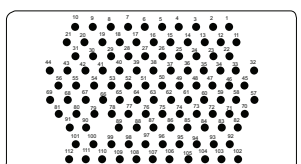

FABRICATED 112
TOTAL CONTACTS:112
112-#20(#1-112) CLEARANCE 3/64 (1.19)

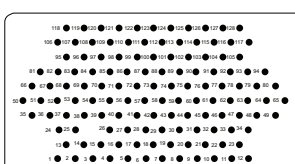

FABRICATED 128
TOTAL CONTACTS:128
128-#20(#1-128) CLEARANCE 3/64 (1.19)

Contact Arrangements - DPDMA Crimp

Face view of pin insert
Illustrations are not actual size

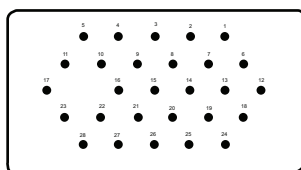

MOLDED B28
TOTAL CONTACTS:28
28-#16(#1-28) CLEARANCE 7/64 (2.78)

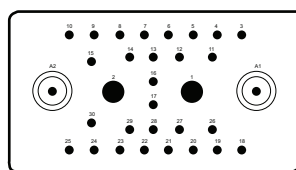

MOLDED 32C2*
TOTAL CONTACTS:32
28-#16(#3-30) CLEARANCE 3/64 (1.19)
2-#8(#1,2) (.156 Dia.) 3/64 (1.19)
2-coax. (A1, A2) grounded

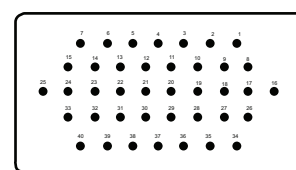

MOLDED 40
TOTAL CONTACTS:40
40-#16(#1-40) CLEARANCE 1/16 (1.59)

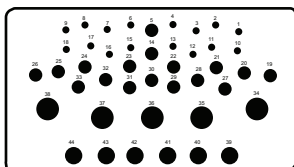

MOLDED A44
TOTAL CONTACTS:44
16-#20(1-4, 5-13, 15-18) CLEARANCE 3/64 (1.19)
17-#16(5,14,19-33) 3/64 (1.19)
6-#12(39-44) 3/64 (1.19)
5-#8(34-38)(.142 Dia.) 3/64 (1.19)

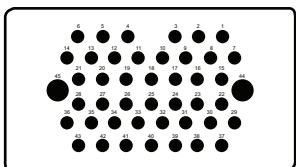

MOLDED 45
TOTAL CONTACTS:45
43-#16(#1-43) CLEARANCE 3/64 (1.19)
2-#10(#44, 45) 3/64 (1.19)

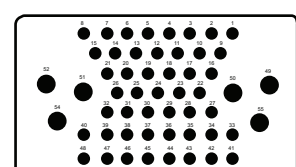

MOLDED F54
TOTAL CONTACTS:54
48-#16(#1-48) CLEARANCE 1/32 (0.79)
6-#12(49-54) 1/16 (1.59)

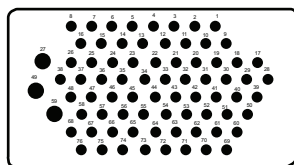

MOLDED 76
TOTAL CONTACTS:76
73-#20(1-26,28-48, 50-58,60-76) CLEARANCE 5/64 (1.98)
3-#16(27,49,59)

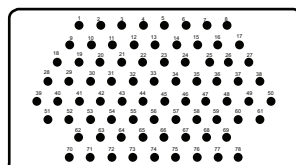

MOLDED 78
TOTAL CONTACTS:78
78-#16(#1-78) CLEARANCE 1/32 (0.79)

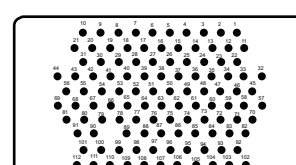

FABRICATED 112
TOTAL CONTACTS:112
112-#20(#1-112) CLEARANCE 3/64 (1.19)

*32C2 arrangement may be purchased less coaxial contacts as -30. All contact variations shown for 32C2 may be purchased in the DPDMA.

DPD2/DPD2MA

DPD2 Insert assemblies consist of two standard DPD insert mounted in a DPD2 shell. They are identified as insert "A" and insert "B". Any two inserts with similar contact arrangements can be used together.

The tabulation lists the DPD2 contact arrangement ordering number for the the combination of two inserts. For complete information on each insert, see page 113. Consult factory for combination layouts not shown.

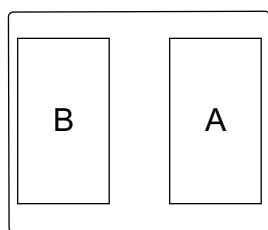

DPD2/DPD2MA Insert Designations (face view - 34 shell)

DPD2 Arr. No	Side A	Side B
N20	N10	N10
G48	G20	B28
B56	B28	B28
64	32	32
64C4	32C2	32C2
B68	40	B28
77	45	32
78	50	28
80	40	40
90	45	45
B98C2	B20C2	78
G98	78	G20

DPD2 Arr. No	Side A	Side B
H98C2	H20C2	78
100	50	50
A110	32	78
123	45	78
A123	78	45
152	76	76
156	78	78
180	90	90
190	78	112
224	112	112
256	128	128



Dimensions shown in inch (mm)
Specifications and dimensions subject to change

www.ittcannon.com

Contact Data

Coaxial

Type	Part Number	Description	Cable	Layout/Usage
Pin	249-0365-000	Plug, Straight		
Socket	249-0366-000	Receptacle, Straight	RG-7/U	
Pin	249-0399-000	Plug, Straight	RG-59/U	
Socket	249-0398-000	Receptacle, Straight	RG-62/U	
Pin	249-0409-000	Plug, 90° Short		15C2
Socket	249-0410-000	Receptacle, 90° Short	RG-58/U	B20C2
Pin	249-0228-000	Plug, 90° Long		23C2
Socket	249-0226-000	Receptacle, 90° Long		32C2
Pin	249-0229-000	Plug, 90° Short	RG-7/U	
Socket	249-0227-000	Receptacle, 90° Short		
Pin	249-1365-000	Plug, Solder		
Socket	249-1357-000	Receptacle, Solder	RG-195/U	
Pin	249-1333-000	Plug, Solder	RG-59/U	AN14
Socket	249-1332-000	Receptacle, Solder	RG-62/U	
Pin	249-1264-000	Plug, Crimp	RG-59/U	
Socket	249-1265-000	Receptacle, Crimp	RG-62/U	AJ14

Crimp

Contact Size	Type	Part Number	Wire Size	Max. Wire Insul O.D	Crimp Tool Part Number	Locator	Extraction Tool Part Number	Layout/Usage
20	Pin	030-9081-000	20-24	.084 (2.13)	M22520/1-01	M22520/1-02	CET 20-8	76, 112, A44
	Socket	031-9134-001						
16-20	Pin	030-9123-000	20-24	.084 (2.13)	M22520/1-01	Blue	CET 16-9 CET 16-15	B28, 32C2, 40, A44, F54, 45, 76, 78
	Socket	031-9203-002						
16	Pin	030-9083-000	16-20	.110 (2.79)	M22520/1-01	Blue	CET 16-9 CET 16-15	45, 76, 78
	Socket	031-9206-003						
12	Pin	030-1909-000	12-16	.150 (3.81)	M22520/1-01	Yellow	CET 12-4	A44, F54
	Socket	031-1059-000						
30A (#10)	Pin	030-1757-000	10-12	.206 (5.23)			CET 10-1	45
	Socket	030-1758-000						
40A (#8)	Pin	030-9175-000	8-10	.250 (6.35)		Solder Pot Type Only		32C2
	Socket	030-9176-000						
8	Pin	030-1908-000	8-10	.250 (6.35)	CBT-600B CCH-8-1 CCHP-8-6		CET 8-2	A44
	Socket	030-9201-003						

R Coaxial

R Coaxial Contact Rating
10 amps
Cable Size
RG-7/U .250 (6.35) I.D.
Test Voltage
1000 rms AC

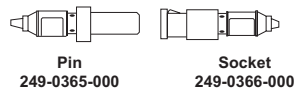

R Coaxial 90° (long) Contact Rating
10 amps
Cable Size
RG-7/U
Test Voltage
1000 rms AC

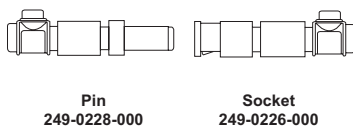

R Coaxial 90° (short) Contact Rating
10 amps
Cable Size
RG-7/U
Test Voltage
1000 rms AC

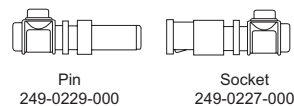

HV CONTACT Contact Rating
10 amps
Wire Size
#16
Test Voltage
7500 rms AC



Hi Voltage contacts fit the coaxial cavities. Must be disassembled in order to be soldered.

R COAXIAL

Contact Rating 10 amps

Coaxial Cable Size	X Cable Entry
RG-58/U	.127 (3.23)
RG-59/U	.157 (3.99)
RG-62/U	.157 (3.99)

Test Voltage 1000 rms AC

R COAXIAL ADAPTER

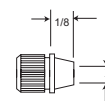

The adapter is shown for reference only. It is furnished part of the complete coaxial contact assy.

R Coaxial 90° (short)

Contact Rating 10 amps

Coaxial Cable Size
RG-58/U

Test Voltage 1300 rms AC

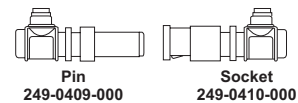

R COAXIAL ADAPTER

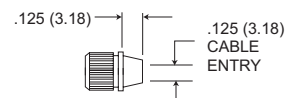

REMOVABLES

Converts R Coaxial Cavity to hold #16, 14 and 8 amps contact.

Contact Ratings 10 15 and 40 amps
Wire Size 16, 14 and 8



Contact Variations

The contact variations shown are modifications of the basic arrangement. For variations not shown please consult factory.

Arr. No.	Basic Arr.	No. of Contacts (Wire Size)					Coax	Spl.	Notes/Modifications
		20	16	14	10	8			
V14	T14						14	Supplied less coaxial contacts (see pg.107 for avail.)	
20	32C2		18				2	#5, 7, 9, 12-17, 29, A1, A2 are open	
B20C2	B20C2		12	6			2	Basic arr. str. coax RG-7/U, P249-0365-000; S249-0366-000	
C20C2	B20C2		12	6			2	A1, A2-str. coax RG-59/U, RG-62/U, P249-0399-000, S249-0398-000	
G20	G20			10	2	8		Basic arr.	
B22C2	32C2		18				2	A1-90° Short coax RG-58/U, P249-0409-000, S249-0410-000; A2-Str. coax RG-58/U, P249-0257-000, S249-0258-000, #11-14, 16, 17, 26-29 open	
23C3	23C3		20				3	Basic arr. str. coax RG-7/U, P249-0365-000, S249-0366-000	
23HV1	23C3		20				2	#21, 23-#8 removable; #22-HV kit 7.5K VAC: #16 wire, 20 amps	
G23C3	23C3		20				3	#21-23-str. coax RG-59/U, RG-62/U, P249-0399-000, S249-0398-000	
B28	B28		28					Basic arr.	
30	32C2		28				2	A1, A2-open	
31	32C2		28				3	A1-open; A2-#8 removable	
B31C1	32C2		28				2	A1-open; A2-90° short coax, RG-58/U P249-0257-000, S249-0258-000	
32	32C2		28				4	A1, A2-#8 removable	
32C1	32C2		28				3	A1-str. coax RG-7/U, P249-0365-000, S249-0366-000 A2-#8 removable	
32C1HV1	32C2		28				2	A1-str. coax RG-7/U, P249-0365-000, S249-0366-000 A2-HV kit, 7.5K VAC, #16 wire, 10 amp	
32C2	32C2		28				2	Basic arr. A1, A2-str. coax RG-7/U, P249-0365-000, S249-0366-000	
A32	32C2		30				2	A1, A2-#16 removable	
E32C2	32C2		28				2	A1, A2-str. coax. RG-58/U, P249-0257-000, S249-0258-000	
T32C2	32C2		28				2	S/A E32C2 except RG-58/U insulated	
U32C2	32C2		28				2	A1, A2-str. coax RG-59/U, RG-62/U, P249-0399-000, S249-0398-000	
40	40		40					Basic arr.	
A44	A44	16	17		6	5		Basic arr.	
45	45		43		2			Basic arr.	
50	50		50					Basic arr.	
F54	F54		48	12				Basic arr.	
76	76	73	3					Basic arr.	
78	78		78					Basic arr.	
C78	78		78					Contacts accommodate 16-20 wire DPDMA only	
90	90		90					Basic arr.	
112	112	112						Basic arr.	
128	128	128						Basic arr.	

Dimensions shown in inch (mm)
Specifications and dimensions subject to change

www.ittcannon.com



Engaging Devices

Female

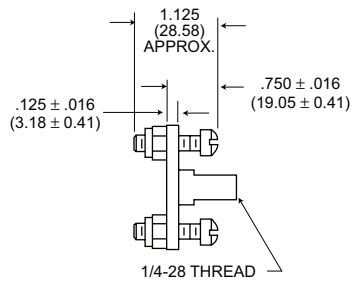

P/N 013837-0010
F
1/4-28 UNF-2B Thread

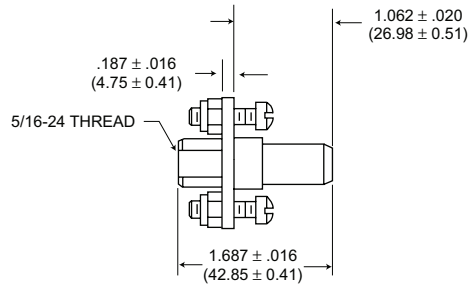

P/N 013837-0003
CF
5/16-24 UNF-2B Thread

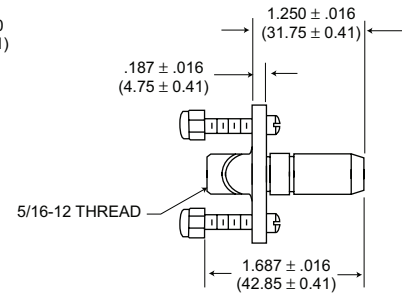

P/N 013837-0013
DF
5/16-12 Quad Lead Thread

Male

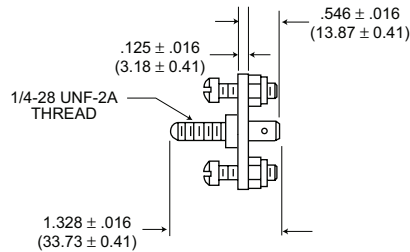

P/N 013837-0008
M
1/4-28 UNF-2A Thread

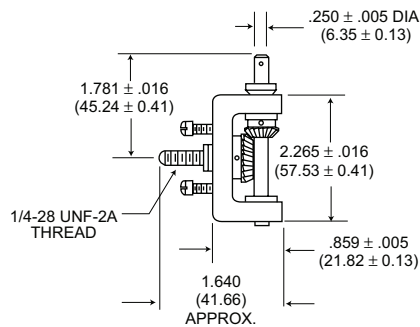

P/N 013837-0001
MA
1/4-28 UNF-2A Thread
NOT FOR USE
WITH POLARIZING POST

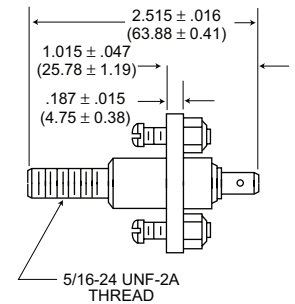

P/N 013837-0005
CM
5/16-24 UNF-2A Thread

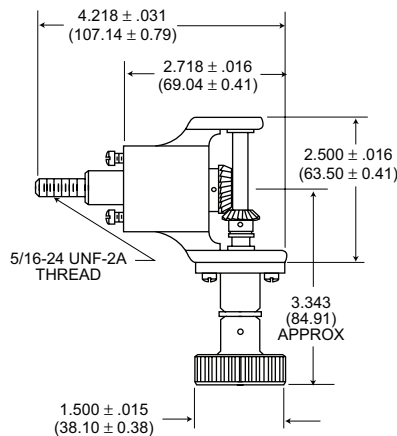

P/N 013837-0042
CMRA
5/16-24 UNF-2A Thread
(Ratchet Lock)

Contact Customer Service for availability.

Dimensions shown in inch (mm)
Specifications and dimensions subject to change

www.ittcannon.com



DPD/DPDMA

Polarization

DPD/DPDMA



DPD 33 with
POLARIZING POSTS

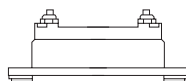

DPD 34 with
POLARIZING KEYWAYS

DPD connectors can be supplied with polarizing posts to provide six or more alternate positions. This feature prevents cross plugging where two identical connectors are mounted close together. Shells with polarizing posts can be ordered by adding the desired position to the part number; for example: DPD-12C4-34P-1A-POS. Y. Polarizing positions are shown below and are face view of the 33 (plug) shell.

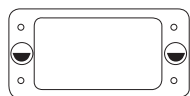

POSITION N

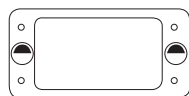

POSITION V

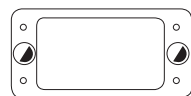

POSITION W

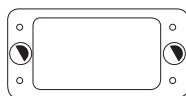

POSITION X

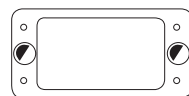

POSITION Y

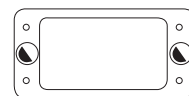

POSITION Z

Shaded area indicates extended portion of polarizing post.

DPD2/DPD2MA

DPD2 series can be supplied with two polarizing posts to provide six or more alternate positions. This feature is designed to assist in preventing cross

plugging. At present shells are modified upon request only, by adding the desired position to the part number; e.g., DPD2-156-34PM-Pos. V. See

drawing below for available positions. Polarizing positions shown are face view of 33 shell.

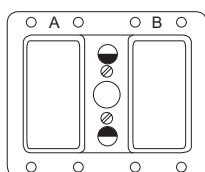

POSITION N

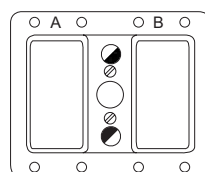

POSITION V

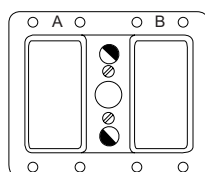

POSITION W

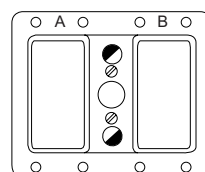

POSITION X

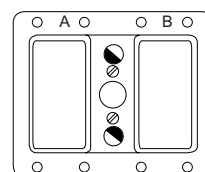

POSITION Y

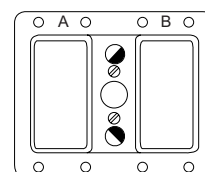

POSITION Z

Shaded area indicates extended portion of polarizing post.

Panel Cutouts

DPD

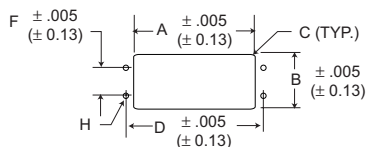

DPD2

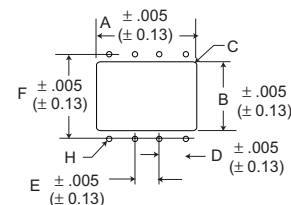

Type	Clearance Hole			Mounting Hole			H Dia.	Gap Between Flanges After Mating
	A Length Front/Rear Mounting	B Width Front/Rear Mounting	C Radius Max.	D	E	F		
DPD-34P	2.562 (65.07)	1.562 (39.67)	.181 (4.60)	2.875 (73.02)	-	1.000 (25.40)	.144 (3.66)	.140 (3.56)
DPD-33S	2.421 (61.49)	1.421 (36.09)	.125 (3.18)	2.875 (73.02)	-	1.000 (25.40)	.144 (3.66)	.140 (3.56)
DPD2-34-P	3.781 (96.04)	2.562 (65.07)	.187 (4.75)	1.000 (25.40)	1.250 (31.75)	2.875 (73.02)	.144 (3.66)	.140 (3.56)
DPD2-33S	3.671 (93.24)	2.421 (61.49)	.125 (3.18)	1.000 (25.40)	1.250 (31.75)	2.875 (73.02)	.144 (3.66)	.140 (3.56)



Dimensions shown in inch (mm)
Specifications and dimensions subject to change

www.ittcannon.com

Accessories-DPD Junction Shell

DPD-33
11612

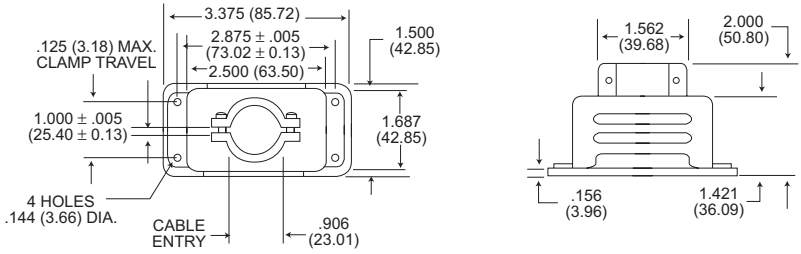

DPD-34
12172

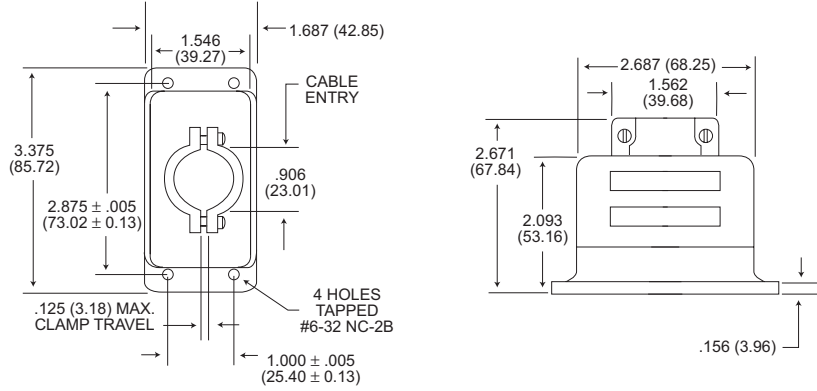

DPD 90°
19929

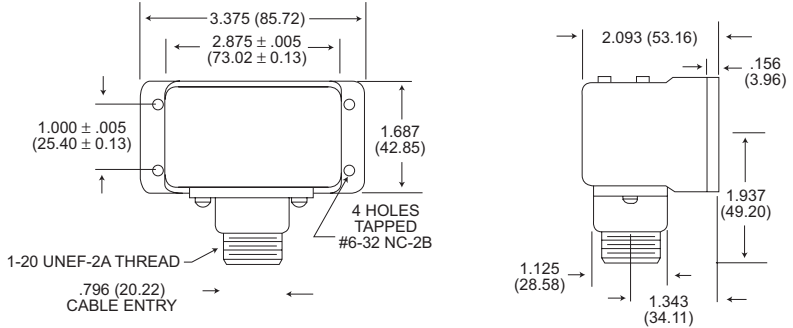

All tolerances ± .015 (0.38) unless otherwise noted.

Accessories-DPD Dust Cap

DPD/DPD2 025-0585-000



Dimensions shown in inch (mm)
Specifications and dimensions subject to change
www.ittcannon.com



DPD/DPDMA

Accessories-DPD2

DPD2
19941-1

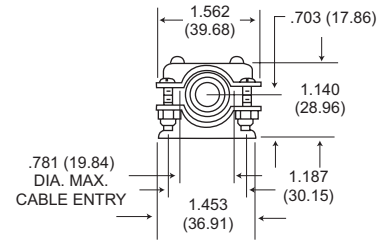
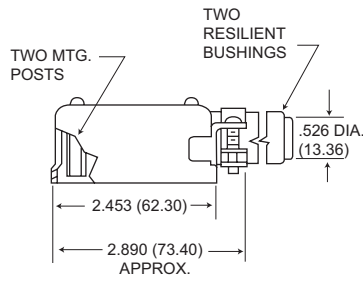

DPD2
19941-2

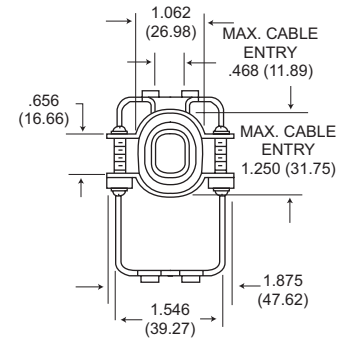
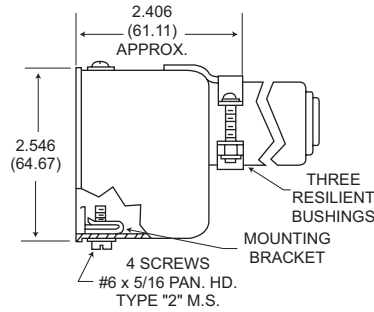

DPD2
19941-3

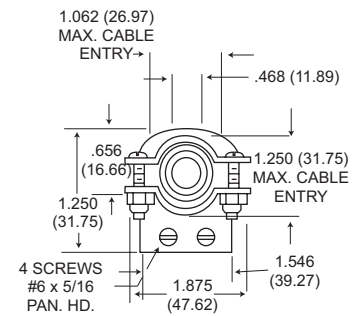
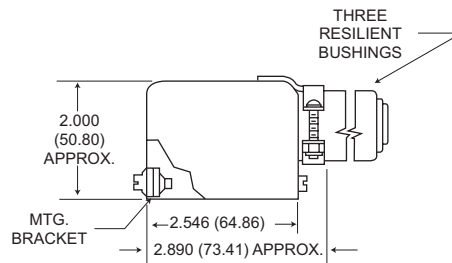

DPD2
19941-7

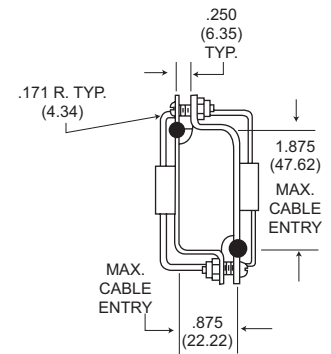
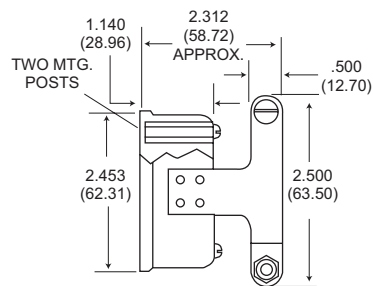

Dimensions shown in inch (mm)
Specifications and dimensions subject to change

www.ittcannon.com



THIS NOTE MUST BE READ IN CONJUNCTION WITH THE PRODUCT DATA SHEET/CATALOG. FAILURE TO OBSERVE THE ADVICE IN THIS INFORMATION SHEET AND THE OPERATING CONDITIONS SPECIFIED IN THE PRODUCT DATA SHEET/ CATALOG COULD RESULT IN HAZARDOUS SITUATIONS.

1. MATERIAL CONTENT AND PHYSICAL FORM

Electrical connectors do not usually contain hazardous materials. They contain conducting and non-conducting materials and can be divided into two groups.

- a) Printed circuit types and low cost audio types which employ all plastic insulators and casings.
- b) Rugged, Fire Barrier and High Reliability types with metal casings and either natural rubber, synthetic rubber, plastic or glass insulating materials. Contact materials vary with type of connector and also application and are usually manufactured from either: Copper, copper alloys, nickel, alumel, chromel or steel. In special applications, other alloys may be specified.

2. FIRE CHARACTERISTICS AND ELECTRIC SHOCK HAZARD

There is no fire hazard when the connector is correctly wired and used within the specified parameters. Incorrect wiring or assembly of the connector or careless use of metal tools or conductive fluids, or transit damage to any of the component parts may cause electric shock or burns. Live circuits must not be broken by separating mated connectors as this may cause arcing, ionization and burning. Heat dissipation is greater at maximum resistance in a circuit. Hot spots may occur when resistance is raised locally by damage, e.g. cracked or deformed contacts, broken strands of wire. Local overheating may also result from the use of the incorrect application tools or from poor quality soldering or slack screw terminals. Overheating may occur if the ratings in the product Data Sheet/Catalog are exceeded and can cause breakdown of insulation and hence electric shock. If heating is allowed to continue it intensifies by further increasing the local resistance through loss of temper of spring contacts, formation of oxide film on contacts and wires and leakage currents through carbonization of insulation and tracking paths. Fire can then result in the presence of combustible materials and this may release noxious fumes. Overheating may not be visually apparent. Burns may result from touching overheated components.

3. HANDLING

Care must be taken to avoid damage to any component parts of electrical connectors during installation and use. Although there are normally no sharp edges, care must be taken when handling certain components to avoid injury to fingers. Electrical connectors may be damaged in transit to the customers, and damage may result in creation of hazards. Products should therefore be examined prior to installation/use and rejected if found to be damaged.

4. DISPOSAL

Incineration of certain materials may release noxious or even toxic fumes.

5. APPLICATION

Connectors with exposed contacts should not be selected for use on the current supply side of an electrical circuit, because an electric shock could result from touching exposed contacts on an unmated connector. Voltages in excess of 30 V ac or 42.5 V dc are potentially hazardous and care should be taken to ensure that such voltages cannot be transmitted in any way to exposed metal parts of the connector body. The connector and wiring should be checked, before making live, to have no damage to metal parts or insulators, no solder blobs, loose strands, conducting lubricants, swarf, or any other undesired conducting particles. Circuit resistance and continuity check should be made to make certain that there are no high resistance joints or spurious conducting paths. Always use the correct application tools as specified in the Data Sheet/Catalog. Do not permit untrained personnel to wire, assemble or tamper with connectors. For operation voltage please see appropriate national regulations.

IMPORTANT GENERAL INFORMATION

(i) Air and creepage paths/Operating voltage. The admissible operating voltages depend on the individual applications and the valid national and other applicable safety regulations.

For this reason the air and creepage path data are only reference values. Observe reduction of air and creepage paths due to PC board and/or harnessing.

(ii) Temperature

All information given are temperature limits. The operation temperature depends on the individual application.

(iii) Other important information

Cannon continuously endeavors to improve their products. Therefore, Cannon products may deviate from the description, technical data and shape as shown in this catalog and data sheets.

“Engineered for life” is a registered trademark of ITT Corporation ©2007. All other trademarks or registered trademarks are property of their respective owners. All data subject to change without notice.

Product Warranty

ITT Electronic Components, a Division of ITT Corporation manufactures the highest quality products available in the marketplace; however these products are intended to be used in accordance with the specifications in this publication. Any use or application that deviates from the stated operating specifications is not recommended and may be unsafe. No information and data contained in this publication shall be construed to create any liability on the part of Cannon. Any new issue of this publication shall automatically invalidate and supersede any and all previous issues. A limited warranty applies to Cannon products. Except for obligations assumed by Cannon under this warranty, Cannon shall not be liable for any loss, damage, cost of repairs, incidental or consequential damages of any kind, whether or not based on express or implied warranty, contract, negligence or strict liability arising in connection with the design, manufacture, sale, use or repair of the products. Product availability, prices and delivery dates are exclusively subject to our respective order confirmation form; the same applies to orders based on development samples delivered. This publication is not to be construed as an offer. It is intended merely as an invitation to make an offer. By this publication, Cannon does not assume responsibility or any liability for any patent infringements or other rights of third parties which may result from its use. Reprinting this publication is generally permitted, indicating the source. However, Cannon's prior consent must be obtained in all cases.



Rack & Panel Connectors

ITT is the world leader in rack and panel connectors, offering unmatched variety of shell configurations and insert arrangements, materials, plating and contact options. Many of our standard and custom designs meet the stringent requirements of ARINC 600, ARINC 404 (MIL-C-81659), and MIL-DTL-83733 standards.



www.ittcannon.com/rackandpanel

Circular/Filter/Hermetic Connectors

As a world leader in circular, filter and hermetic connectors, ITT can leverage its design and manufacturing expertise to fit virtually any application. Our expertise includes fast positive mating for a wide range of military applications, as well as numerous sizes and contact configuration for various harsh environments. ITT can also meet numerous specs, including NATO and MIL standards.



www.ittcannon.com/circulars • www.ittcannon.com/filter • www.ittcannon.com/hermetics

D-Subminiature Connectors

Cannon invented D-sub connectors in 1952. Our family of D-Subs now includes combinations of signal, power and RF, as well as severe service sealed connectors. Cannon D-Subs are available with an extensive line of backshells and accessories and are one of the most economical shielded connector solutions available. Qualified to the MIL-DTL-24308 specification.



www.ittcannon.com/dsubs

Fiber Optic Connectors and Cable Assemblies

Cannon fiber optic solutions provide an excellent performance/cost value. Performance can be tailored to the end system, and our use of superior materials and bonding agents provides highly effective solutions. Our wide variety of products includes fiber optic hybrid contacts, multi-channel, rack and panel, and hi-rel assemblies, including MIL and ARINC standard solutions.



www.ittcannon.com/fiberoptics

Microminiature Connectors

Cannon microminiature connectors offer high performance and reliability with exceptional versatility. Available in rectangular, circular and strip configurations for countless applications, many of our connectors meet or exceed applicable requirements of the MIL-DTL-83513 specification.



www.ittcannon.com/micro

ITT's Electronic Components business (www.ittcannon.com) is an international supplier of connectors, interconnects, cable assemblies, I/O card kits and smart card systems. As a worldwide leader in connector technology for nearly a century, ITT offers one of the industry's broadest product offerings, manufacturing capability worldwide, fast time to market, high volume/high yield capacity, robust design and Value-Based Product Development and an extensive sales and customer support network.





ITT

Cannon Rack & Panel Connectors Customer Support Locations

ASIA

Tuopandun Industrial Area, Jinda Cheng,
Xiner Village, Shajing Town,
Baoan District, Shenzhen City,
Guangdong, China 518125
Phone: 86.755.2726.7238
Fax: 86.755.2726.7515

GERMANY

Cannonstrasse 1
Weinstadt, 71384
phone: 49.7151.699.0
fax: 49.7151.699.217

ITALY

Corso Europa 41/43
Lainate (MI),
Italy 20020
phone: 39.02938721
fax: 39.0293872300

UK

Jays Close, Viabes Estate
Basingstoke, RG22 4BA
phone: 44.1256.311200
fax: 44.1256.323356

USA

666 East Dyer Road
Santa Ana, CA 92705
toll free: 1.800.854.3028
phone: 1.714.557.4700
fax: 1.714.628.2142