

PROPER USE GUIDELINES

Cumulative Trauma Disorders can result from the prolonged use of manually powered hand tools. Hand tools are intended for occasional use and low volume applications. A wide selection of powered application equipment for extended-use, production operations is available.

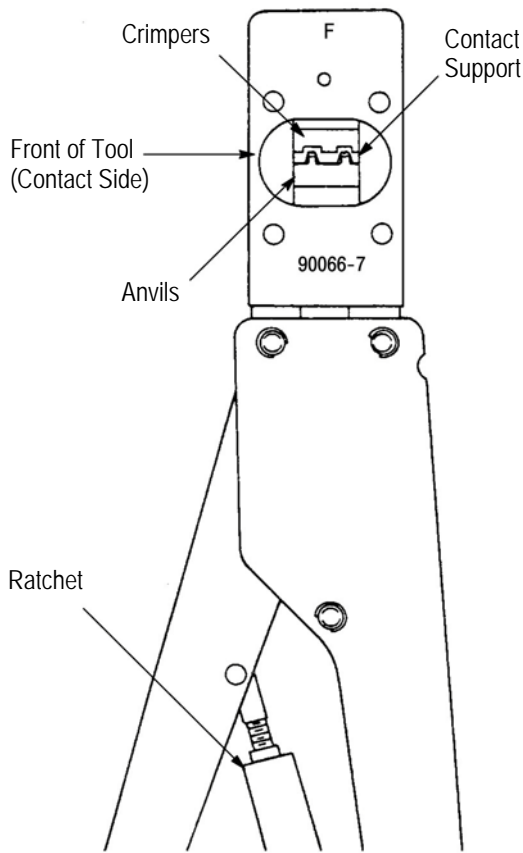

Figure 1

1. INTRODUCTION

Hand Crimping Tool 90066-7 and Head Assembly 90066-9 (shown in Figure 1) are designed to crimp Type III+ and Type VI, and commercial MATE-N-LOK* contacts listed in Figure 2. Read these instructions thoroughly before crimping any contacts.

NOTE *All dimensions on this document are in metric units [with U.S. customary units in brackets]. Figures and illustrations are for reference only and are not drawn to scale.*

Reasons for reissue of this instruction sheet are provided in Section 6, REVISION SUMMARY.

2. DESCRIPTION (Figures 1 and 2)

The front of the tool (contact side), into which the contact is inserted, has the tool number marked on it.

The back of the tool (wire side), into which the wire is inserted, has the wire size and color-code dots marked above each crimping chamber.

The tool features two fixed dies (crimpers), two movable dies (anvils), two crimping chambers, a contact support, a locator/insulation stop, an ejector, and ratchet.

The ratchet ensures full crimping of the contact. Once engaged, the ratchet will not release until the handles have been FULLY closed.

CAUTION *The dies bottom before the ratchet releases. This is feature ensures maximum electrical and tensile performance of the crimp. DO NOT re-adjust the ratchet.*

The locator/insulation stop has two functions. First, it positions the contact between the crimping dies, and second, it aids in locating the wire in the contact. In use, it rests in the locator slot. See Figures 2 and 3.

The contact support prevents the contact from bending during crimping. The ejector pulls the locator down and ejects the crimped contact when the tool handles are FULLY opened.

NOTE *Type III+ contacts have a color dot located on the contact spring. Type VI contacts have the applicable wire size stamped on the underside of the insulation barrel.*

3. CRIMPING PROCEDURE

Refer to Figure 2, and select wire of the specified size and insulation diameter for the type and part number of loose piece contact. Strip the wire to the length indicated. DO NOT cut or nick the wire strands.

On the BACK of the tool, identify the appropriate crimping chamber (according to the color dot and/or wire size markings). The markings on the contact must match the markings on the appropriate crimping chamber of the tool.

Refer to Figure 3, and proceed as follows:

1. Hold the tool so the BACK (wire side) is facing you.
2. Make sure the ratchet is released by squeezing the handles and allowing them to open FULLY.
3. Insert the contact (insulation barrel first) into the FRONT of appropriate crimping chamber. Position the contact in the crimpers so that the locator enters the locator slot of the contact.

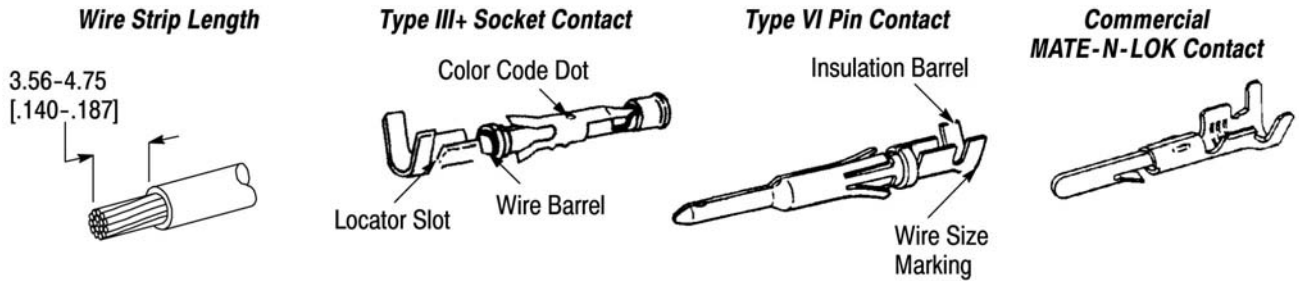

WIRE		CONTACT					CRIMPING CHAMBER (Wire Size Marking)	CRIMP DOT CODE
SIZE (AWG)	INSULATION DIAMETER	TYPE	LOOSE PIECE		STRIP			
			PIN	SOCKET	PIN	SOCKET		
30-26	1.02-1.52 [.040-.060]	III+	66429	66428	66425	66424	24-20 30-26	2 Dots
28-24	0.89-1.40 [.035-.055]	VI	66595	66596	66585	66586	28-24 30-22	1 Dot
26-24		III+	66107	66109	66106	66108		
24-20	1.02-2.03 [.040-.080]	III+	66103	66105	66102	66104	24-20 30-26	2 Dots
		VI	66593	66594	66583	66584		
30-22	1.02-1.91 [.040-.075]	Commercial MATE-N-LOK	61174	61173	350079	350078	28-24 30-22	1 Dot

Figure 2

4. Hold the contact in this position and squeeze the tool handles together until the insulation anvil starts entry into the insulation crimper. DO NOT deform the insulation barrel or wire barrel.

5. Insert a properly stripped wire through the wire slot in the locator and into wire barrel of the contact until the insulation butts against the locator/insulation stop.

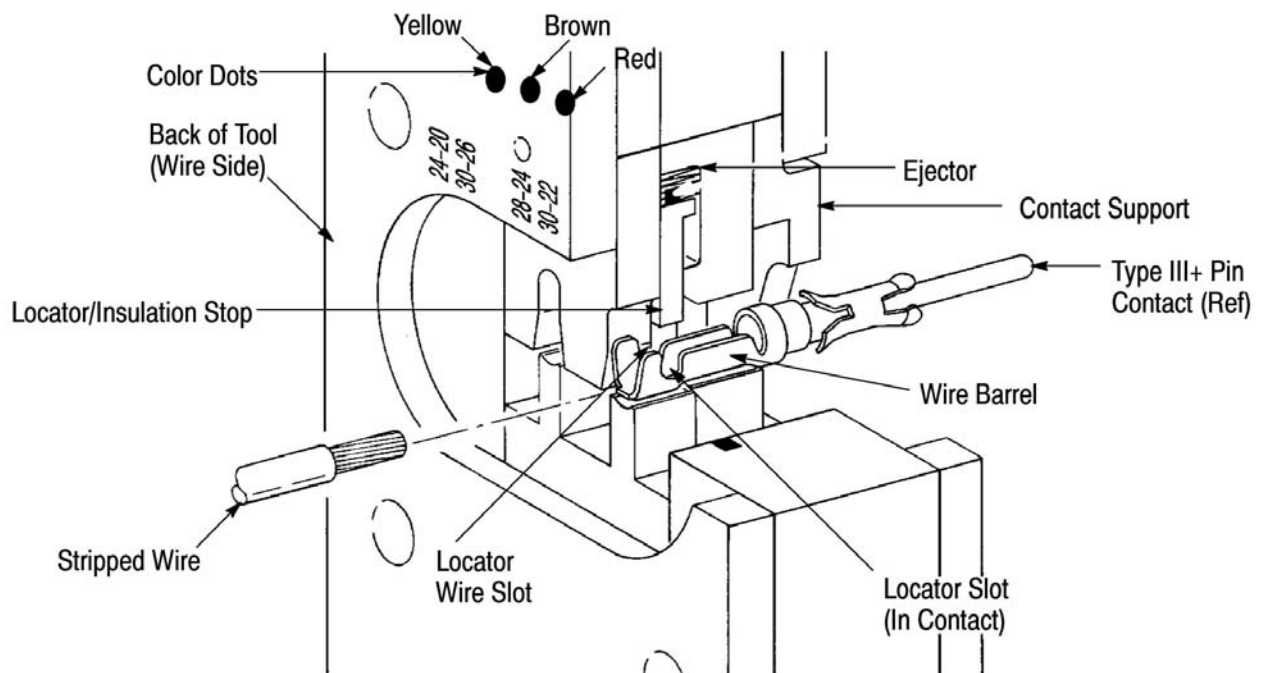

Figure 3



Special precautions must be taken when inserting a wire into a contact crimped in the crimping chamber marked "24-20/30-26". The full length of the stripped wire must rest on the bottom of the wire barrel. For information concerning this "crush crimp" technique, refer to Instruction Sheet 408-7497.

6. Holding the wire in place, squeeze the tool handles until ratchet releases, then remove the crimped contact.



Damaged contacts must not be used. If a damaged product is evident, it should be cut from the wire and replaced with a new one. DO NOT re-terminate contacts.

4. MAINTENANCE AND INSPECTION

It is recommended that a maintenance and inspection program be performed periodically to ensure dependable and uniform terminations. Though recommendations call for at least one inspection a month, frequency of inspection depends on:

- care, amount of use, and handling of the hand tool
- presence of abnormal amounts of dust and dirt
- degree of operator skill
- your own established standards

The tool is inspected before being shipped; however, it is recommended that the tool be inspected immediately upon arrival at your facility to ensure that the tool has not been damaged during shipment.

4.1. Daily Maintenance

1. The hand tool should be immersed (handles partially closed) in a reliable commercial degreasing compound to remove accumulated dirt, grease, and foreign matter. When degreasing compound is not available, the tool may be wiped clean with a soft, lint-free cloth. DO NOT use hard or abrasive objects that could damage the tool.

2. Make certain that the retaining pins are in place and that they are secured with retaining rings.



DO NOT remove the retaining pins as permanent damage to the tool could result.

3. All pins, pivot points, and bearing surfaces should be protected with a THIN coat of any good SAE 20 motor oil. DO NOT oil excessively.

When the tool is not in use, keep handles closed to prevent objects from becoming lodged in the dies. Store the tool in a clean, dry area.

SAE is a trademark.

4.2. Periodic Inspection

At least one inspection a month is recommended and the inspection frequency should be based on the amount of use, ambient working conditions, operator training and skill, and company established standards.

A. Lubrication

Keep all pins, pivot points, and bearing surfaces lubricated with SAE 20 motor oil as follows:

- Tool used in daily production-lubricate daily
- Tool used daily (occasionally)-lubricate weekly
- Tool used weekly-lubricate monthly

Wipe excess oil from the tool, particularly from the crimping area. Oil transferred from the crimping area onto certain terminations may affect the electrical characteristics of an application.

B. Visual Inspection

1. Close the tool handles until the ratchet releases and then allow them to open freely. If they do not open quickly and fully, return the tool for evaluation and repair. See Section 5, REPLACEMENT AND REPAIR.

2. Inspect the head assembly for worn, cracked, or broken areas. If damage is evident, return the tool for evaluation and repair. See Section 5, REPLACEMENT AND REPAIR.

C. Crimp Height Inspection

This inspection incorporates the use of a crimp height comparator (micrometer with a modified anvil) as shown in Figure 4. Detailed information on obtaining and using a crimp height comparator can be found in Instruction Sheet 408-7424.

Proceed as follows:

1. Determine the maximum wire size, and select the applicable contact for the tool (see Figure 1).
2. Refer to Section 3, CRIMPING PROCEDURE, and crimp the contact accordingly.
3. Using the crimp height comparator, measure the wire barrel crimp height as shown in Figure 4.

If the crimp height conforms to the dimensions shown in Figure 4, the tool is considered dimensionally correct. If not, return the tool for evaluation and repair (see Section 5, REPLACEMENT AND REPAIR).

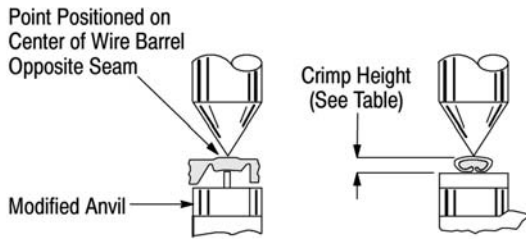

CONTACT NO. (Loose Piece)		MAXIMUM WIRE SIZE (AWG)	CRIMPING CHAMBER (Wire Size Marking)	CRIMP HEIGHT
66429	66428	26	24-20 30-26	1.003 ±0.051 [.0395 ±.0020]
66107	66109	24	28-24 30-22	0.787 ±0.038 [.0310 ±.0015]
66595	66596			
66593	66594	20	24-20 30-26	1.003 ±0.051 [.0395 ±.0020]
66103	66105			
61173	61174	22	28-24 30-22	0.851 ±0.051 [.0335 ±.0020]

Figure 4

D. Ratchet Inspection

The ratchet should be checked to ensure that it does not release prematurely, allowing the dies to open before they have fully bottomed. Obtain a 0.025 mm [.001 in.] shim that is suitable for checking the clearance between the bottoming surfaces of the dies, then proceed as follows:

1. Select a contact and maximum size wire for the tool.

2. Position the contact and wire in the dies, as described in Section 3, CRIMPING PROCEDURE.

3. Holding the wire in place, squeeze the handles until the ratchet releases. Hold the handles in this position, maintaining just enough tension to keep the dies closed.

4. Check the clearance between the bottoming surfaces of the dies. If the clearance is 0.025 mm [.001 in.] or less, the ratchet is satisfactory. If clearance exceeds 0.025 mm [.001 in.], the ratchet is out of adjustment and must be repaired. See Section 5, REPLACEMENT AND REPAIR.

5. REPLACEMENT AND REPAIR

The part shown in Figure 5 is customer-replaceable. A complete inventory can be stocked and controlled to prevent lost time when replacement of the part is necessary. Order replacement parts through your TE Representative, or call 1-800-526-5142, or send a facsimile of your purchase order to 1-717-986-7605, or write to:

CUSTOMER SERVICE (038-035)
 TYCO ELECTRONICS CORPORATION
 PO BOX 3608
 HARRISBURG PA 17105-3608

For customer repair service, call 1-800-526-5136.

6. REVISION SUMMARY

Revisions to this instruction sheet include:

- Updated document to corporate requirements
- Added product part numbers to table in Figure 4

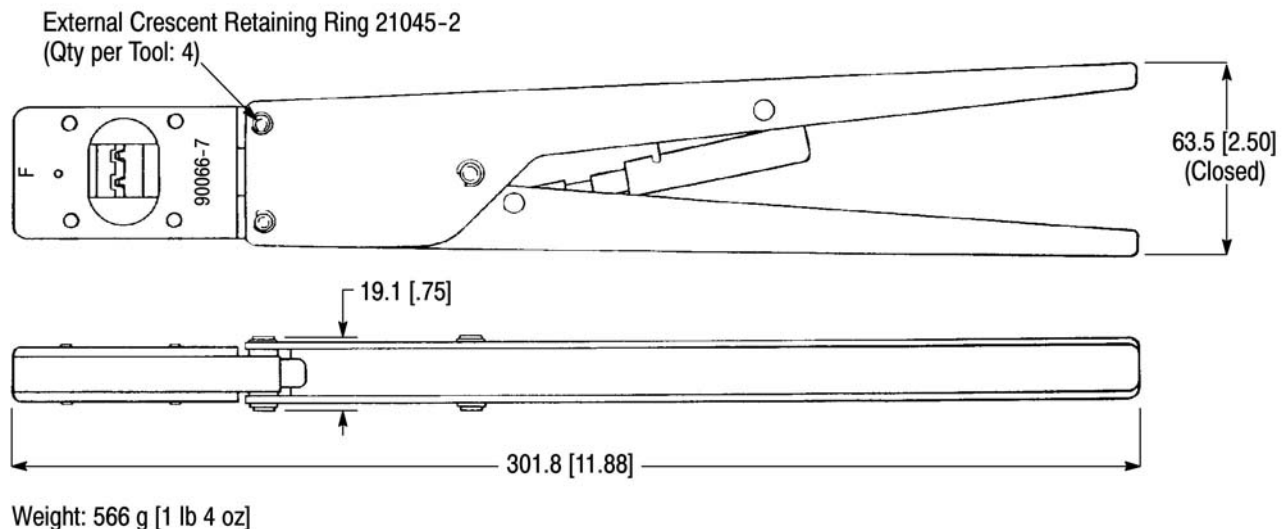

Figure 5