

CASA Part Number for BLANK = "RP-3U-AL3N(BLANK)"

Standard Finishes Available include:

AN = Anodizing Natural

- 1) Degrease
- 2) Etch 5~10 minutes maximum
- 3) De-smut
- 4) Anodize 10~15 microns to Mat/Satin finish
- 5) Boiling Water Seal

CAC 1

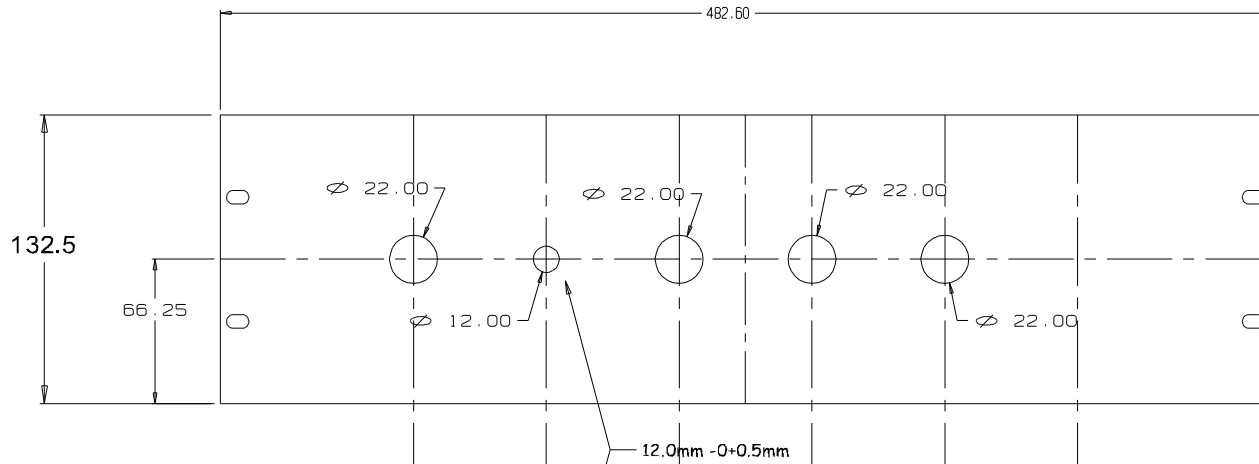

CAC 2

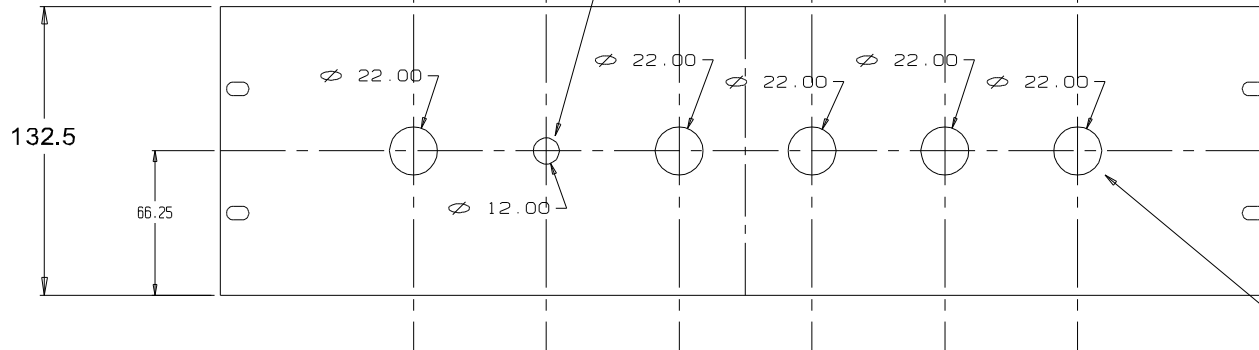

MSG

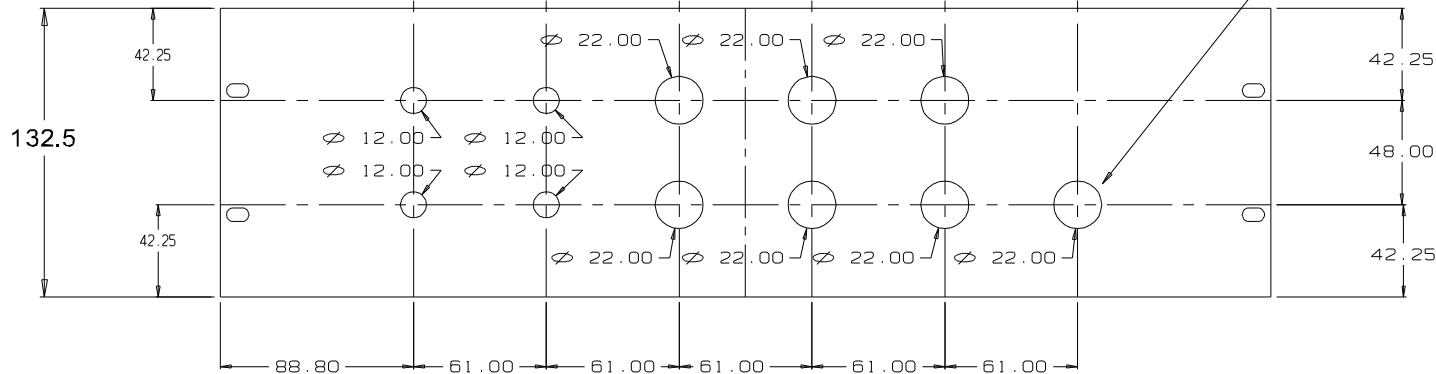

MATERIAL	Alloy Sht 3.0mm
ALLOY	5005
EST. AREA	20726mm ² /U
EST. WEIGHT	0.33Kg/U
EST. PERIPHERY	EXT: XXX mm TDT: XXX mm
TOLERANCE	0.00mm ±0.1mm 00.0mm ±0.25mm 0000mm ±0.5mm 0-500mm ±0.1mm > 500mm ±0.5mm
BS1474:1987	APPLIES UNLESS OTHERWISE SPECIFIED
SURFACE FINISH	Visible surfaces denoted - - -
NATURAL	<input type="checkbox"/>
LYNISH	<input type="checkbox"/>
DE-BURR	<input type="checkbox"/>
ANODISE	<input type="checkbox"/>
PAINT	<input type="checkbox"/>
PLATE	<input type="checkbox"/>
ALLODIZE	<input type="checkbox"/>
SHOTBLAST	<input type="checkbox"/>
OTHER DETAIL	<input type="checkbox"/>
See Notes	<input type="checkbox"/>
JOB No.	

CASA Modular Systems P.O. BOX 38-828, WELLINGTON, NEW ZEALAND TELEPHONE : (64-4) 9393 777 FACSIMILE : (64-4) 9393 778 E-MAIL : sales@casa.co.nz	CUSTOMER :	Heiner Wiegand			SIZE	DRAWING Reference No.		ISSUE
	DESCRIPTION :	RACK PANELS 3U (US Embassy)			A4	RP-3U-USE		A
DRAWN :	DATE :	APPROVED :	DWG. SCALE :	© COPYRIGHT : CASA Modular Systems ALL RIGHTS RESERVED				
AWD	01/9/04	?	1:1					