

Wirewound Resistors, Industrial Power, Vitreous Coated, Adjustable Tubular

FEATURES

- High temperature vitreous coating
- Complete welded construction
- Tight tolerance of 5 % for values above 1 Ω
- Excellent stability in operation (< 3 % change in resistance)
- Material categorization:
For definitions of compliance please see www.vishay.com/doc?99912



RoHS
COMPLIANT
HALOGEN
FREE
GREEN
(5-2008)

STANDARD ELECTRICAL SPECIFICATIONS

GLOBAL MODEL	HISTORICAL MODEL	POWER RATING $P_{25\text{ }^\circ\text{C}}$ W	TOLERANCE \pm %	RESISTANCE VALUE Ω	WEIGHT (typical) g
AVT010	AVT-10	12	5, 10	0.1 to 10.2K	6.69
AVT025	AVT-25	25	5, 10	0.1 to 23K	20.72
AVT25A	AVT-25A	30	5, 10	0.1 to 30K	20.72
AVT25B	AVT-25B	30	5, 10	0.1 to 24K	14.25
AVT050	AVT-50	50	5, 10	0.1 to 57K	42.08
AVT50A	AVT-50A	60	5, 10	0.1 to 75K	65.64
AVT50B	AVT-50B	70	5, 10	0.1 to 84.3K	64.82
AVT075	AVT-75	75	5, 10	0.1 to 85.5K	106.37
AVT75A	AVT-75A	90	5, 10	0.1 to 114K	183.82
AVT100	AVT-100	100	5, 10	0.1 to 132K	91.37
AVT130	AVT-130	130	5, 10	0.1 to 192K	192.36
AVT160	AVT-160	175	5, 10	0.1 to 398K	250.8
AVT200	AVT-200	225	5, 10	0.1 to 337K	309.97

GLOBAL PART NUMBER INFORMATION

Global Part Numbering example: **AVT02506E25R00JE** (visit www.vishay.net SAP parts manual for all options)

A
V
T
0
2
5
0
6
E
2
5
R
0
0
J
E

GLOBAL MODEL (6 digits)	TERMINAL DESIGNATION (2 digits)	TERMINAL FINISH (1 digit)	VALUE (5 digits)	TOLERANCE (1 digit)	PACKAGING CODE (1 digit)	SPECIAL (up to 2 digits)
(See Standard Electrical Specifications Global Model column for options)	05 06 14 15 20 FC = Ferrule cap	E = Lead (Pb)-free	R = Decimal K = Thousand 1R500 = 1.5 Ω 1K500 = 1.5 k Ω	J = \pm 5 % K = \pm 10 %	E = E01 = Lead (Pb)-free skin pack	(Dash number) From 1 to 99 as applicable 91 = 100 style BKT 92 = 200 style BKT 93 = 300 style BKT

Historical Part Number example: **AVT-25-25-5 %**

AVT-25	25 Ω	5 %	
HISTORICAL MODEL	RESISTANCE VALUE	TOLERANCE	SPECIAL

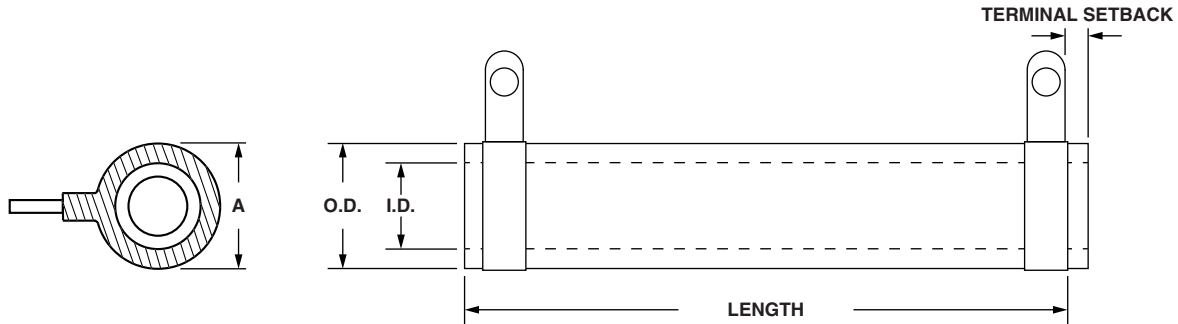
DIMENSIONS in inches [millimeters]

MODEL	DIMENSIONS in inches [millimeters]									
	A (MAX.)	CORE DIMENSIONS			TERMINAL SETBACK ± 0.031 (0.79)	DISTANCE BETWEEN TERMINALS (REF.)	TERMINAL DESIGNATION		SLIDER MODEL NUMBER	BRACKET TYPES
		LENGTH ± 0.062 (1.59)	O.D.	I.D. ± 0.031 (0.79)			STANDARD	OPTIONAL (QUICK CONNECT)		
AVT010	0.406 [10.31]	1.750 [44.45]	0.313 [7.95]	0.188 [4.78]	0.094 [2.39]	1.187 [30.15]	05	14	70	101, 204, 301
AVT025	0.668 [17.48]	2.000 [50.8]	0.563 [14.30]	0.313 [7.95]	0.094 [2.39]	1.312 [33.32]	06	15	71	101, 203, 301
AVT25A	0.906 [23.01]	2.000 [50.8]	0.750 [19.05]	0.500 [12.7]	0.094 [2.39]	1.312 [33.32]	06	15	72	101, 203, 301
AVT25B	0.770 [19.56]	2.000 [50.8]	0.625 [15.88]	0.453 [11.51]	0.094 [2.39]	1.312 [33.32]	06	15	72	102, 206, 303
AVT050	0.688 [17.48]	4.000 [101.6]	0.563 [14.30]	0.313 [7.95]	0.094 [2.39]	1.312 [33.32]	06	15	72	102, 206, 303
AVT50A	0.906 [23.01]	4.000 [101.6]	0.750 [19.05]	0.500 [12.70]	0.062 [1.57]	3.376 [85.75]	06	15	73	102, 203, 303
AVT50B	0.906 [23.01]	4.500 [114.3]	0.750 [19.05]	0.547 [13.89]	0.125 [3.18]	3.75 [95.25]	06	15	73	102, 206, 303
AVT075	0.668 [17.46]	6.000 [152.4]	0.563 [14.30]	0.313 [7.95]	0.094 [2.39]	5.312 [134.9]	06	15	72	101, 203, 301
AVT75A	0.906 [23.01]	6.000 [152.4]	0.750 [19.05]	0.500 [12.70]	0.094 [2.39]	5.312 [134.9]	06	15	74	102, 206, 303
AVT100	0.906 [23.01]	6.500 [165.1]	0.750 [19.05]	0.500 [12.70]	0.125 [3.18]	5.750 [146.1]	06	15	73	103, 205, 303
AVT130	1.313[33 .35]	6.500 [165.1]	1.125 [28.58]	0.750 [19.05]	0.282 [7.16]	5.312 [134.9]	20	15	74	103, 205, 303
AVT160	1.313 [33.35]	8.500 [215.9]	1.125 [28.58]	0.750 [19.05]	0.267 [6.78]	7.341 [186.5]	20	15	74	103, 205, 303
AVT200	1.313 [33.35]	10.500 [266.7]	1.125 [28.58]	0.750 [19.05]	0.266 [6.76]	9.343 [237.3]	20	15	74	103, 205, 303

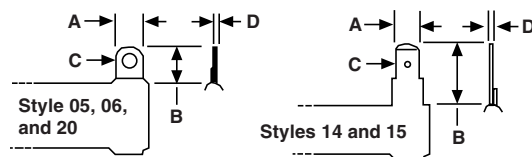
TERMINAL DIMENSIONS

DIMENSIONS	TERMINAL STYLE				
	20	05	06	14	15
A	0.375 [9.53]	0.188 [4.76]	0.250 [6.35]	0.188 [4.76]	0.250 [6.35]
B	0.625 [15.88]	0.438 [11.11]	0.563 [14.29]	0.563 [14.29]	0.594 [15.08]
C (HOLE DIAMETER)	0.196 [4.98]	0.104 [2.64]	0.166 [4.22]	0.050 [1.27]	0.065 [1.65]
D	0.020 [0.51]	0.020 [0.51]	0.020 [0.51]	0.020 [0.51]	0.031 [0.79]



TECHNICAL SPECIFICATIONS		
PARAMETER	UNIT	AVT RESISTOR CHARACTERISTICS
Temperature Coefficient	ppm/°C	± 260 for 20 Ω and above, ± 400 for 1 Ω to 19.99 Ω, special TC's available please contact factory
Short Time Overload	-	10 x rated power for 5 s
Dielectric Withstanding Voltage	V _{AC}	1000, from terminal to mounting hardware
Maximum Working Voltage	V	$(P \times R)^{1/2}$
Operating Temperature Range	°C	- 55 to + 350

MATERIAL SPECIFICATIONS

Element: Copper-nickel alloy or nickel-chrome alloy, depending on resistance value

Core: Ceramic, steatite or cordierite

Coating: Special high temperature vitreous

Standard Terminals: Tinned alloy 42

Optional Terminal (Quick Connect): Alloy 42

Terminal Bands: Alloy 42

Part Marking: HEI, model, wattage, value, tolerance, date code

DERATING

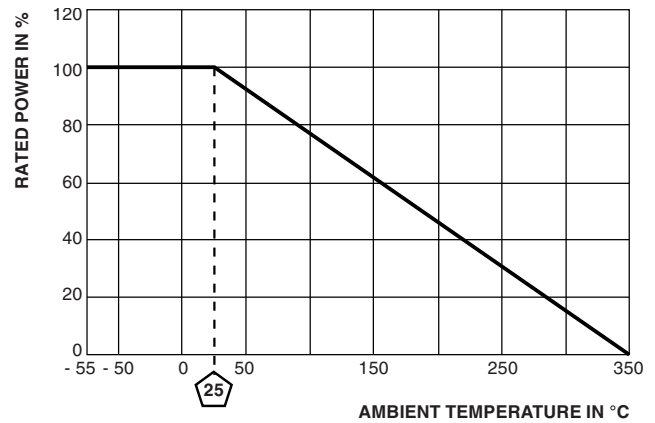



Disclaimer

ALL PRODUCT, PRODUCT SPECIFICATIONS AND DATA ARE SUBJECT TO CHANGE WITHOUT NOTICE TO IMPROVE RELIABILITY, FUNCTION OR DESIGN OR OTHERWISE.

Vishay Intertechnology, Inc., its affiliates, agents, and employees, and all persons acting on its or their behalf (collectively, "Vishay"), disclaim any and all liability for any errors, inaccuracies or incompleteness contained in any datasheet or in any other disclosure relating to any product.

Vishay makes no warranty, representation or guarantee regarding the suitability of the products for any particular purpose or the continuing production of any product. To the maximum extent permitted by applicable law, Vishay disclaims (i) any and all liability arising out of the application or use of any product, (ii) any and all liability, including without limitation special, consequential or incidental damages, and (iii) any and all implied warranties, including warranties of fitness for particular purpose, non-infringement and merchantability.

Statements regarding the suitability of products for certain types of applications are based on Vishay's knowledge of typical requirements that are often placed on Vishay products in generic applications. Such statements are not binding statements about the suitability of products for a particular application. It is the customer's responsibility to validate that a particular product with the properties described in the product specification is suitable for use in a particular application. Parameters provided in datasheets and/or specifications may vary in different applications and performance may vary over time. All operating parameters, including typical parameters, must be validated for each customer application by the customer's technical experts. Product specifications do not expand or otherwise modify Vishay's terms and conditions of purchase, including but not limited to the warranty expressed therein.

Except as expressly indicated in writing, Vishay products are not designed for use in medical, life-saving, or life-sustaining applications or for any other application in which the failure of the Vishay product could result in personal injury or death. Customers using or selling Vishay products not expressly indicated for use in such applications do so at their own risk. Please contact authorized Vishay personnel to obtain written terms and conditions regarding products designed for such applications.

No license, express or implied, by estoppel or otherwise, to any intellectual property rights is granted by this document or by any conduct of Vishay. Product names and markings noted herein may be trademarks of their respective owners.

Material Category Policy

Vishay Intertechnology, Inc. hereby certifies that all its products that are identified as RoHS-Compliant fulfill the definitions and restrictions defined under Directive 2011/65/EU of The European Parliament and of the Council of June 8, 2011 on the restriction of the use of certain hazardous substances in electrical and electronic equipment (EEE) - recast, unless otherwise specified as non-compliant.

Please note that some Vishay documentation may still make reference to RoHS Directive 2002/95/EC. We confirm that all the products identified as being compliant to Directive 2002/95/EC conform to Directive 2011/65/EU.

Vishay Intertechnology, Inc. hereby certifies that all its products that are identified as Halogen-Free follow Halogen-Free requirements as per JEDEC JS709A standards. Please note that some Vishay documentation may still make reference to the IEC 61249-2-21 definition. We confirm that all the products identified as being compliant to IEC 61249-2-21 conform to JEDEC JS709A standards.