

Silicon NPN Power Transistors

BUW11 BUW11A

DESCRIPTION

- With TO-3PN package
- High voltage ;high speed

APPLICATIONS

- Converters
- Inverters
- Switching regulators
- Motor control systems

PINNING (See Fig.2)

PIN	DESCRIPTION
1	Base
2	Collector
3	Emitter

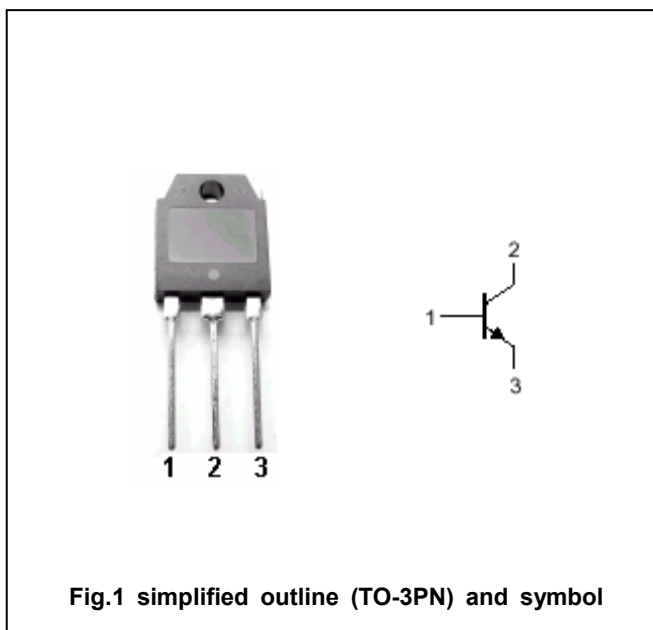

Fig.1 simplified outline (TO-3PN) and symbol

Absolute maximum ratings(Ta=25□)

SYMBOL	PARAMETER	CONDITIONS	VALUE	UNIT
V _{CBO}	Collector-base voltage	BUW11	850	V
		BUW11A	1000	
V _{CEO}	Collector-emitter voltage	BUW11	400	V
		BUW11A	450	
V _{EBO}	Emitter-base voltage	Open collector	9	V
I _C	Collector current		5	A
I _{CM}	Collector current-peak		10	A
I _B	Base current		2	A
I _{BM}	Base current-peak		4	A
P _T	Total power dissipation	T _C =25□	100	W
T _j	Junction temperature		150	□
T _{stg}	Storage temperature		-65~150	□

THERMAL CHARACTERISTICS

SYMBOL	PARAMETER	MAX	UNIT
R _{th j-mb}	Thermal resistance from junction to mounting base	1.25	K/W

Silicon NPN Power Transistors

BUW11 BUW11A

CHARACTERISTICS

T_j=25 °C unless otherwise specified

SYMBOL	PARAMETER		CONDITIONS	MIN	TYP.	MAX	UNIT
V _{CEO(SUS)}	Collector-emitter sustaining voltage	BUW11	I _C =0.1A ; I _B =0; L=25mH	400			V
		BUW11A		450			
V _{CEsat}	Collector-emitter saturation voltage	BUW11	I _C =3A; I _B =0.6A			1.5	V
		BUW11A	I _C =2.5A; I _B =0.5A				
V _{BEsat}	Base-emitter saturation voltage	BUW11	I _C =3A; I _B =0.6A			1.4	V
		BUW11A	I _C =2.5A; I _B =0.5A				
I _{CES}	Collector cut-off current		V _{CE} =Rated V _{CEs} ; V _{BE} =0 T _j =125 °C			1.0 2.0	mA
I _{EBO}	Emitter cut-off current		V _{EB} =9V; I _C =0			10	mA
h _{FE-1}	DC current gain		I _C =5mA ; V _{CE} =5V	10		35	
h _{FE-2}	DC current gain		I _C =0.5A ; V _{CE} =5V	10		35	

Switching times resistive load

t _{on}	Turn-on time	For BUW11F I _C =3A ; I _{B1} =-I _{B2} =0.6A For BUW11AF I _C =2.5A ; I _{B1} =-I _{B2} =0.5A			1.0	μs
t _s	Storage time				4.0	μs
t _f	Fall time				0.8	μs

Silicon NPN Power Transistors

BUW11 BUW11A

PACKAGE OUTLINE

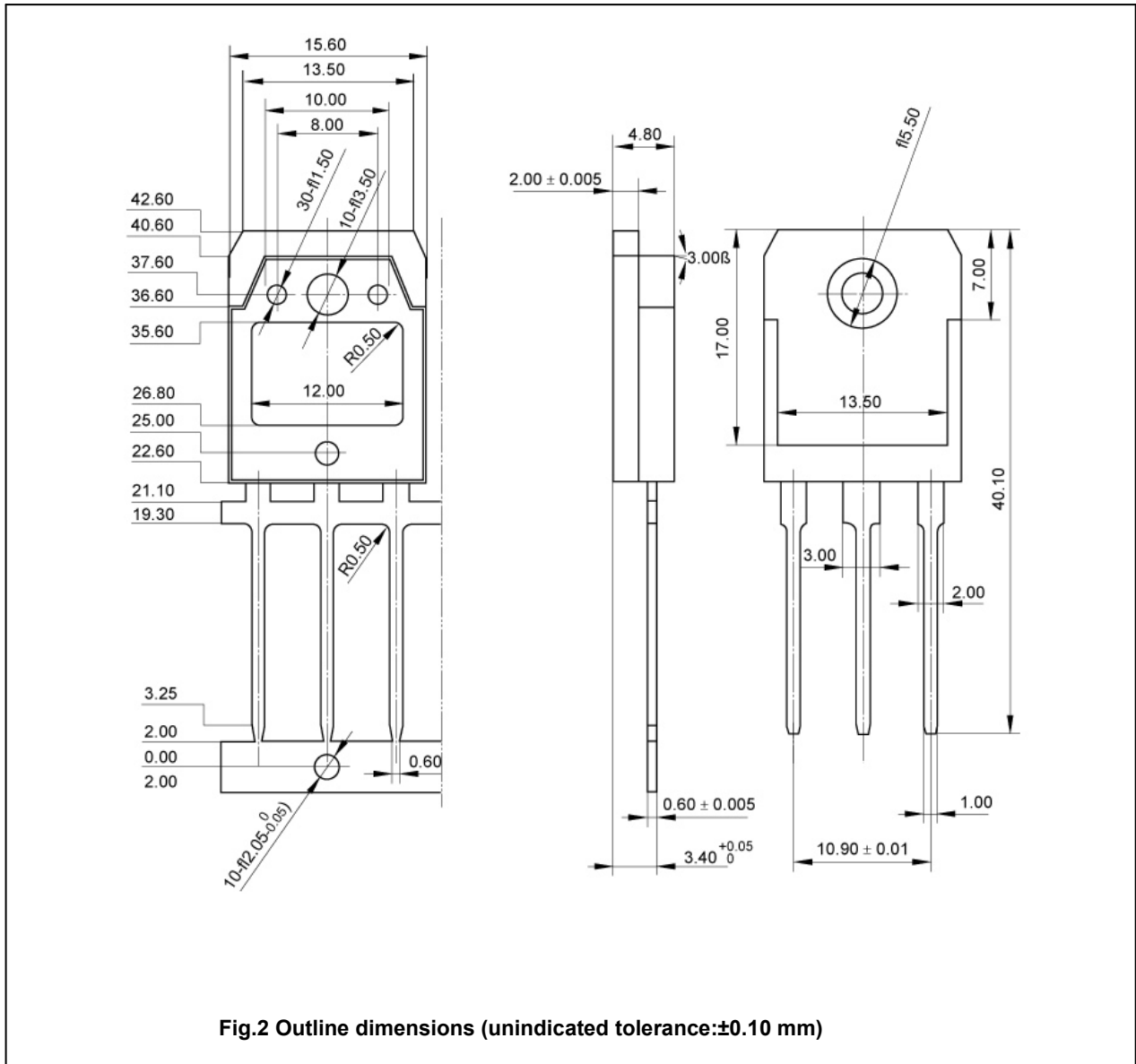

Fig.2 Outline dimensions (unindicated tolerance: ± 0.10 mm)