

Drop-In

Monolithic Amplifier

0.05-1 GHz

Product Features

- Equivalent to Agilent MSA-1104
- High IP3, 34 dBm
- Excellent VSWR, 1.2:1 typ.
- Medium gain
- Output power, 18.2 dBm



MAV-11+

CASE STYLE: BBB123
PRICE: \$1.57 ea. QTY. (30)

Typical Applications

- Cellular
- UHF/VHF receivers/transmitters

+RoHS Compliant

The +Suffix identifies RoHS Compliance. See our web site for RoHS Compliance methodologies and qualifications

General Description

MAV-11+ (RoHS compliant) is a wideband amplifier offering high dynamic range. It has repeatable performance from lot to lot. It is enclosed in a plastic molded package. MAV-11+ uses Darlington configuration and is fabricated using silicon technology. Expected MTBF is 500 years at 85°C case temperature.

simplified schematic and pin description

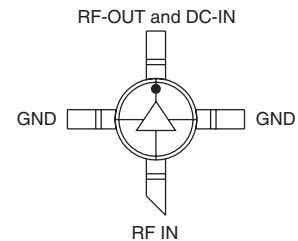
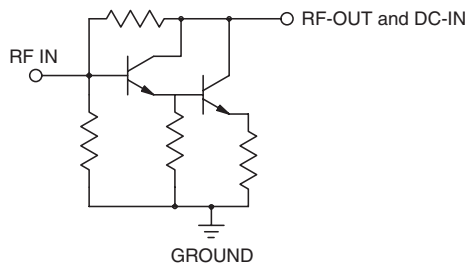

Function	Pin Number	Description
RF IN	1	RF input pin. This pin requires the use of an external DC blocking capacitor chosen for the frequency of operation.
RF-OUT and DC-IN	3	RF output and bias pin. DC voltage is present on this pin; therefore a DC blocking capacitor is necessary for proper operation. An RF choke is needed to feed DC bias without loss of RF signal due to the bias connection, as shown in "Recommended Application Circuit".
GND	2,4	Connections to ground. Use via holes as shown in "Suggested Layout for PCB Design" to reduce ground path inductance for best performance.

Notes

- Performance and quality attributes and conditions not expressly stated in this specification document are intended to be excluded and do not form a part of this specification document.
- Electrical specifications and performance data contained in this specification document are based on Mini-Circuit's applicable established test performance criteria and measurement instructions.
- The parts covered by this specification document are subject to Mini-Circuits standard limited warranty and terms and conditions (collectively, "Standard Terms"); Purchasers of this part are entitled to the rights and benefits contained therein. For a full statement of the Standard Terms and the exclusive rights and remedies thereunder, please visit Mini-Circuits' website at www.minicircuits.com/MCLStore/terms.jsp



Electrical Specifications at 25°C and 60mA, unless noted

Parameter	Min.	Typ.	Max.	Units
Frequency Range*	0.05		1	GHz
Gain	f=0.1 GHz f=1 GHz	12.7 9.0 ²	10.5	dB
Input Return Loss	f=0.05 to 1 GHz	14		dB
Output Return Loss	f=0.05 to 1 GHz	11.5		dB
Output Power @ 1 dB compression	f=0.5 GHz	+17.5		dBm
Output IP3	f=0.5 GHz	+30		dBm
Noise Figure	f=0.5 GHz	3.6		dB
Recommended Device Operating Current		60		mA
Device Operating Voltage		5.5		V
Thermal Resistance, junction-to-case ¹		125		°C/W

*Guaranteed specification 0.05-1 GHz. Low frequency cut off determined by external coupling capacitors.

Absolute Maximum Ratings

Parameter	Ratings
Operating Temperature*	-20°C to 85°C
Storage Temperature	-55°C to 100°C
Operating Current	80mA
Power Dissipation	550mW
Input Power	13dBm

Note: Permanent damage may occur if any of these limits are exceeded. These ratings are not intended for continuous normal operation.

¹Case is defined as ground leads.
²Full operating temperature range

Notes

- A. Performance and quality attributes and conditions not expressly stated in this specification document are intended to be excluded and do not form a part of this specification document.
- B. Electrical specifications and performance data contained in this specification document are based on Mini-Circuit's applicable established test performance criteria and measurement instructions.
- C. The parts covered by this specification document are subject to Mini-Circuits standard limited warranty and terms and conditions (collectively, "Standard Terms"); Purchasers of this part are entitled to the rights and benefits contained therein. For a full statement of the Standard Terms and the exclusive rights and remedies thereunder, please visit Mini-Circuits' website at www.minicircuits.com/MCLStore/terms.jsp



Product Marking

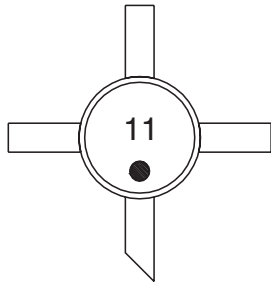

Additional Detailed Technical Information

Additional information is available on our web site. To access this information enter the model number on our web site home page.

Performance data, graphs, s-parameter data set (.zip file)

Case Style: BBB123

Plastic molded package, .145 body diameter, lead finish: tin

Tape & Reel: F11

Suggested Layout for PCB Design: N/A

Evaluation Board: N/A

Environmental Ratings: ENV08

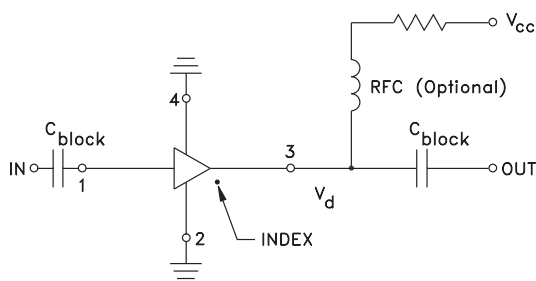

R BIAS	
Vcc	"1%" Res. Values (ohms) for Optimum Biasing
7	28.0
8	45.3
9	61.9
10	78.7
11	95.3
12	113
13	127
14	143
15	158

Notes

- A. Performance and quality attributes and conditions not expressly stated in this specification document are intended to be excluded and do not form a part of this specification document.
- B. Electrical specifications and performance data contained in this specification document are based on Mini-Circuit's applicable established test performance criteria and measurement instructions.
- C. The parts covered by this specification document are subject to Mini-Circuits standard limited warranty and terms and conditions (collectively, "Standard Terms"); Purchasers of this part are entitled to the rights and benefits contained therein. For a full statement of the Standard Terms and the exclusive rights and remedies thereunder, please visit Mini-Circuits' website at www.minicircuits.com/MCLStore/terms.jsp

ESD Rating

Human Body Model (HBM): Class 0 (< 250 v) in accordance with ANSI/ESD STM 5.1 - 2001

Charged Device Model (CDM): Class III (500v to 1000 v) in accordance with JESD22-C101C

MSL Rating

Moisture Sensitivity: MSL1 in accordance with IPC/JEDECJ-STD-020C

No.	Test Required	Condition	Standard	Quantity
1	Visual Inspection	Low Power Microscope Magnification 40x	MIP-IN-0003 (MCT spec)	20 units
2	Electrical Test	Room Temperature	SCD (MCL spec)	20 units
3	SAM Analysis	Less than 10% growth in term of delamination	J-Std-020C (Jedec Standard)	20 units
4	Moisture Sensitivity Level 1	Bake at 125°C for 24 hours Soak at 85°C/85%RH for 168 hours Reflow 3 cycles at 260°C peak	J-Std-020C (Jedec Standard)	20 units

MSL Test Flow Chart

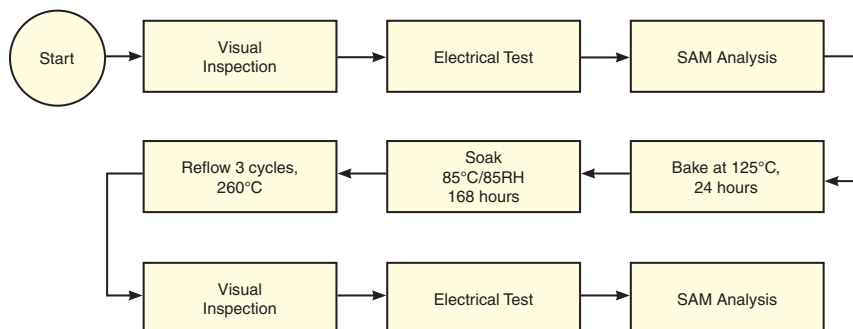

Notes

- A. Performance and quality attributes and conditions not expressly stated in this specification document are intended to be excluded and do not form a part of this specification document.
- B. Electrical specifications and performance data contained in this specification document are based on Mini-Circuit's applicable established test performance criteria and measurement instructions.
- C. The parts covered by this specification document are subject to Mini-Circuits standard limited warranty and terms and conditions (collectively, "Standard Terms"); Purchasers of this part are entitled to the rights and benefits contained therein. For a full statement of the Standard Terms and the exclusive rights and remedies thereunder, please visit Mini-Circuits' website at www.minicircuits.com/MCLStore/terms.jsp

