

### Featuring the Sil I364 Panellink Transmitter

The I364ADD2 PCI Express Digital Display card, a production-ready reference card by Silicon Image, is a low-cost solution that brings the Digital Visual Interface (DVI) to any Intel 915G-based desktop PC with a PCI Express slot. The I364ADD2 card provides a simple add-in solution that connects into the PCI Express slot of any 915G motherboard with full hardware and software compatibility.

Equipped with the Silicon Image Sil I364 DVI transmitter chip, the I364ADD2 card provides PC and motherboard manufacturers a low-cost, all-digital video interface covering the full range of digital display resolutions from VGA to UXGA. Flat panel displays, digital projectors and digital CRTs are all supported by this card. Incorporating PanelLink® technology — Silicon Image's proprietary implementation of the DVI specification — the Sil I364 is the market's leading DVI-compliant transmitter capable of running at the full 5 Gbps single-link bandwidth.

Using the I364ADD2 card is seamless and easy. With a small board size and the choice of a standard or low-profile PCI Express bracket, the card can be universally installed in

any PC form factor. Simply insert it into the x16 PCI Express slot of any Intel 915G-equipped motherboard, and the PC is now fully DVI-ready. Upon boot up, the system automatically loads the ADD2 card configuration information (stored in a serial EEPROM) and configures the outputs to the PCI Express pins with Intel's x4 lane SDVO (Serial Digital Video Output) interface. The configuration information file in Serial Presence Detect (SPD) format software for the I364ADD2 card is fully tested, certified and provided by Silicon Image and Intel.

The I364ADD2 card turns any Intel 915G-based PC into a high-performance, DVI-compliant system capable of supporting high-resolution digital displays. Fully hardware and software qualified, the I364ADD2 card reference design can be brought to volume production quickly.

Contact Silicon Image to order your I364ADD2 Starter Kit, which includes the reference board sample and documentation. Go digital today — because digital is better.

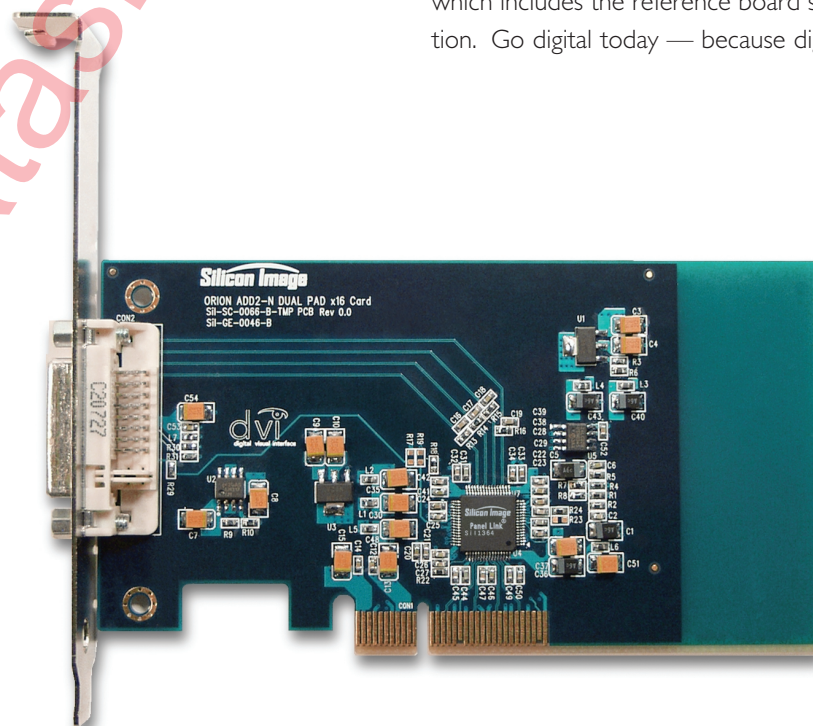
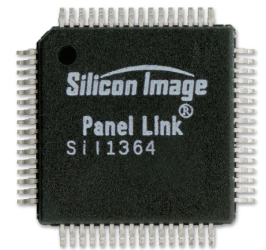

## Featuring the Sil I364 Panellink Transmitter

## I364ADD2 Card Features

### Applications

- Desktop motherboards using Intel 915G graphics chipset with a x16 PCI Express slot

### Panellink® Transmitter

- Silicon Image Sil I364 DVI transmitter
- 25-165 MHz DVI-compliant bandwidth
- Industry-leading DVI-compliant solution

### Input

- x4 lane Serial Digital Video Output (SDVO) over x16 PCI Express connector slot

### Output

- DVI-D digital connector
- Single-link TMDS® & DDC compliant with the DVI 1.0 standard
- Supports VGA-UXGA resolution DVI-compliant displays

### Physical Mounting

- Standard height or low-profile PCI Express bracket
- 2.6" x 5" card profile

### Easy to Use

- Includes tested configuration information code stored in serial EEPROM
- Fully software compatible with all Intel 915G BIOS and drivers
- Tested and qualified for FCC regulatory requirements (reports available upon request)

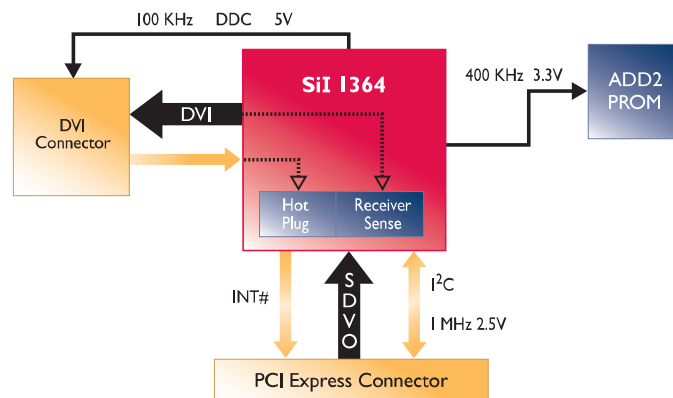

## Silicon Image's I364ADD2 Starter Kit

The CP1364ADD2-N/CP1364ADD2-R I364 DVI Starter Kit includes all the hardware, software and documentation to quickly bring a DVI ADD2 system to production.

### Contents include:

#### Hardware

- ADD2-N/ADD2-R card with PCI Express gold finger connector and retention mechanism
- DVI-D single link output connector
- Serial EEPROM (stores configuration information)

#### Software

- Configuration information code
- Gerber and layout files available upon request

#### Documentation

- Starter Kit User's Guide
- Sil I364 Data Sheet
- Reference schematics

## The Panellink Advantage

Silicon Image's Panellink TMDS technology was selected by DDWG founders Intel, Compaq, Fujitsu, Hewlett Packard, IBM and NEC to serve as the technical foundation for the DVI standard.

All Panellink parts are tested at full speed for guaranteed DVI compatibility. With more than 40 million Panellink solutions shipped to the PC/display market alone, Panellink is the world's leading DVI implementation.

### Part Numbers:

#### Non-Lane Reversed Applications (typical for ATX motherboards)

- I364DVIADD2-N (Card only)
- CP1364ADD2-N (Starter Kit)

#### Lane Reversed Applications (typical for BTX motherboards)

- I364DVIADD2-R (Card only)
- CP1364ADD2-R (Starter Kit)