

QuickSpecs

HP Smart Array P400 Controller

Overview

The HP Smart Array P400 is HP's first PCI-Express (PCIe) serial attached SCSI (SAS) RAID controller and provides new levels of performance and reliability for HP servers, through its support of 3Gb/s SAS technology and advanced RAID capabilities.

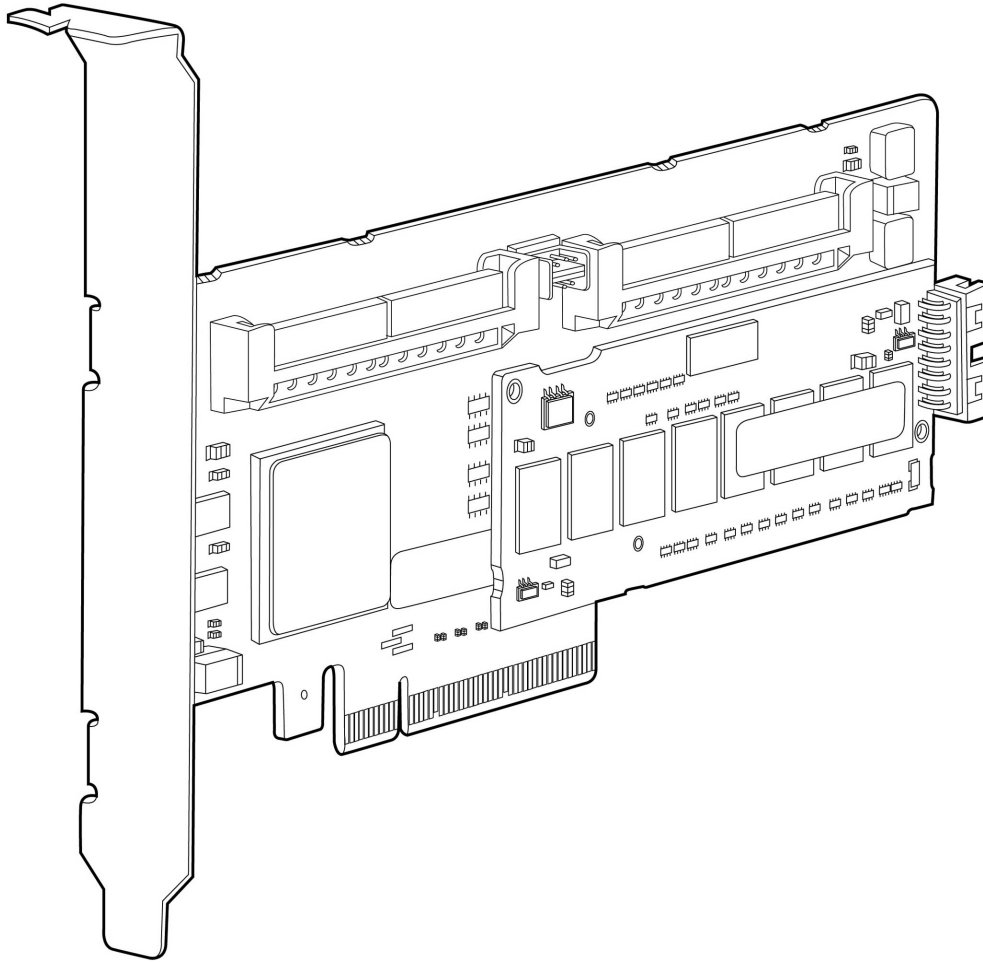

What's New

- Updating supported hard drives.

Models

HP Smart Array P400 Controller	HP Smart Array P400/256 2-ports Int PCIe x8 SAS Controller	405132-B21
	HP Smart Array P400 512MB Battery Kit	411064-B21



QuickSpecs

HP Smart Array P400 Controller

Standard Features

The Smart Array Advantage

HP's innovative design and integration work of the Smart Array family of products creates customer value that is unmatched in the industry. Use of Smart Array products across multiple applications results in a much lower Total Cost of Ownership (TCO) than any other server storage RAID product. The HP Smart Array family brings an unparalleled return on investment through:

Data Compatibility among all models of Smart Array controllers allows simple and easy upgrades any time needs for higher performance, capacity, and availability increase. Even successive generations of Smart Array controllers understand the data format of other Smart Array Controllers.

Consistent Configuration and Management Tools. All Smart Array products utilize a standard set of management and utility software. These tools minimize Total Cost of Ownership (TCO) by reducing training requirements and technical expertise necessary to install and maintain the HP server storage.

Universal Hard Drive form factor is for use across multiple HP servers, disk enclosures and storage systems. With compatibility across many enterprise platforms, you are free to deploy and re-deploy these drives to quickly deliver increased storage capacity, migrate data between systems, and easily manage spare drives.

Pre-Failure Warranty means HP Insight Manager not only reports when a drive is going to fail but allows replacement of failing drives prior to actual failure. For complete details, consult the HP Support Center or refer to your HP Server documentation.

Key Features

- The SA-P400 Controller supports up to 18 drives depending on the server implementation. The SA-P400i Controller supports up to 6 drives depending on the server implementation
- Seamless upgrades from past generations and upgrades to next generation HP high performance and high capacity Serial Attached SCSI Smart Array controllers.
- 3G SAS technology delivers high performance and data bandwidth up to 300 MB/s per physical link and contains full compatibility with 1.5G SATA technology.
- x8 2.5G PCI Express host interface technology delivers high performance and data bandwidth up to 2 GB/s maximum bandwidth.
- Modular, easy-to-upgrade design lets you optimize performance by upgrading from 40-bit 256MB cache to 72-bit 512MB battery-backed write cache (BBWC).
- Addition of the battery backed cache upgrade enables BBWC, RAID 6 with ADG, array expansion, logical drive extension, RAID migration, and stripe size migration.
- Mix-and-match SAS and SATA hard drives, lets you deploy drive technology as needed to fit your computing environment.
- Software consistency among all Smart Array family products: Array Configuration Utility (ACU), Option ROM Configuration for Arrays (ORCA), Systems Insight Manager, Array Diagnostic Utility (ADU) and SmartStart.
- Support for greater than 2TB in a single logical drive.
- Low-profile PCI Express form factor - ships with a full size bracket for deployment in either a low-profile or full sized slot.



QuickSpecs

HP Smart Array P400 Controller

Standard Features

Management Features

- Online array expansion (with BBWC upgrade)
- Online logical drive extension (with BBWC upgrade)
- Online RAID level migration (with BBWC upgrade)
- Online strip size migration (with BBWC upgrade)
- Offline Mirror splitting and recombining
- Unlimited global online spare assignment
- User selectable expand and rebuild priority
- User selectable RAID level and stripe size
- User selectable read and write cache sizes

Ports

- Eight (8) SAS physical links distributed across 2 internal x4 wide port connectors.

Performance

HP's High Performance Architecture sets new boundaries of industry performance expectations!

- 3Gb/s SAS (300MB/s bandwidth per physical link)
- x8 3Gb/s SAS physical links (compatible with 1.5G SATA)
- 256 MB 40-bit wide DDR2-533MHz cache upgradeable to 512 MB 72-bit wide DDR2-533MHz battery-backed cache provides up to 4.2 GB/s maximum bandwidth
- x8 2.5G PCI Express host interface provides 2 GB/s maximum bandwidth
- 440 PowerPC Processor
- Read ahead caching
- Write-back caching (with battery-backed write cache upgrade)

Native Command Queuing

Native Command Queuing (NCQ) is a technology designed to increase performance of SATA hard disk drives by allowing the individual hard disk to internally optimize the order in which received read and write commands are executed. This can reduce the amount of unnecessary going back-and-forth on the drive's heads, resulting in increased performance for workloads where multiple simultaneous read/write requests are outstanding, most often occurring in server or storage-type applications. Without NCQ the drive has to process and complete one command at a time. For NCQ to be enabled, it must be supported and turned on in the controller and in the hard drive itself.

NOTE: Please see the [SATA Hard Drive QuickSpecs](http://h18000.www1.hp.com/products/quickspecs/11940_div/11940_div.html) for specific SATA hard drive capacities that support NCQ: http://h18000.www1.hp.com/products/quickspecs/11940_div/11940_div.html

Dual Domain Support

Dual domain SAS creates redundant pathways for external drives from servers to storage devices. The redundant paths created by these configurations reduce or eliminate single points of failure within the storage network. This provides increased levels of high availability with redundant paths from the controller to the drives. Dual domain SAS implementations make it possible to tolerate host bus adapter (HBA) or controller failure, external cable failure, expander failure, cable pulls, expander failure and failure in a spanned disk (JBOD) environments.

Capacity

Given the increasing need for high performance and rapid capacity expansion, the SA-P400 Controller offers:

- Up to 38TB of total storage with 38 x 1TB 3.5" SATA MDL HDD



QuickSpecs

HP Smart Array P400 Controller

Standard Features

Availability

Provides increased server uptime by providing advanced storage functionality:

- Online RAID level migration (between any RAID level)
 - Online stripe size migration
 - Online array expansion
 - Online logical drive extension
 - Online drive firmware upgrade
 - Unlimited global online spare
 - Pre-Failure Warranty
-

Fault Prevention

The following features offer detection of possible failures before they occur, allowing preventive action to be taken:

- S.M.A.R.T.: Self Monitoring Analysis and Reporting Technology first developed at HP detects possible hard disk failure before it occurs, allowing replacement of the hard drive before a real failure occurs.
 - Drive Parameter Tracking monitors drive operational parameters, predicting failure and notifying the administrator.
 - Dynamic Sector Repairing continually performs background surface scans on the hard disk drives during inactive periods and automatically remaps bad sectors, ensuring data integrity.
 - Smart Array Cache Tracking monitors integrity of controller cache, allowing pre-failure preventative maintenance.
-

Fault Tolerance

Keeps data available and server running while a failed drive is being replaced; several fault tolerance configurations are supported including:

- **RAID 6 with ADG** (Advanced Data Guarding): This is the highest level of fault tolerance. It allocates two sets of parity data across drives and allows simultaneous write operations. This level of fault tolerance can withstand two simultaneous drive failures without downtime or data loss.
 - **RAID 5** (Distributed Data Guarding): This allocates one set of parity data across drives and allows simultaneous write operations. This level of fault tolerance can withstand a single drive failure without downtime or data loss.
 - **RAID 1, 1+0** (Drive Mirroring): This allocates half of the drive array to data and the other half to mirrored data, providing two copies of every file. It is a high-performance RAID.
-

Fault Recovery

Minimizes downtime, reconstructs data, and facilitates a quick recovery from drive failure

- Recovery ROM: This feature protects the user from a firmware image corruption by storing a redundant copy of the firmware image. If the active firmware image becomes corrupt, the controller will use the redundant firmware image and continue operating.
 - On-Line Spares: There is no limit to the number of spare drives that can be installed prior to drive failure. If a failure occurs, recovery begins with an On-Line Spare and data is reconstructed automatically.
 - DRAM ECC detects and corrects data bit errors.
 - Battery-backed write cache upgrade provides for up to two days of battery power for data cache retention. The data backup duration could be extended anytime the server's auxiliary power is available during system power down.
-



QuickSpecs

HP Smart Array P400 Controller

Standard Features

Ease of Use

Consistency and Upgradeability make the Smart Array family unique in the industry:

- GUI based configuration, management and diagnostic software tools
 - Common data format between generations of products
 - Data migration between servers and external Modular Smart Array enclosures
-

Warranty

The warranty for this device is 3 years parts, labor and onsite.

Pre-Failure Warranty: Drives attached to the Smart Array Controller and monitored under Insight Manager are supported by a Pre-Failure (replacement) Warranty. For complete details, consult the HP Support Center or refer to your HP Server Documentation.

Warranty Upgrade Options

- Response - Upgrade on-site response from next business day to same day 4 hours
- Coverage - Extend hours of coverage from 9 hours x 5 days to 24 hours x 7 days
- Duration - Select duration of coverage for a period of 1, 3, or 5 years
- Warranty upgrade options can come in the form of Care Packs, which are sold at the HP System level this product attaches too



Compatibility

Server Compatibility For up to date compatibility, please see the following URL for complete Smart Array P400 Controller compatibility and support information:
<http://h18006.www1.hp.com/products/servers/proliantstorage/arraycontrollers/index.html>

Operating Systems

- Microsoft® Windows™ 2000 Server
- Microsoft Windows 2000 Advanced Server
- Microsoft Windows 2003 / R2 Standard Edition
- Microsoft Windows 2003 / R2 Enterprise Edition
- Microsoft Windows 2003 / R2 Standard x64 Edition
- Microsoft Windows 2003 / R2 Enterprise x64 Edition
- Microsoft Windows 2003 / R2 SBS
- Microsoft Windows 2008 Server
- Novell Open Enterprise Server, NetWare 6.5 SP5
- Red Hat Enterprise Linux
- SUSE Linux Enterprise Server
- SCO OpenServer 5.0.7, 6
- SCO UnixWare 7.1.3, 7.1.4
- Solaris 10
- VMWare ESX 3.0

NOTE: For more Linux OS support & certification information, please visit our the ProLiant & BladeSystem Server Linux matrix: <http://h18004.www1.hp.com/products/servers/linux/hplinuxcert.html>

Software Suite All Smart Array products share a common set of configuration, management and diagnostic tools, including Array Configuration Utility, Array Diagnostic Utility (ADU), and Systems Insight Manager. This software consistency of tools reduces the cost of training for each successive generation of product and takes much of the guesswork out of troubleshooting field problems. These tools lower the total cost of ownership by reducing training and technical expertise necessary to install and maintain HP server storage.

Systems Insight Manager

- Powerful server and server options/storage manager tool
- Monitors over 1200 system wide parameters
- Configuration/Diagnostic Utilities

HP Array Configuration Utility (ACU)

- Powerful Web based configuration utility for all Smart Array controllers
- Provides a graphical view of HP drive array configurations
- Allows for management of multiple arrays over a secure internet connection from anywhere in the world
- Easy to use Wizards for configuration
- Runs offline for all supported Operating Systems and runs online for Windows and Linux. For online configuration of NetWare, use CPQONLIN

HP Option ROM Configuration for Arrays (ORCA)



QuickSpecs

HP Smart Array P400 Controller

Compatibility

- A simple method for managing logical drives during system power up by pressing F8 during POST
- Allows the ability to create arrays, logical drives, and assign an online spare drive
- Allows the ability to view and delete logical drives
- Allows the ability to select the boot controller
- For advanced array configurations use ACU

HP Array Diagnostic Utility (ADU)

- In depth diagnostic and reporting utility for all Smart Array controllers
- Runs offline for all supported Operating Systems, and runs online for Windows and Linux



Service and Support

Service and Support

HP Care Pack Services: Packaged server and storage services for increased uptime, productivity and ROI

When you buy HP server and storage products and solutions, it's also a good time to think about what levels of support you may need. Our portfolio of service options reduce deployment and management worries while helping you get the most out of your server and storage investments. We take a holistic approach to your environment, bridging servers, blades, storage, software and network infrastructures with our packaged HP Care Pack Services for servers and storage.

Protect your business beyond warranty

When it comes to robustness and reliability, standard computing equipment warranties have matured along with technology. Good news that can also create problems stemming from depending on standard warranties designed to only protect against product defects and some downtime causes. Using a standard approach to warranty uplifts, such as HP Care Pack Services, helps reduce downtime risks and provides operational consistency for mission-critical and standard business computing.

HP Care Pack Services: Upgrading or extending standard server and storage warranties cost effectively

HP Care Pack Services offer a standard reactive hardware and software support services suite sold separately, or combined with our Support Plus and Support Plus 24 services. The portfolio also provides a combination of integrated proactive and reactive services, such as Proactive 24 Service and Critical Service. In addition with HP Proactive Select, you can acquire the specific proactive constancy and technical services. HP Proactive Select menu offers a broad set of service options that you can mix and match depending on your specific requirements. Proactive service options include offers for server, storage, network, SAN device, software, environment and education services.

HP server and storage lifecycle support services offers a full spectrum of customer care-from technology support to complex migrations to complete managed services. HP Factory Express provides customization, integration and deployment services for turnkey solutions. HP Education Services offer flexible, comprehensive training on to help your IT staff get the most out of your server and storage investments. HP Financial solutions extend innovative financing and cost-effective asset management programs-from purchase to equipment retirement.

Learn more: www.hp.com/services/servers and www.hp.com/services/storage

NOTE: Care Pack Services availability may vary by product and country.

HP Care Pack Services are sold by HP and HP Authorized Service Partners:

- Services for customers purchasing from HP or an enterprise reseller are quoted using HP order configuration tools.
- Customers purchasing from a commercial reseller can find HP Care Pack Services at <http://www.hp.com/go/lookuptool>



Service and Support

Recommended HP Care Pack Services for optimal satisfaction with your HP product

Recommended Services **Hardware Options Support**

HP Care Packs provide support for all HP-branded hardware options qualified for inclusion in your server or storage solution. Any additional HP-qualified options installed within the server are covered at the same service level and for the same period as the server and no additional cost.

- Help improve or maintain system uptime
- Convenient onsite support
- Committed response time

<http://h20195.www2.hp.com/V2/GetPDF.aspx/5982-6547EEE>

3-Year HP Hardware Support Onsite Service, 4-hour response, 24x7

Provides you with rapid remote support and if required an HP authorized representative who will arrive on site any time and day of the year to begin hardware maintenance service within 4 hours of the service request being logged.

This service provides a trained HP service specialist to perform an installation that meets HP quality standards, for:

- " Help improve or maintain system uptime
- " Convenient onsite support
- " Committed response time

<http://h20195.www2.hp.com/V2/GetPDF.aspx/5982-6547EEE>

HP Installation and Startup of HP ProLiant Servers

Provides for the installation of your new HP ProLiant server and operating system to assist you in bringing your new HP ProLiant server and operating system into operation in a timely and professional manner.

This service provides a trained HP service specialist to perform an installation that meets HP quality standards, for:

- Delivery of the service at a mutually scheduled time convenient to your organization
- Availability of an HP service specialist to answer basic questions during the onsite delivery of this service
- Custom installation as detailed in "Delivery specifications" or in a Statement of Work (SOW)
- Verification prior to installation that all service prerequisites are met

<http://h20195.www2.hp.com/V2/GetPDF.aspx/5982?7572ENN>



Service and Support

Optional HP Care Pack Services that will enhance your HP product experience

Optional Services

3-Year HP Hardware Support Onsite Call-to-Repair (CTR) Service, 6- or 24-hour

As an alternative to our recommended support level, for customers who need committed call-to-repair for server hardware.

Provides your IT manager with a team of support specialists who will quickly begin troubleshooting the system to help return the hardware to operating condition within 6 or 24 hours of the initial service request to the HP Global Solution Center.

<http://h20195.www2.hp.com/V2/GetPDF.aspx/5981-6636ENN>

3-Year HP Support Plus 24

As an alternative to our recommended support level, for customers who need access to responsive 24x7 hardware and software support plus software updates on HP and selected third party products:

For a higher return on your server and storage technology, our 3-year combined reactive support service delivers integrated onsite hardware/software support services available 24x7x365, including access to HP technical resources, 4-hour response onsite hardware support and software updates.

<http://h20195.www2.hp.com/V2/GetPDF.aspx/5982-6547EN.pdf>

HP Proactive Select Service

Customer needs on demand access to consulting, technical proactive services and education courses

Provides a flexible way to purchase HP best-in-class consultancy and technical services. You can buy Proactive Select Service Credits when you purchase your hardware and then use the credits over the next 12 months.

<http://h20195.www2.hp.com/V2/GetPDF.aspx/4AA2-3842ENN>

eSupport

HP eSupport is a portfolio of technology-based services that assist you with managing your business environment - from the desktop to the data center.

Support Portal

The HP support portal provides one-stop access to the information, tools and services you need to manage the daily operations of your IT environment.

Features include:

- Access to self-solve tools (including search technical knowledge base)
- Efficient logging and tracking of support cases
- Collaboration with other business and IT professionals
- Download of patches and drivers
- Access to diagnostic tools
- Proactive notification of relevant information

Access to certain features of the support portal requires an HP service agreement. To access the support portal, visit: <http://www.hp.com/support>

HP Insight Remote Support software delivers secure remote support for your HP Servers and Storage, 24



QuickSpecs

HP Smart Array P400 Controller

Service and Support

X 7, so you can spend less time solving problems and more time focused on your business. You can have your systems remotely monitored for hardware failure using secure technology that's been proven at thousands of companies around the world. In many cases, you can avoid problems before they occur.

Customer Technical Training

In today's cost-conscious business environment, IT professionals, developers, consultants and users face an interesting challenge: how to keep up with the latest technologies and expand important skills while delivering profitable results on current projects. To help address this challenge, HP offers innovative training solutions that help keep you up-to-date on virtualization, server, storage, Insight Control, Citrix, Microsoft® and open source/Linux-related topics-while spending less time away from business-critical activities.

HP Services Awards

HP Technology Services continues to be recognized for service and support excellence by customers, partners, industry organizations and publications around the world. Recent honors and award reflect our services team's dedications, technical expertise, professionalism and uncompromising commitment to customer satisfaction.

Additional Services Information

To learn more on HP ProLiant servers, HP BladeSystem servers and HP storage products, please contact your HP sales representative or HP Authorized Channel Partner. Or visit: www.hp.com/services/proliant or www.hp.com/services/bladeSystem or <http://www.hp.com/hps/storage>



QuickSpecs

HP Smart Array P400 Controller

Related Options

NOTE: This is a list of supported options. Some may be discontinued.

HP Battery Attach Kit	HP Smart Array P400 Battery Attach Kit NOTE: This option kit contains a 24" battery cable and adhesive material for installing a battery into the following servers if a Smart Array P400 is integrated outside of the factory - HP ProLiant ML310 G3, HP ProLiant ML310 G4, HP ProLiant DL320 G4, HP ProLiant DL320 G5, HP ProLiant DL320s, HP ProLiant ML350 G5, HP ProLiant DL380 G5 (installations in a full size slot), HP ProLiant DL385 G2 (installations in a full size slot) and HP ProLiant DL580 G4. For all solutions, please refer to the HP ProLiant QuickSpecs and User's Manual for detailed installation instructions.	417836-B21
HP Cache Upgrades	HP Smart Array Cache Battery Kit HP 512MB w/Battery Smart Array Battery Back Write Cache Enabler	383280-B21 405148-B21
HP Hard Drives	SAS Hot Plug SFF (2.5-inch) Enterprise (ENT) Drives HP 900GB 6G SAS 10K rpm SFF (2.5-inch) Dual Port Enterprise 3yr Warranty Hard Drive HP 600GB 6G SAS 10K rpm SFF (2.5-inch) Dual Port Enterprise 3yr Warranty Hard Drive HP 450GB 6G SAS 10K rpm SFF (2.5-inch) Dual Port Enterprise 3yr Warranty Hard Drive HP 300GB 6G SAS 10K rpm SFF (2.5-inch) Dual Port Enterprise 3yr Warranty Hard Drive HP 300GB 3G SAS 10K rpm SFF (2.5-inch) Dual Port Enterprise 3yr Warranty Hard Drive HP 146GB 6G SAS 15K rpm SFF (2.5-inch) Dual Port Enterprise 3yr Warranty Hard Drive HP 146GB 3G SAS 15K rpm SFF (2.5-inch) Dual Port Enterprise 3yr Warranty Hard Drive HP 146GB 6G SAS 10K rpm SFF (2.5-inch) Dual Port Enterprise 3yr Warranty Hard Drive HP 146GB 3G SAS 10K rpm SFF (2.5-inch) Dual Port Enterprise 3yr Warranty Hard Drive HP 72GB 6G SAS 15K rpm SFF (2.5-inch) Dual Port Enterprise 3yr Warranty Hard Drive HP 72GB 3G SAS 15K rpm SFF (2.5-inch) Dual Port Enterprise 3yr Warranty Hard Drive HP 146GB 10K rpm Hot Plug SAS 2.5 Single Port Hard Drive HP 72GB 15K rpm Hot Plug SAS 2.5 Single Port Hard Drive HP 72GB 10K rpm Hot Plug SAS 2.5 Dual Port Hard Drive HP 72GB 10K rpm Hot Plug SAS 2.5 Hard Drive HP 36GB 15K rpm Hot Plug SAS 2.5 Dual Port Hard Drive HP 36GB 15K rpm Hot Plug SAS 2.5 Single Port Hard Drive SAS Non-Hot Plug SFF (2.5-inch) Enterprise (ENT) Drives HP 600GB 6G SAS 10K rpm SFF (2.5-inch) Non-hot Plug Dual Port Enterprise 3yr Warranty Hard Drive	619291-B21 581286-B21 581284-B21 507127-B21 492620-B21 512547-B21 504062-B21 507125-B21 418367-B21 512545-B21 418371-B21 431958-B21 431935-B21 384842-B21 375861-B21 418369-B21 431933-B21 590698-B21



QuickSpecs

HP Smart Array P400 Controller

Related Options

HP 300GB 6G SAS 10K rpm SFF (2.5-inch) Non-hot Plug Dual Port Enterprise 3yr Warranty Hard Drive	537809-B21
HP 146GB 6G SAS 10K rpm SFF (2.5-inch) Non-hot Plug Dual Port Enterprise 3yr Warranty Hard Drive	537807-B21
HP 72GB 6G SAS 15K rpm SFF (2.5-inch) Non-hot Plug Dual Port Enterprise 3yr Warranty Hard Drive	537805-B21
SAS Hot Plug LFF (3.5-inch) Enterprise (ENT) Drives	
HP 600GB 6G SAS 15K rpm LFF (3.5-inch) Dual Port Enterprise 3yr Warranty Hard Drive	516828-B21
HP 450GB 6G SAS 15K rpm LFF (3.5-inch) Dual Port Enterprise 3yr Warranty Hard Drive	516816-B21
HP 450GB 3G SAS 15K rpm LFF (3.5-inch) Dual Port Enterprise 3yr Warranty Hard Drive	454232-B21
HP 400GB 10K rpm Hot Plug SAS 3.5 Dual Port Enterprise Hard Drive	459508-B21
HP 300GB 15K rpm Hot Plug SAS 3.5 Single Port Hard Drive	431944-B21
HP 300GB 6G SAS 15K rpm LFF (3.5-inch) Dual Port Enterprise 3yr Warranty Hard Drive	516814-B21
HP 300GB 3G SAS 15K rpm LFF (3.5-inch) Dual Port Enterprise 3yr Warranty Hard Drive	416127-B21
HP 146GB 15K rpm Hot Plug SAS 3.5 Single Port Hard Drive	375872-B21
HP 146GB 3G SAS 15K rpm LFF (3.5-inch) Dual Port Enterprise 3yr Warranty Hard Drive	384854-B21
HP 72GB 15K rpm Hot Plug SAS 3.5 Single Port Hard Drive	375870-B21
HP 72GB 15K rpm Hot Plug SAS 3.5 Dual Port Hard Drive	384852-B21
SAS Non-Hot Plug LFF (3.5-inch) Enterprise (ENT) Drives	
HP 600GB 6G SAS 15K rpm LFF (3.5-inch) Non-hot Plug Dual Port Enterprise 3yr Warranty Hard Drive	516830-B21
HP 450GB 6G SAS 15K rpm LFF (3.5-inch) Non-hot Plug Dual Port Enterprise 3yr Warranty Hard Drive	516826-B21
HP 450GB 3G SAS 15K rpm LFF (3.5-inch) Non-hot Plug Dual Port Enterprise 3yr Warranty Hard Drive	454234-B21
HP 400GB 10K rpm Non Hot Plug SAS 3.5 Dual Port Enterprise Hard Drive	508232-B21
HP 300GB 6G SAS 15K rpm LFF (3.5-inch) Non-hot Plug Dual Port Enterprise 3yr Warranty Hard Drive	516824-B21
HP 300GB 3G SAS 15K rpm LFF (3.5-inch) Non-hot Plug Dual Port Enterprise 3yr Warranty Hard Drive	417950-B21
HP 300GB 15K rpm Non Hot Plug SAS 3.5 Single Port Hard Drive	431950-B21
HP 146GB 3G SAS 15K rpm LFF (3.5-inch) Non-hot Plug Dual Port Enterprise 3yr Warranty Hard Drive	417855-B21
HP 146GB 15K rpm Non Hot Plug SAS 3.5 Single Port Hard Drive	432093-B21
HP 72GB 15K rpm Non Hot Plug SAS 3.5 Single Port Hard Drive	432095-B21
SAS Hot Plug SFF (2.5-inch) Midline (MDL) Drives	
HP 1TB 6G SAS 7.2K rpm SFF (2.5-inch) Dual Port Midline 1yr Warranty Hard Drive	605835-B21
HP 500GB 6G SAS 7.2K rpm SFF (2.5-inch) Dual Port Midline 1yr Warranty Hard Drive	507610-B21



QuickSpecs

HP Smart Array P400 Controller

Related Options

SAS Hot Plug LFF (3.5-inch) Midline (MDL) Drives

HP 2TB 6G SAS 7.2K rpm LFF (3.5-inch) Dual Port Midline 1yr Warranty Hard Drive	507616-B21
HP 1TB 6G SAS 7.2K rpm LFF (3.5-inch) Dual Port Midline 1yr Warranty Hard Drive	507614-B21
HP 1TB 3G SAS 7.2K rpm LFF (3.5-inch) Dual Port Midline 1yr Warranty Hard Drive	461137-B21
HP 750GB 3G SAS 7.2K rpm LFF (3.5-inch) Dual Port Midline 1yr Warranty Hard Drive	461135-B21

SATA Hot Plug SFF (2.5-inch) Midline (MDL) Drives

HP 1TB 3G SATA 7.2K rpm SFF (2.5-inch) Hot Plug Midline 1yr Warranty Hard Drive	625609-B21
HP 500GB 3G SATA 7.2K rpm SFF (2.5-inch) Midline 1yr Warranty Hard Drive	507750-B21
HP 160GB 3G SATA 7.2K rpm SFF (2.5-inch) Midline 1yr Warranty Hard Drive	530888-B21

SATA Non-Hot Plug SFF (2.5-inch) Midline (MDL) Drives

HP 500GB 3G SATA 7.2K rpm SFF (2.5-inch) Non-hot Plug Midline 1yr Warranty Hard Drive	507753-B21
HP 160GB 3G SATA 7.2K rpm SFF (2.5-inch) Non-hot Plug Midline 1yr Warranty Hard Drive	530891-B21

SATA Hot Plug LFF (3.5-inch) Midline (MDL) Drives

HP 2TB 3G SATA 7.2K rpm LFF (3.5-inch) Midline 1yr Warranty Hard Drive	507632-B21
HP 1TB 3G SATA 7.2K rpm LFF (3.5-inch) Midline 1yr Warranty Hard Drive	454146-B21
HP 750GB 3G SATA 7.2K rpm LFF (3.5-inch) Midline 1yr Warranty Hard Drive	458930-B21
HP 500GB 3G SATA 7.2K rpm LFF (3.5-inch) Midline 1yr Warranty Hard Drive	458928-B21
HP 250GB 3G SATA 7.2K rpm LFF (3.5-inch) Midline 1yr Warranty Hard Drive	458926-B21

SATA Non-Hot Plug LFF (3.5-inch) Midline (MDL) Drives

HP 2TB 3G SATA 7.2K rpm LFF (3.5-inch) Non-hot Plug Midline 1yr Warranty Hard Drive	507774-B21
HP 1TB 3G SATA 7.2K rpm LFF (3.5-inch) Non-hot Plug Midline 1yr Warranty Hard Drive	507772-B21
HP 750GB 3G SATA 7.2K rpm LFF (3.5-inch) Non-hot Plug Midline 1yr Warranty Hard Drive	462595-B21
HP 500GB 3G SATA 7.2K rpm LFF (3.5-inch) Non-hot Plug Midline 1yr Warranty Hard Drive	458941-B21
HP 250GB 3G SATA 7.2K rpm LFF (3.5-inch) Non-hot Plug Midline 1yr Warranty Hard Drive	458939-B21

SATA Hot Plug SFF (2.5-inch) Entry (ETY) Drives

HP 250GB 3G SATA 5.4K rpm SFF (2.5-inch) Entry 1yr Warranty Hard Drive	460355-B21
HP 120GB 1.5G SATA 5.4K rpm SFF (2.5-inch) Entry 1yr Warranty Hard Drive	458924-B21

SATA Non-Hot Plug SFF (2.5-inch) Entry (ETY) Drives

HP 500GB 3G SATA 7.2K rpm SFF (2.5-inch) Non-hot plug Entry 1yr Warranty Hard Drive	628033-B21
HP 250GB 3G SATA 5.4K rpm SFF (2.5-inch) Non-hot Plug Entry 1yr Warranty Hard Drive	460357-B21
HP 120GB 1.5G SATA 5.4K rpm SFF (2.5-inch) Non-hot Plug Entry 1yr Warranty Hard Drive	459357-B21

SATA Hot Plug LFF (3.5-inch) Entry (ETY) Drives

HP 250GB 3G SATA 7.2K rpm LFF (3.5-inch) Entry 1yr Warranty Hard Drive	571230-B21
--	------------



QuickSpecs

HP Smart Array P400 Controller

Related Options

HP 160GB 3G SATA 7.2K rpm LFF (3.5-inch) Entry 1yr Warranty Hard Drive	458945-B21
SATA Non-Hot Plug LFF (3.5-inch) Entry (ETY) Drives	
HP 250GB 3G SATA 7.2K rpm LFF (3.5-inch) Non-hot Plug Entry 1yr Warranty Hard Drive	571232-B21
HP 160GB 3G SATA 7.2K rpm LFF (3.5-inch) Non-hot Plug Entry 1yr Warranty Hard Drive	458947-B21
Small Form Factor (SFF) SATA Hot Plug Drives	
HP 60GB 5.4K rpm Hot Plug SFF SATA 1yr Warranty Hard Drive	379306-B21
3.5" SATA Hot Plug Drives	
HP 80GB 7.2K rpm Hot Plug SATA 1yr Warranty Hard Drive	349237-B21
3.5" SATA Non-Hot Plug Drives	
HP 80GB 7.2K rpm Non Hot Plug SATA 1yr Warranty Hard Drive	383410-B21
SATA Hot Plug 2.5" Enterprise Mainstream Solid State Drives	
HP 400GB 3G SATA MLC SFF (2.5-inch) Enterprise Mainstream 3yr Warranty Solid State Drive	636597-B21
HP 200GB 3G SATA MLC SFF (2.5-inch) Enterprise Mainstream 3yr Warranty Solid State Drive	636595-B21
HP 120GB 3G SATA SFF (2.5-inch) Midline 1yr Warranty Solid State Drive	572073-B21
HP 100GB 3G SATA MLC SFF (2.5-inch) Enterprise Mainstream 3yr Warranty Solid State Drive	636593-B21
HP 60GB 3G SATA SFF (2.5-inch) Midline 1yr Warranty Solid State Drive	572071-B21
SATA Hot Plug 3.5" Midline (MDL) Solid State Drives	
HP 400GB 3G SATA MLC LFF (3.5-inch) Enterprise Mainstream 3yr Warranty Solid State Drive	636611-B21
HP 200GB 3G SATA MLC LFF (3.5-inch) Enterprise Mainstream 3yr Warranty Solid State Drive	636609-B21
HP 120GB 3G SATA LFF (3.5-inch) Midline 1yr Warranty Solid State Drive	570763-B21
HP 100GB 3G SATA MLC LFF (3.5-inch) Enterprise Mainstream 3yr Warranty Solid State Drive	636607-B21
HP 60GB 3G SATA LFF (3.5-inch) Midline 1yr Warranty Solid State Drive	570761-B21
SATA Non-hot Plug 2.5" Midline (MDL) Solid State Drives	
HP 400GB 3G SATA MLC SFF (2.5-inch) Non-hot plug Enterprise Mainstream 3yr Wty Solid State Drive	636605-B21
HP 200GB 3G SATA MLC SFF (2.5-inch) Non-hot plug Enterprise Mainstream 3yr Wty Solid State Drive	636601-B21
HP 120GB 3G SATA SFF (2.5-inch) Non-hot plug Midline 1yr Wty Solid State Drive	572077-B21
HP 100GB 3G SATA MLC SFF (2.5-inch) Non-hot plug Enterprise Mainstream 3yr Wty Solid State Drive	636599-B21
HP 60GB 3G SATA SFF (2.5-inch) Non-hot plug Midline 1yr Wty Solid State Drive	572075-B21
6G SAS Hot Plug Enterprise Performance Solid State Drives	
HP 200GB 6G SAS SLC SFF (2.5-inch) Enterprise Performance 3yr Warranty Solid State Drive	632492-B21
HP 400GB 6G SAS SLC SFF (2.5-inch) Enterprise Performance 3yr Warranty Solid State Drive	632494-B21



QuickSpecs

HP Smart Array P400 Controller

Related Options

6G SAS Hot Plug Enterprise Mainstream Solid State Drives

HP 200GB 6G SAS MLC SFF (2.5-inch) Enterprise Mainstream 3yr Warranty Solid State Drive	632502-B21
HP 400GB 6G SAS MLC SFF (2.5-inch) Enterprise Mainstream 3yr Warranty Solid State Drive	632504-B21
HP 800GB 6G SAS MLC SFF (2.5-inch) Enterprise Mainstream 3yr Warranty Solid State Drive	632506-B21

NOTE: Go to the [HP Hard Drive Compatibility table](http://www.hp.com/products/harddiskdrives) for complete drive compatibility information (<http://www.hp.com/products/harddiskdrives>). Using hard drives in unsupported configurations will result in voiding the warranty and could result in damage to the drive and/or loss of data.

NOTE: There is a known compatibility issue with some early 3.5" SATA HDD that will make them unable to be used with the SA-P400 controller. Customers should verify that they are not using hard drive part number 332649-002/003 (spare 353042-001), 332650-002/003 (spare 353043-001), or 356536-002/003 (spare 353044-001).

HP Tape Solutions

SAS Tape Drives

NOTE: Supported on HP Smart Array P400 Controller only.

HP DAT 160 SAS Internal Tape Drive	Q1587A
HP DAT 160 SAS External Tape Drive	Q1588A
HP Ultrium 448 SAS Internal Drive	DW085A
HP Ultrium 448 SAS External Drive	DW086A
HP Ultrium 920 SAS Internal Tape Drive	EH847A
HP Ultrium 920 SAS External Tape Drive	EH848A
HP LTO-4 Ultrium 1760 SAS Internal WW Tape Drive	EH919A
HP LTO-4 Ultrium 1760 SAS External Tape Drive	EH920A
HP LTO-4 Ultrium 1760 SAS (1) in 1U Rack-mount Kit	EH946A
HP LTO-4 Ultrium 1840 SAS Internal Tape Drive	EH860A
HP LTO-4 Ultrium 1840 SAS External WW Drive	EH861A

Rack-mount Tape Drive Enclosures

HP 1U SAS Rack-mount Kit	AE459A
--------------------------	--------

NOTE: The 1U SAS Rack-Mount Kit can support up to (2) half-height tape drives and is compatible with the DAT 160 SAS, LTO-2 Ultrium 448 SAS, LTO-3 Ultrium 920 SAS and LTO-4 Ultrium 1760 SAS tape drives.

HP 3U SAS Rack-mount Kit	AG576A
--------------------------	--------

NOTE: The 3U Rack-mount Kit can support up to (2) full-height or (4) half-height tape drives and compatible with multiple SAS tape drives including DAT 160 SAS, LTO-2 Ultrium 448 SAS, LTO-3 Ultrium 920 SAS, LTO-4 Ultrium 1760 SAS and LTO-4 Ultrium 1840 SAS tape drives.

SAS Cables for Tape Drives

HP StorageWorks 1m SAS Cable	AE490A
------------------------------	--------

NOTE: Use this cable to connect HP Ultrium 448, 920, 960, 1760 and 1840 SAS internal tape drives to SAS 4i (SFF8484) connectors. This replaces the existing cable connecting the HBA/controller to the disk backplane. This replacement cable has three channels for disks and 1 channel for the tape drive (SFF8482 port).



QuickSpecs

HP Smart Array P400 Controller

Related Options

HP StorageWorks 1m with Power SAS Cable

AE491A

NOTE: Use this cable to connect HP Ultrium 3280 and 3000 SAS internal tape drives to SAS 4i (SFF8484) connectors. This replaces the existing cable connecting the HBA/controller to the disk backplane. This replacement cable has three channels for disks and 1 channel for the tape drive (SFF8482 port).

HP 1U SAS TP I-E 3HDDs X 1Tape Drive X4M Server Cable Assembly Kit

AE464A

NOTE: This split cable connects internally to SAS Hard Drive Cage (3x) and externally to the tape device (1x) with other connector attaching to HP SAS controllers with SAS 4i (SFF8484) connectors. The 1x cable occupies additional PCI slot on the server.



QuickSpecs

HP Smart Array P400 Controller

Technical Specifications

Dimensions (not including bracket)	Low Profile PCIe Form Factor 6.61 in x 2.75 in x 0.7 in (16.8 cm x 7.0 cm x 1.8 cm)
Disk Drive and Enclosure Interface	3Gb/s SAS (Serial Attached SCSI) 3Gb/s SATA (Serial ATA)
SAS Connectors	2 internal (SFF8484) x4 wide port connectors
Cache Memory Speed	DDR2-533MHz with 40 or 72-bit wide bus provides up to 4.2 GB/s maximum bandwidth.
Server Interface	x8 2.5G PCIe provides 2GB/s maximum bandwidth
SAS Speed	x8 3G SAS provides 2.4GB/s maximum bandwidth
Cache Memory	40-bit 256MB ECC protected cache (72-bit 512MB module upgrades available); transportable with battery-backed upgrade
Logical Drives Supported	Up to 32 logical drives
Maximum Logical Drive Capacity	Greater than 2TB
Host Memory Addressing	64-bit, supporting greater than 4GB server memory space
RAID Support	RAID 6 with ADG (Advanced Data Guarding) requires Battery Backed Write Cache Upgrade RAID 5 (Distributed Data Guarding) RAID 1+0 (Striping & Mirroring) RAID 0 (Striping)
Upgradeable Firmware	Upgradeable Firmware with recovery ROM feature

Environment-friendly Products and Approach	End-of-life Management and Recycling	Hewlett-Packard offers end-of-life HP product return, trade-in, and recycling programs in many geographic areas. For trade-in information, please go to: http://www.hp.com/go/green . To recycle your product, please go to: http://www.hp.com/go/green or contact your nearest HP sales office. Products returned to HP will be recycled, recovered or disposed of in a responsible manner.
---	---	--

The EU WEEE directive (2002/95/EC) requires manufacturers to provide treatment information for each product type for use by treatment facilities. This information (product disassembly instructions) is posted on the Hewlett Packard web site at: <http://www.hp.com/go/green>. These instructions may be used by recyclers and other WEEE treatment facilities as well as HP OEM customers who integrate and re-sell HP equipment.

© Copyright 2012 Hewlett-Packard Development Company, L.P.

The information contained herein is subject to change without notice. Microsoft and Windows are registered trademarks or trademarks of Microsoft Corporation in the U.S. and/or other countries. The only warranties for HP products and services are set forth in the express warranty statements accompanying such products and services. Nothing herein should be construed as constituting an additional warranty. HP shall not be liable for technical or editorial errors or omissions contained herein.

For hard drives, 1GB = 1 billion bytes. Actual formatted capacity is less.

