

INSTALLATION INSTRUCTIONS

BULLETIN 17773C

TYPE 45A 50-OHM CONNECTORS FOR 7/8-IN. CABLE

Type 45A connectors are used with FHJ5-50A jacketed 7/8-in. foam dielectric HELIAX[®] 50-ohm coaxial cable and RX5 RADIAX^{T.M.} slotted coaxial cable.

READ THE INSTRUCTIONS THOROUGHLY BEFORE ASSEMBLY

TOOLS AND MATERIALS REQUIRED FOR ASSEMBLY

Hacksaw, fine blade	Knife	Tape, vinyl
File, flat	Wire brush	Wrenches (2) 1-5/16 in.
Longnose pliers	Scale, 6 in. (150 mm)	Solvent, comothene, vythene or other non-flammable cleaning fluid

STEP 1. Prepare cable as shown in Figure 1. Cable end must be square. If not, use hacksaw to make new cut. Use straight-edged piece of paper wrapped around cable to guide jacketing cut. Use knife to remove jacket. Clean outer conductor with solvent. Use file to remove burrs from outer conductor, and knife to gently deburr inner conductor. Use wire brush to remove copper particles from foam.

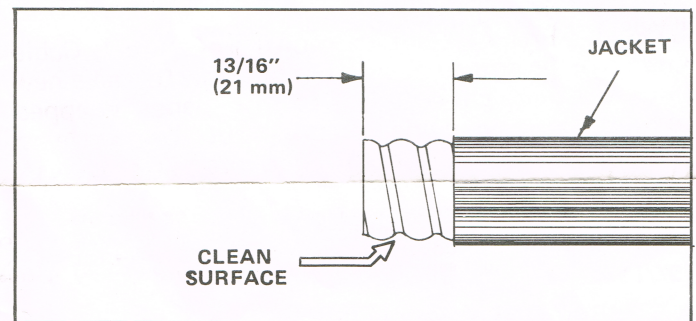

FIGURE 1

STEP 2. Screw self-tapping inner connector into inner conductor. Place pin provided through hole in connector and use it as handle to help in tapping. Refer to Figure 2. Tighten inner connector. Do not overtighten, as threads made in inner conductor may strip.

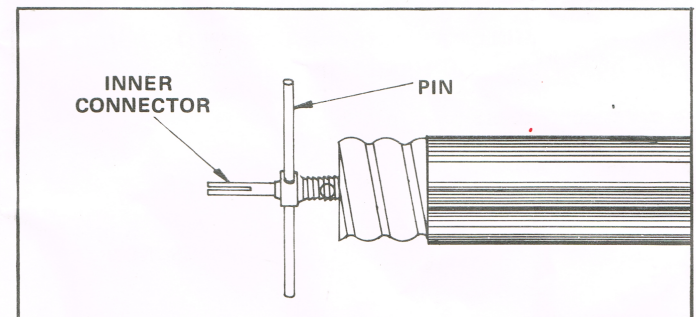

FIGURE 2

STEP 3. Cover foam at end of cable with silicone grease to seal pores. Also apply grease to clean surface of outer conductor. Screw clamping nut onto cable until outer conductor is exposed per dimension shown in Figure 3. Use longnose pliers to crimp outer conductor into opening in clamping nut as shown. This prevents clamping nut from rotating. Apply thin coating of silicone grease to threaded area of clamping nut. Wipe beveled end of clamping nut free of silicone grease.

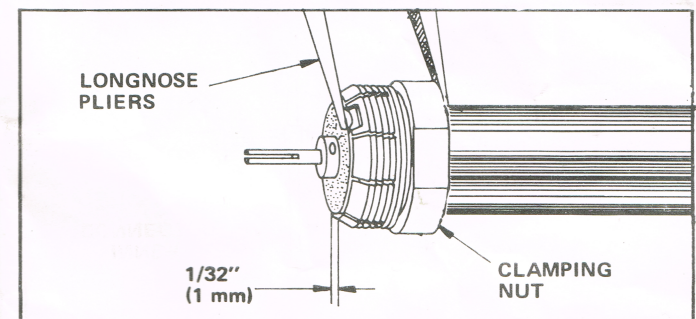

FIGURE 3

STEP 4. Screw outer body onto clamping nut. See Figure 4. Tighten connection with wrenches. Turn outer body only; do not turn clamping nut. Force silicone grease into opening between cable jacket and clamping nut to prevent moisture from entering. For further weatherproofing, tightly wind four to five layers of vinyl tape over opening and at least 1 in. (25 mm) to either side.

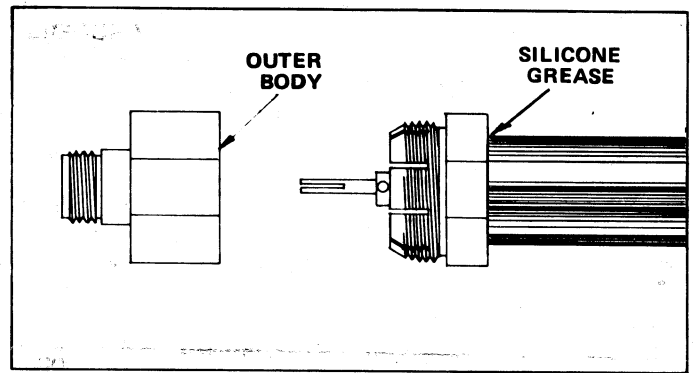

FIGURE 4

STEP 5. 45AGR ONLY. Gently place inner adaptor into base of GR connector on outer body, and engage it with inner connector. Refer to Figure 5. Use right turning motion to aid engagement. Align keyway in insulator with keyway in GR connector, then push adaptor toward outer body. Align key on end plug with keyways, then slide plug into position. Tighten plug in place with locking nut.

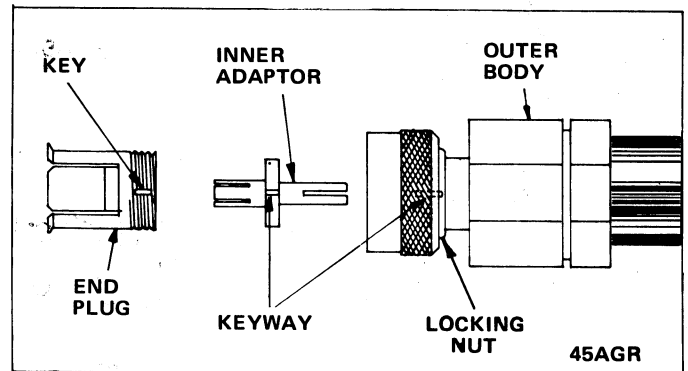

FIGURE 5

STEP 6. 45AT ONLY. Apply thin coating of silicone grease to large and small "O" rings. Slip large gasket and large "O" ring onto outside insulator, then slide assembly over inner connector extension and into outer body. Refer to Figure 6.

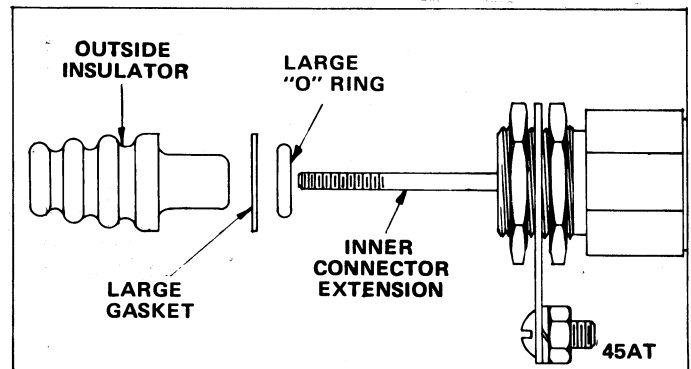

FIGURE 6

STEP 7. Force small "O" ring onto extension and into recess at end of insulator. See Figure 7. Add small gasket to step on bushing, then screw bushing to extension. Tighten bushing against outside insulator. Add flat washer, connecting strap, another flat washer, lockwasher and cap nut to complete assembly. Tighten cap nut.

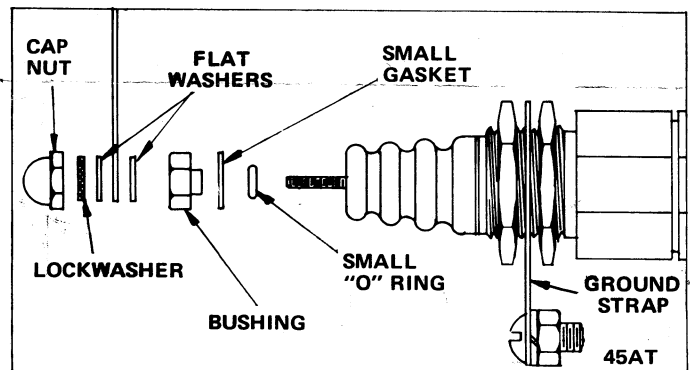

FIGURE 7