

**STRAIGHT PLUG CRIMP CENTER CONTACT
TYP CLAMP NUT CABLE D4**

R608.013.227
SERIES TQ

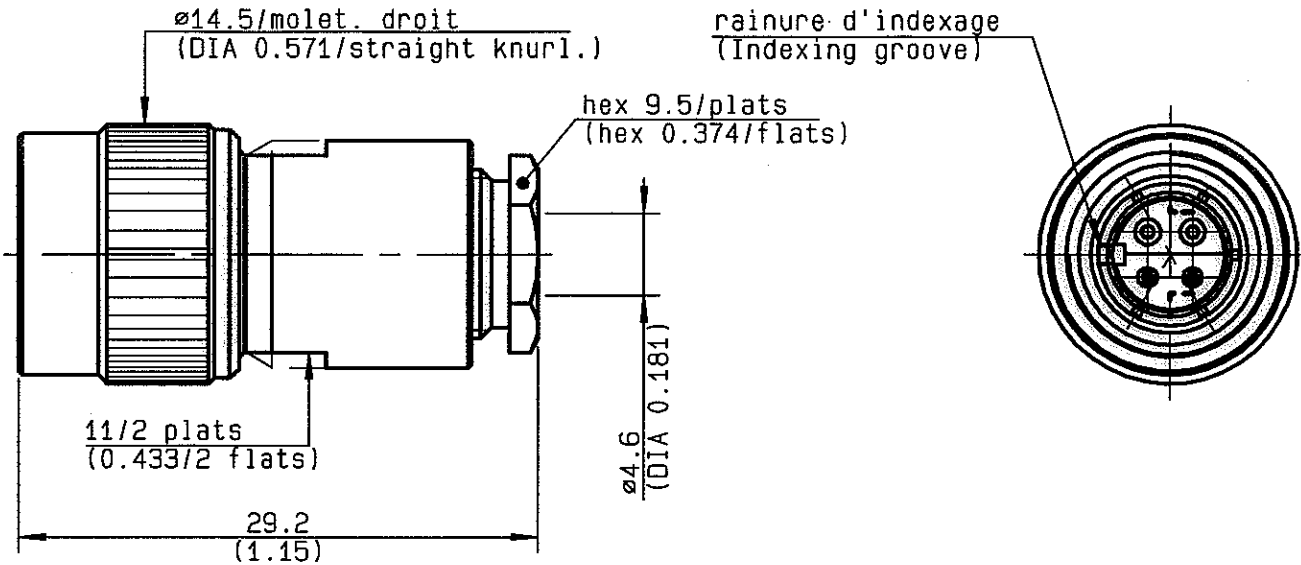

NOMINAL IMPEDANCE	120 Ω
FREQUENCY RANGE	0-0.03 GHz
TEMPERATURE RATING	-40/+100 °C
V.S.W.R	NA + x F(GHz)Maxi
RF INSERTION LOSS	NA √F(GHz) dB Maxi
VOLTAGE RATING	250 Veff Maxi
DIELECTRIC WITHSTANDING VOLTAGE	750 Veff Mini
INSULATION RESISTANCE	5000 MΩMini
HERMETIC SEAL	NA Atm.cm ³ /s
LEAKAGE (pressurized only)	NA
MECHANICAL DURABILITY	Cycles
WEIGHT	18.65 gr
SPECIFICATION	

CABLES :

OTHERS CHARACTERISTICS

According to Spec. :B4R062631AB issue X3

CABLE RETENTION	180 N Mini
CENTER CONTACT RETENTION	
Axial force - mating end	NA N Mini
Axial force - opposite end	10 N Mini
Torque	NA cm.N Mini
RECOMMENDED TORQUES	
Mating	cm.N
Panel nut	cm.N
Clamp nut	150 cm.N

CONNECTOR PARTS	MATERIALS	FINISH	(all values are given) in micrometers
BODY	BRASS	BBR 2	
OUTER CONTACT	BRASS	BBR 2	
CENTER CONTACT	BERYLLIUM COPPER, BRASS	GOLD 1.3 OVER NICKEL 2.	
INSULATOR	PA6 6 RF-1006(30%fibres verre)		
GASKET	SILICONE RUBBER	-	
OTHERS PIECES	BRASS	BBR 2	

ISSUE 0417000	CREATION DATE 15-JUL-97	FILE PART-NUMBER 96-0132-069
-------------------------	-----------------------------------	--



Connect to the future

The information given here is subject to change without notice.
Design changes may be in order to improve the product .

ANNEXU



RADIALL®

R608.013.227

ISSUE 0417 D00 SERIES TQ

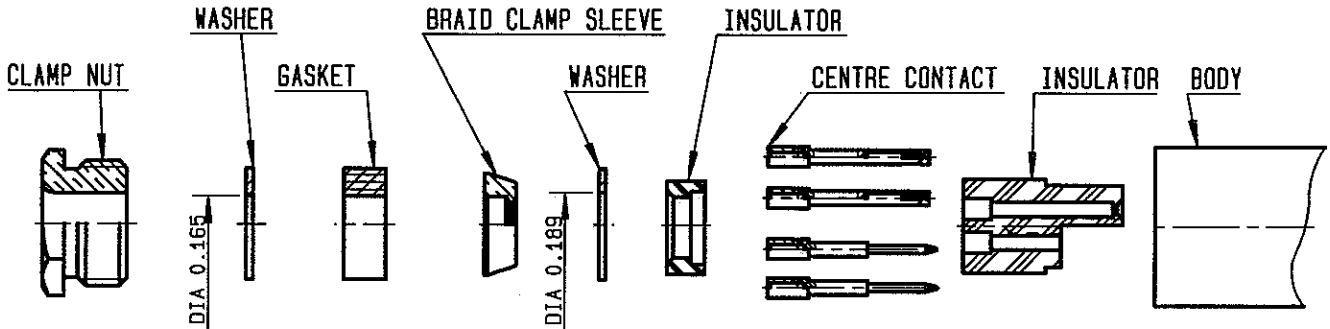

①

Strip the cable .

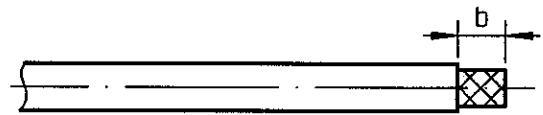

Stripping	a	b	c	d	e
inch	0.098	0.256	0	0	0.098
mm	2.5	6.5			2.5

②

Slide the clamp nut ,the washer and the gasket onto the cable .
 Slide clamp braid sleeve over braid .
 Fold back braid and trim off surplus braid .
 Trim back dielectric as shown to obtain a and e dimensions.

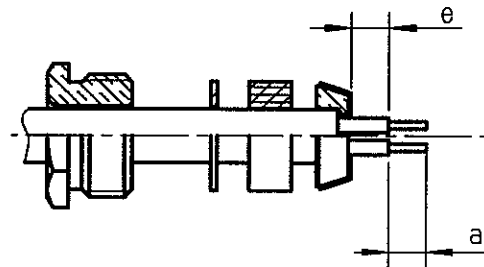

Crimp or solder the cable inner conductors into centre contacts. Take care of the polarity on centre contact (Contact according to cable colours)
 Crimping tool : R 282 281 000(position 8) or M22520/2-01 + positionner R 282 967 032
 Slide the washer and the spacer onto the dielectric.
 Assemble the second insulator

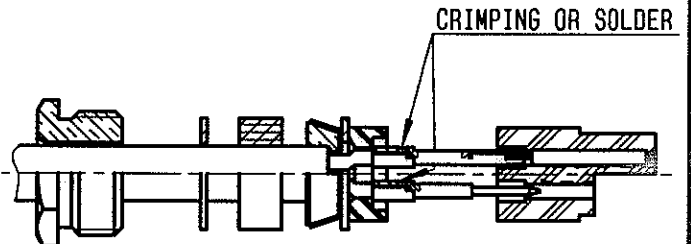

④

Introduce subassembly inot the connector body .
 Position the notch into groove and tight it (recommended coupling torque:13.27 in.lb)

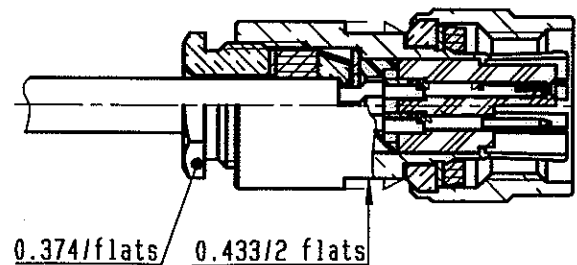

ANNEQUIN