

REV	ECN NO.	DATE	SIGN	DESCRIPTION
A		2004/09/13	LINK	INITIAL RELEASE
B	ECN-0411059	2004/11/17	Mason	Add Sealed bag
C	ECN-0504023	2005/04/04	MASON	Modify the screw nut & LTW typeface

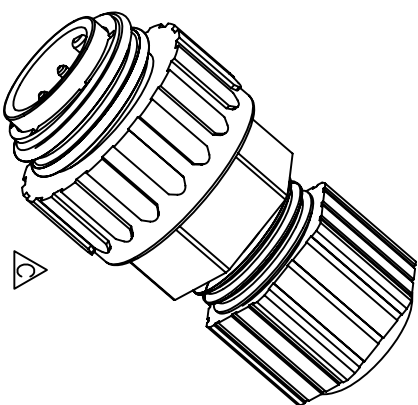

Note:  
 1. Seals for Cable OD:  $\phi 5.5\text{mm} \sim \phi 10.8\text{mm}$   
 (防水墊圈限用線徑:  $\phi 5.5\text{mm} \sim \phi 10.8\text{mm}$ )  
 2. One Set Unassembled in One LTW Sealed Bag  
 (每一組未組裝, 放置於一個 LTW 封口袋)

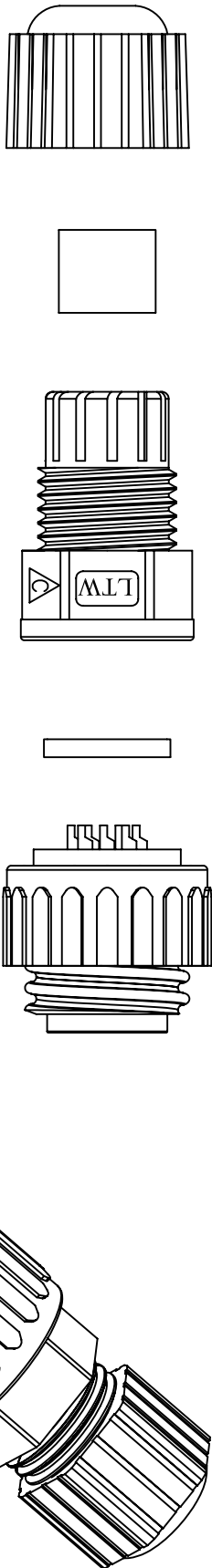
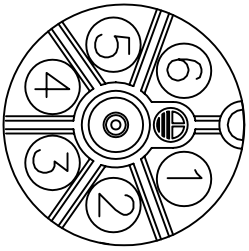
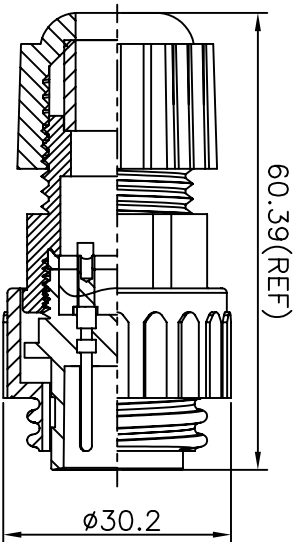

PINASSIGNMENTS  
 FRONT View  
 前視圖

NO.	NAME	COLOR	SPECIFICATION	QTY	NOTE
6	Sealed Bag			1	HP E00900085
5	Sealing Nut	Black	Nylon	1	ANC173XXX01
4	Seals	Black	EPDM	1	DGA0030EP70
3	Clamp Ring	Black	Nylon	1	ANC174XXX01
2	Gasket	Black	SILICONE	1	DGA0031S170
1	Connector	Black	6+PE Nylon+GF	1	ZMI0008XXXX

TITLE  
 6+PE POWER CONNECTOR(8A)

UNIT : mm  
 TOLERANCE  
 $\pm 0.5\text{mm}$

SCALE 1/1  
 REV. C  
 SIZE A4  
 SHEET 1 of 1  
 :inspection Item

LTW

亮泰企業股份有限公司

ITEM NO	DWG NO	CUSTOMER	DRAWN BY	CHECKED BY	APPROVED BY	DATE
LTWPWE-07BMMA-S180	LTWPWE-07BMMA-S180		Mason	Wang	Link	2005/04/11