

## SPARE PARTS LIST

---

#38	HAND OPERATED HYDRAULIC CRIMPING TOOL
#98	HAND OPERATED HYDRAULIC CRIMP TOOL
#41AH	HEAVY DUTY HYDRAULIC CRIMPING HEAD (C FRAME)
#98H	HEAVY DUTY HYDRAULIC CRIMPING HEAD (C FRAME)
#40BH	HYDRAULIC CRIMPING HEAD
#67H	HEAVY DUTY HYDRAULIC CRIMPING HEAD (U FRAME)
#38 ROBO	ROBO BATTERY OPERATED HYDRAULIC CRIMPING TOOL
#UC6ROBO	HEAVY DUTY BATTERY OPERATED HYDRAULIC CRIMPING TOOL
#98ROBO	HEAVY DUTY BATTERY OPERATED HYDRAULIC CRIMPING TOOL
#REC 50U	BATTERY OPERATED CABLE CUTTER
#CCSP55	HYDRAULIC CABLE CUTTER HEAD
#CCSP100	HYDRAULIC CABLE CUTTER HEAD
#CCS20A	HAND OPERATED HYDRAULIC CABLE CUTTER
#CCS40A	HAND OPERATED HYDRAULIC CABLE CUTTER
#108	RATCHET CABLE CUTTER

---

CATALOGUE INDEX

**INDEX**



# UTILUX | SPARE PARTS LIST

**Product - #38A**  
**Description - Hand Operated Hydraulic Crimping Tool**

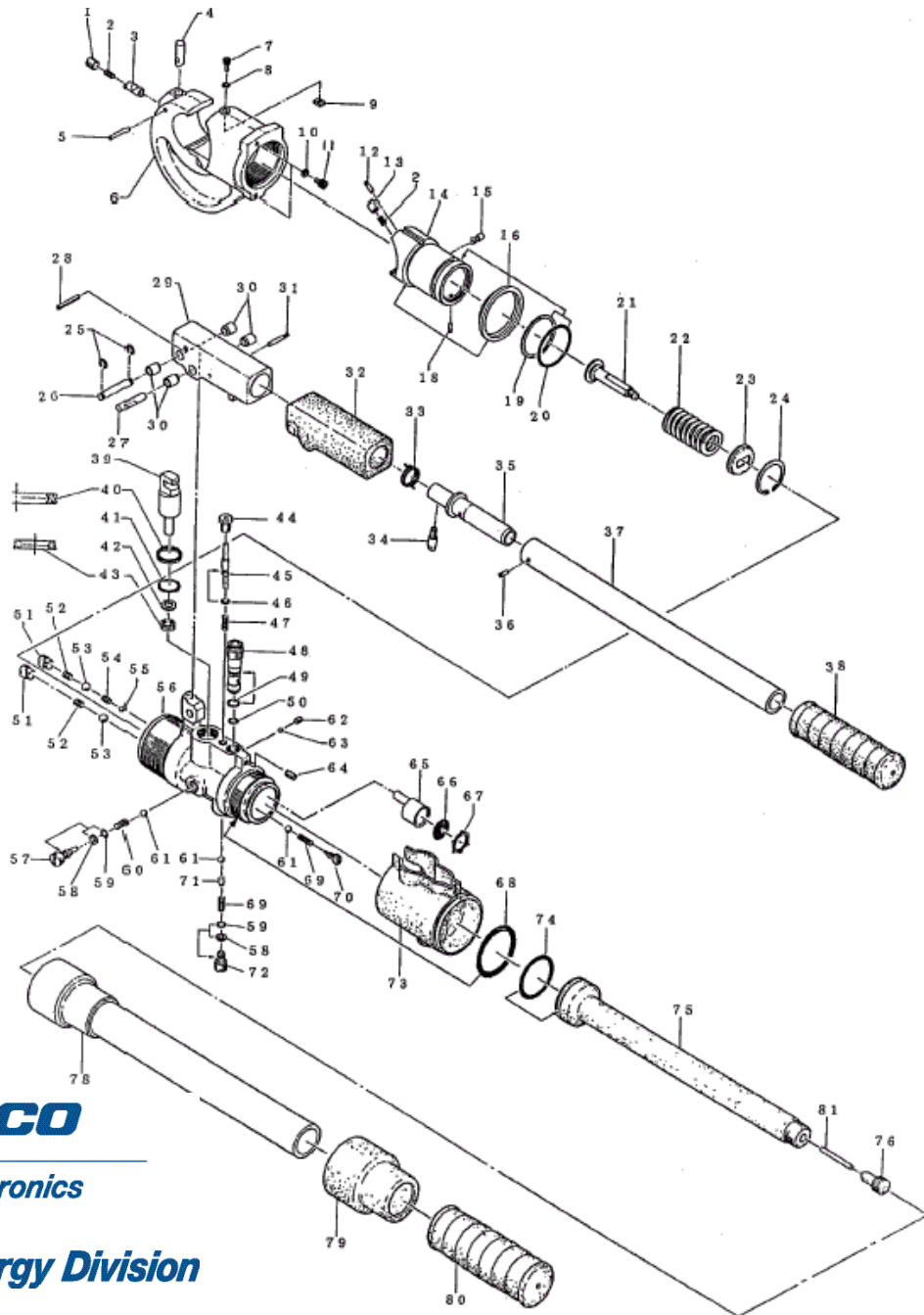

NO.	DESCRIPTION	CODE	QTY.
1	M10 X 10 Screw (F.P.)	16-41	1
2	Spring (177)	410-01	2
3	Retainer Pin (A)	410-02	1
4	Die Release Pin (A)	410-03	1
5	2.5 X 25 Drive Pin (BW)	410-04	1
6	Head	410-05	1
7	M4 X 10 Screw	410-06	1
8	M4 Lock Washer	410-07	1
9	Key	410-08	1
10	M5 Lock Washer	410-09	2
11	M5 X 6 Screw	410-10	2
12	2.5 X 14 Drive Pin (BW)	410-11	1
13	Retainer Pin (B)	410-12	1
14	Ram	410-13	1
15	Die Release Pin (B)	410-14	1
16	Dust Seal	430-03	1
18	2.5 x 8 Dowel Pin (B)	410-17	1
19	P-40 Back-Up Ring (B.C.)	22-16	1
20	P-40 O-Ring (C.P.)	410-70	1
21	Ram Spring Guide	410-18	1
22	Ram Spring (65)	410-19	1
23	Ram Spring Support	410-20	1
24	OV-36 Snap Ring	410-21	1
25	CE-7 Snap Ring	40-49	2
26	Pin (85)	410-22	1
27	Pin (84)	410-23	1
28	5 X 32 Dowel Pin (G)	85-57A	1
29	Pump Handle Head	410-24	1
30	Bushing	410-25	4
31	4 X 26 Dowel Pin (G)	410-26	1
32	Handle Head Insulation	410-27	1
33	Spring (146)	85-60	1
34	Push Pin	85-61	1
35	Pump Handle Stem	410-28	1
36	3 X 8 Dowel Pin (G)	410-29	1
37	Pump Handle	410-30	1
38	Pump Handle Grip (2)	410-31	1
39	Pump Piston	410-32	1
40	P-20 X-Ring	410-33	1
41	P-20 O-Ring (C.P.)	410-34A	1
42	P-8 Back-Up Ring (B.C.)	85-33	1
43	PS-8 Pent Seal	16-44	1
44	Release Valve Screw (7)	85-35	1
45	Release Valve Stem	410-35	1
46	P-3 O-Ring (C.P.)	UC-27	1
47	Spring (144)	85-37	1
48	Bypass Cartridge	410-36	1
49	S-9 O-Ring	410-71	1

NO.	DESCRIPTION	CODE	QTY.
50	P-8 O-Ring (C.P.)	410-43	1
51	Valve Screw (10)	410-44	2
52	Spring (67)	85-39	2
53	9/32" Ball	16-40	2
54	Spring (66)	85-40	1
55	3/16" Ball	16-49	1
56	Body	410-45	1
57	Suction Valve Plug	410-46	1
58	P-4 Back-Up Ring (B.C.)	410-47	2
59	P-4 O-Ring (C.P.)	410-48A	2
60	Spring (4)	16-48	1
61	7/32" Ball	16-26	3
62	M4 X 4 Screw (F.P.)	85-47	1
63	1/8" Ball	40-20	1
64	M5 X 8 Screw	410-49	1
65	Strainer	410-72A	1
66	Filter Screen	410-73	1
67	S1-20 Ring	410-74	1
68	G-40 O-Ring (C.P.)	P100A-05	1
69	Spring (43)	85-49	2
70	Valve Screw (22)	410-80	1
71	Spring Holder	410-51	1
72	Valve Plug (1)	410-52	1
73	Body Insulation	410-53	1
74	G-30 O-Ring	75-26	1
75	Oil Reservoir	410-54	1
76	Reservoir Cap	410-55	1
78	Body Handle Ass'y (Yellow)	410-58B	1
79	Handle Extension Insulation	410-59	1
80	Body Handle Grip	410-60	1
81	Magnet	ROB-25	1





# UTILUX | SPARE PARTS LIST

**Product - #38 ROBO**  
**Description - Battery Operated Hydraulic Crimping Tool**

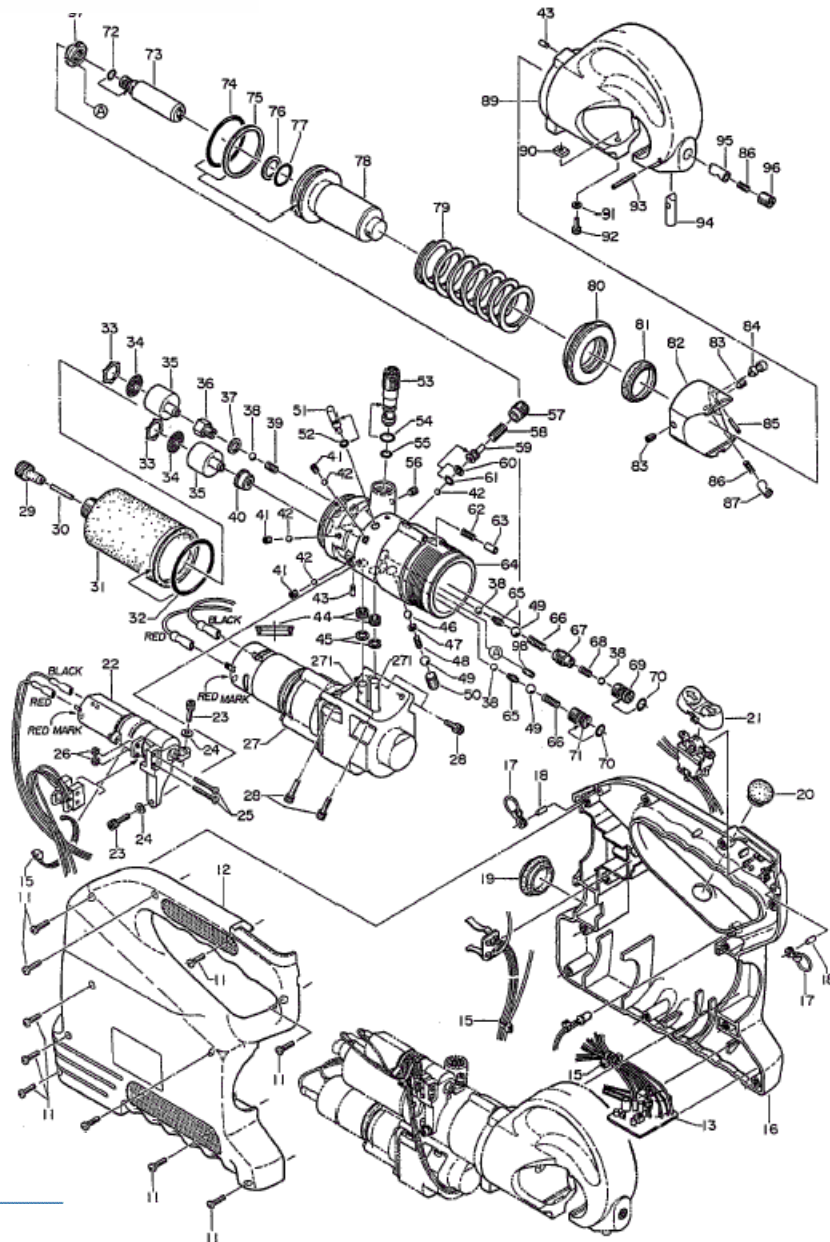

NO.	DESCRIPTION	CODE	QTY.		NO.	DESCRIPTION	CODE	QTY.	
11	M4 X 15 Screw	R150-01	10		60	P-5 Back-Up Ring (B.C.)	E3-126	1	
12	Housing (R)	351-01	1		61	P-5 O-Ring	5N-35	1	
13	Control Unit	351-02	1		62	Spring (371)	51-17	1	
15	Binder	HR-30	3		63	Stopper Pin	351-16	1	
16	Housing (L)	351-03	1		64	Body	351-17	1	
17	Hanging Ring Ass'y	ROB-101A	2		65	Spring (66)	85-40	2	
18	4 X 12 Parallel Pin	351-04	2		66	Spring (67)	85-39	2	
19	Oil Feed Cap	351-05	1		67	Valve Screw (2)	351-18	1	
20	Cartridge Cap	ROB-103	1		68	Spring (340)	51-27	1	
21	Switch Knob	351-06	1		69	Valve Screw (3)	351-19	1	
22	Release Unit	351-07	1		70	P-7 O-Ring	16-60	2	
23	M4 X 10 Screw	351-08	2		71	Valve Screw (1)	R510A-09	1	
24	M4 Flat Washer	16-81	2		72	S-5 O-Ring	351-20	1	
25	M2.3 X 25 Screw	ROB-86	2		73	Inner Pipe	341-01A	1	
26	M2.3 Hex Nut	P500-22	2		74	P-41 O-Ring	L100-23	1	
27	Power Unit	351-09	1		75	P-41 Back-Up Ring (B.C.)	16B-04	1	
28	M4 X 14 Screw (Ni)	ROB-128B	4		76	P-16 Back-Up Ring (B.C.)	22-24	1	
29	Reservoir Cap	410-55	1		77	P-16 O-Ring	22-25	1	
30	Magnet	ROB-25	1		78	Ram	341-02B	1	
31	Oil Reservoir (37)	351-10	1		79	Ram Spring (596)	341-03	1	
32	P-40 O-Ring	700S-27	1		80	Guide Ring	341-04	1	
33	SI-20 Ring	410-74	2		81	SER-30 Scraper	R510-03	1	
34	Filter Screen	410-73	2		82	Ram Head	341-05A	1	
35	Strainer	9H-43A	2		83	M5 X 8 Screw (C.P.)	P55A-02	2	
36	Strainer Bushing (1)	351-11	1		84	Die Release Pin	430-21	1	
37	Copper Gasket (20)	100W-17	1		85	2.5 X 14 Drive Pin (BW)	410-11	1	
38	3/16" Ball	16-49	4		86	Spring (177)	410-01	2	
39	Spring (340)	51-27	1		87	Retainer Pin (B)	410-12	1	
40	Strainer Bushing (2)	ROB-82	1		89	Head	341-07	1	
41	M5 X 5 Screw (F.P.)	510A-05	3		90	Key	410-08	1	
42	5/32" Ball	22-21	4		91	M4 Lock Washer	410-07	1	
43	3 X 8 Dowel Pin (D)	610F-11	2		92	M4 X 10 Screw	410-06	1	
44	PS-8 Pent Seal	16-44	2		93	2.5 X 25 Drive Pin (BW)	410-04	1	
45	P-8 Back-Up Ring (B.C.)	85-33	2		94	Die Release Pin (A)	410-03	1	
46	7/32" Ball	16-26	1		95	Retainer Pin (A)	410-02	1	
47	M3 Flat Washer	16-38	1		96	M10 X 10 Screw (F.P.)	16-41	1	
48	Spring (76)	16-39	1		97	Stopper Nut	351-30	1	
49	9/32" Ball	16-40	3		98	M4 X 10 Screw	46M-04	1	
50	M10 X 12 Screw (F.P.)	40-47	1		271	Pump Piston (2)	P500-10	2	
51	Release Pin	351-12	1						
52	P-3 O-Ring	16-36	1						
53	Valve Cartridge	R510-18A	1						
54	S-9 O-Ring	410-71	1						
55	P-8 O-Ring (B)	700S-15	1						
56	M5 X 5 Screw	300-73	1						
57	Valve Screw (4)	351-13	1						
58	Spring (595)	351-14	1						
59	Reduction Valve	351-15	1						



# UTILUX | SPARE PARTS LIST

Product - #108

Description - Ratchet Cable Cutter

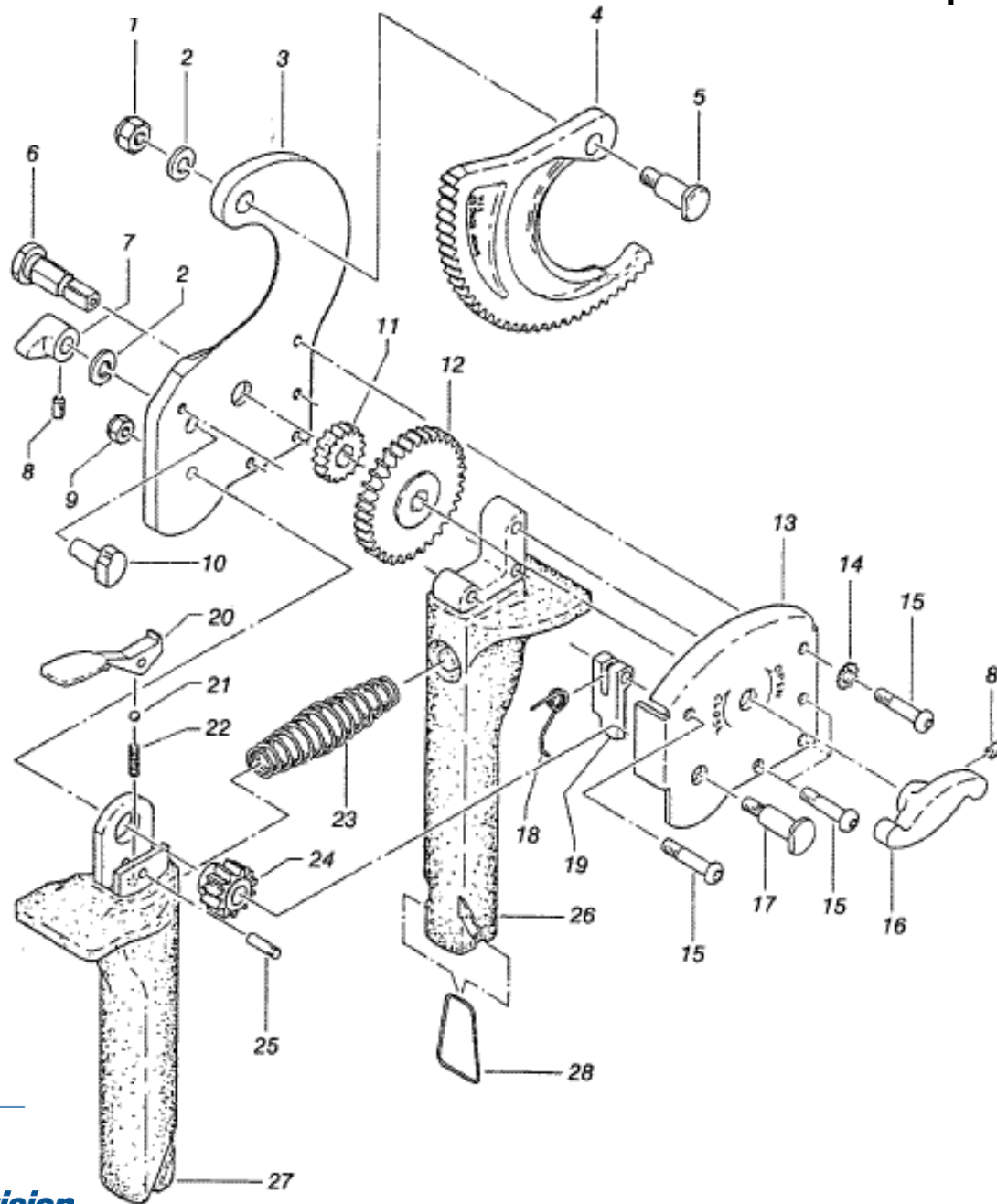

NO.	DESCRIPTION	CODE	QTY
1	Hex. nut	RCC-01	1
2	Lock washer	16-02	2
3	Stationary blade	RCC-03	1
4	Moving Blade	RCC-03	1
5	Pivot Pin	RCC-04	1
6	Gear Shaft	RCC-05	1
7	Stop knob	RCC-06	1
8	Screw	RCC-07	2
9	Hex. nut	RCC-08	1
10	Pawl	RCC-09	1
11	Small gear	RCC-10	1
12	Large gear	RCC-11	1
13	Housing	RCC-12	1
14	Star washer	RCC-13	1
15	Bolt	RCC-14	3
16	Hand crank	RCC-15	1
17	Gear pin	RCC-16	1
18	Spring	RCC-17	1
19	Pawl stopper	RCC-18	1
20	Ratchet lever	RCC-19	1
21	Ball	RCC-20	1
22	Spring	RCC-21	1
23	Handle spring	RCC-22	1
24	Medium gear	RCC-23	1
25	Dowel pin	RCC-24	1
26	Stationary handle	RCC-25	1
27	Moving handle	RCC-26	1
28	Handle retainer	RCC-27	1
29	M10 x 10 Hex screw	RCC-28	1

**tyco**

Electronics

Energy Division

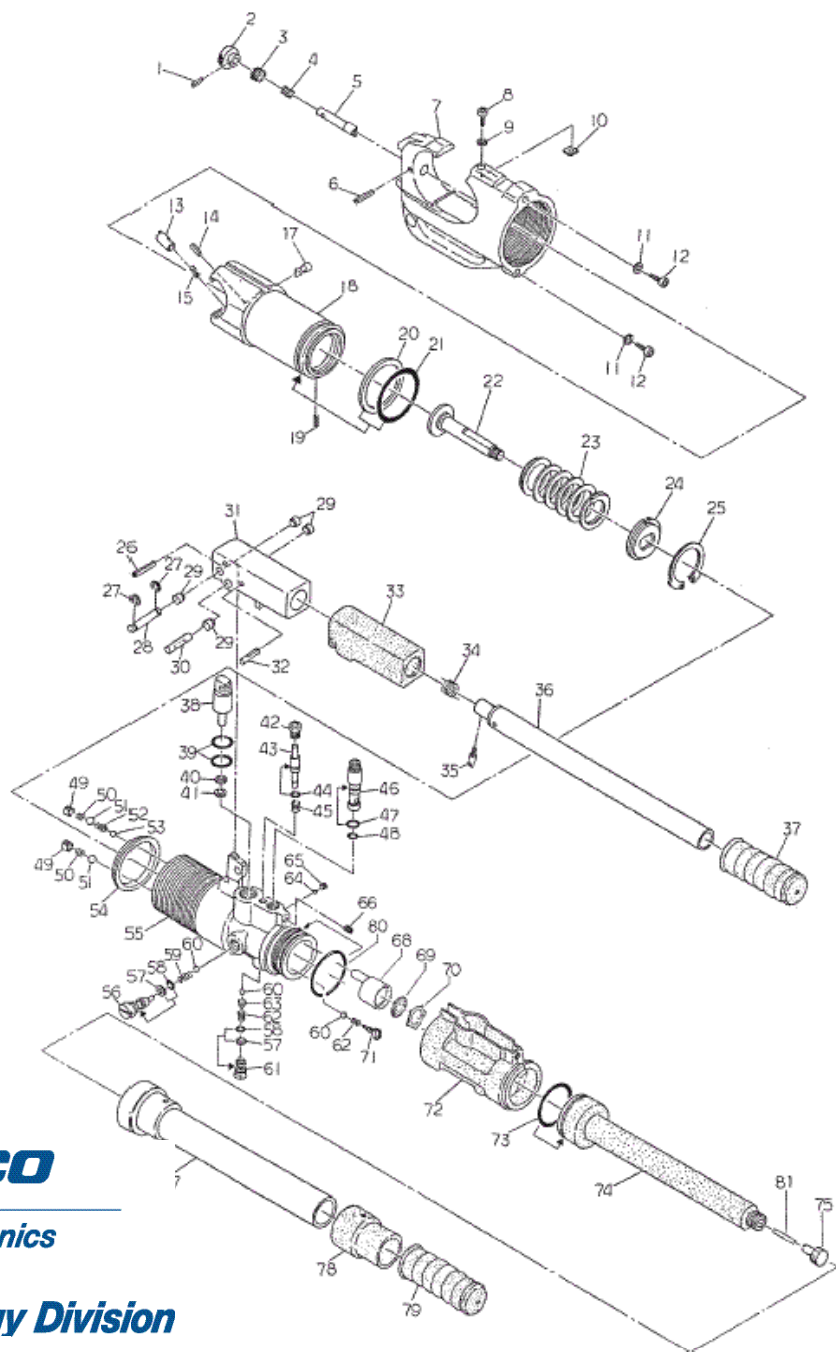

NO.	DESCRIPTION	CODE	QTY.	NO.	DESCRIPTION	CODE	QTY.
1	2 X 12 Drive Pin (AW)	40-21	1	50	Spring (67)	85-39	2
2	Knob	510-01	1	51	9/32" Ball	16-40	2
3	Screw (16)	510-02	1	52	Spring (66)	85-40	1
4	Spring (257)	510-03	1	53	3/16" Ball	16-49	1
5	Retainer Pin (A)	510-04	1	54	SER-48 Scraper	510-23	1
6	2.5 X 25 Drive Pin (BW)	410-04	1	55	Body	510-26	1
7	Head	510A-09	1	56	Suction Valve Plug	410-46	1
8	Guide Screw	510A-15	1	57	P-4 Back-Up Ring (B.C.)	410-47	2
9	M5 Lock Washer (Small)	510-12	1	58	P-4 O-Ring (C.P.)	410-48A	2
10	Key	510A-06	1	59	Spring (4)	16-48	1
11	M5 Lock Washer	410-09	2	60	7/32" Ball	16-26	3
12	M5 X 6 Screw	410-10	2	61	Valve Plug (1)	410-52	1
13	Retainer Pin (B)	410-12	1	62	Spring (43)	85-49	2
14	2.5 X 14 Drive Pin (BW)	410-11	1	63	Spring Holder	410-51	1
15	Spring (177)	410-01	1	64	5/32" Ball	22-21	1
17	Die Release Pin	430-21	1	65	M5 X 5 Screw (F.P.)	510A-05	1
18	Ram	510A-17	1	66	M5 X 8 Screw	410-49	1
19	2.5 x 8 Dowel Pin (B)	410-17	1	68	Strainer	410-72A	1
20	P-42 Back-Up Ring (B.C.)	510-18	1	69	Filter Screen	410-73	1
21	P-42 O-Ring	9H-17	1	70	SI-20 Ring	410-74	1
22	Spring Holder	510A-20	1	71	Valve Screw (22)	410-80	1
23	Ram Spring (311)	510A-21	1	72	Body Insulation	510A-27	1
24	Ram Spring Support	410-20	1	73	G-30 O-Ring	75-26	1
25	OV-36 Snap Ring	410-21	1	74	Oil Reservoir	510-28	1
26	5 X 32 Dowel Pin (G)	85-57A	1	75	Reservoir Cap	410-55	1
27	CE-7 Snap Ring	40-49	2	77	Body Handle Ass'y (White)	510-30	1
28	Pin (85)	410-22	1	78	Handle Extension Insulation	510-33	1
29	Bushing	410-25	4	79	Body Handle Grip	510-31	1
30	Pin (84)	410-23	1	80	G-40 O-Ring	P100A-05	1
31	Pump Handle Head	410-24	1	81	Magnet	ROB-25	1
32	4 X 26 Dowel Pin (G)	410-26	1				
33	Handle Head Insulation	410-27	1				
34	Spring (146)	85-60	1				
35	Push Pin	85-61	1				
36	Pump Handle Ass'y (White)	410-30W	1				
37	Pump Handle Grip (2)	410-31	1				
38	Pump Piston	510-22	1				
39	P-22 O-Ring (C.P.)	510-24A	2				
40	P-9 Back-Up Ring (B.C.)	32A-01	1				
41	PS-9 Pent Seal	32-18	1				
42	Release Valve Screw (7)	85-35	1				
43	Release Valve Stem	410-35	1				
44	P-3 O-Ring (C.P.)	UC-27	1				
45	Spring (144)	85-37	1				
46	Bypass Cartridge	410-36	1				
47	S-9 O-Ring	410-71	1				
48	P-8 O-Ring (C.P.)	410-43	1				
49	Valve Screw (10)	410-44	2				

**UTILUX** | **SPARE PARTS LIST** | Product - #41AH  
 Description - Heavy Duty Hydraulic Crimping Head (C Frame)

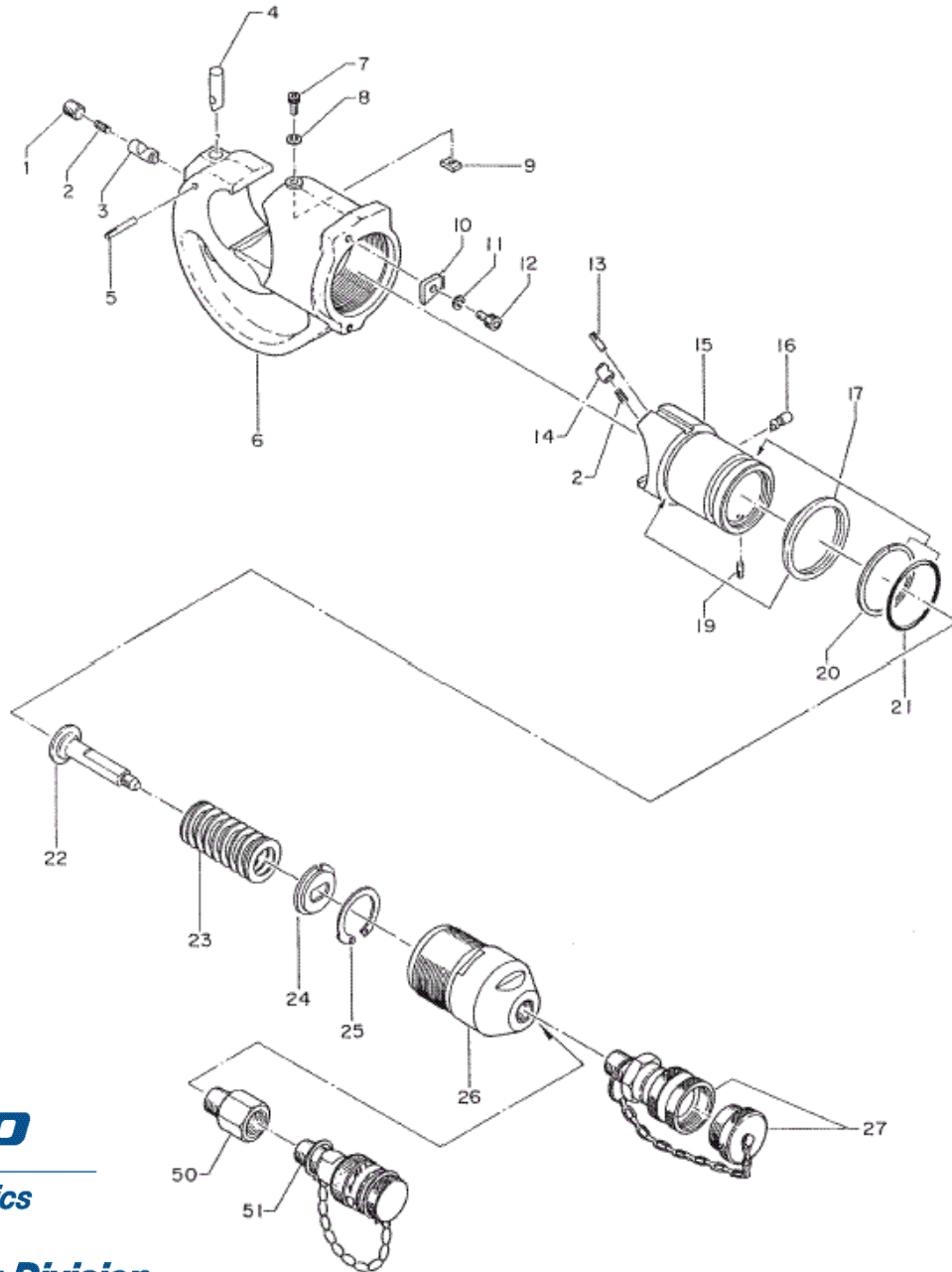

NO.	DESCRIPTION	CODE	QTY.
1	M10 X 10 Screw (F.P.)	16-41	1
2	Spring (177)	410-01	2
3	Retainer Pin (A)	410-02	1
4	Die Release Pin (A)	410-03	1
5	2.5 X 25 Drive Pin (BW)	410-04	1
6	Head	410-05	1
7	M4 X 10 Screw	410-06	1
8	M4 Lock Washer	410-07	1
9	Key	410-08	1
10	Stopper	410H-01	1
11	M5 Lock Washer	410-09	1
12	M5 X 10 Screw	410H-02	1
13	2.5 X 14 Drive Pin (BW)	410-11	1
14	Retainer Pin (B)	410-12	1
15	Ram	410-13	1
16	Die Release Pin (B)	410-14	1
17	Dust Seal	430-03	1
19	2.5 x 8 Dowel Pin (B)	410-17	1
20	P-40 Back-Up Ring (B.C.)	22-16	1
21	P-40 O-Ring (C.P.)	410-70	1
22	Ram Spring Guide	410-18	1
23	Ram Spring (65)	410-19	1
24	Ram Spring Support	410-20	1
25	OV-36 Snap Ring	410-21	1
26	Cylinder	410H-03	1
27	Female Coupler P.H. Type	P85-81	1
50	Adapter 3/8" NPT-M. 3/8" PT-F.	410H-80	1
51	Female Coupler IZUMI	100-24	1

**UTILUX** | **SPARE PARTS LIST** | Product - #98H  
 Description - Heavy Duty Hydraulic Crimping Head (C Frame)

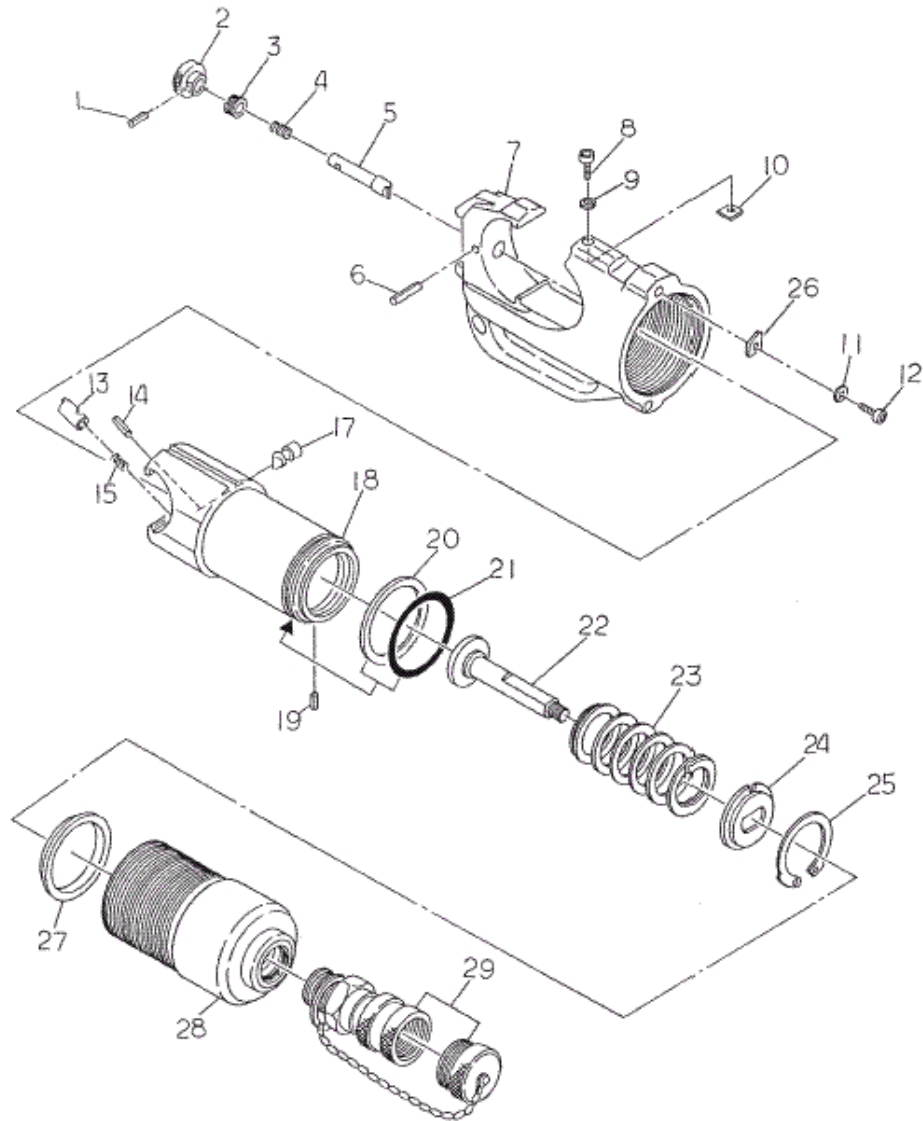

NO.	DESCRIPTION	CODE	QTY.
1	2 X 12 Drive Pin (AW)	40-21	1
2	Knob	510-01	1
3	Screw (16)	510-02	1
4	Spring (257)	510-03	1
5	Retainer Pin (A)	510-04	1
6	2.5 X 25 Drive Pin (BW)	410-04	1
7	Head	510A-09	1
8	Guide Screw	510A-15	1
9	M5 Lock Washer (Small)	510-12	1
10	Key	510A-06	1
11	M5 Lock Washer	410-09	1
12	M5 X 10 Screw	410H-02	1
13	Retainer Pin (B)	410-12	1
14	2.5 X 14 Drive Pin (BW)	410-11	1
15	Spring (177)	410-01	1
17	Die Release Pin	430-21	1
18	Ram	510A-17	1
19	2.5 x 8 Dowel Pin (B)	410-17	1
20	P-42 Back-Up Ring (B.C.)	510-18	1
21	P-42 O-Ring (C.P.)	HF-08	1
22	Spring Holder	510A-20	1
23	Ram Spring (311)	510A-21	1
24	Ram Spring Support	410-20	1
25	OV-36 Snap Ring	410-21	1
26	Stopper	410H-01	1
27	SER-48 Scraper	510-23	1
28	Cylinder	510HA-01	1
29	Female Coupler P.H. Type	P85-81	1



**UTILUX** | **SPARE PARTS LIST** | Product - #67H  
 Description - Heavy Duty Hydraulic Crimping Head (U Frame)

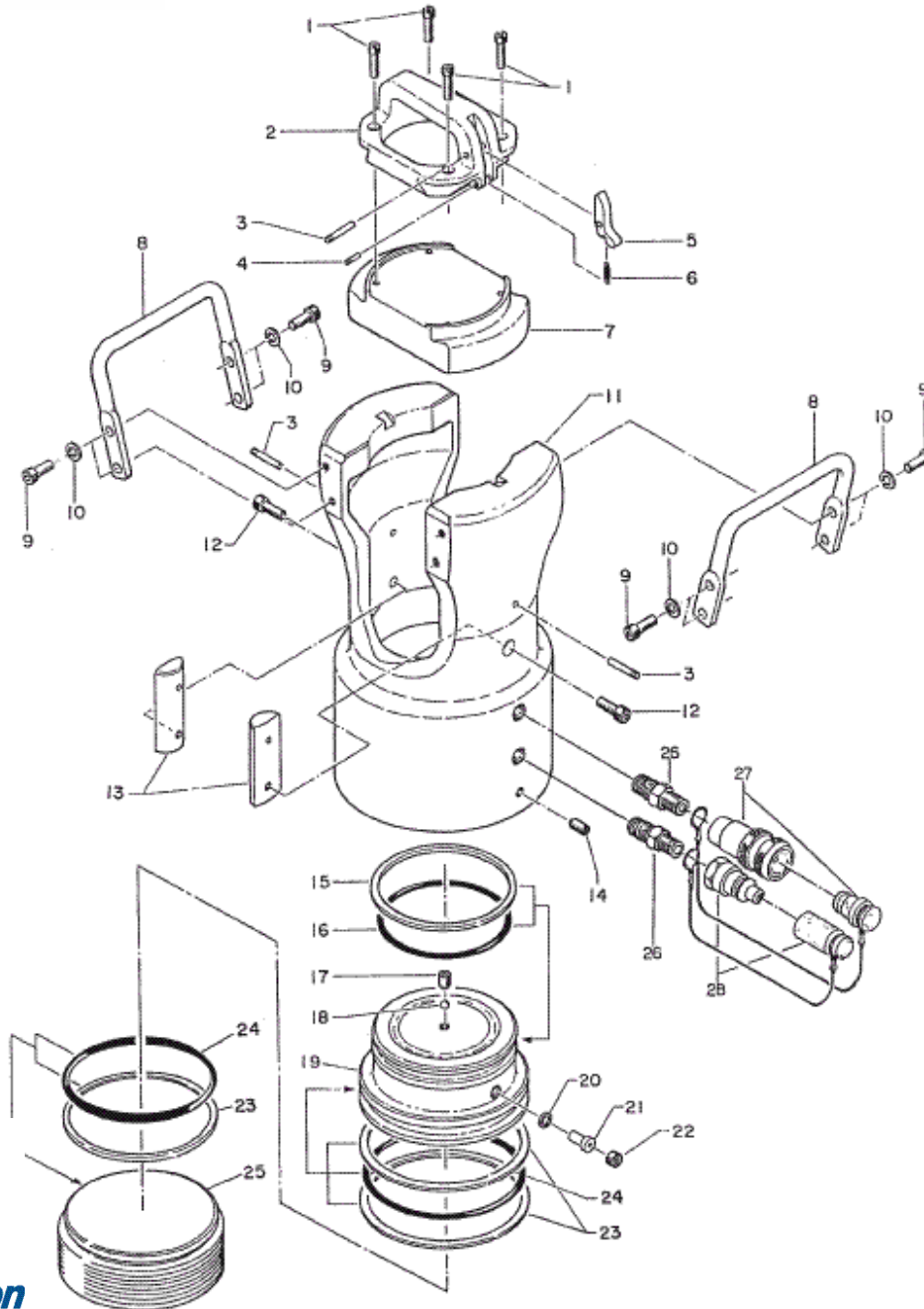

NO.	DESCRIPTION	CODE	QTY.
1	M6 X 25 Screw	100W-01	4
2	Cap Handle	100W-02	1
3	5 X 30 Dowel Pin (G)	38A-03	3
4	2.5 X 14 Dowel Pin (G)	100W-03	1
5	Trigger	100W-04	1
6	Spring (180)	38A-06	1
7	Head Cap	100W-06	1
8	Grip	100W-07	2
9	M8 X 18 Screw	100W-08	8
10	M8 Lock Washer	40-25	8
11	Cylinder	100W-09	1
12	M8 X 20 Screw	100W-10	2
13	Stopper	100W-11	2
14	M8 X 15 Screw (C.P.)	100W-12	2
15	P-105 Back-Up Ring (E.L.)	100W-13A	1
16	P-105 O-Ring	100W-14	1
17	M8 X 10 Screw (F.P.)	410-37	1
18	1/4" Ball	26-22	1
19	Ram	100W-16	1
20	Copper Gasket (20)	100W-17	1
21	Safety Valve Ass'y	100W-18	1
22	Retaining Screw	100W-26	1
23	P-125 Back-Up Ring (E.L.)	100W-20A	3
24	P-125 O-Ring	100W-21	2
25	Cylinder Cap	100W-22	1
26	Nipple 3/8" PT-M. 3/8" PT-M.	60-18	2
27	Female Coupler BI	E3-28	1
28	Male Coupler BI	E3-30	1



# UTILUX | SPARE PARTS LIST

Product - #UC6ROBO

Description - Heavy Duty Battery Operated Hydraulic Crimping Tool

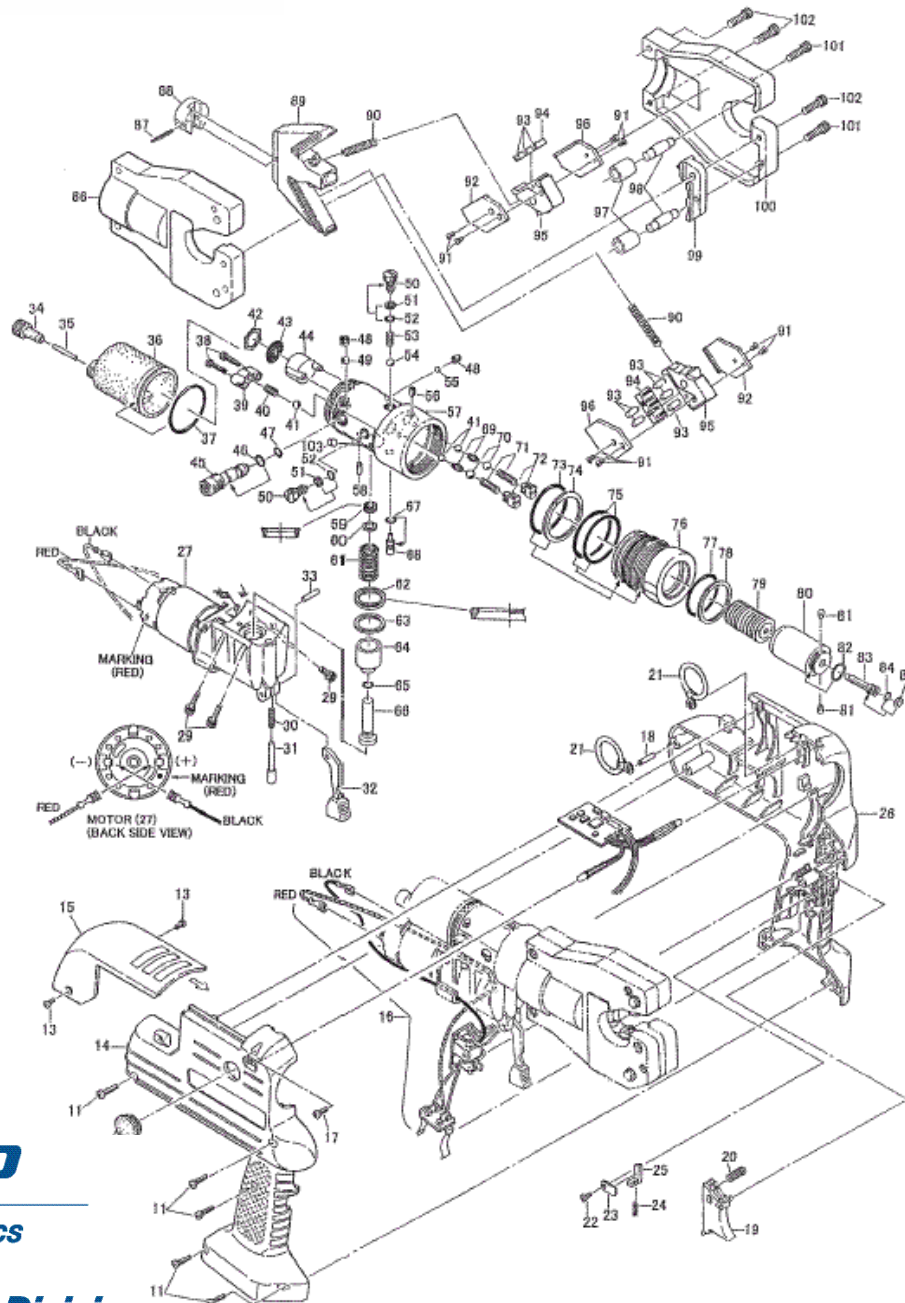

NO.	DESCRIPTION	CODE	QTY.
11	M4 X 15 Screw	R150-01	5
12	Cartridge Cap	ROB-103	1
13	M3 X 6 Screw	R150-02	2
14	Housing (R)	R150-03	1
15	Reservoir Cover	R150-04	1
16	LED Unit (4)	R150-05	1
17	M3 X 10 Screw	ROB-160	1
18	4 X 16 Parallel Pin	R150-07	1
19	Trigger	R150-08	1
20	Spring (599)	R150-09	1
21	Hanging Ring Ass'y	R150-10	2
22	M3 X 5 Screw (T.P.)	ROB-94	1
23	Retaining Plate	458-01	1
24	Spring (639)	458-02	1
25	Stopper	458-03	1
26	Housing (L)	R150-11	1
27	Power Unit	R150-12	1
29	M4 X 14 Screw (Ni)	ROB-126B	4
30	Spring (598)	R150-13	1
31	Push Pin	R150-14	1
32	Release Lever	R150-06B	1
33	4 X 16 Dowel Pin (G)	24-01	1
34	Reservoir Cap	410-55	1
35	Magnet	ROB-25	1
36	Oil Reservoir (36)	R4412-01	1
37	G-30 O-Ring	75-26	1
38	M3 X 16 Screw	R150-16	2
39	Valve Block	R150-17	1
40	Spring (302)	610-06	1
41	3/16" Ball	16-49	3
42	SI-20 Ring	410-74	1
43	Filter Screen	410-73	1
44	Strainer	R150-18	1
45	Valve Cartridge	R150-19E	1
46	S-8 O-Ring	R510A-08	1
47	P-7 O-Ring	16-60	1
48	M4 X 4 Screw (F.P.)	85-47	2
49	Retainer	R150-21	1
50	Plug	51-21	2
51	P-4 Back-Up Ring (B.C.)	410-47	2
52	P-4 O-Ring	410-48	2
53	Spring (341)	51-20	1
54	7/32" Ball	16-26	1
55	1/8" Ball	40-20	1
56	M4 X 5 Screw (C.P.)	55A-24	1
57	Body	6E-01	1
58	3 X 8 Dowel Pin (D)	610F-11	1
59	PS-8 Pent Seal	16-44	1

NO.	DESCRIPTION	CODE	QTY.
60	P-8 Back-Up Ring (B.C.)	85-33	1
61	Spring (590)	R150-23	1
62	PS-20 Pent Seal	R150-24	1
63	P-20 Back-Up Ring (B.C.)	35-18	1
64	Pump Piston (1)	R150-25	1
65	P-5 O-Ring	5N-35	1
66	Pump Piston (2)	R150-26	1
67	P-3 O-Ring	16-36	1
68	Release Valve Stem	ROB-135	1
69	Spring (66)	85-40	2
70	9/32" Ball	16-40	2
71	Spring (67)	85-39	2
72	Valve Screw (10)	410-44	2
73	P-38 O-Ring	26-37	1
74	P-38 Back-Up Ring (B.C.)	150A-11	1
75	S-40 O-Ring	C60-25	2
76	Cylinder	6E-02	1
77	P-34 O-Ring	85-23	1
78	P-34 Back-Up Ring (B.C.)	85-22	1
79	Ram Spring (370)	UC-17	1
80	Ram	UC-16	1
81	M4 X 6 Screw (F.P.)	16-42	2
82	Spring (406)	UC-44	1
83	Retaining Screw	UC-12	1
84	P-6 O-Ring	RB-70	1
85	P-6 Back-Up Ring (B.C.)	UC-28	1
86	Tool Cover (B)	6A-10	1
87	4 X 30 Drive Pin (AW)	UC-14	1
88	Cam Yoke Holder	UC-13A	1
89	Cam Yoke	6A-09	1
90	Side Jaw Spring (369)	UC-06	2
91	M3 X 8 Screw	6A-11	8
92	Slide Plate (1)	6A-08	2
93	Roller	UC-07	10
94	Roller Retainer	UC-08	2
95	Slide Jaw	6A-07	2
96	Slide Plate (2)	6A-06	2
97	Bushing	6A-04	2
98	Pin (2)	6A-03	2
99	Fixed Jaw	UC-03	1
100	Tool Cover (A)	6A-02	1
101	M5 X 30 Screw	EG-64	2
102	M6 X 30 Screw	E3-49	3
104	Expander MB700-050	FF-07	1



# UTILUX | SPARE PARTS LIST

**Product - #98ROBO**  
**Description - Heavy Duty Battery Operated Hydraulic Crimping Tool**

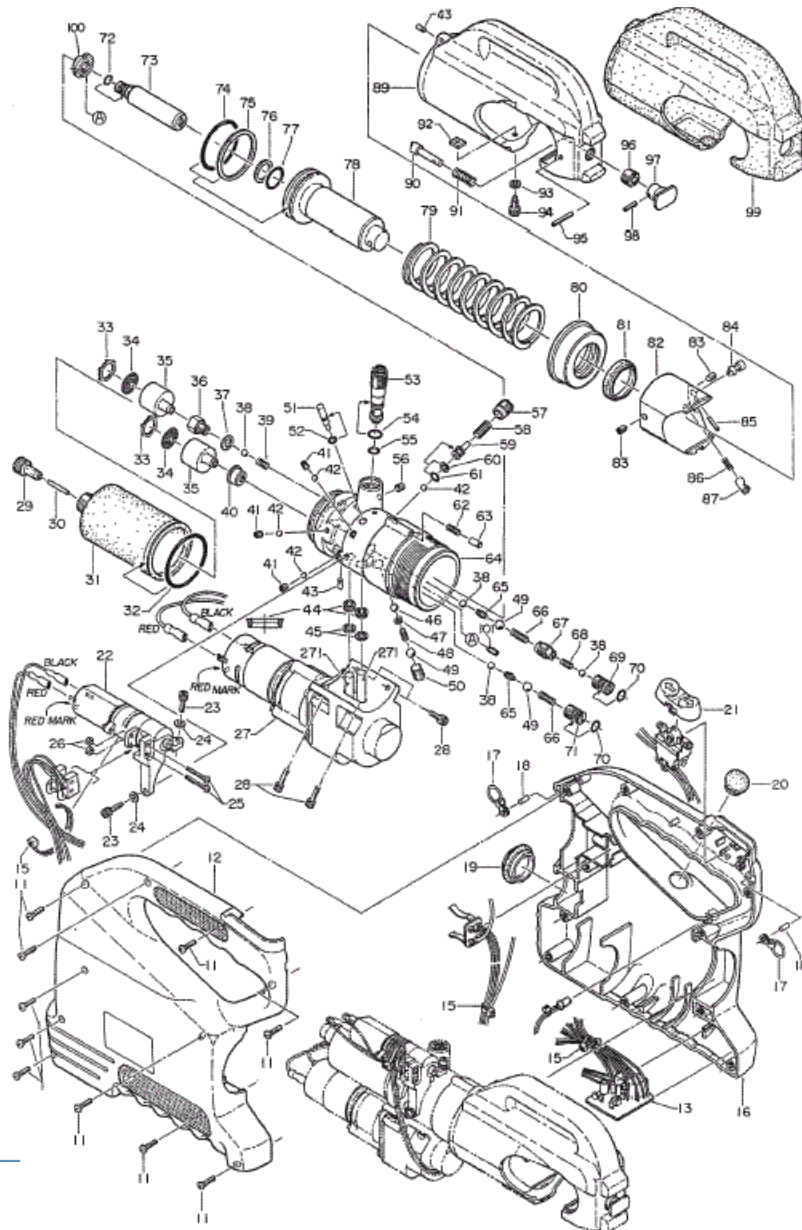

NO.	DESCRIPTION	CODE	QTY.	NO.	DESCRIPTION	CODE	QTY.
11	M4 X 15 Screw	R150-01	10	60	P-5 Back-Up Ring (B.C.)	E3-126	1
12	Housing (R)	351-01	1	61	P-5 O-Ring	5N-35	1
13	Control Unit	351-02	1	62	Spring (371)	51-17	1
15	Binder	HR-30	3	63	Stopper Pin	351-16	1
16	Housing (L)	351-03	1	64	Body	351-17	1
17	Hanging Ring Ass'y	ROB-101A	2	65	Spring (66)	85-40	2
18	4 X 12 Parallel Pin	351-04	2	66	Spring (67)	85-30	2
19	Oil Feed Cap	351-05	1	67	Valve Screw (2)	351-18	1
20	Cartridge Cap	ROB-103	1	68	Spring (340)	51-27	1
21	Switch Knob	351-06	1	69	Valve Screw (3)	351-19	1
22	Release Unit	351-07	1	70	P-7 O-Ring	16-60	2
23	M4 X 10 Screw	351-08	2	71	Valve Screw (1)	R510A-09	1
24	M4 Flat Washer	16-81	2	72	S-5 O-Ring	351-20	1
25	M2.3 X 25 Screw	ROB-86	2	73	Inner Pipe	351-21A	1
26	M2.3 Hex Nut	P500-22	2	74	P-41 O-Ring	L100-23	1
27	Power Unit	351-09	1	75	P-41 Back-Up Ring (B.C.)	16B-04	1
28	M4 X 14 Screw (Ni)	ROB-128B	4	76	P-16 Back-Up Ring (B.C.)	22-24	1
29	Reservoir Cap	410-55	1	77	P-16 O-Ring	22-25	1
30	Magnet	ROB-25	1	78	Ram	351-22B	1
31	Oil Reservoir (37)	351-10	1	79	Ram Spring (644)	351-29	1
32	P-40 O-Ring	700S-27	1	80	Guide Ring	351-24	1
33	SI-20 Ring	410-74	2	81	SER-30 Scraper	R510-03	1
34	Filter Screen	410-73	2	82	Ram Head	351-25A	1
35	Strainer	9H-43A	2	83	M5 X 8 Screw (C.P.)	P55A-02	2
36	Strainer Bushing (1)	351-11	1	84	Die Release Pin	430-21	1
37	Copper Gasket (20)	100W-17	1	85	2.5 X 14 Drive Pin (BW)	410-11	1
38	3/16" Ball	16-49	4	86	Spring (177)	410-01	1
39	Spring (340)	51-27	1	87	Retainer Pin (B)	410-12	1
40	Strainer Bushing (2)	ROB-82	1	89	Head	351-27	1
41	M5 X 5 Screw (F.P.)	510A-05	3	90	Retainer Pin (A)	510-04	1
42	5/32" Ball	22-21	4	91	Spring (257)	510-03	1
43	3 X 8 Dowel Pin (D)	610F-11	2	92	Key	510A-06	1
44	PS-8 Pent Seal	16-44	2	93	M5 Lock Washer (Small)	510-12	1
45	P-8 Back-Up Ring (B.C.)	85-33	2	94	Guide Screw	510A-15	1
46	7/32" Ball	16-26	1	95	2.5 X 25 Drive Pin (BW)	410-04	1
47	M3 Flat Washer	16-38	1	96	Screw (16)	510-02	1
48	Spring (76)	16-39	1	97	Die Release Knob	510-01B	1
49	9/32" Ball	16-40	3	98	2 X 12 Drive Pin (BW)	351-28	1
50	M10 X 12 Screw (F.P.)	40-47	1	99	Head Insulation	510B-33	1
51	Release Pin	351-12	1	100	Stopper Nut	351-30	1
52	P-3 O-Ring	16-36	1	101	M4 X 10 Screw	46M-04	1
53	Valve Cartridge	R510-18A	1	271	Pump Piston (2)	P500-10	2
54	S-9 O-Ring	410-71	1				
55	P-8 O-Ring (B)	700S-15	1				
56	M5 X 5 Screw	300-73	1				
57	Valve Screw (4)	351-13	1				
58	Spring (595)	351-14	1				
59	Reduction Valve	351-15	1				



# UTILUX | SPARE PARTS LIST

Product - #REC 50U

Description - Battery Operated Cable Cutter

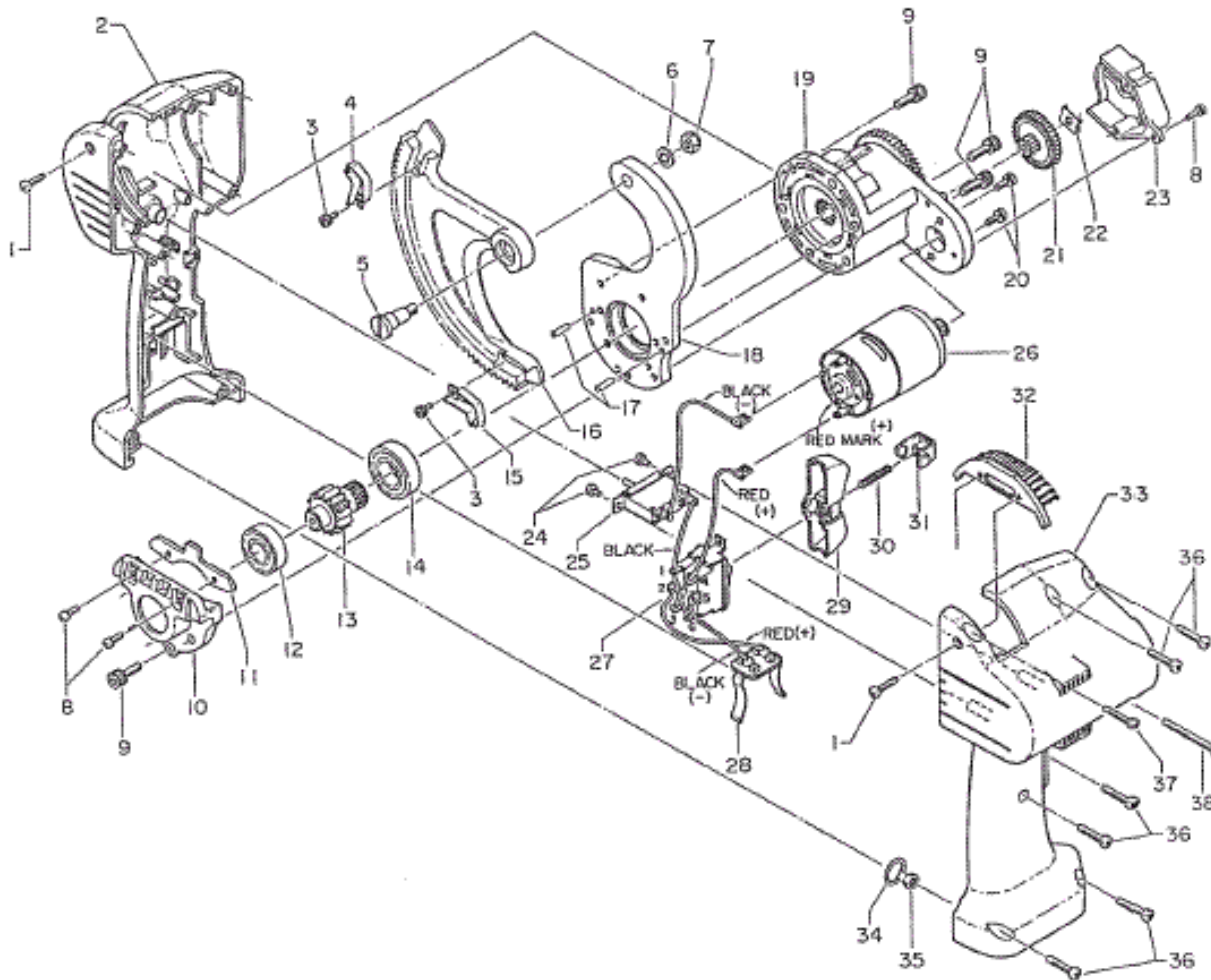

NO.	DESCRIPTION	CODE	QTY.
1	M3 X 14 Screw (T.P.)	RC50-01	2
2	Housing (L)	RC50-02	1
3	M3 X 3 Screw	RC50-03	2
4	Gear Guide (B)	RC50-04	1
5	Shoulder Screw	RC50-05	1
6	M6 Lock Washer (Ni)	RC50-06	1
7	M6 Lock Nut	RC50-07	1
8	M3 X 8 Screw	RC50-08	5
9	M5 X 14 Screw	RC50-09	11
10	Bearing Case	RC50-10	1
11	Cutler Plate	RC50-11	1
12	Bearing 6001	RC50-12	1
13	Pinion Gear	RC50-13	1
14	Bearing 6002	RC50-14	1
15	Gear Guide (A)	RC50-15	1
16	Moving Blade	RC50-16	1
17	Needle Pin	RC50-17	2
18	Stationary Blade	RC50-18	1
19	Gear Case Ass'y	RC50-19	1
20	M4 X 8 Screw	RC50-20	2
21	Gear	RC50-21	1
22	Gear Plate	RC50-22	2
23	Gear Cover	RC50-23	1
24	Retaining Pin (C.P.)	RC50-24	2
25	Circuit Breaker	RC50-25	1
26	Motor	RC50-26	1
27	Switch	RC50-27	1
28	Contact	RC50-28	1
29	Switch Knob	RC50-29	1
30	Spring (524)	RC50-30	1
31	Switch Lock	RC50-31	1
32	Brush	RC50-32	1
33	Housing (R)	RC50-33	1
34	Hanging Ring	ROB-101	1
35	Ring Support	ROB-120	1
36	M4 X 20 Screw (T.P.)	ROB-29	6
37	M3 X 20 Screw (T.P.)	RC50-37	1
38	M4 X 40 Screw (T.P.)	ROB-126	1

**tyco**

Electronics

Energy Division



# UTILUX | SPARE PARTS LIST

Product - #CCSP55

Description - Hydraulic Cable Cutter Head

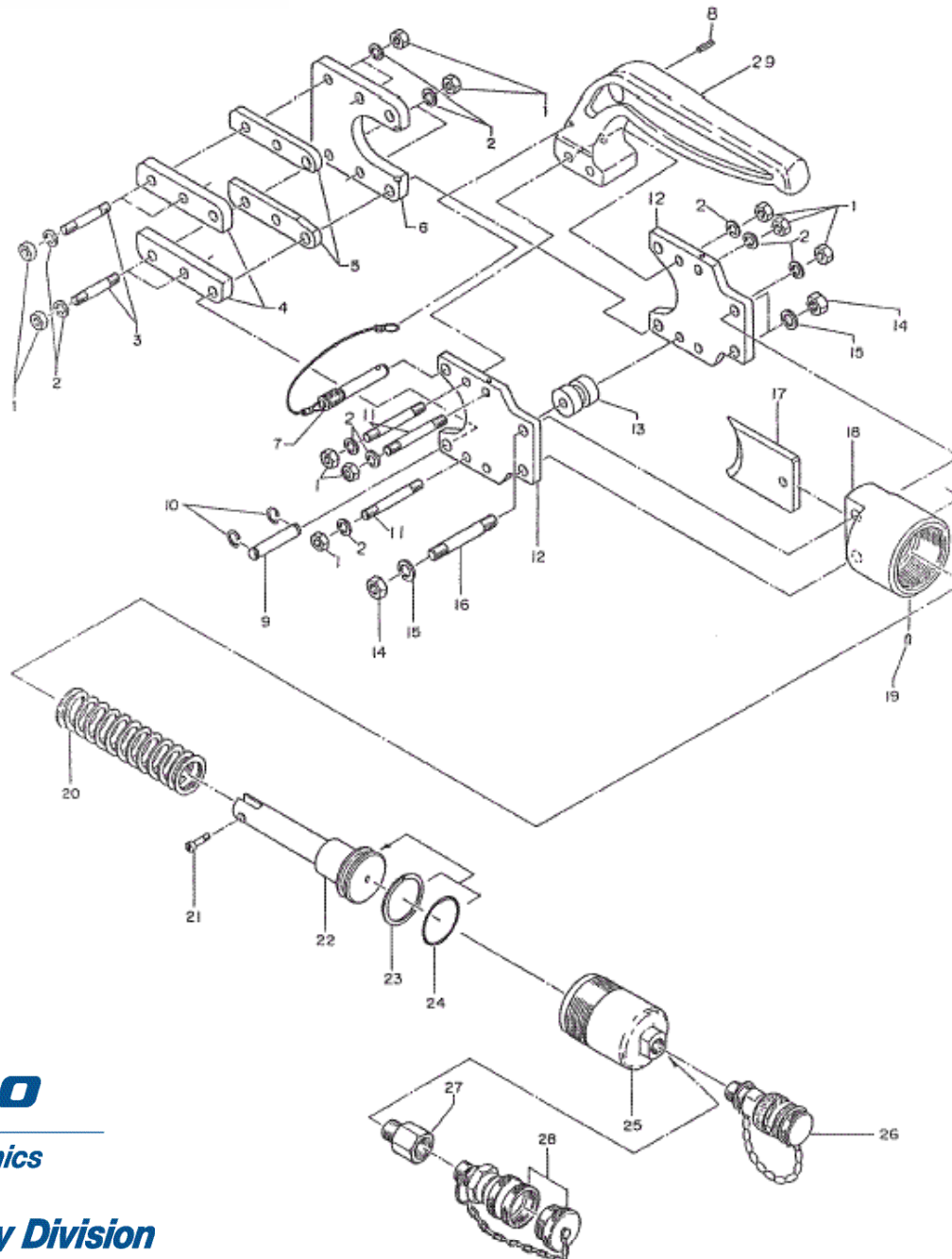

NO.	DESCRIPTION	CODE	QTY.
1	M10 Hex. Nut	40-31	14
2	M10 Lock Washer	40-32	14
3	Stud Bolt (7)	55-01	4
4	Head Shear Plate	55-02	2
5	Spacer	55-03	2
6	Head Shear	55-04	1
7	Lock Pin Assy	55E-01	1
8	3 X 20 Drive Pin (AW)	P55-06	1
9	Pin (48)	55-08	1
10	CE-12 Snap Ring	55-09	2
11	Stud Bolt (8)	55-10	3
12	Support Plate	55E-03	2
13	Roller	55-13	1
14	M12 Hex. Nut	55-14	4
15	M12 Lock Washer	40-09	4
16	Stud Bolt (15)	55-15	2
17	Blade	55-16	1
18	Cylinder Head	P55A-01	1
19	M4 X 5 Screw (C.P.)	55A-24	1
20	Ram Spring (104)	P55-02	1
21	Blade Screw	55-19	1
22	Ram	P55-03	1
23	P-46 Back-Up Ring (B.C.)	P55-04	1
24	P-46 O-Ring	P55-05	1
25	Cylinder	P55A-03	1
26	Female Coupler IZUMI	100-24	1
27	Adapter 3/8" PT-M. 3/8" NPT-F.	P85-80	1
28	Female Coupler P.H. Type	P85-81	1
29	Carrying Handle	P55-07	1

**tyco**

Electronics

Energy Division



# UTILUX | SPARE PARTS LIST

Product - #CCSP100

Description - Hydraulic Cable Cutter Head

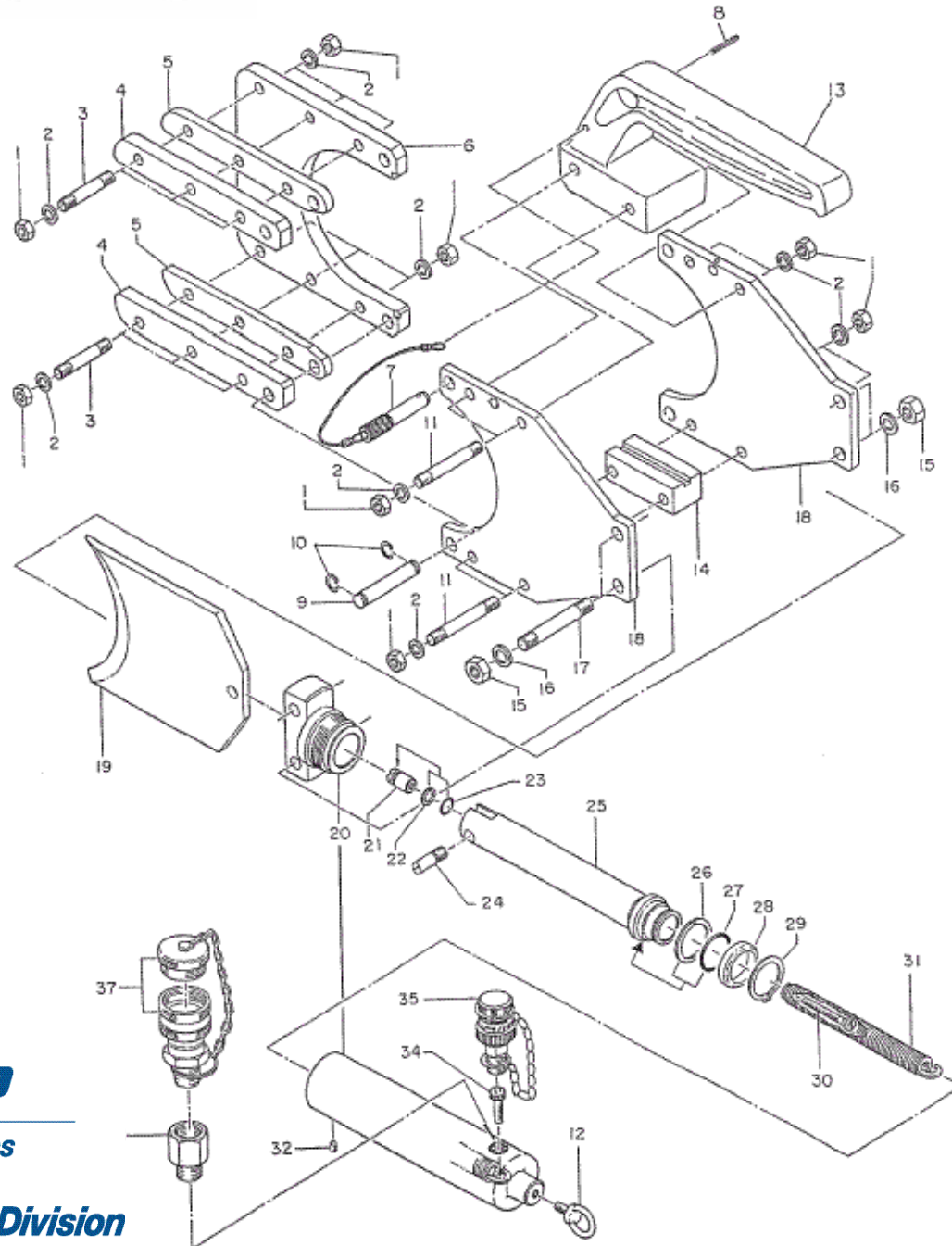

NO.	DESCRIPTION	CODE	QTY.
1	M10 Hex. Nut	40-31	20
2	M10 Lock Washer	40-32	20
3	Stud Bolt (11)	100-01	6
4	Head Shear Plate	100-02	2
5	Spacer	100-03	2
6	Head Shear	100-04	1
7	Lock Pin Ass'y	55E-01	1
8	3 X 20 Drive Pin (AW)	P55-06	1
9	Pin (48)	55-08	1
10	CE-12 Snap Ring	55-09	2
11	Stud Bolt (8)	55-10	4
12	M8 Lifting Bolt	100-05	1
13	Carrying Handle	P100A-01	1
14	Guide Piece (B)	P100A-02	1
15	M12 Hex. Nut	55-14	4
16	M12 Lock Washer	40-09	4
17	Stud Bolt (15)	55-15	2
18	Support Plate	100A-02	2
19	Blade	100-10	1
20	Cylinder Ass'y	100A-06A	1
21	Spring Anchor Stub	100-12	1
22	P-10 Back-Up Ring (B.C.)	100-13	1
23	P-10 O-Ring	100-14	1
24	Blade Screw	100-16	1
25	Ram	100-18	1
26	P-34 Back-Up Ring (B.C.)	85-22	1
27	P-34 O-Ring	85-23	1
28	Flange	100A-03	1
29	G-30 Snap Ring	100A-04	1
30	Spring Anchor Screw (A)	100-19	1
31	Ram Spring (230)	100A-05	1
32	M6 X 6 Screw (C.P.)	85-41	1
34	M8 X 25 Screw	100-23	1
35	Female Coupler IZUMI	100-24	1
36	Adaptor 3/8" PT-M. 3/8" NPT-F.	P85-80	1
37	Female Coupler P.H. Type	P85-81	1

**tyco**

Electronics

Energy Division



# UTILUX | SPARE PARTS LIST

**Product - #CCS20A**  
**Description - Hand Operated Hydraulic Cable Cutter**

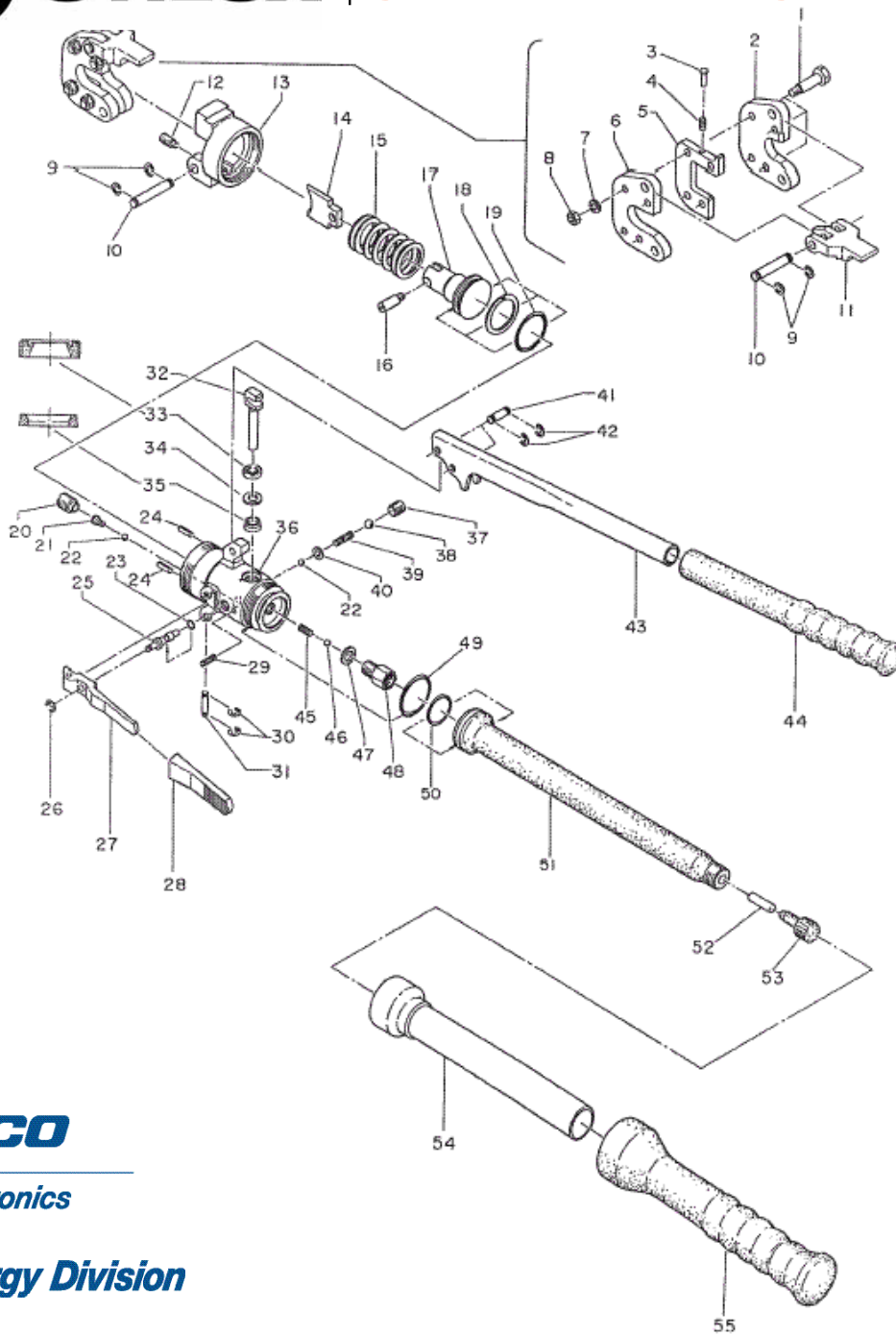

NO.	DESCRIPTION	CODE	QTY.	NO.	DESCRIPTION	CODE	QTY.
1	Shoulder Bolt	16-03B	4	49	S-36 O-Ring	86-51	1
2	Head Shear	20-02	1	50	P-26 O-Ring	16-55	1
3	Slide Pin	20-71	1	51	Oil Reservoir (4)	20A-03	1
4	Spring (144)	85-37	1	52	Magnet	ROB-25	1
5	Spacer	20-70	1	53	Reservoir Cap	410-55	1
6	Main Head	20-04	1	54	Body Handle	16-63	1
7	M6 Lock Washer	16-02	4	55	Body Handle Grip	20-11	1
8	M6 Hex. Nut	16-01	4				
9	CE-8 Snap Ring	16-09	4				
10	Pin (46)	16-10	2				
11	Latch	16-11	1				
12	M5 X 10 Screw (D.P.)	55A-11	1				
13	Body Head	20A-01	1				
14	Blade	20-07	1				
15	Ram Spring (75)	16-17	1				
16	Blade Screw	16-19	1				
17	Ram	16-21	1				
18	P-29 Back-Up Ring (B.C.)	16-22	1				
19	P-29 O-Ring	16-23	1				
20	Valve Screw (3)	16-24	1				
21	Spring (2)	16-25	1				
22	7/32" Ball	16-26	2				
23	P-3 O-Ring	16-36	1				
24	2.5 X 10 Dowel Pin (D)	40A-03	2				
25	Release Valve Stem	16-35	1				
26	E-3.2 Snap Ring	16-33	1				
27	Release Lever	20-08	1				
28	Release Lever Insulation	20-09	1				
29	Spring (77)	16-37	1				
30	E-2.5 Snap Ring	16-28	2				
31	Pin (26)	16-27	1				
32	Pump Piston	16-47	1				
33	VC8 Oil Seal	40A-05	1				
34	P-8 Back-Up Ring (B.C.)	85-33	1				
35	PS-8 Pent Seal	16-44	1				
36	Body	20A-02	1				
37	M10 X 10 Screw (F.P.)	16-41	1				
38	9/32" Ball	16-40	1				
39	Spring (76)	16-39	1				
40	M3 Flat Washer	16-38	1				
41	Pin (47)	16-29	2				
42	CE-6 Snap Ring	16-30	4				
43	Pump Handle	16-31	1				
44	Pump Handle Grip	20-10	1				
45	Spring (4)	16-48	1				
46	3/16" Ball	16-49	1				
47	Copper Gasket (6)	16-50	1				
48	Suction Valve Screw Ass'y	16-51	1				



# UTILUX | SPARE PARTS LIST

**Product - #CCS40A**  
**Description - Hand Operated Hydraulic Cable Cutter**

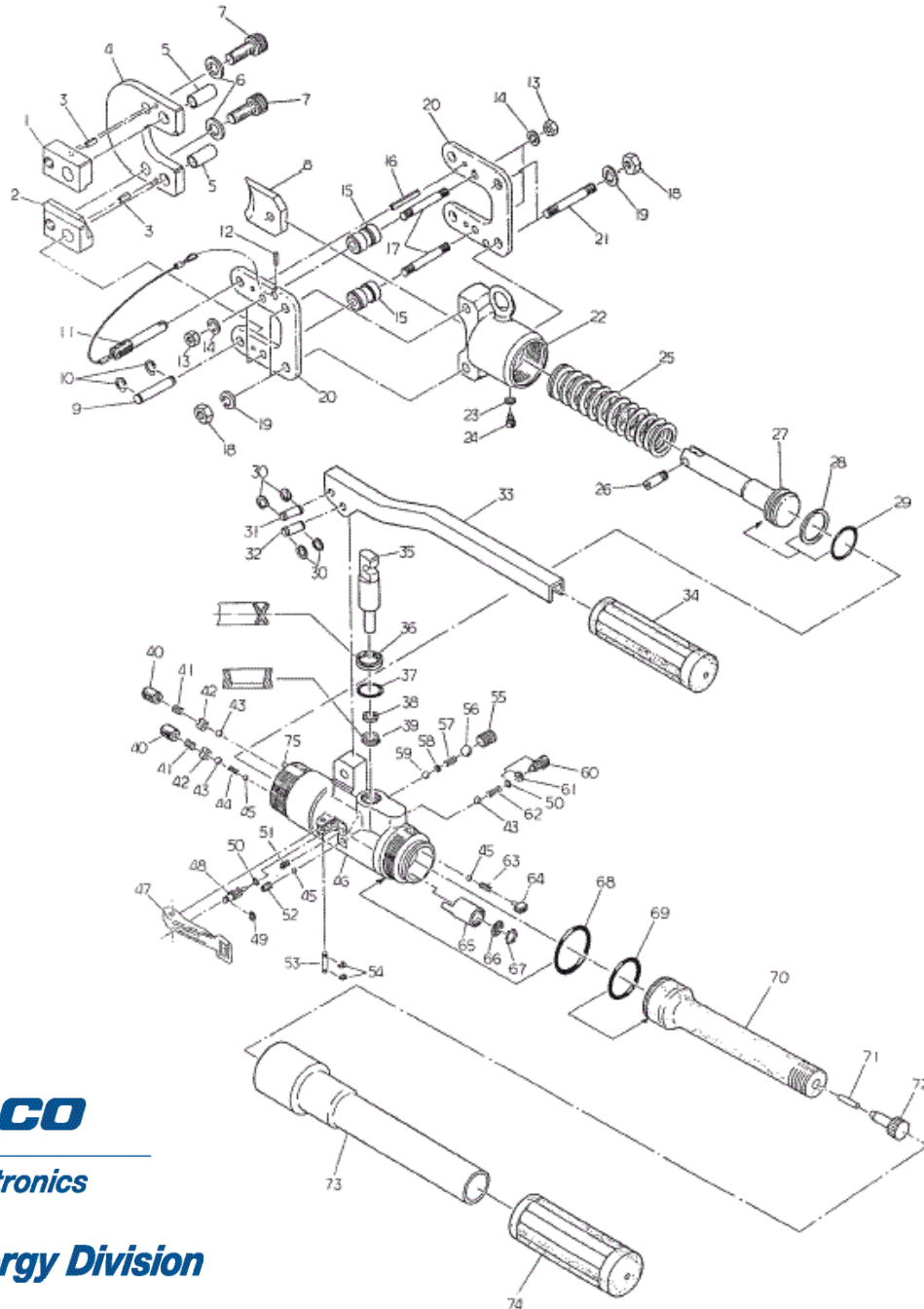

NO.	DESCRIPTION	CODE	QTY.	NO.	DESCRIPTION	CODE	QTY.
1	Guide Piece (A)	40-02	1	49	E-3.2 Snap Ring	16-33	1
2	Guide Piece (B)	40-04	1	50	P-3 O-Ring (C.P.)	UC-27	2
3	3 X 12 Drive Pin (AW)	40-05	2	51	Spring (371)	51-17	1
4	Head Shear	40-07	1	52	M4 X 5 Screw (F.P.)	C58-08	1
5	Bushing	40-12	2	53	Pin (26)	16-27	1
6	M12 Lock Washer	40-09	2	54	E-2.5 Snap Ring	16-28	2
7	M12 X 30 Screw	40-11	2	55	M10 X 12 Screw (F.P.)	40-47	1
8	Blade	40-14	1	56	9/32" Ball	16-40	1
9	Pin (43)	40-15	1	57	Spring (76)	16-39	1
10	CE-10 Snap Ring	40-16	2	58	M3 Flat Washer	16-38	1
11	Lock Pin Ass'y	40-17	1	59	7/32" Ball	16-26	1
12	2 X 12 Drive Pin (AW)	40-21	1	60	Plug	C60-17	1
13	M8 Hex. Nut	40-24	4	61	P-3 Back-Up Ring (B.C.)	9H-38	1
14	M8 Lock Washer	40-25	4	62	Spring (395)	C60-19	1
15	Roller	40-27	2	63	Spring (396)	C60-20	1
16	4 X 40 Drive Pin (AW)	40-28	1	64	Valve Screw (20)	C60-21	1
17	Stud Bolt (17)	40-30	2	65	Strainer	C60-22	1
18	M10 Hex.Nut	40-31	4	66	Filter	C60-23	1
19	M10 Lock Washer	40-32	4	67	SI-15 Ring	C60-24	1
20	Support Plate	40-34	2	68	S-40 O-Ring	C60-25	1
21	Stud Bolt (16)	40-36	2	69	P-28 O-Ring	300-21	1
22	Body Head	40A-01	1	70	Oil Reservoir (22)	40B-04	1
23	M5 Lock Washer	410-09	1	71	Magnet	ROB-25	1
24	Stopper Screw	40A-02	1	72	Reservoir Cap	410-55	1
25	Ram Spring (121)	40-38	1	73	Body Handle Ass'y	40B-05	1
26	Blade Screw	40-40	1	74	Body Handle Grip	40B-06	1
27	Ram	40-42	1	75	2.5 X 10 Dowel Pin (D)	40A-03	2
28	P-32 Back Up Ring (B.C.)	40-43	1				
29	P-32 O-Ring	40-44	1				
30	CE-7 Snap Ring	40-49	4				
31	Pin (158)	C60-06	1				
32	Pin (157)	C60-07	1				
33	Pump Handle	40B-01	1				
34	Pump Handle Grip	51-25	1				
35	Pump Piston	C60-10	1				
36	P-16 X-Ring	C60-11	1				
37	P-16 O-Ring (C.P.)	C60-12	1				
38	P-8 Back-Up Ring (B.C.)	85-33	1				
39	PS-8 Pent Seal	16-44	1				
40	Valve Screw (1)	300-11	2				
41	Spring (227)	300-31	2				
42	Spring Holder	300-32	2				
43	3/16" Ball	16-49	3				
44	Spring (164)	85A-07	1				
45	1/8" Ball	40-20	3				
46	Body	40B-02	1				
47	Release Lever	24-15	1				
48	Release Valve Stem	40B-03	1				