

Instructions for installation, use and maintenance of Scotchflex® Cable Shear Model 3320

Please Note: This unit has been designed specifically for cutting Scotchflex Flat Cable. When used for this purpose it will provide excellent service and require a minimum of maintenance. Due to the specialized nature of the design, it should not be used for cutting other materials.

The 3320 cable shear is supplied with one section of table assembled to the shear and the following accessories:

Qty	Item
1	cable stop
2	tapes (1-U.S. inch; 1-metric)
2	long table support legs (black)
2	short table support legs (red)
4	1/4-20 nuts
2	10 - 32 x 5/8" flathead screws

Press Set-up (figure 1).

1. Remove pressure platen from assembly press.
2. Place a 1/4" thick plate of any rigid material on the assembly press table. Many Scotchflex connector locator plates are 1/4" thick, but thickness must be verified.

3. Adjust any Scotchflex® assembly press to a shut height gauge setting of 15 1/2 following the instructions provided with the assembly press. Use Shut Height Gauge 3436-1A. (Setting is made with the gauge block resting on the 1/4" base plate.)

Shear Installation: (figure 1).

1. Place the shear in the Scotchflex assembly press, locating it over the existing mounting studs.
2. If a more permanent installation is desired, the shear can be fastened down using the two 10-32 x 5/8" flathead screws provided.
 - a. Loosen the cutting board hold down screw and slide the cutting board out.
 - b. Install the two 10-32 x 5/8" flathead screws in the shear in the two remaining holes where the locating pins are **not** showing.
 - c. Replace cutting board and tighten the hold-down screw.

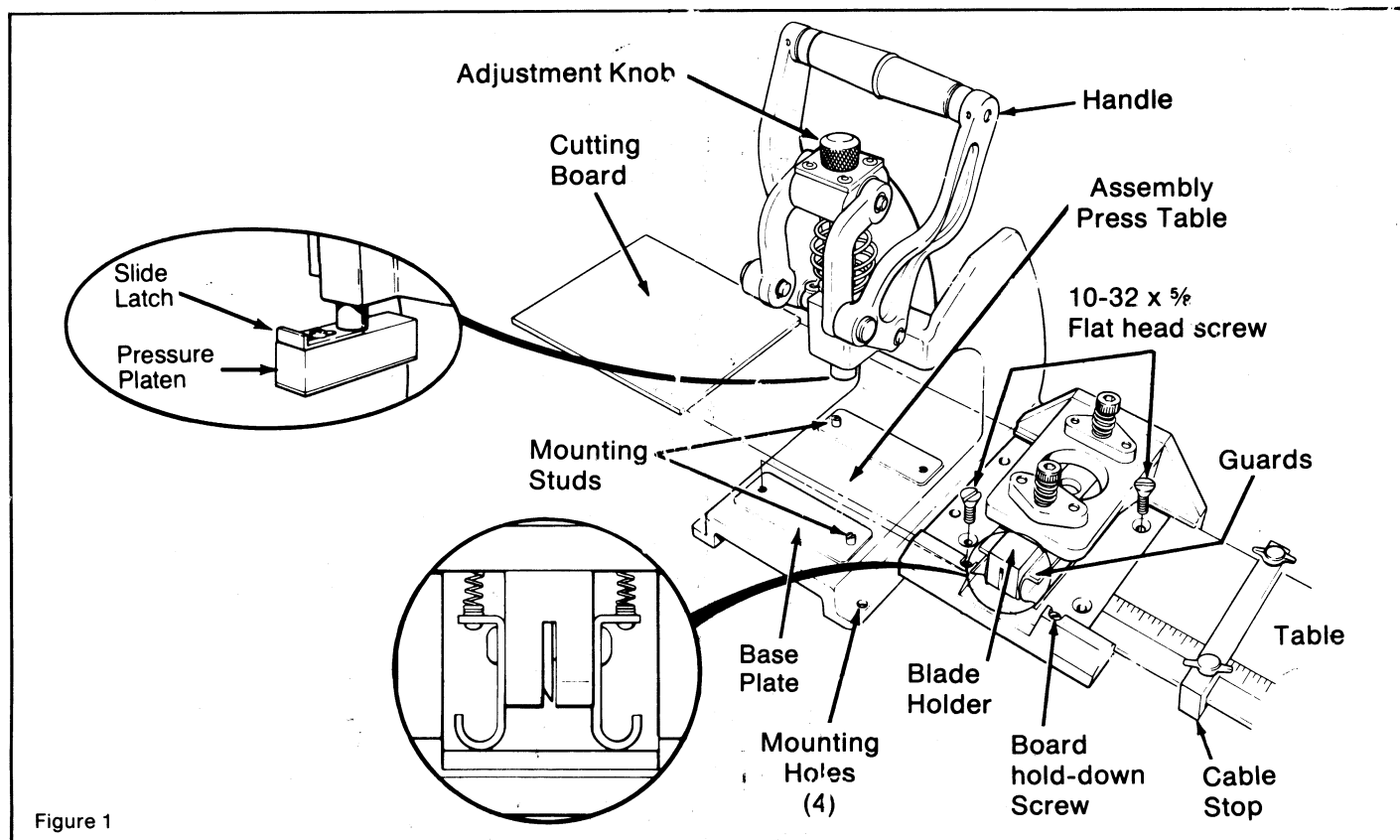

Figure 1

Table Assembly:

The table can be extended to any desired length by adding more 3320-1 table assemblies.

Joining Additional Tables

1. Select the proper table support legs; **long (black)** if the shear is to be used on the 3335 series or 3339 series heavy duty presses, or **short (red)** if the shear is to be used on the 3640 or 3440-A standard assembly press.
2. Thread a 1/4 - 20 nut onto each of the table support legs, down to where approximately 3/8" of thread is exposed beyond the nut (figure 2a).

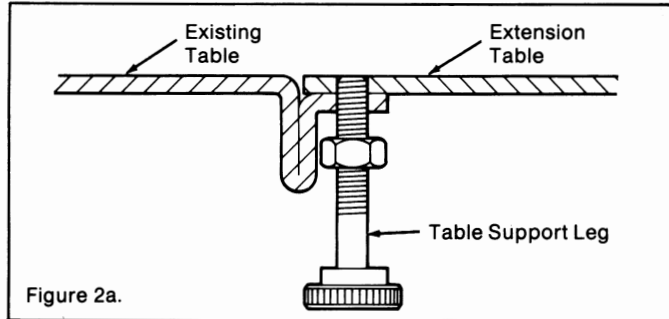

Figure 2a.

3. Place the extension table over the end of the existing table, aligning the mating holes.
4. Thread the table support legs, from the bottom, through the existing table and into the extension table, until the legs are flush with the extension table top.
5. Thread the nuts toward the table and tighten, securing the two tables into place (figure 2b).

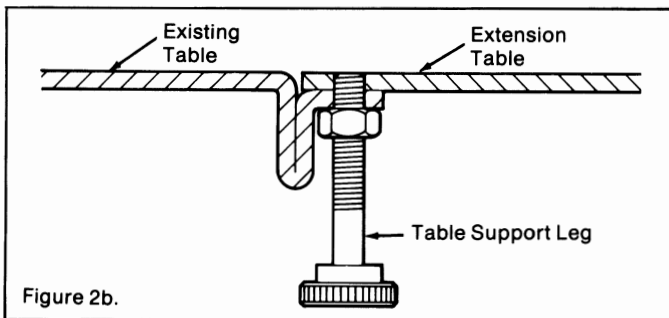

Figure 2b.

6. Repeat steps #1 through #5 for each additional table length.

Assembling Final Table

1. Repeat steps #1 and #2 above.
2. Place the table support legs into the holes at the end of the table.
3. Thread a 1/4 - 20 nut onto the exposed thread of the table support leg and tighten (figure 2c).

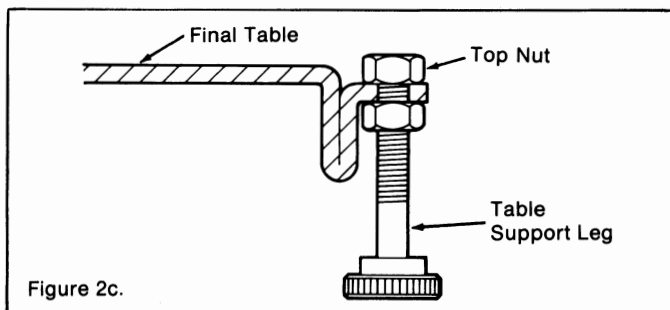

Figure 2c.

Measuring Tape Installation

1. Select desired tape, U.S. inch or metric.
2. Unwind the first 1-1/2 feet (45.72 cm) of tape.
3. Slide the tape under the plastic guards aligning a 12 inch mark (30 cm mark) directly under the blade, at least 1/2 inch (1.27 cm) from either edge of the table (figure 3).

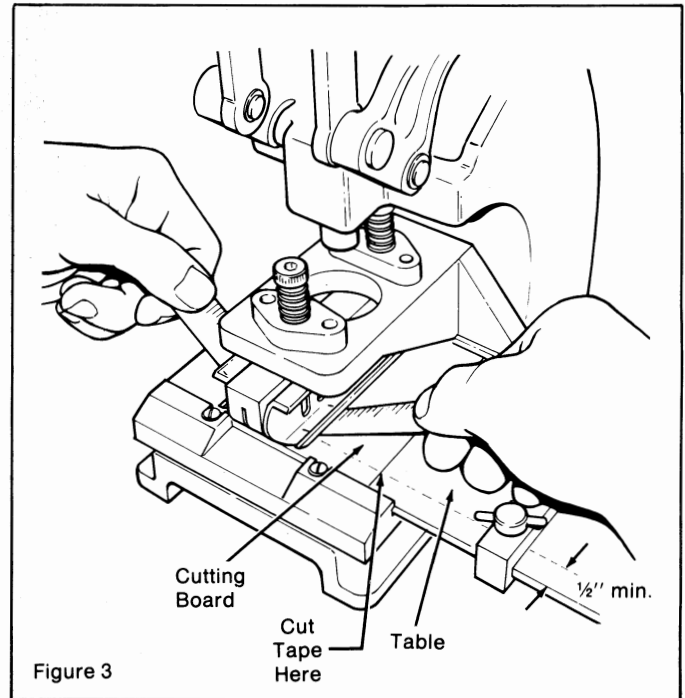

Figure 3

4. Press the tape down onto the table, the length as required by the number of table assemblies installed.
5. Cut the tape along the edge of the table where the cutting board meets the table and remove the tape from the cutting board.

Note: The tape is made with a surface suitable for ink marking so additional numbers can be added as desired.

Operation:

Use:

1. Move the cable stop along the table until the left side is set for the proper cable length; tighten the two set screws.
2. Insert cable from either side or the front of the shear.
3. Guide cable along either the front or rear edge of the shear to obtain proper alignment, assuring a right angle cut.
4. Depress the assembly press handle until the arms stop against the casting. **If the cable is not fully sheared or excessive pressure is required, fine-tune the shut height setting to correct.**
5. Subsequent cuts can be made by feeding the cable through the shear to the desired length.

Note: When shearing very thick cable, it is necessary to use the incoming cable to push the cut cable out so the plastic guard does not drop. If a problem is encountered in inserting cable from side, insert from the front.

Maintenance:

Cutting Board (Replacement Board 3457-1A)

1. When a clean cut is no longer obtainable, loosen the cutting board hold down screw, move the board $1/16''$ to the left and tighten the screw. The board can also be turned 180° for more use of one side, then turned over and the procedure repeated.
2. Replacement boards are available and can be installed as in #1 above.

Cutting Blade (Replacement Blade 3449-1A)

1. Depress the assembly press handle until the arms stop against the casting. The two set-screws are now visible through the plastic guard on the right side of the blade holder.
2. With a $3/32''$ allen wrench, loosen the two set screws (figure 4).
3. Release the assembly press handle and remove the old blade.
4. With the press handle most of the way down, slide a new blade into the slot from the front. (Use the old blade to push the new one into place, centering the blade over the cutting board.)
5. When blade is properly located, depress the press handle until the arms stop against the casting.
6. Tighten the two blade holding set screws.

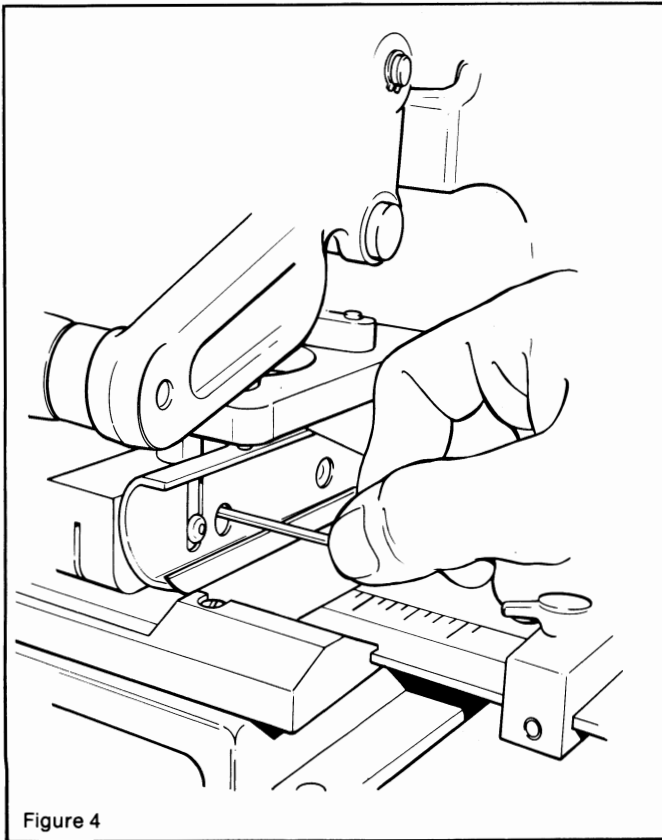

Figure 4

Important Notice to Purchaser:

All statements, technical information and recommendations contained herein are based on tests we believe to be reliable, but the accuracy or completeness thereof is not guaranteed, and the following is made in lieu of all warranties expressed or implied:

Seller's and manufacturer's only obligation shall be to replace such quantity of the product proved to be defective. Neither seller nor manufacturer shall be liable for any injury, loss or damage, direct or consequential, arising out of the use or the inability to use the product. Before using, user shall determine the suitability of the product for his intended use, and user assumes all risk and liability whatsoever in connection therewith.

No statement or recommendation not contained herein shall have any force or effect unless in an agreement signed by officers of seller and manufacturer.

