

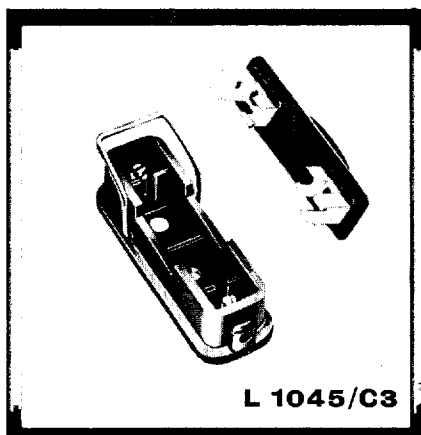

Fuseboxes

size 0



L 1045/C3



L 1033/C4

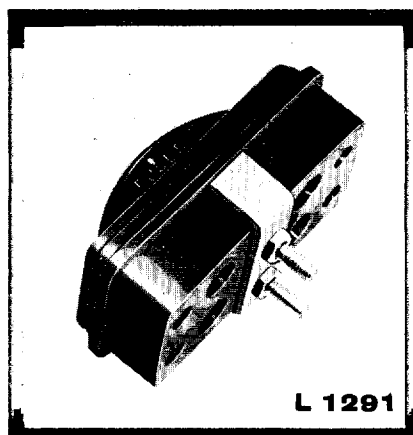

L 1291

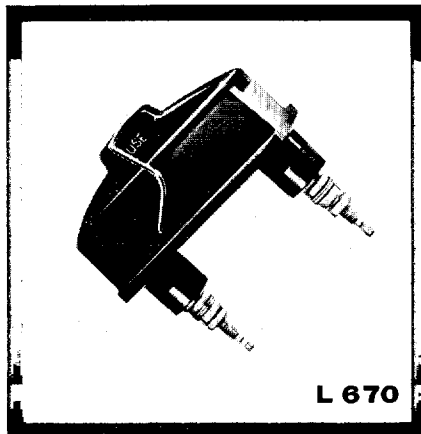

L 670

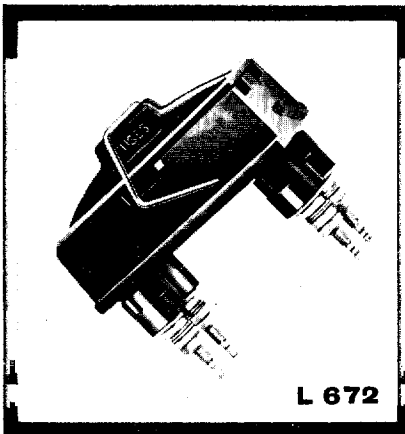

L 672

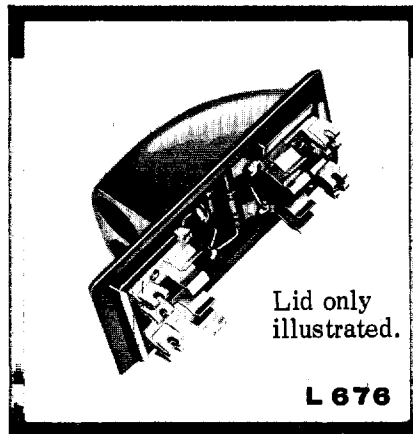

Lid only
illustrated.

L 676

L 1045/C3 Fusebox, single pole

L 1033/C4 Double pole version

Suitable for chassis or panel mounting, these fuseboxes accept standard $1\frac{1}{4} \times \frac{1}{4}$ " fuse links. These are carried in the lid, and are automatically exposed and isolated from the circuit as the lid is raised. Leads may be inserted through the back or through the ends of the box.

L 1291 Fusebox, double pole, semi-recessed

The carrier of this robust component is retained by a central screw which may be wired to discourage unauthorised access. The body is secured by a clamp below the chassis.

Data

Current rating for 40°C temperature rise: 10A

Breakdown (d.c.): between poles $>8\text{kV}$
poles to chassis $>4\text{kV}$

Temperature range: -40° to $+90^{\circ}\text{C}$

L 670 Fusebox, single pole, sealed

L 672 Double pole version.

These qualification approved components have beryllium-copper fuse clips, precipitation hardened, which provide consistent contact pressure on the fuse links. Technical data is on page E11.

L 676 Fusebox, indicating, double pole, sealed

Similar to L672, but this unit has two neon lamp-holders incorporated, with a resistor network so wired that each lamp is extinguished when the associated fuse link blows. The non-reversible lid also fits the L672 base. Supplied without lamps; GEC type 9 and Hivac type 7L are suitable.

Data: See page E11.

Fuseboxes

size 0



DIMENSIONS

Cut-outs minima, normal tolerance +0.005"
Overall sizes and fixing centres nominal.
Figures in brackets are approx. mm equivalents.

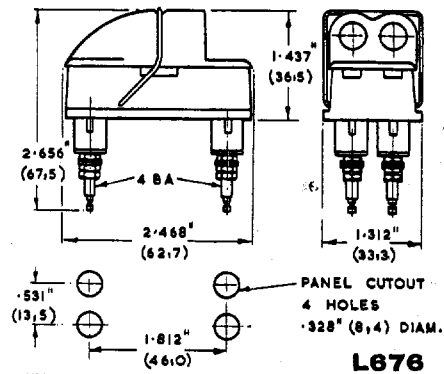
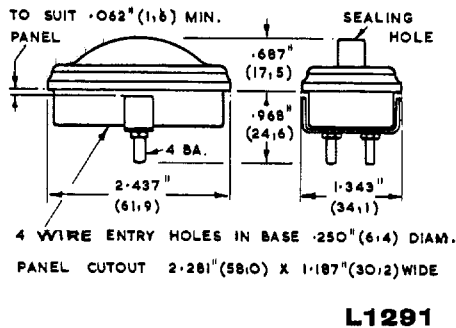
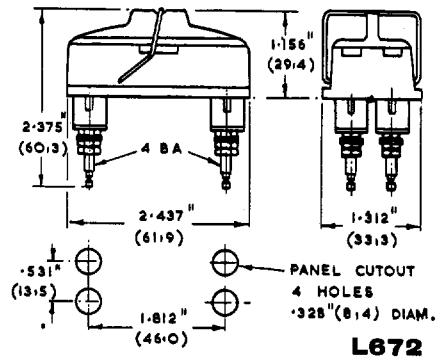
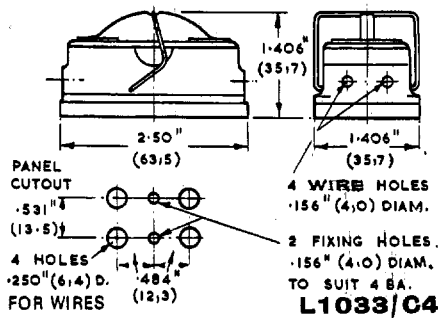
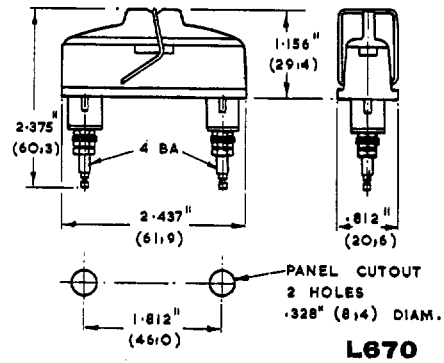
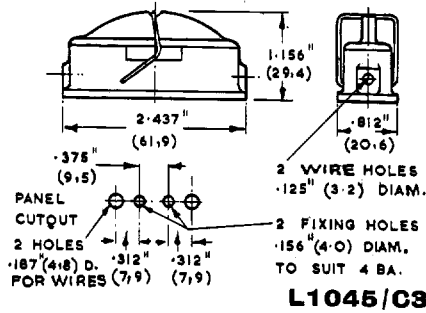

Belling Lee Reference No.	L 670 and L 672		L 676
Specification: [*]	DEF.64		—
Current Rating:	>7A		10A
Breakdown Voltage (d.c.):	at sea level—at 18000m (60,000 ft)		sea level—18000m
Between Poles:	10kV	>1kV	2kV <900V
Poles to Chassis:	>7kV	>1kV	8kV >1kV
Insulation Resistance:	>100 megohms		>10 ³ megohms
Insertion Resistance (per pole):	<20 milliohms		<10 milliohms
Humidity:	Class H ₂ (DEF.5011)		—
Temperature Range:	-55°C to +70°C		—
Panel Thickness (max.):	3,2mm (0.125 in)		3,2mm (0.125 in)
Weight (average):	L670, 36g (1.1 oz) L672, 65,2g (2.3 oz)		77,9g (2.7 oz)

^{*}Temperature rise † 40°C