

PEAK PROGRAMME METERS ME12/9-10

Author M.J. Rawley
First issue January 1979

AMENDMENT RECORD

Amendment no.	Remarks	Amended by	Date
1			
2			
3			
4			
5			
6			
7			
8			
9			
10			
11			
12			
13			
14			
15			
16			
17			
18			
19			
20			

Published by Technical Publications Section,
BBC Engineering Training Department, Wood Norton,
Evesham, Worcestershire, WR11 4TF

First Published 1979

© British Broadcasting Corporation 1979
All rights reserved. No part of this publication may be
reproduced, stored in a retrieval system, or transmitted,
in any form or by any means, electronic, mechanical,
photocopying, recording or otherwise, without the
permission of the British Broadcasting Corporation.

Printed in Great Britain by The Print Unit, BBC Engineering
Training Department, Wood Norton, Evesham, Worcestershire,
WR11, 4TF.

INTRODUCTION

The ME12/9 and ME12/10 are a monophonic peak programme meter and a stereophonic peak programme meter respectively. They each comprise a meter and an amplifier. Except for the ME12/9G, the amplifier can be mounted on the rear of the meter.

Variations in the ME12/9 and the ME12/10 are variations only in the types of meter used. These types are illustrated below and details are given in the adjacent Table.

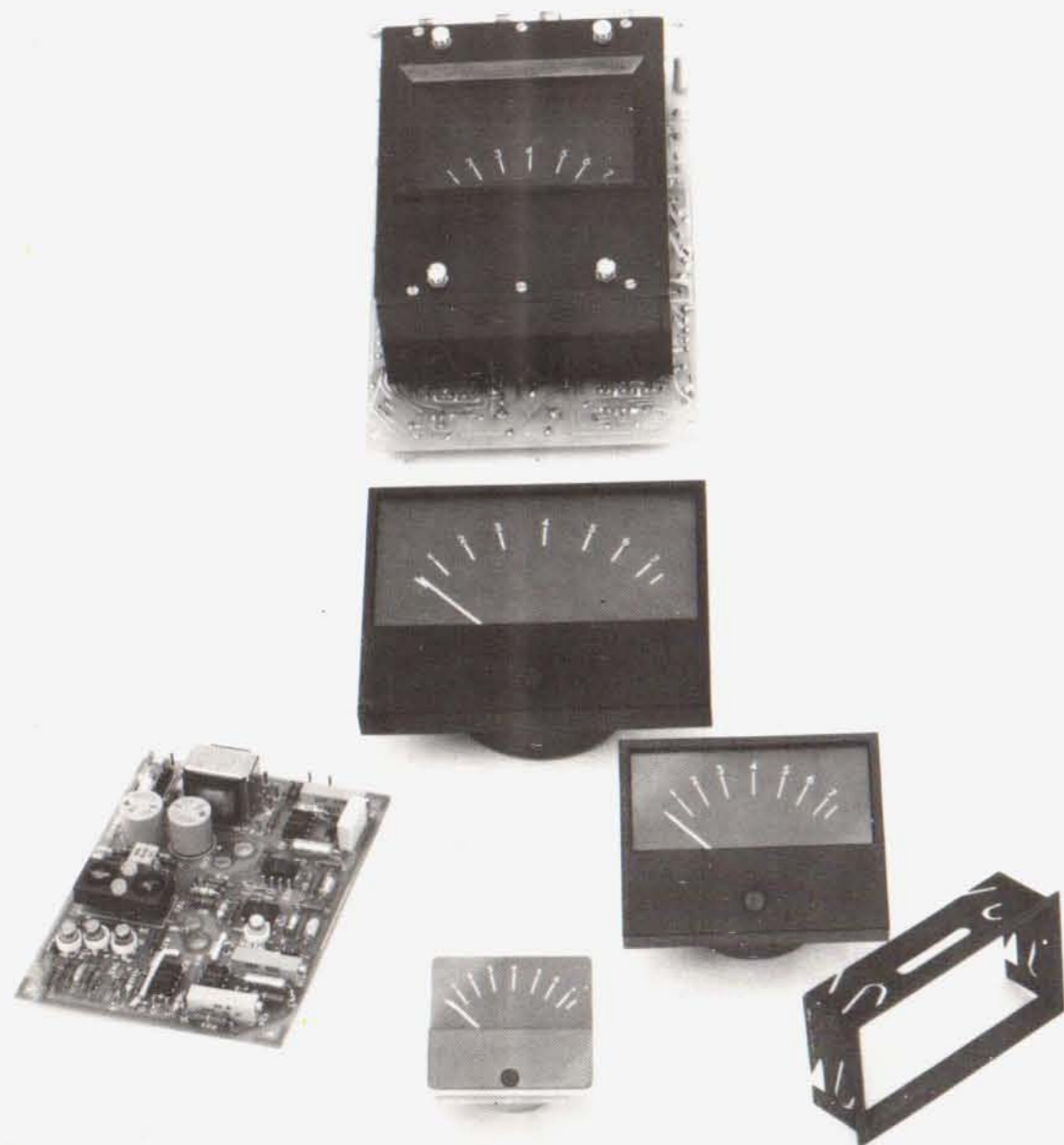

Author M.J. Rawley

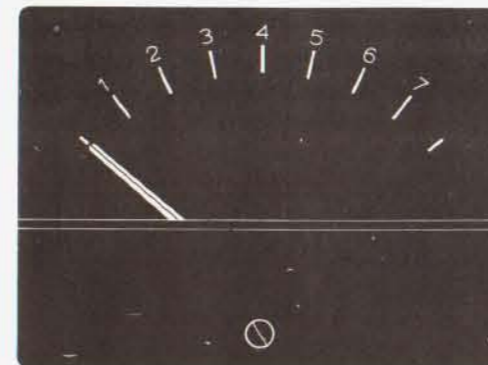

All meters are 1 mA f.s.d. and have a resistance of 600 ohms. The markings occur at the following percentages of f.s.d.

marking	%
1	10
2	22
3	35
4	51
5	67
6	80
7	93

METER TYPES

P.P.M. code	E.D. meter specification	Ernest Turner Type No.	Approximate Size (mm)	Brief description of distinguishing features
ME12/9A	1478	703	105 x 81	Large size – Black plastic case – glass meter panel
ME12/9B	1477	702	73 x 58	Medium size – Black plastic case – glass meter panel
ME12/9C	1499	643	102 x 78	Large size – Transparent all-plastic case
ME12/9D	1498	642	72 x 56	Medium size – Transparent all-plastic case
ME12/9E	1501	903	102 x 78	Large size – Transparent plastic case – glass meter panel
ME12/9F	1500	902	72 x 56	Medium size – Transparent plastic case – glass meter panel
ME12/9G	1497	640	46 x 40	Small size – Transparent all-plastic case
ME12/10A	1502	411 – 848 (ED 1502)	94 x 108	Red and green meter pointers
ME12/10B	1503	411 – 848 (ED 1503)	94 x 108	White and yellow meter pointers

CONTENTS

	page
Introduction	1
Meter types	1
ME12/9 (AM20/3) Functional description	2
Component layout	2
Alignment check	2
Input processing circuit	3
Peak detection circuit description	4
Peak detection circuit	5
Output processing circuit description	6
Output processing circuit	7
ME12/9A-G mounting holes	8
ME12/9 C and D lampholder details	8
ME12/9 A-F assembly	9
ME12/ C and E flush fitting adaptor	10
ME12/9 D and F flush fitting adaptor	11
ME12/10(AM20/4) Component layout	12
Regulation and mode switching	12
Alignment check	13
Required panel cut-out	13
Functional block diagram	14
Simplified A/B: M/S switching circuit	14
Input processing circuit	15
Peak detection circuits	16
Output processing circuits	17

FUNCTIONAL DESCRIPTION

INPUT PROCESSING

Accepts an audio signal at the following levels with respect to zero volume programme:-

- a) 0 dB
- b) -20 dB.
- c) -43 dB*

and produces an output at -6 dB.

*The performance at this input level is restricted.

PEAK DETECTION

Accepts an audio signal at -6 dB with respect to zero volume programme. It produces a direct voltage output equal to the maximum peak voltage of the input. The charge and discharge time constants are selected during manufacture to give the P.P.M. its correct dynamic performance.

OUTPUT PROCESSING

Amplifies the input voltage into an output current with the pseudo-logarithmic law required by the P.P.M. Preset adjustments are provided to give the correct law.

Programme
input



COMPONENT LAYOUT

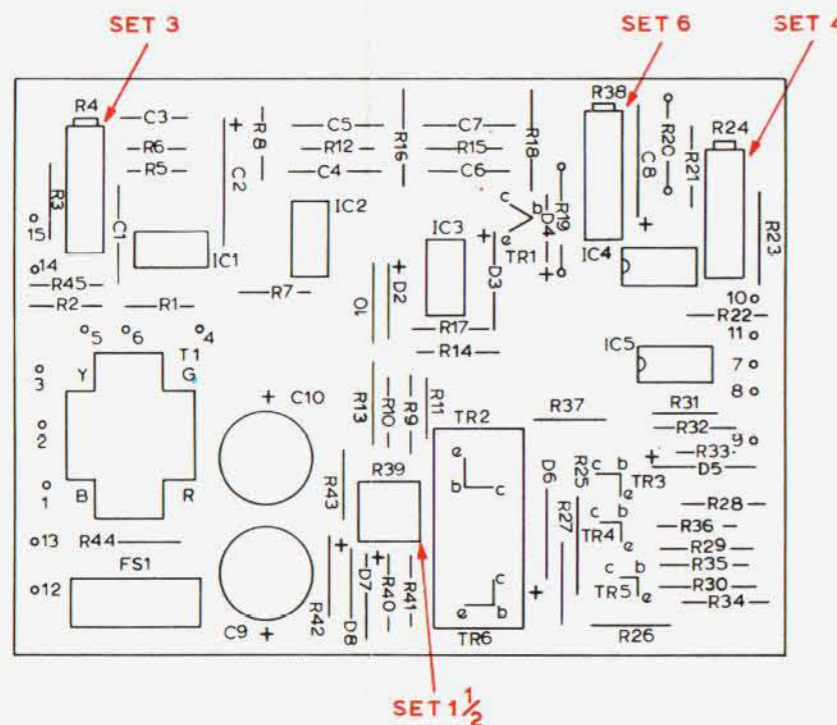

ALIGNMENT CHECK

Normally alignment is not required, but the following checks should be carried out if the meter is changed:

1. Check that, with no power, the mechanical zero of the meter is correct
2. Apply power and terminate the input with 600 ohms. Check that the meter reads zero. If necessary adjust R24
3. Apply 1-kHz tone at -4 dB. Check that the meter reads 3. If necessary adjust R4.
4. Apply 1-kHz tone at +8 dB. Check that the meter reads 6. If necessary adjust R38.
5. Apply 1-kHz tone at -10 dB. Check that the meter reads 1½. If necessary adjust R39.
6. Check that the input levels are within specification for the following meter readings:

1	-12 ± 0.5 dB
2	-8 ± 0.2 dB
3	-4 ± 0.3 dB
4	0 ± 0.2 dB
5	+4 ± 0.3 dB
6	+8 ± 0.2 dB
7	+12 ± 0.5 dB
7. Check that the frequency response is within the following limits:

40 Hz - 20 kHz	0 ± 0.3 dB
10 Hz	-2 ± 0.5 dB
5 Hz	-5 ± 0.8 dB
8. Check that the fallback time of the meter from a reading of 7 to a reading of 1 lies between 2.5 and 3 seconds.
9. If a Peak Programme Meter Tester (e.g. TE1/25) is available check the rise time. Set the level of 5-kHz tone to give a meter reading of 6 and measure the drop in indicated level for the following burst durations:

100 ms	0 ± 0.5 dB
10 ms	-2.5 ± 0.5 dB
5 ms	-4.0 ± 0.75 dB
1.5 ms	-9.0 ± 1.0 dB

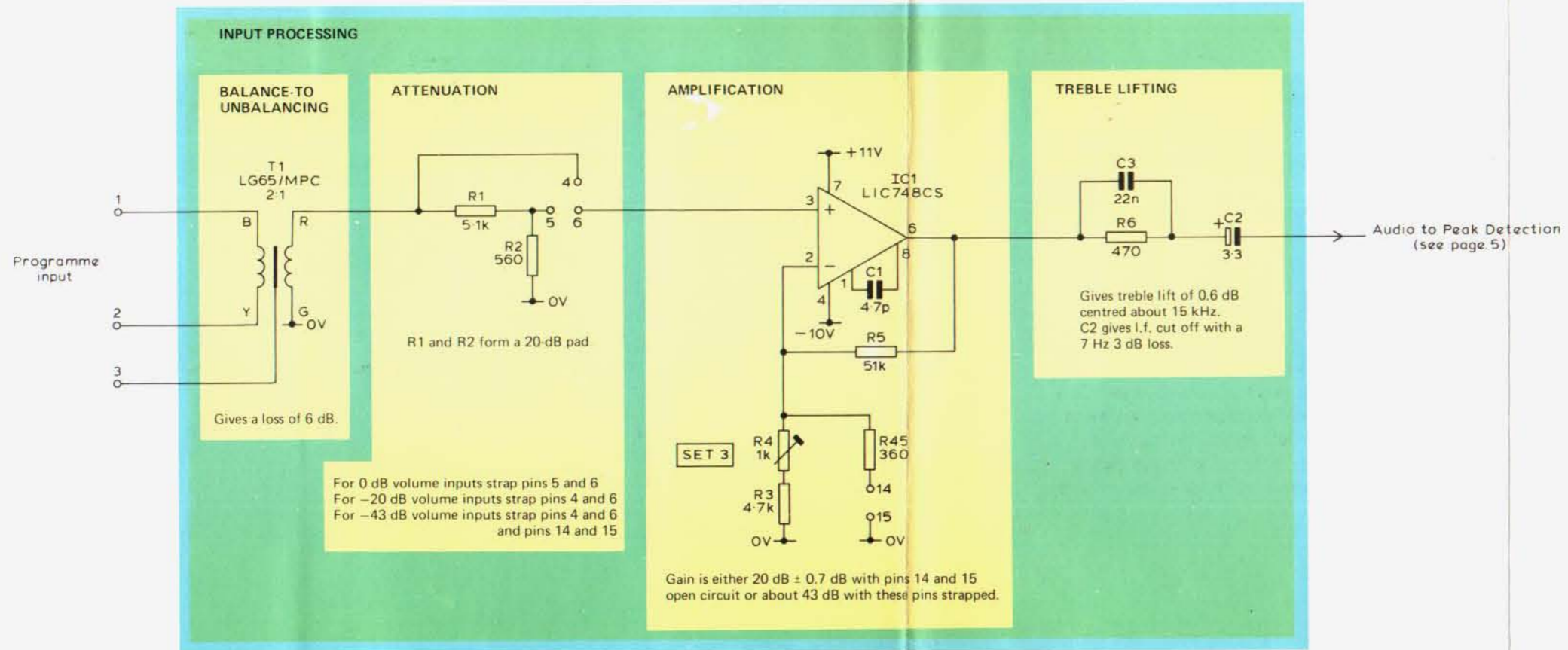

REF	TYPE	BASE
IC1	LIC74BCS	<p>view on top</p>

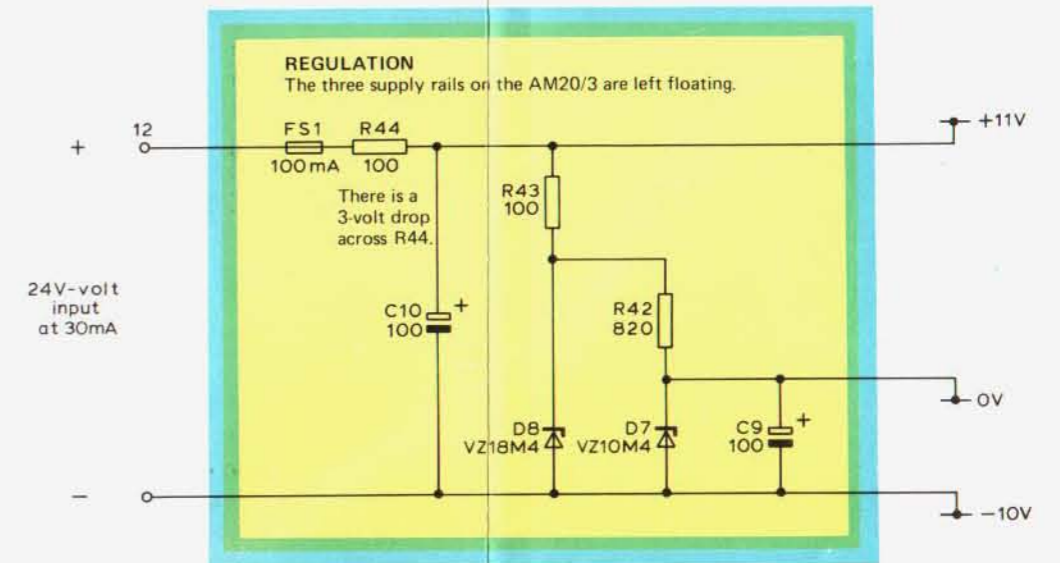

1

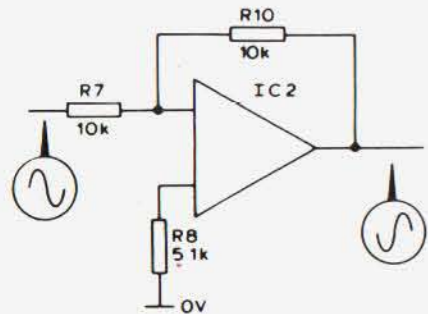

This is a unity-gain inverting op-amp circuit. The gain is given by $R10 \div R7$. The value of R8, equal to R10 in parallel with R7, is chosen to minimise thermal drift.

2

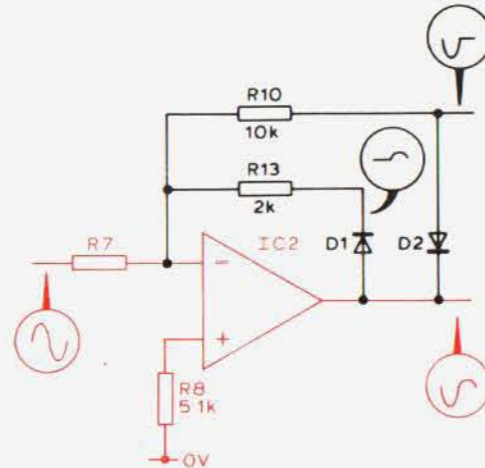

In this circuit the feedback resistor is split into two by means of diodes. This permits different gains on positive and negative half cycles. The high open-loop gain of the op-amp gives a sharp effective knee to the diode characteristics.

3

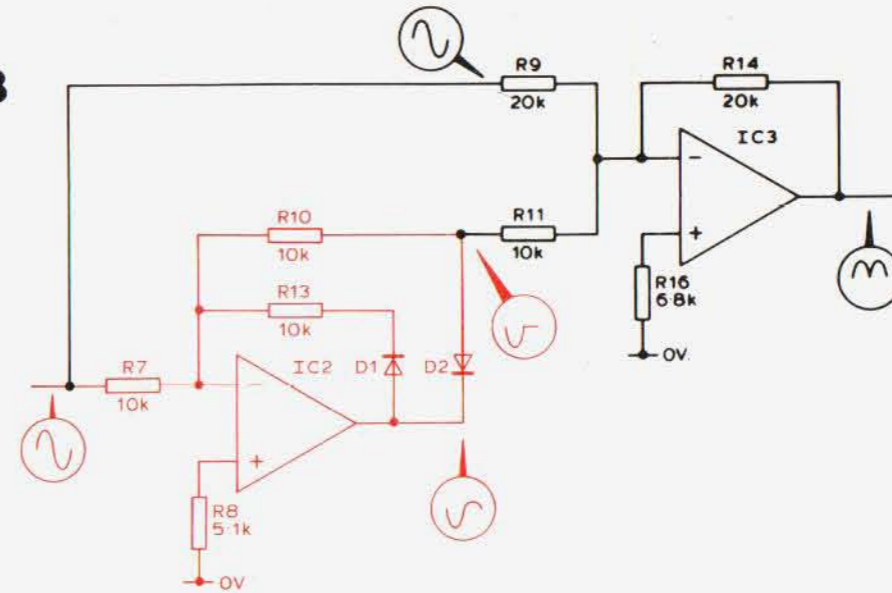

The output of IC3 is the sum of its inputs multiplied by their individual gains, e.g. $o/p = -(a + 2b)$
or $o/p = -\{ \sim + 2 \sim \} = - \sim = \sim$

4

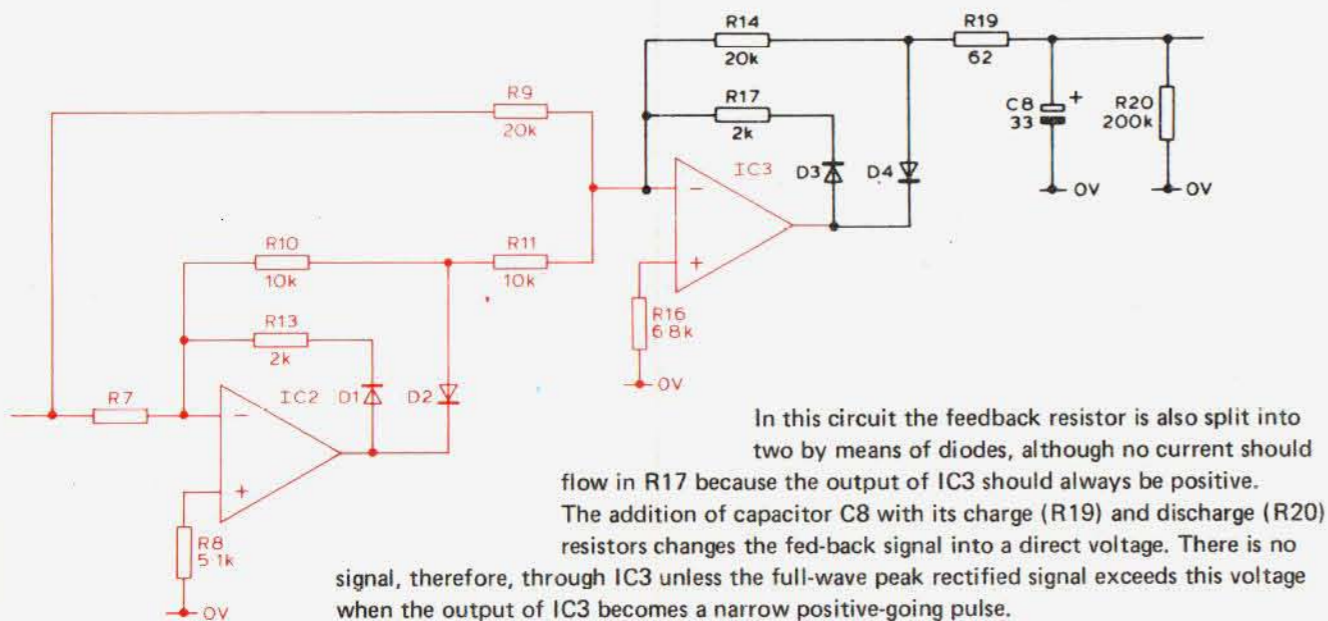

In this circuit the feedback resistor is also split into two by means of diodes, although no current should flow in R17 because the output of IC3 should always be positive. The addition of capacitor C8 with its charge (R19) and discharge (R20) resistors changes the feedback signal into a direct voltage. There is no signal, therefore, through IC3 unless the full-wave peak rectified signal exceeds this voltage when the output of IC3 becomes a narrow positive-going pulse.

5

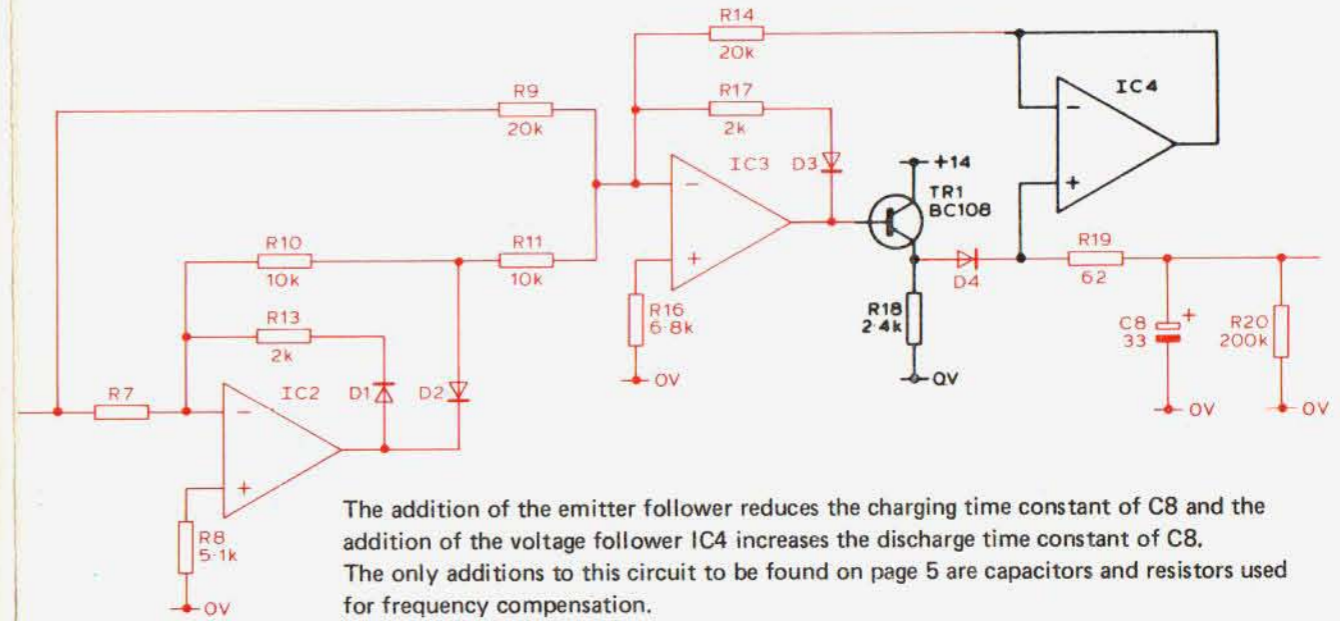

The addition of the emitter follower reduces the charging time constant of C8 and the addition of the voltage follower IC4 increases the discharge time constant of C8. The only additions to this circuit to be found on page 5 are capacitors and resistors used for frequency compensation.

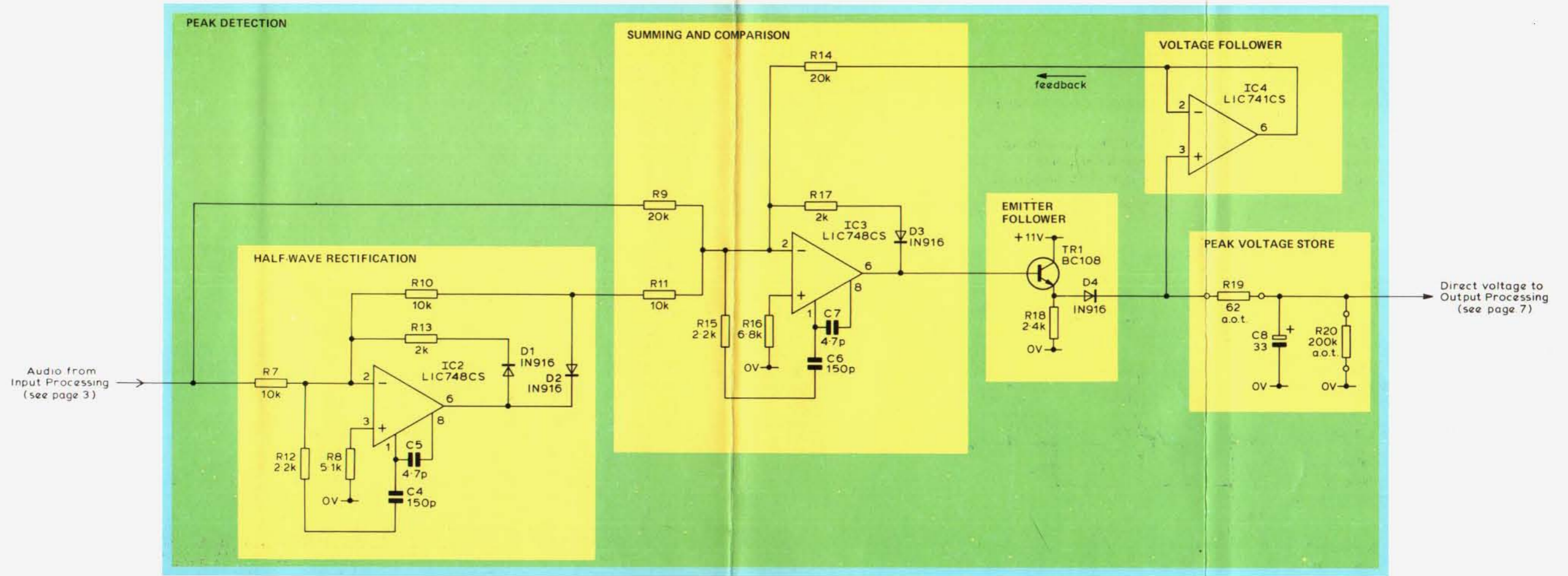

REF	TYPE	BASE
TR1	BC108	 view on base
IC2 IC3	LIC748CS	 view on top
IC4	LIC741CS	 view on top

DESCRIPTION OF PPM LAW CIRCUIT

The gain of IC5 is the ratio of the effective feedback resistance (see circuit blocks a to f) to the input resistance (R21).

The value of the feedback resistance, and hence the gain, varies with the value of the output voltage, as shown in the input/output curves given alongside. The effect of the circuit blocks on gain is described in terms of an output voltage becoming progressively more negative as the PPM input signal increases.

(a) Positive output voltages are inhibited by the use of diode D5.

(b) The circuit of this block modifies the gain over the range $0 \geq V_o \geq -1.1$ volts. A simplified circuit diagram of blocks (b) and (c) is given here and the following points should be noted about this diagram:

1. For the given range in V_o , the diagram is drawn with vertical position corresponding to the voltage.
2. Transistor TR6 is connected as a diode.
3. Transistor TR2 is used with its collector and its emitter reversed. This reduces the gain but is immaterial as the collector current is less than $4 \mu\text{A}$.
4. The open-circuit voltage at the junction of TR6 and R40 in the voltage divider chain, R41, TR6 and R40, is -1.1 volts.

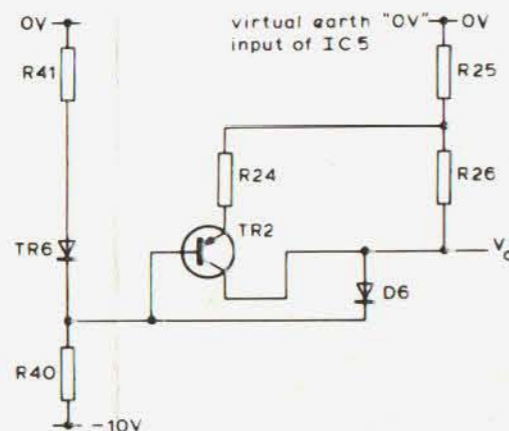

Circuit block (b) affects the gain of IC5 over two ranges:

(b1) $0 \geq V_o \geq -0.4$ volts

Diode D6 is forward-biased pulling V_{TR2b} up to 0.7 volts below V_o . The emitter voltage of TR2 is 0.7 volts more positive, i.e. $V_{TR2e} \approx V_o$, which effectively puts R27 in parallel with R26, giving IC5 a gain of 3.95.

(b2) $-0.4 \geq V_o \geq -1.1$ volts

The forward bias on D6 and the base-emitter junction voltage of TR2 is reduced over this range of V_o and hence the shunting effect of R27 is reduced. The gain of IC5 rises over this range to 5.4.

(c) $-1.1 \geq V_o \geq -2.45$ volts

Resistors R25 and R26 in series give a gain of 5.4.

(d) $-2.45 \geq V_o \geq -3.45$ volts

As V_o becomes more negative, TR5 is brought into conduction as V_o falls to more than 0.7 volts below V_{TR5b} . From this point, the slope of the curve changes to:

$$\frac{(R25 + R26) R30}{R25 + R26 + R30} \div R21$$

(e) $-3.45 \geq V_o \geq -4.15$

The slope of the curve falls again as TR4 is brought into conduction.

(f) $-4.15 \geq V_o$

The slope of the curve falls to its least value as TR3 is brought into conduction.

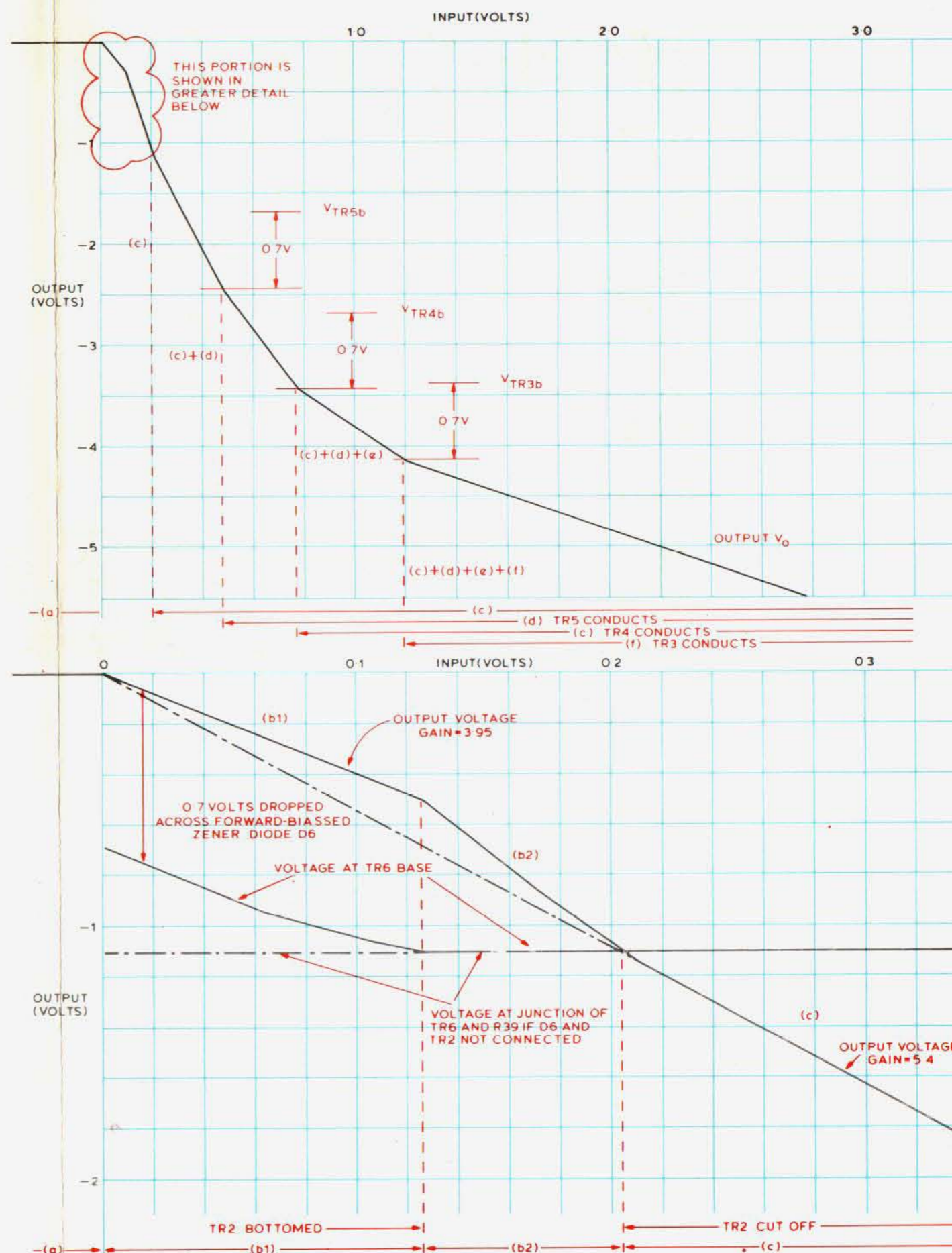

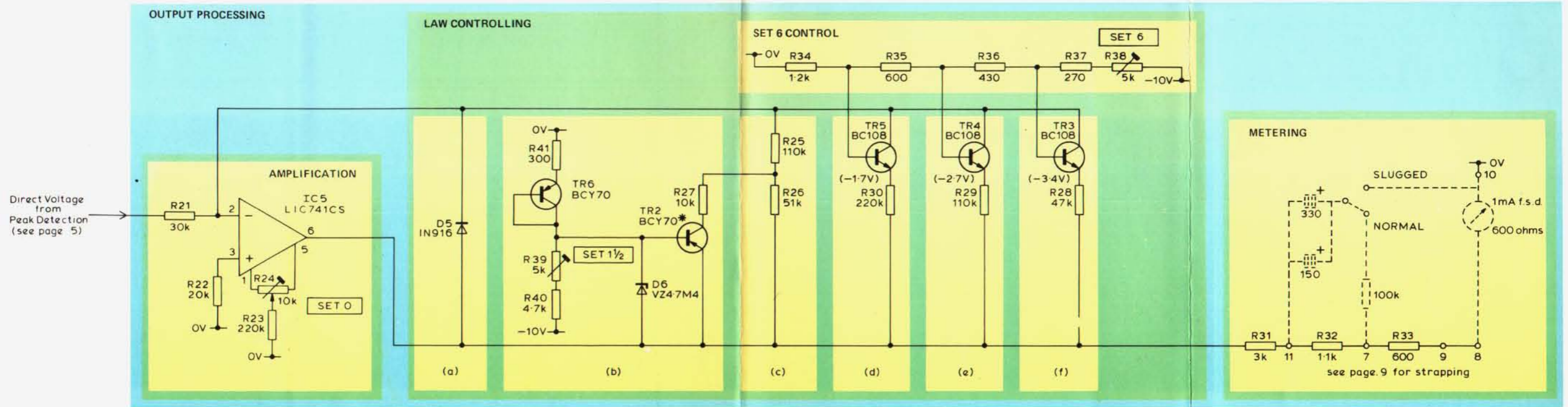

COMPONENTS FOR SLUGGED OPERATION
 330 μ F : 10% 6 V Union Carbide Type K330J6KS
 150 μ F : 10% 6 V Union Carbide Type K150J6KS
 100 k Ω : 2% Resistor Type MR25
 Single-pole changeover switch.

REF	TYPE	BASE
TR2 TR6	BCY70	 view on base
TR3 TR4 TR5	BC108	 view on top
IC5	LIC741CS	 view on top

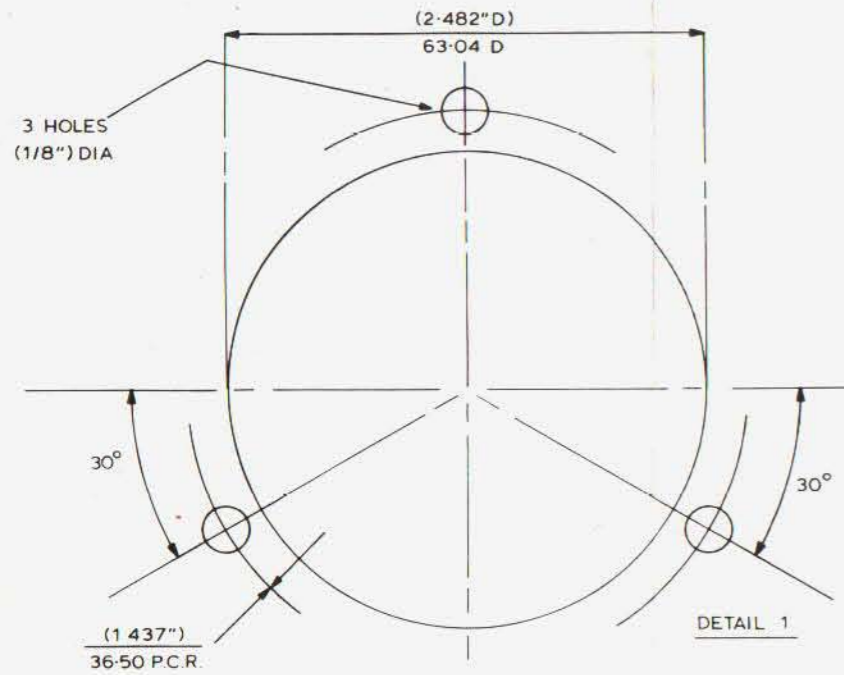

PANEL CUTOUT FOR

PPM CODE	E D METER SPEC	ERNEST TURNER INSTRUMENT STYLE
ME12/9A	1478	703
ME12/9C	1499	643
ME12/9E	1501	903

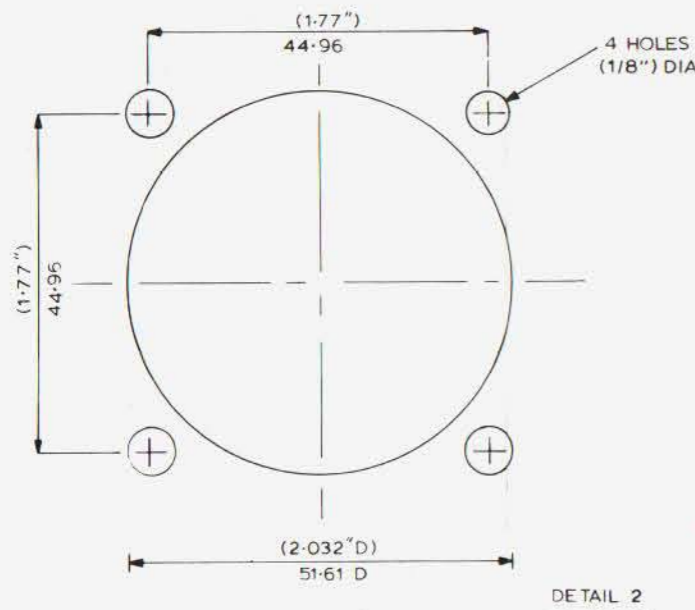

ME12/9B	1477	702
ME12/9D	1498	642
ME12/9F	1500	902

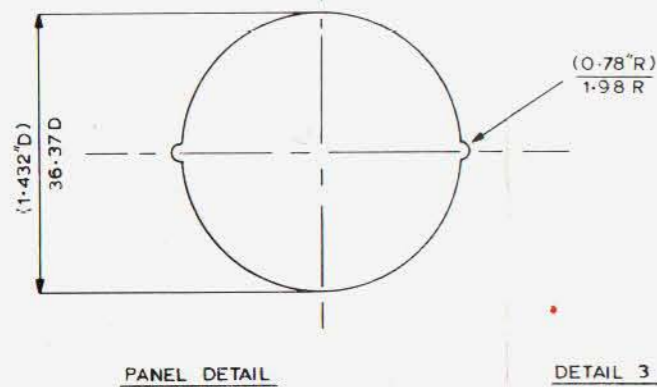

ME12/9G	1497	640
---------	------	-----

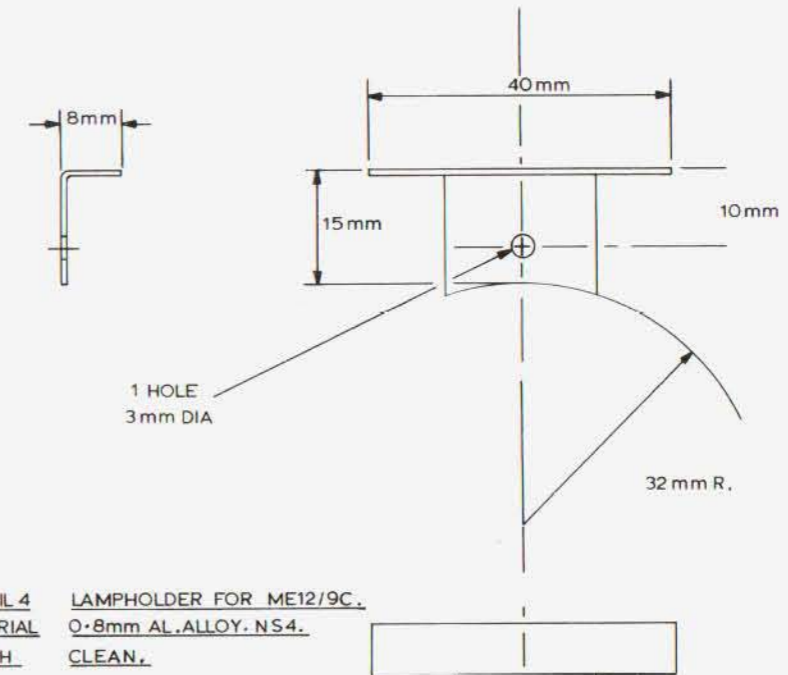

DETAIL 4 LAMPHOLDER FOR ME12/9C.
MATERIAL 0.8mm AL.ALLOY. NS4.
FINISH CLEAN.
SCALE 1:1

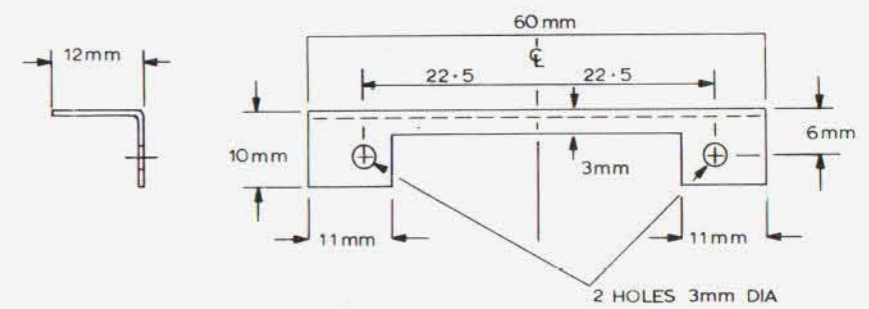

DETAIL 5 LAMPHOLDER FOR ME12/9D.
MATERIAL 0.8mm AL.ALLOY. NS4.
FINISH CLEAN.
SCALE 1:1

Metric dimensions in millimetres.
Normal tolerances:
no decimal place: ± 1mm
one decimal place: ± 0.3mm
two decimal places: ± 0.1mm
unless otherwise stated.

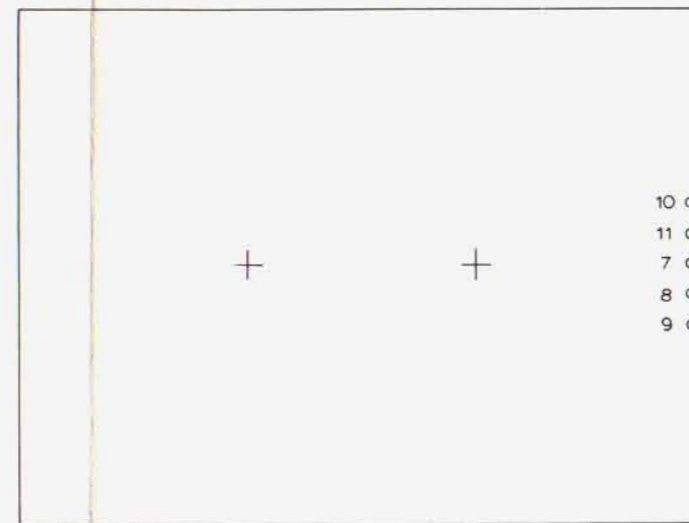
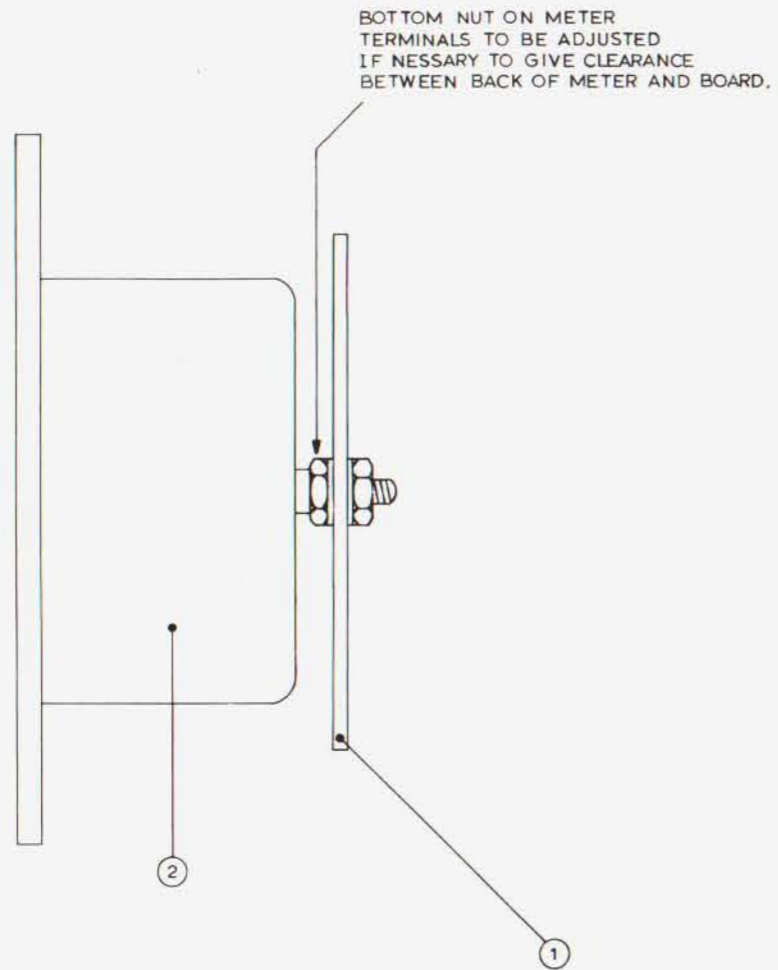

FOR STRAPPING. SEE NOTE 1

1 METER CONNECTION

- a. FOR METER ATTACHED TO P.C.B. STRAP PINS 8-9
 - b. FOR METER EXTERNAL TO P.C.B. CONNECT METER BETWEEN PIN 9&10. (+ve)
 - c. FOR METER ATTACHED TO P.C.B. AND A SLAVE METER CONNECT SLAVE BETWEEN 7&8 (+ve)
2. ASSEMBLY TO BE IN ACCORDANCE WITH EA10484 NOTE 1.

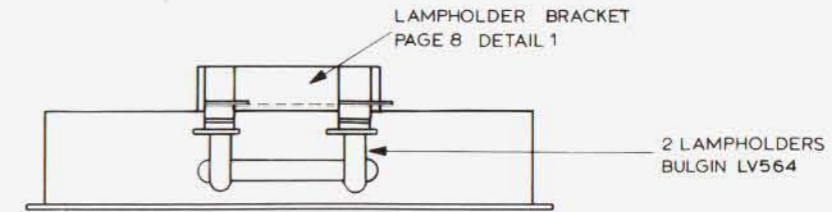
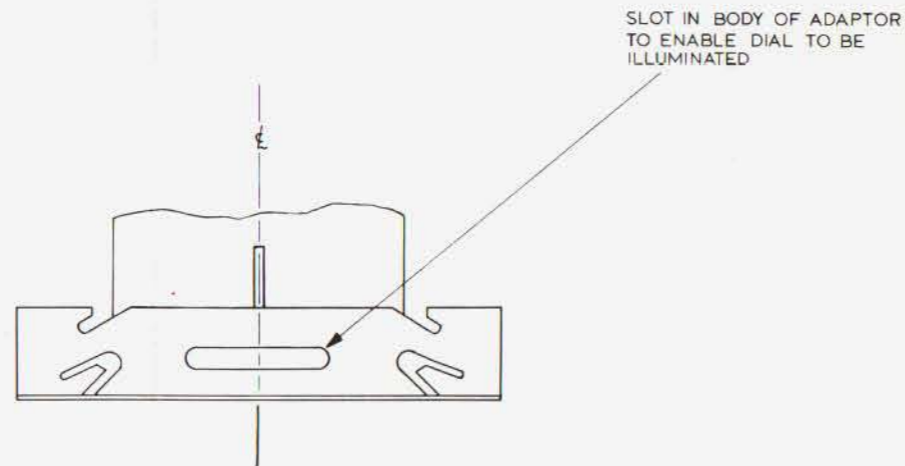

ALTERNATIVE ASSEMBLY SHOWING
METER ILLUMINATION

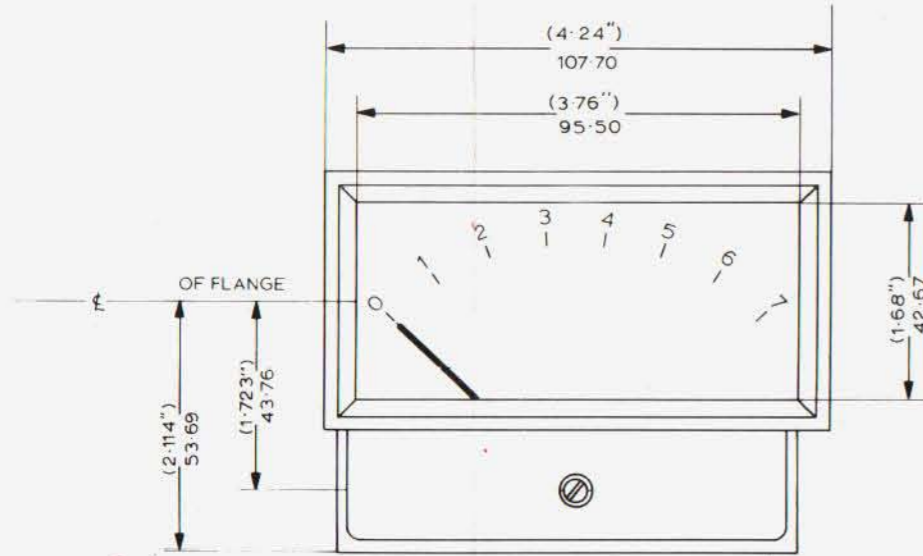

PANEL APERTURE TO BE
(4.127" x 2.031")
104.83mm x 51.59mm

MAX PANEL THICKNESS
(3/16") 4.75mm

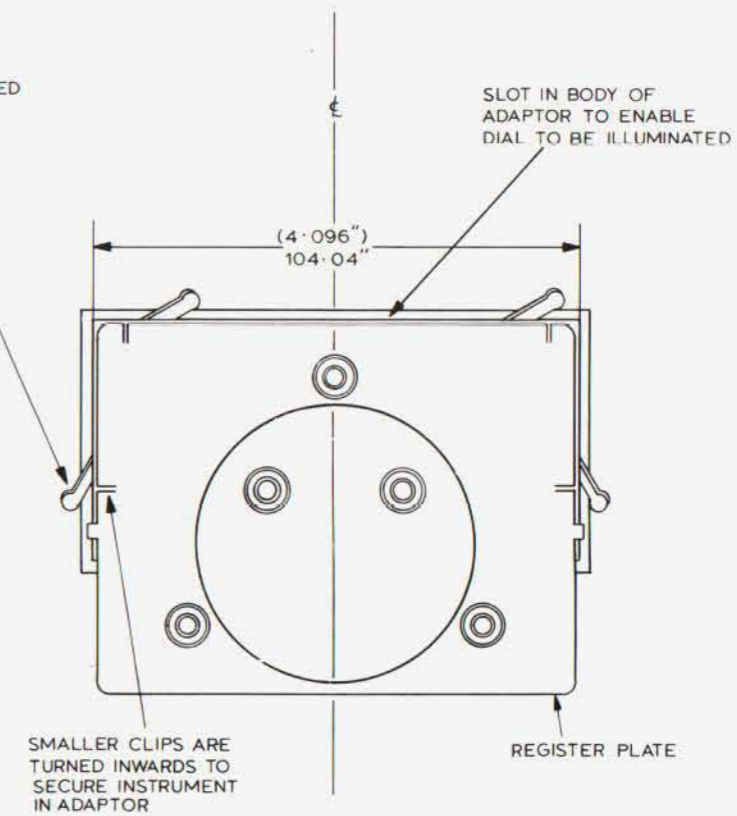
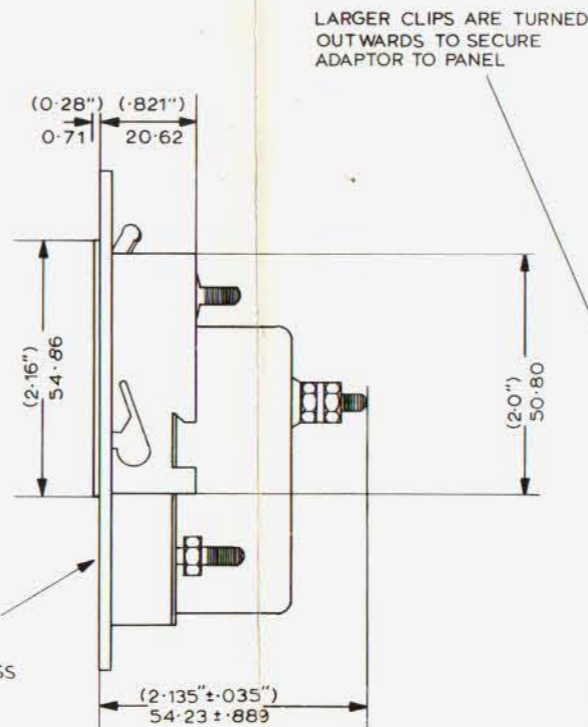

THE ADAPTOR IS MANUFACTURED
BY ENERST TURNER INSTRUMENTS LTD
FOR METER TYPES 642 AND 902

NOTE
ALL DIMENSIONS ARE FOR REFERENCE
PURPOSE ONLY

FINISH - SPRAYED MATT BLACK

FLUSH FITTING ADAPTOR FOR ME12/9D and F

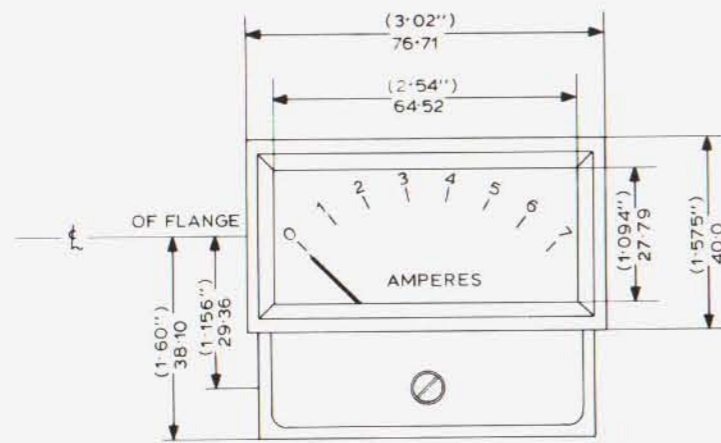
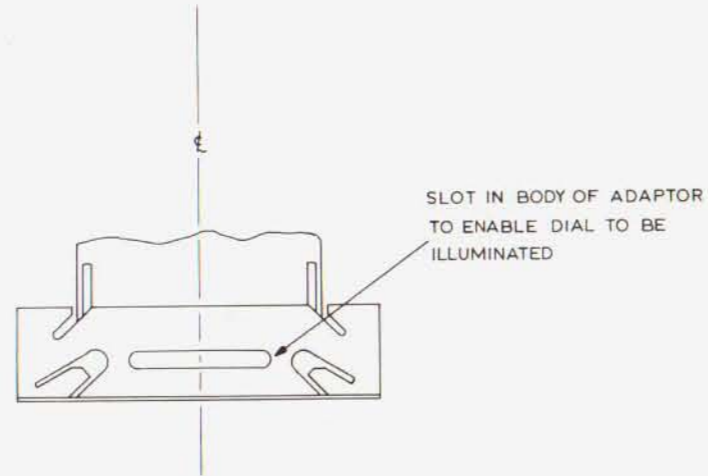

PANEL APERTURE TO BE
 (2.891" x 1.441")
 73.43mm x 36.6mm

MAX PANEL THICKNESS
 (3/16") 4.75mm

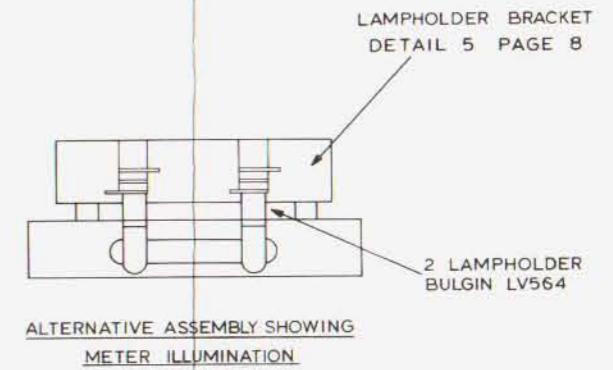
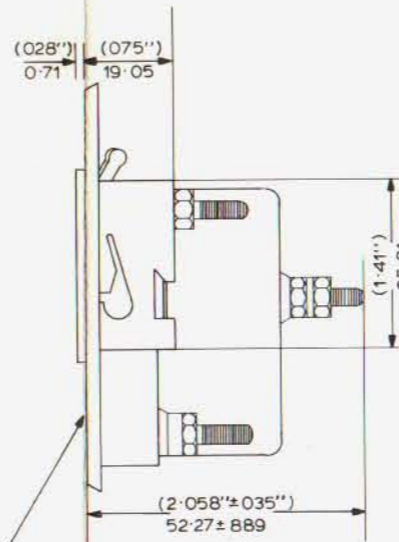

LARGER CLIPS ARE
 TURNED OUTWARDS
 TO SECURE ADAPTOR
 TO PANEL

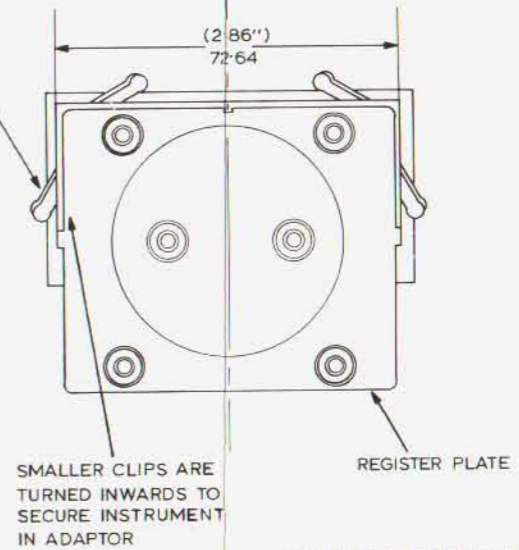

ADAPTOR IS MANUFACTURED BY
 ENERST TURNER INSTRUMENTS LTD
 FOR METER TYPES 642 AND 902

FINISH — SPRAYED MATT BLACK

NOTE
 ALL DIMENSIONS ARE FOR REFERENCE
 PURPOSE ONLY

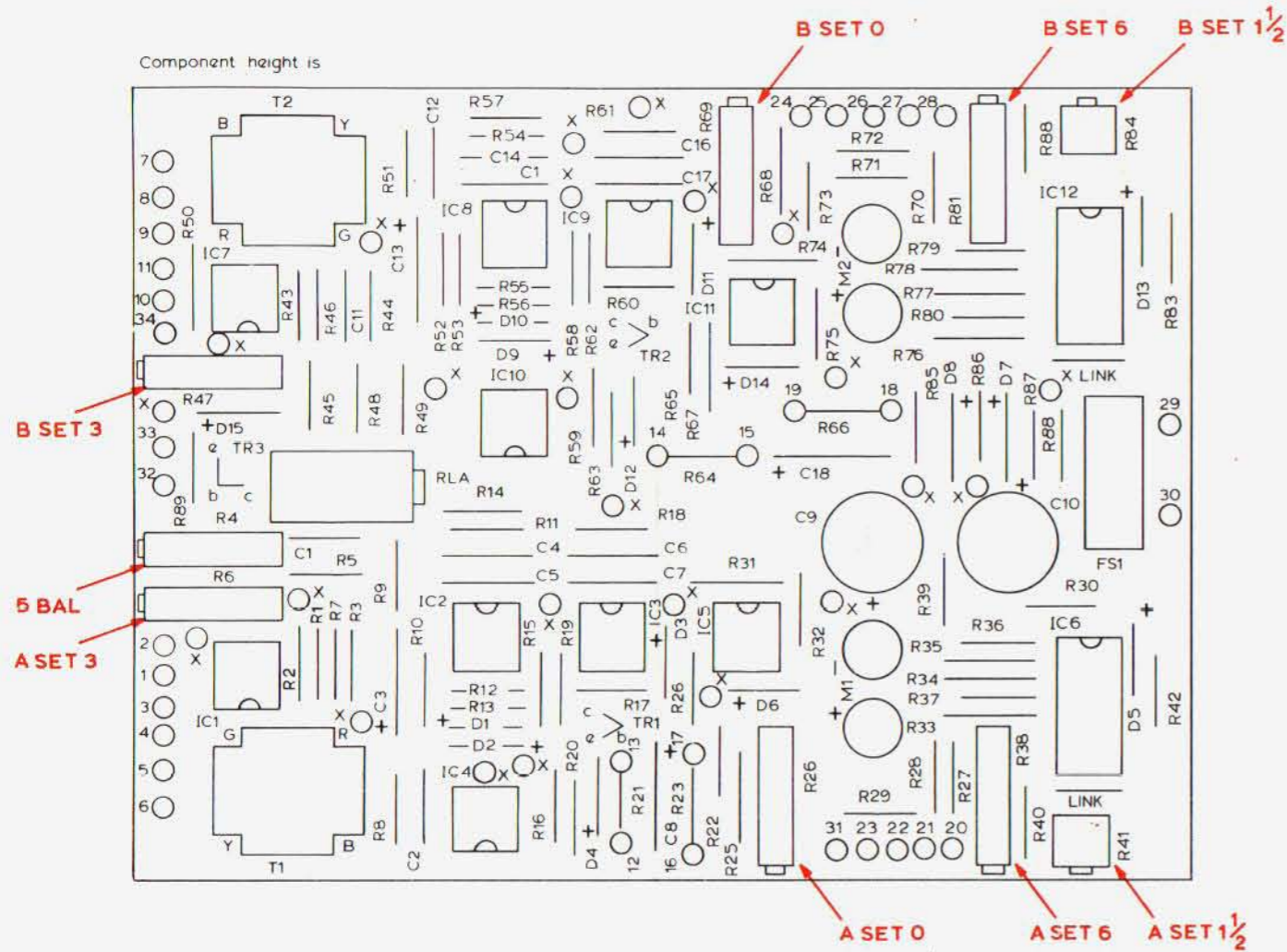

For pin assignments, see pages 12,15,16 and 17.

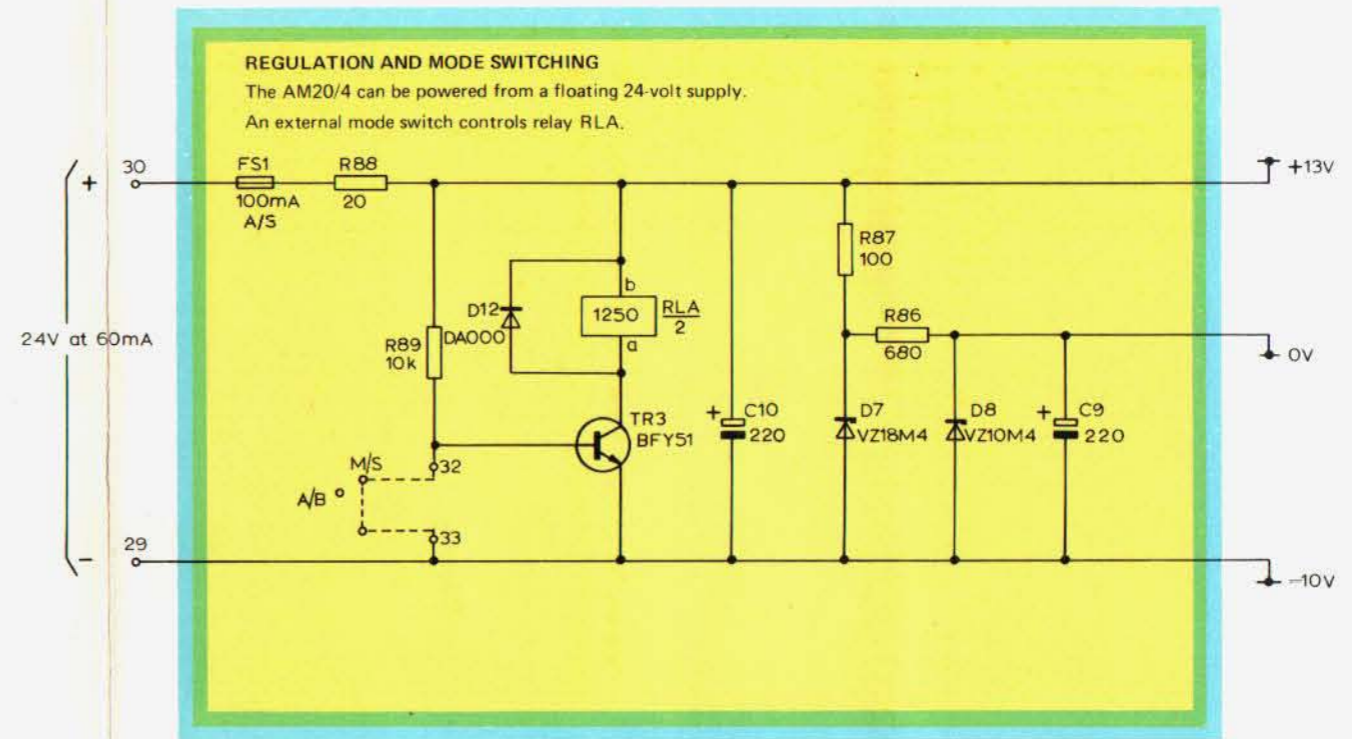

REF	TYPE	BASE
TR3	BFY51	 view on base

ALIGNMENT CHECK

Normally alignment is not required, but the following checks should be carried if the meter is changed:

- Check that, with no power applied, the mechanical zeros of the meter are correct and that the meter is in the *A/B* mode.
- Apply power and terminate each of the inputs with 600 ohms. Check that both pointers read zero. If necessary adjust R26 (*A SET 0*) and R69 (*B SET 0*).
- Apply 1-kHz tone at -4 dB to both inputs. Check that both pointers read 3. If necessary adjust R6 (*A SET 3*) and R47 (*B SET 3*).
- Apply 1-kHz tone at $+8$ dB to both inputs. Check that both pointers read 6. If necessary adjust R38 (*A SET 6*) and R81 (*B SET 6*).
- Apply 1-kHz tone at -10 dB to both inputs. Check that both pointers read $1\frac{1}{2}$. If necessary adjust R41 (*A SET $1\frac{1}{2}$*) and R84 (*B SET $1\frac{1}{2}$*).
- Switch the meter to the *M/S* mode. Feed in-phase 1-kHz tone to both inputs at -3 dB. Check that the A:M pointer reads 4 and that the B:S pointer reads 0. If necessary remove link between pins 10 and 11 to make it easier to adjust R4 (*S BAL*). Replace link between pins 10 and 11. Switch back to the *A/B* mode.
- Check that the input levels of 1-kHz tone to give the readings below are within the specified limits:

1	-12 ± 0.5 dB
2	-8 ± 0.2 dB
3	-4 ± 0.3 dB
4	0 ± 0.2 dB
5	$+4 \pm 0.3$ dB
6	$+8 \pm 0.2$ dB
7	$+12 \pm 0.5$ dB
- Check that the frequency response of both halves of the unit is:

40 Hz to 20 kHz	0 ± 0.3 dB
10 Hz	-2 ± 0.5 dB
5 Hz	-5 ± 0.8 dB
- Check that the fallback time of the pointers from a reading of 7 to a reading of 1 lies between 2.5 and 3 seconds.
- If a Peak Programme Meter Tester (e.g. TE1/25) is available, check the rise time. Set the level of the 5 kHz tone to read 6 on both pointers and measure the drop in indicated level for the following burst durations:

100 ms	0 ± 0.5 dB
10 ms	-2.5 ± 0.5 dB
5 ms	-4.0 ± 0.75 dB
1.5 ms	-9.0 ± 1.0 dB

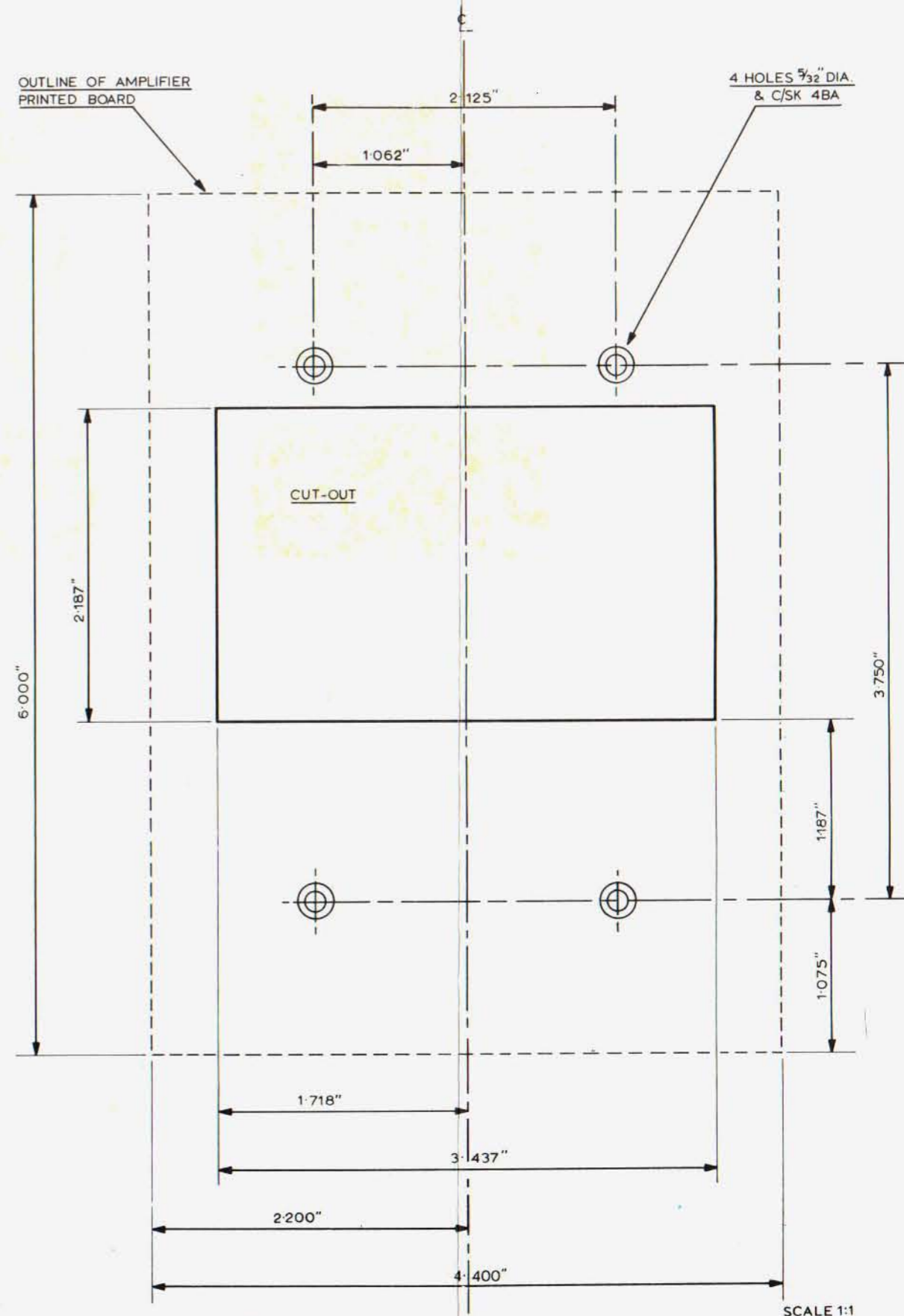

FUNCTIONAL BLOCK DIAGRAM

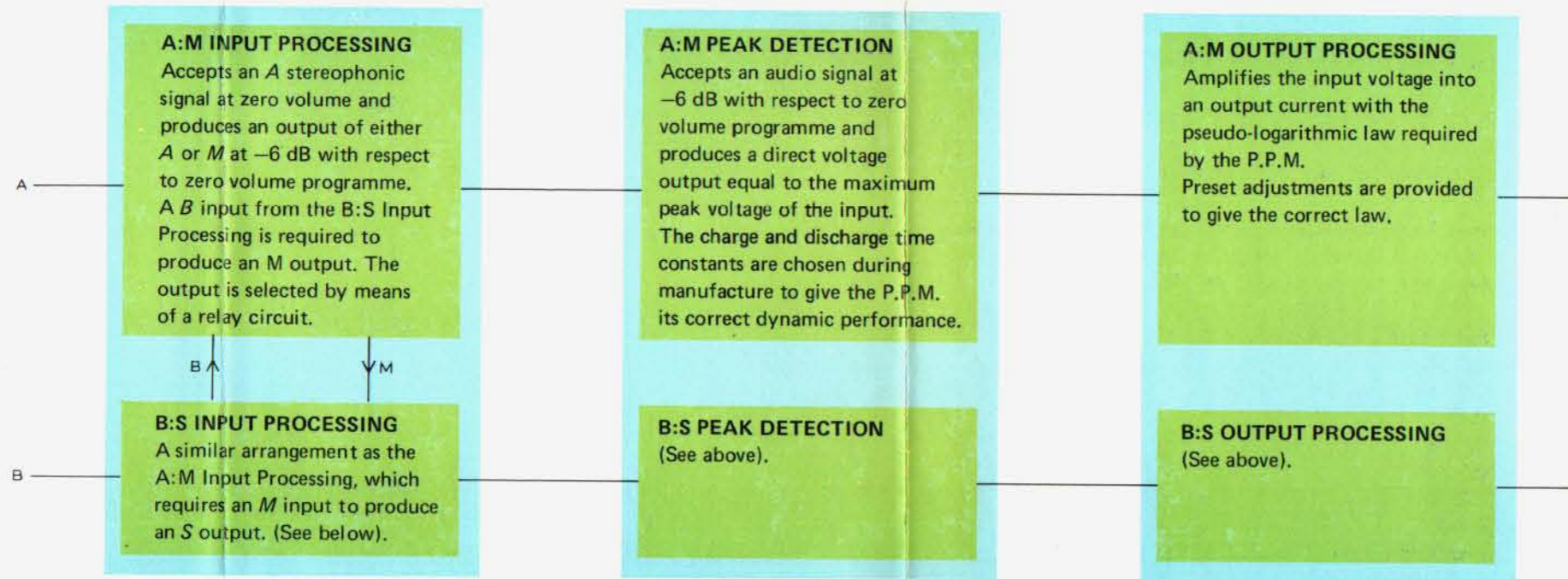

SIMPLIFIED CIRCUIT OF A/B : M/S SWITCHING

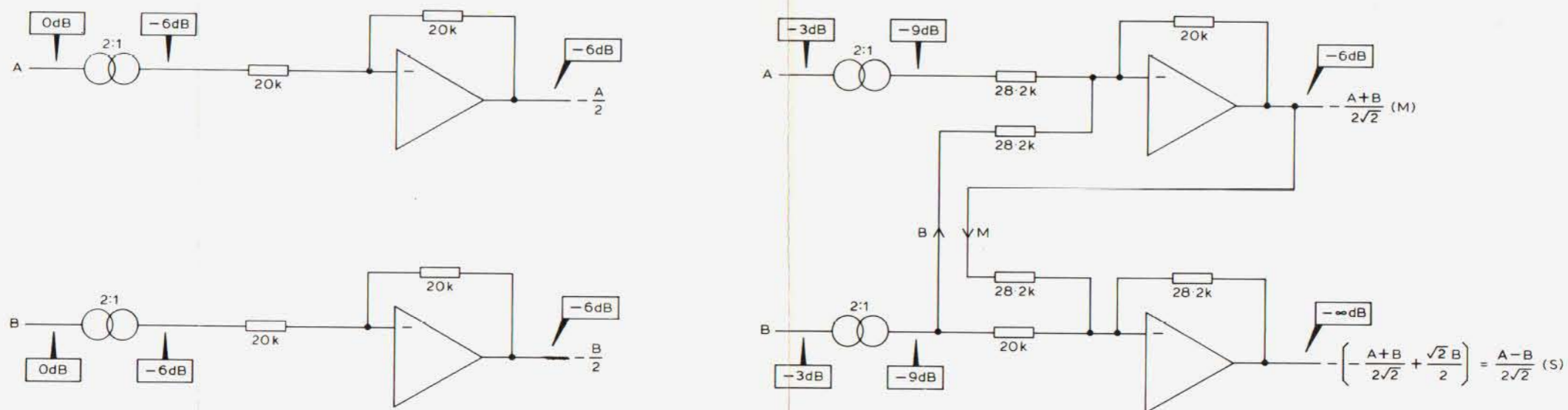

These two simplified circuits of the Input Processing shows the circuit differences between the A/B and the M/S modes. They also show the levels involved to obtain A, B and M outputs of -6 dB, assuming that the A and B inputs are the same signal. The M output is known as $A + B - 3$ dB. This 3 dB is implied by the $\sqrt{2}$.

In the full circuit, shown on page 15, some of the resistor values are greater than those shown here. This is because some gain is required from the amplifiers to compensate for the loss in Treble Lifting and the loss in excess of 6 dB in the input transformers.

AM20/4 INPUT PROCESSING CIRCUIT

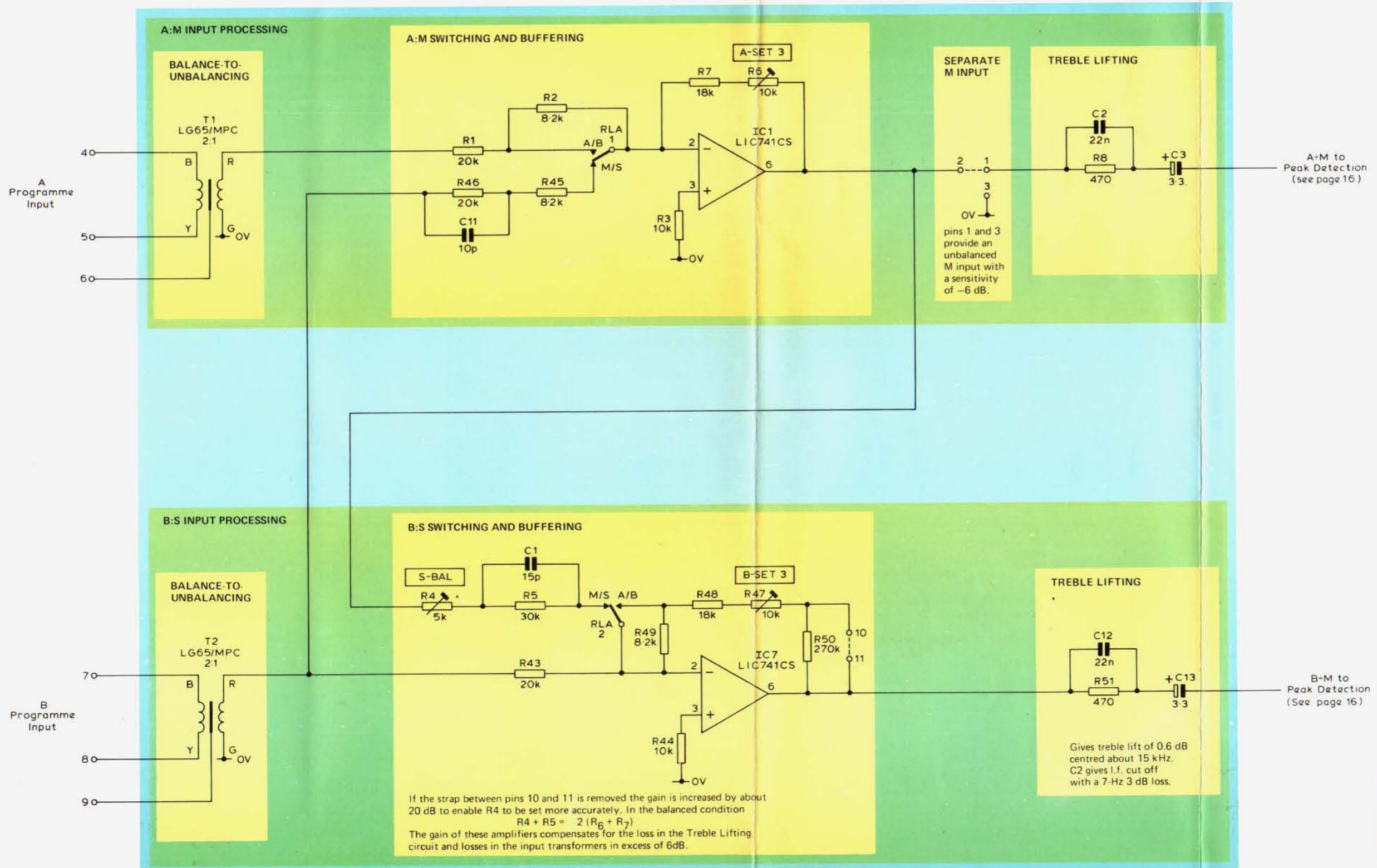

REF	TYPE	BASE
IC1 IC7	LIC741CS	<p>view on top</p>

A:M PEAK DETECTION

HALF-WAVE RECTIFICATION

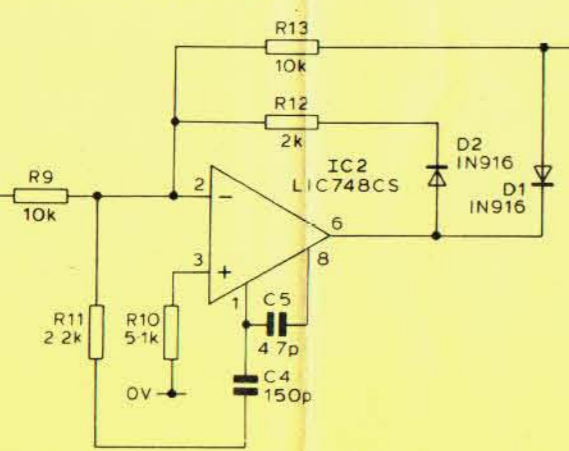

SUMMING AND COMPARISON

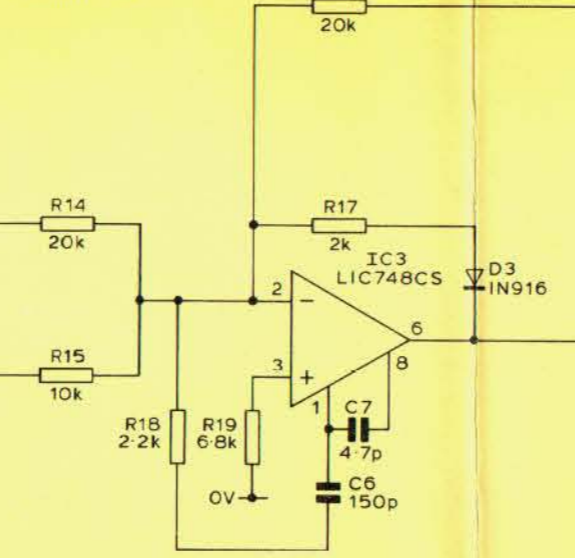

VOLTAGE FOLLOWER

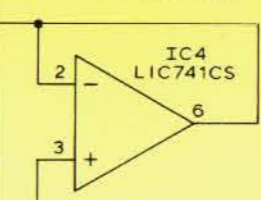

EMITTER FOLLOWER

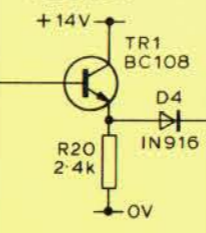

PEAK VOLTAGE STORE

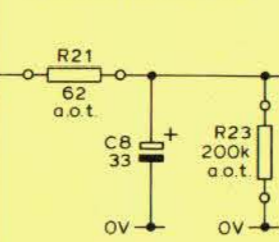

B:S PEAK DETECTION

HALF-WAVE RECTIFICATION

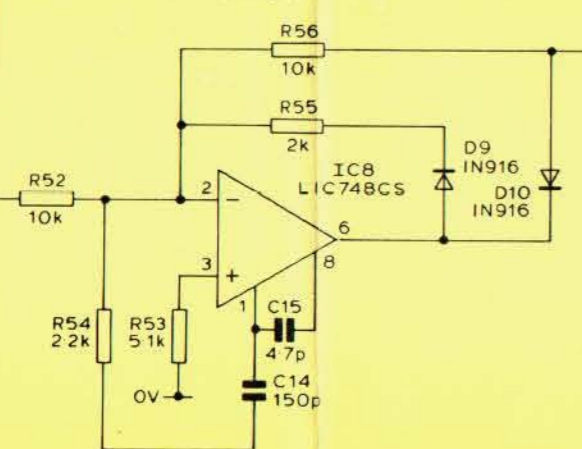

SUMMING AND COMPARISON

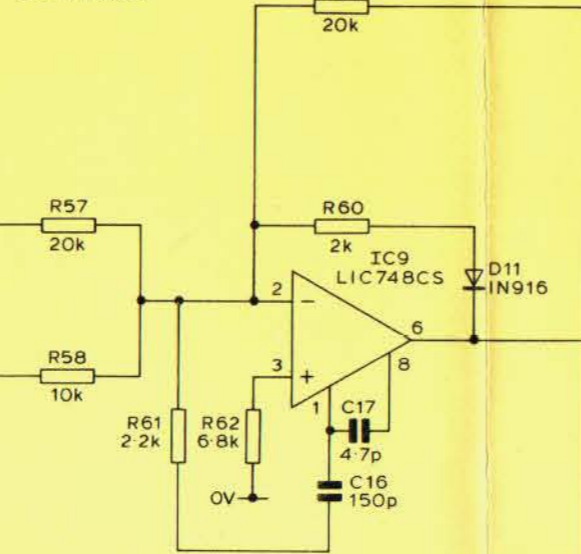

VOLTAGE FOLLOWER

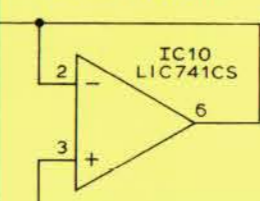

EMITTER FOLLOWER

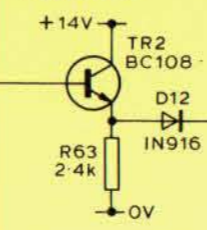

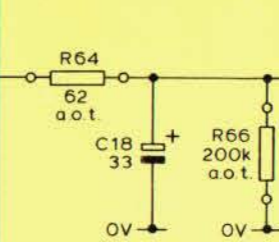

PEAK VOLTAGE STORE

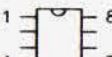

A:M from Input Processing (see page 15)

B:S from Input Processing (see page 15)

REF	TYPE	BASE
TR1 TR2	BC108	 view on base
IC2 IC3 IC8 IC9	LIC748CS	 1 8 4 5
IC4 IC10	LIC741CS	 view on top

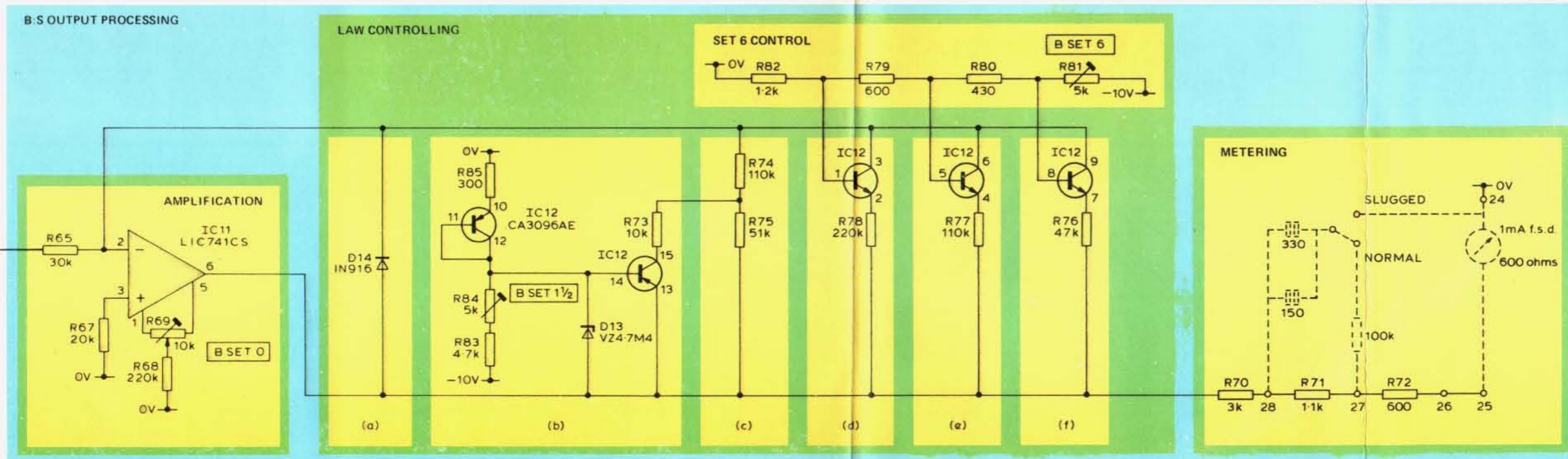
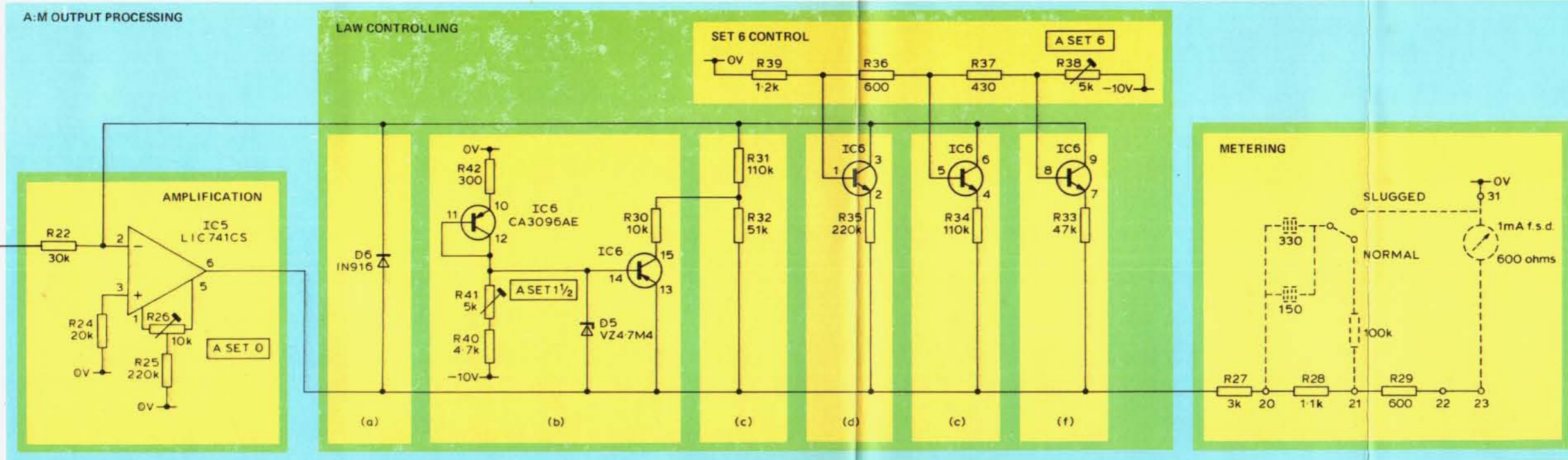

REF	TYPE	BASE
IC5 IC11	LIC741CS	<p>view on base</p>
IC6 IC12	CA3096AE	<p>view on top</p>