

EQxx07 AND YQxx07

Active and reactive power meters and Power factor meters with exchangeable scales

EQ0207 AND EQ2207

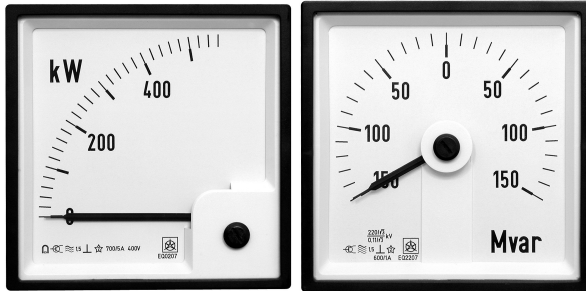

Picture 1: Wattmeters and varmeters EQ0207, EQ2207

YQ0207 AND YQ2207

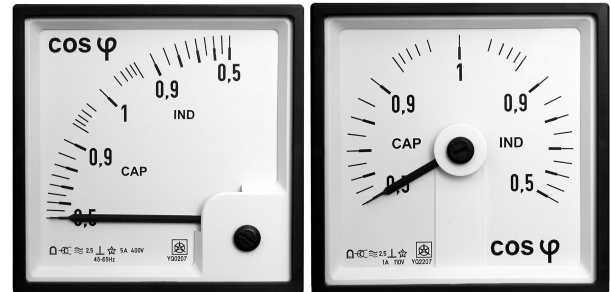

Picture 2: Wattmeters and varmeters YQ0207, YQ2207

FEATURES:

- Mounting in compliance with DIN 43700
- Measurement of:
 - Power factor (YQ) or
 - Active, reactive and apparent power (EQ)
- Single or three phase, 3 or 4 wire, balanced or unbalanced connection
- Power supply from measuring power system or separate
- Low self-consumption
- Wide frequency range of operation
- Exchangeable scale
- Protective cover for terminals (optional)

CONSTRUCTION

The instrument operates on fast sampling method of input quantities (current and voltage) on all three phases. From the input data microprocessor calculates active, apparent power (EQ) or power factor (YQ). Meter comprises current transformers, voltage dividers, microcontroller and power supply unit. Measuring system with moving coil is connected to the microcontroller. The instrument scale is calibrated on W, var or $\cos\phi$, considering ratios of current and voltage transformers. Long term stability is achieved by storing setup and calibration constants into microcontroller. Easy and fast scale exchange is possible because of the meter's construction.

TECHNICAL DATA

AMBIENT CONDITIONS

- JVF (DIN 40 040)**
- Climatic conditions: Standards EN 60051-1: 1995/01
EN 60051-2: 1984
EN 60051-9: 1988
 - Temperature:
 - Reference range of operation +18 ... +28°C
 - Nominal range of operation -25 ... +55°C
 - Storing -40 ... +70°C
 - Humidity up to 80% (without condensing)

ACCURACY:

- accuracy class 1,5

Ship version

Special "ship version" are delivered for building into ships. These are mechanically resistive instruments which correspond to the rules of construction of sea-going ships. The instrument case is marked by an anchor: and a capital letter L at the end of the type designation (EQ0107L / YQ0107L).

VOLTAGE INPUT:

- Nominal voltage (Un(L-N) / Un(L-L) AC)
57.7V / 100V, 63.5V / 110V, 230V / 400V AC
- Consumption <0.1 VA per phase
- Overload capacity 1.5 x Un continuously, 2 x Un for 10 s

CURRENT INPUT

- Nominal current (In) -1 A or -5 A
- Consumption <0.1 VA per phase
- Overload capacity 3 x In continuously, 25 x In for 3 s, 50 x In for 1 s

FREQUENCY

- Nominal frequency (fn) 50/60Hz
- Measuring range 45Hz to 65Hz

HOUSING:

- Material of housing: PC/ABS
non-flammable, according to UL 94 V-0
- Enclosure protection: case IP 52
terminal contacts IP 00
(IP 20 for connection terminals)
according to EN 60529: 1989
- Operating position Vertical
- Weight: below 500g

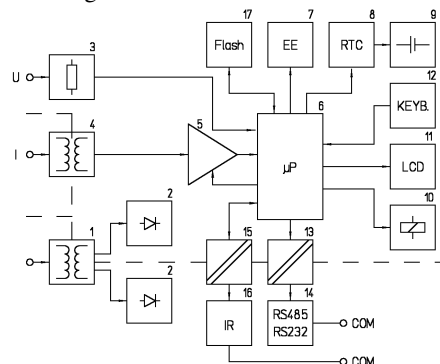

Picture 3: Block diagram

REGULATIONS:

- Protection: Protection class II
Aux. supply AC 600 V, installation category III
Aux. supply AC / DC 300 V, installation category III
Pollution degree 2
- Test voltage: 3.7 kV rms
according to **EN 61010-1: 1990**

SCALE

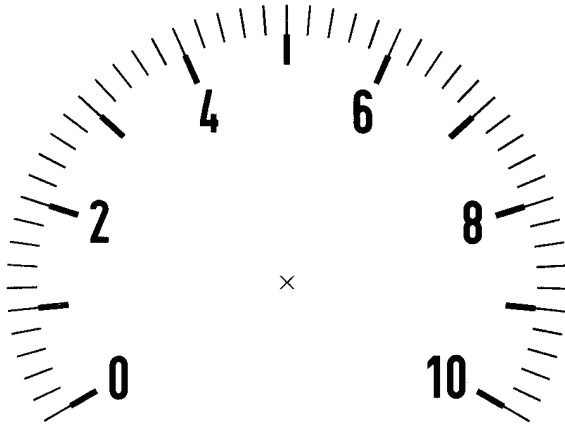

Picture 4: Drawing of scale: EQ2207)

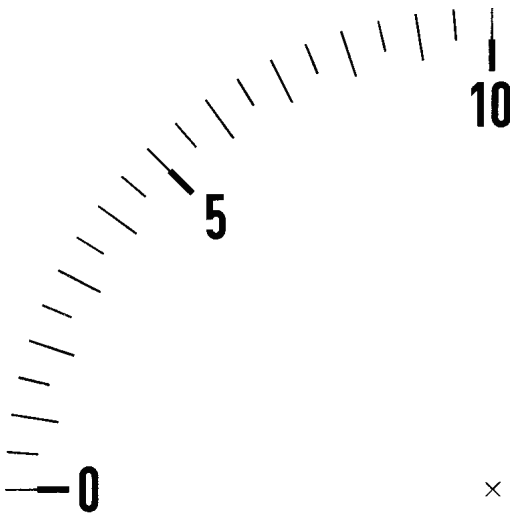

Picture 5: Drawing of scale: EQ0207

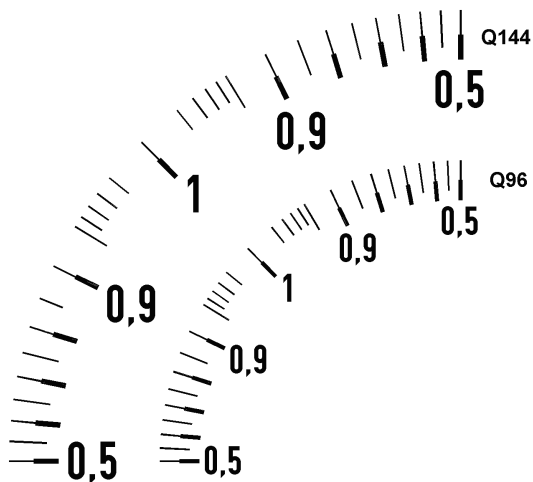

Picture 6: Drawing of scale: YQ0107, YQ0207

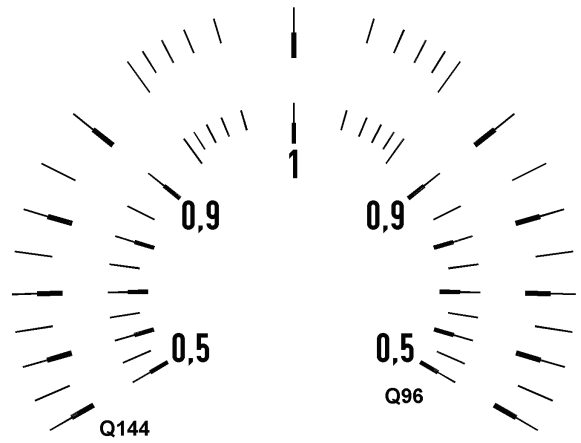

Picture 7: Drawing of scale: YQ2107, YQ2207

EXCHANGING OF SCALES

Press the cover, on top of the instrument, in the direction of the arrow and extract the scale with a suitable tool. After exchanging the scale, carefully close the opening with the cover.

During the replacement procedure the instrument must be disconnected.

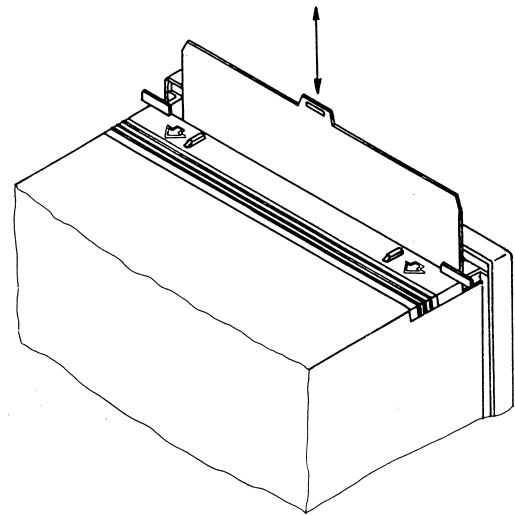

Picture 8a: Exchanging of scales

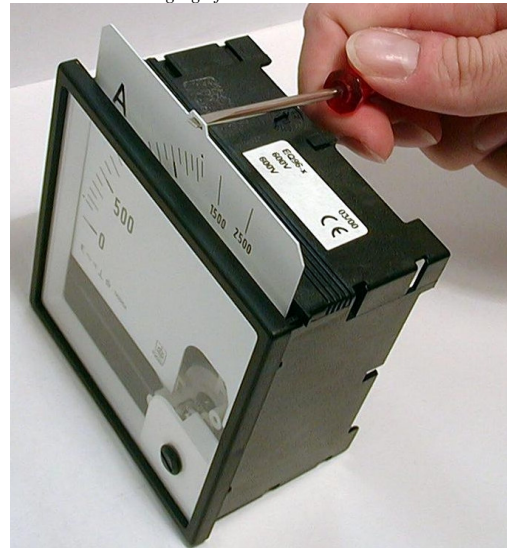

Picture 8b: Exchanging of scales

END SCALE VALUE (EQ):

The end scale value is determined as follows:

The power to be measured by the instrument can be calculated by using one of the formula below:

	<u>active</u>	<u>reactive</u>
Power in single-phase system	$U I \cos\phi$	$U I \sin\phi$
Power in three-phase 3-wire system	$\sqrt{3}U I \cos\phi$	$\sqrt{3}U I \sin\phi$
Power in three-phase 4-wire system	$3 U I \cos\phi$	$3 U I \sin\phi$

U in equations the phase voltage in single-phase system, line voltage in three-phase 3-wire system, and phase voltage in three-phase 4-wire systems.

According to the calculated value, one of the following standard end scale values and their decade are chosen:

1-1, 2-1, 5-2-2, 5-3-4-5-6-7, 5-8

Accordingly, it has been considered that the scale factor, i.e. the relation between the end scale value and the apparent power ($\cos\phi$ or $\sin\phi$ is 1) must be within limits of 0,6 ... 1,2.

CONNECTION DIAGRAMS

Power metres' and power factor's voltage inputs can be connected directly to the low-voltage network, or to the high-voltage network via high-voltage transformer.

Power metres' and power factor's current inputs can be connected to the low-voltage network via current transformer or to the high-voltage network via high-voltage current transformer.

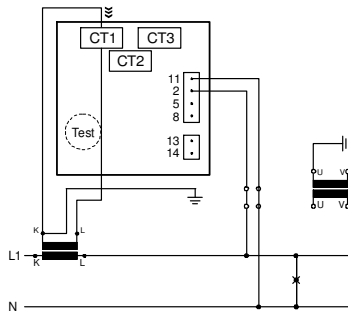

Picture 9: Single phase system (1b)

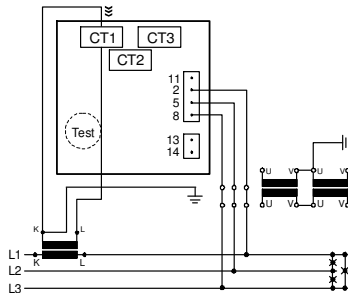

Picture 10: Three phase system (three wire balanced - 3b)

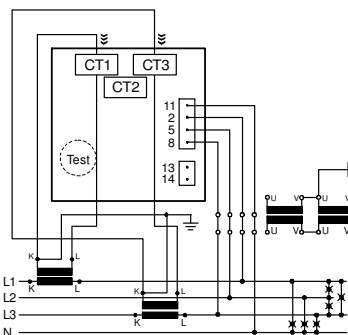

Picture 11 : Three phase system (three wire unbalanced - 3u)

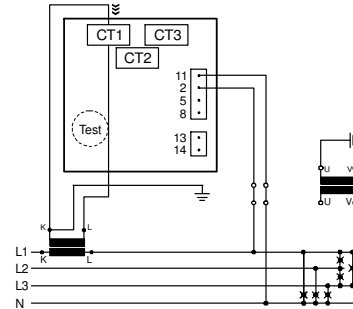

Picture 12: Three phase system (four wire balanced - 4b)

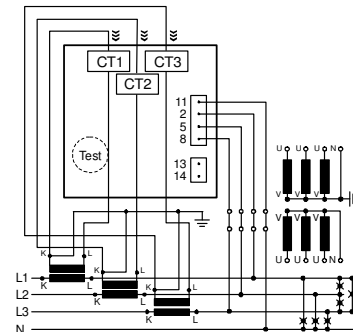

Picture 13: Three phase system (four wire unbalanced - 4u)

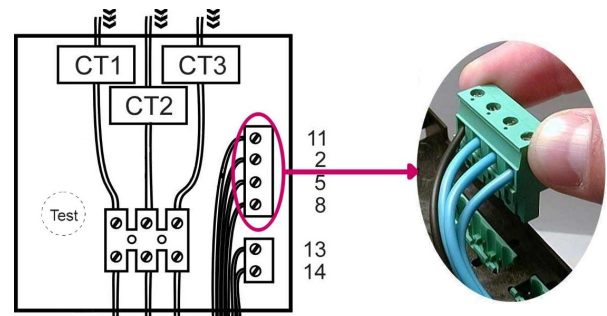

Picture 14: Connections for full equipped device, position of battery and picture of connectors

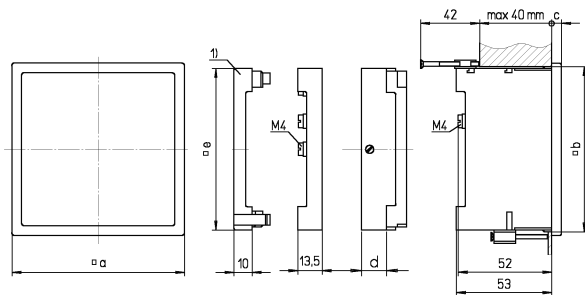

Picture 15: Dimensional drawing EQXX07 and YQXX07 (all dimensions are in mm)

Type		EQ0107	EQ2107	EQ0207	EQ2207
		YQ0107	YQ2107	YQ0207	YQ2207
Bezel height (mm)	□ a	144	144	96	96
Panel cut-out (mm)	□ b	138 ^{+1,0}	138 ⁺¹	92 ^{+0,8}	92 ^{+0,8}
Bezel height (mm)	c	144	144	96	96
Protect cover (mm)	□ e	90	90	90	90
Scales length (mm)		135	135	95	95
Base (mm)	□ d	54	54	28	54

Weight approx. (kg) 0,9 1,1 0,5 0,7

Table 1: Dimensions and weight

SPECIFICATION AND ORDERING INFORMATION

Instrument:

For ordering it is necessary to specify:

- Type of instrument.
- Type of system
- Rated current or current ratio.
- Rated voltage or voltage ratio.
- End scale value acc. to technical data.
- Auxiliary power supply.

When ordering "ship version" it is necessary to add a capital letter L at the end of the type designation.

Ship version is available only for YQ0207L and EQ0207L.

When ordering scales the same data as in case of ordering the instrument must be state.

ORDERING EXAMPLE:

Instrument for measuring of power factor in single phase system, voltage 230 V, 5 A, measuring range 0.5 cap. ...1... 0.5 ind.

YQ0207 – 1b, 230 V, 5 A, 0.5 cap. ...1... 0.5 ind

XQ0207; a; bA; cV; d; (e); f; g

Description		Code		
Type of instrument:				
X	Instrument specifications	Power meter E		
		Factor meter Y		
a	Inputs:	Type of system		
		Single phase system (1b)	1B	
		Three phase system (three wire balanced - 3b)	3B	
		Three phase system (three wire unbalanced - 3u)	3U	
		Three phase system (four wire balanced - 4b)	4B	
		Three phase system (four wire unbalanced - 4u)	4U	
		Nominal input voltage		
b	Measuring range	1 A	1	
		5 A	5	
c	Measuring range phase to neutral	Nominal input current		
		57.74 V _{L-N}	57.74	
		63.5 V _{L-N}	63.5	
d	End scale value:	230 V _{L-N}	230	
		For EQxxxx	any ≤ calculated max value ¹⁾	x W
e	Auxiliary power supply:	For YQxxxx	0,5 cap. ... 1 ... 0,5 ind.	1
			0,8 cap. ... 1 ... 0,3 ind.	2
		Type of power meter		
f	Type of power supply	EQxxxx only	Wat, Var or VA meter	W / Q / S
g	Value of power supply voltage (only for AC power supply)	No external supply		-
		AC auxiliary power supply		A
		57.74 V _{L-N}		E 57.74
		100 V _{L-N}		E 100
		110 V _{L-N}		E 110
		230 V _{L-N}		E 230
		400 V _{L-N}		E 400
		500 V _{L-N}		E 500

Table 2: Ordering information

¹⁾ See End Scale Value chapter on Page 3.

SPECIAL VERSIONS:

- Special marking on scale or blank scale
- Empty scale
- Ship version (YQ0207L and EQ0207L only)
- A protective cover against live parts
- Zero on any point of the scale



Iskra MIS, d.d.
Ljubljanska c. 24a, SI-4000 Kranj, Slovenia
Tel.: +386 4 237 21 12, Fax: +386 4 237 21 29
E-mail: info@iskra-mis.si, www.iskra-mis.si

