







635 & 636 Series AC Hour Meters (ETI's)

-  24, 115, 220 VAC Operating voltage
-  Continuous duty, rugged design
-  Tamper resistant
-  Permanently lubricated
-  6 Figure display: 99999.9
-  Round or Square bezel mounting
-  UL/cUL Approved



Square Style "Y" Bezel
Model #635 Non-resettable



Round Style "X" Bezel
Model #636 Resettable

Cramer AC Hour Meters can be found in these applications and more:



CNC Machine Tools



Waste Water Treatment



Construction Equipment



Control Panels

635 & 636 Series AC Hour Meters (ETI's)

Applications

CNC Machine Tools



Construction Equipment



Waste Water Treatment

Control Panels



Dimensions



Model #635 Non-resettable Round & Square Bezel



Model #636 Resettable Round & Square Bezel



Most Popular Configurations

| Model # 635 | | |
|-------------|------------|-------------------|
| Part # | Bezel type | Time Registration |
| 10055 | Round | HRS/TEN 115/60 |
| 10063 | Square | HRS/TEN 115/60 |
| 10069 | Round | MIN/TEN 115/60 |
| 10071 | Round | HRS/TEN 115/60 |
| 10186 | Square | HRS/TEN 115/60 |
| 30850 | Square | HRS/TEN 115/60 |
| Model # 636 | | |
| 10072 | Round | SEC/TEN 115/60 |
| 10074 | Round | MIN/TEN 115/60 |
| 10075 | Round | HRS/TEN 115/60 |
| 10080 | Square | SEC/TEN 115/60 |
| 10083 | Square | HRS/TEN 115/60 |
| 10086 | Square | MIN/TEN 115/60 |

Additional configurations available.

Style "X" & "G" Bezel

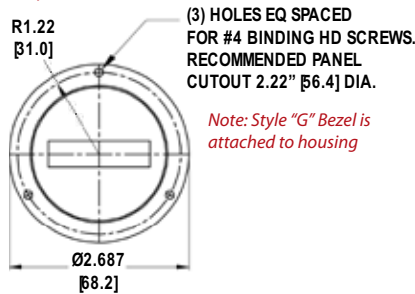

Bezel Styles

Style "Y" & "K" Bezel

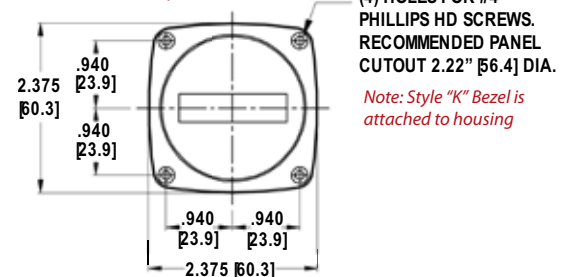

Style "E" Bezel

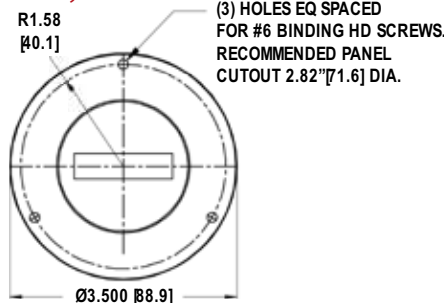

Style "S" Bezel

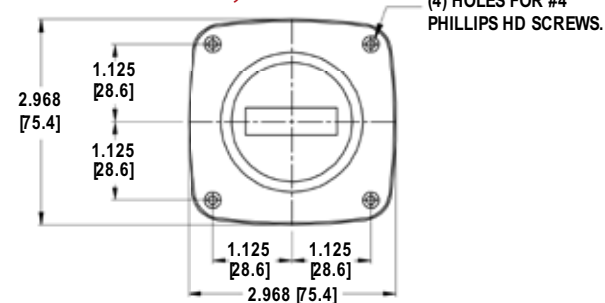

Specifications

| Model | 635 | 636 |
|-----------------------------|--|---------------------------|
| Display | 6 Figure; 99999.9 | |
| Time Registration | Minutes or Hours (Seconds Special Order) | Seconds, Minutes or Hours |
| Resettable | Not available | Push button |
| Motor Specification | 24, 115, 220 VAC; 50 or 60hz | |
| Power | 2.7 Watts | |
| Operating Temperature Range | -4°F to 131°F (-20°C to 55°C) | |
| Electrical Connection | 6" (15 mm) Leads, 22 gauge wire | |
| Front Panel Mounting | 3 hole Round, 4 hole Square | |
| Agency Approval | UL/cUL | |

Options

- Bezel Style: E, X, S, or Y
- Resettable to "zero"
- Non-resettable: Recommended when tamper proofing is required to record total "on time"

www.mhrhodes.com



M.H. Rhodes Cramer Company
 105 Nutmeg Road South • South Windsor, CT 06074 USA
 Toll Free: 877.684.6464 • PH: 860.291.8402 • FX: 860.610.0897