



'SERIES 3' AMPLIFIERS

INSTALLATION

1. GENERAL

This instruction is applicable to all 'Series 3' amplifiers: MA 15, MA 25, STA 15 and STA 25.

2. MAINS INPUT VOLTAGE SELECTION

All amplifiers are designed to operate from A.C. Mains of 100 - 140 v and 200 - 250 v., 50 - 60 c/s.

Operation in one or other of the voltage ranges is obtained by the series or parallel connection of two basic windings of 110 V, together with a supplementary winding to extend the winding by 15 V or 30 V. Thus, with the two 110 V windings in parallel the input voltage range is 0 - 110 V - 125 V - 140 V, and in the series connection 0 - 220 V - 235 V - 250 V. These are design centre values and the equipment is designed to operate on higher voltages than the design centre without overheating, and lower voltages without apparent loss of efficiency. It is recommended however, that the input voltage is within +5% or -10% of the design centre values shown on the voltage selector dial. For example, an input supply of 240 V nominal can be used on the 235 V or 250 V position, or an input supply of 115 V nominal on the 110 V or 125 V position.

The change from one supply voltage range to the other is effected by a change in the connections on the transformer tag jacket, and the change within a range, by the voltage selector on the equipment. Range adjustments should be made in accordance with Fig. 1. A soldering iron is necessary for this operation which will normally be carried out by the dealer, if required. All equipments leave the factory wired for operation on the 200-250 V range unless specified otherwise.

Fig. 1.

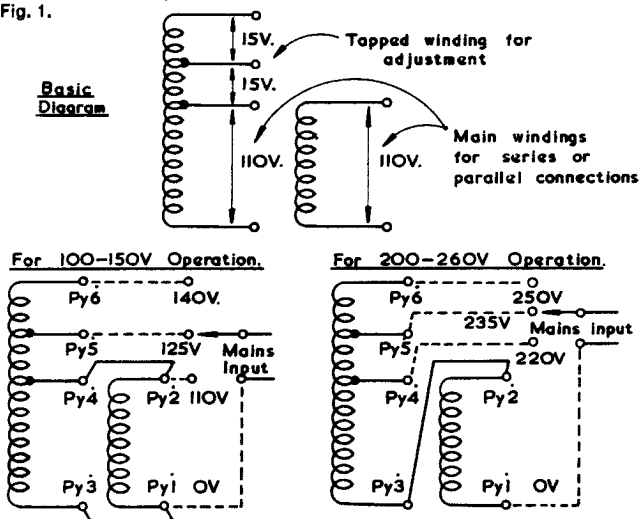

3. VENTILATION

It is essential that adequate ventilation is provided. If amplifiers are fitted in enclosures, an easy air passage should be arranged to ensure convection.

4. MAGNETIC RADIATION

Although the amplifiers are fitted with mains transformers which have low magnetic radiation, it is advisable to take full advantage of the extremely high signal to noise ratio of the amplifiers by locating them as far as possible from magnetic pick-ups, tape heads etc. Should any trouble be encountered in this respect, a slight re-orientation of the power amplifier(s) can sometimes result in a considerable improvement.

5. INPUT CONNECTIONS

The signal input connection(s) to the power amplifier should be made with a single screened cable terminated by a standard phono plug to the input socket mounted on the valve chassis.

6. LOUDSPEAKER CONNECTIONS

Use twin cable, not less than 14/.0076" but preferably 23/.0076", from each loudspeaker, and connect to the terminals provided, observing the polarity in the case of a stereo system.

7. OUTPUT IMPEDANCE SELECTION

All the amplifiers have an output selector switch with a choice of 4, 8 and 16 ohms impedance, and this should be adjusted to correspond with the nominal loudspeaker impedance.

8. EXTERNAL SUPPLY AND MAINS SWITCHING CONNECTIONS

8:1 H.T. and L.T. Supplies

External power supply connections are made via an international octal valve holder and plug connector. The supplies available are:

- a High tension of nominal 300-400 V D.C. at 10 mA rating,
- b Low tension of nominal 6.3V A.C. at 2A rating. These supplies are intended for energising a pre-amplifier control unit.

8:2 A.C. Mains and Switching

Connections to the octal socket are arranged to enable the mains supply to the power amplifier to be switched from a remote or central position, usually in the pre-amplifier.

The basic arrangement is shown in Fig. 2.

Fig. 3 shows the connections to the control unit SC2 and Fig. 4 the connections to the SC22. In the SC2, mains connections for ancillary equipment can be taken from the power amplifier (through a distribution unit if desired). Outlet sockets are provided on the SC22 for this purpose.

A connecting cable is available already wired to the plug and socket for connecting the power amplifier to a control unit SC2 or SC22. These connection cable assemblies are provided with the control unit, and the amplifier only is supplied with a free plug for connection to any equipment.

9. MAINTENANCE

9:1 Bias adjustment

MA25 and STA25 amplifiers obtain bias for the output valves from a power supply provided specially for this purpose. It is adjustable by the slotted spindle potentiometers behind the anodised aluminium panel at the rear of the chassis. This will rarely need adjustment once set but a check occasionally will indicate the wear of the output valves. The potentiometers should be adjusted for a reading of 2 volts from the test point to the chassis.

Fig. 2. BASIC CONNECTIONS OF EXTERNAL POWER SOCKET

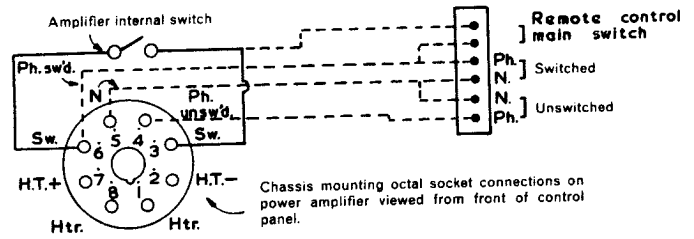

Fig. 3. EXTERNAL SUPPLY CONNECTION ARRANGEMENTS FOR SC2 CONTROL UNIT

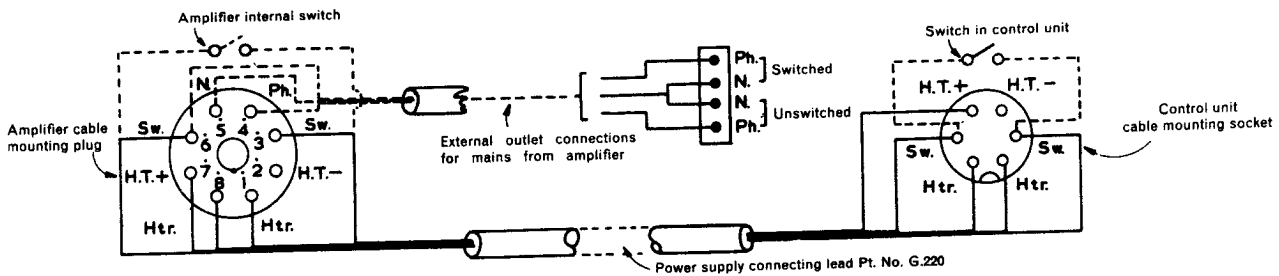
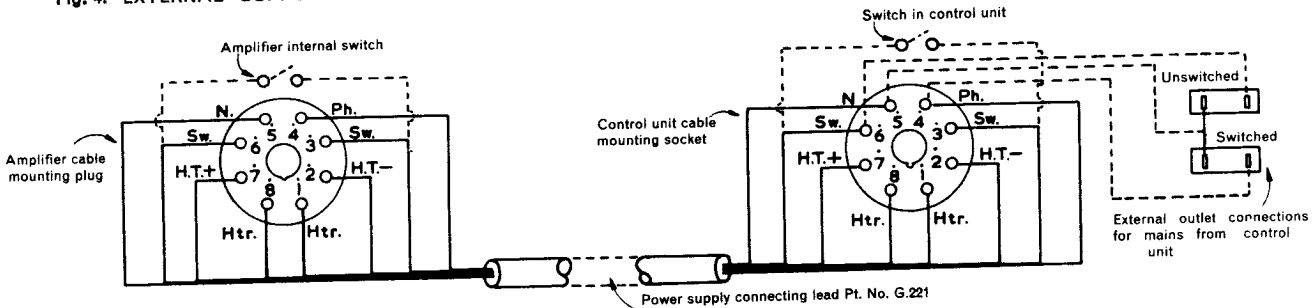

Fig. 4. EXTERNAL SUPPLY CONNECTION ARRANGEMENTS FOR SC22 CONTROL UNIT



9:2 Life expectancy of component parts

As a guide to frequency of replacements, the possible life of parts used in Radford equipment is given below.

9:2:1 Valves

The valves most likely to require replacement first are those consuming power, i.e. rectifiers and power output valves. Power output valves in Radford amplifiers are deliberately under-run for many reasons, one of which is long life. If amplifiers are used for some hours every day the emission life should be approximately 2-3 years for power and rectifier valves and about 7 years for other valves. This excludes the possibility of an absolute failure of any type of valve.

9:2:2 Fuses

Fuses wear thin and may "blow" after a few years use. This does not imply any fault in the equipment, but if fuses need frequent replacement the equipment should be checked. The fuses used in Series 3 amplifiers are:—

	MA 15	STA 15	MA 25	STA 25
Mains Primary Fuse				
100/140 v Range	2A	3A	2.5A	3.0A
200/250 v Range	1A	2A	1.5A	2.5A

9:2:3 Electrolytic capacitors

Providing equipment is regularly used, the life should be a minimum of 10 years.

9:2:4 Transformers

Transformers are designed on a Class "A" rating basis with a life expectancy of 21 years continuous duty. Deterioration of the insulating materials takes place as a function of temperature and time. If the transformer is over-run due to the failure of a valve or other components the life expectancy may be reduced.

9:2:5 Other Components

All other components have a considerable life potential but absolute failure is a possibility at any time, although remote.

9:3 Service adjustments

9:3:1 Replacements of parts

The service of amplifiers is very simple for the experienced mechanic or technician. Component boards are printed with the circuit references. The 'Technical Instruction' T.I (A) 1. should be studied to enable the circuit diagrams to be properly understood.

9:3:2 Checking performance characteristics

The performance characteristics given in the sales leaflet can be measured providing suitable apparatus is available. Technical instructions are being prepared to show how the tests should be carried out. They will be available to Dealers on request.

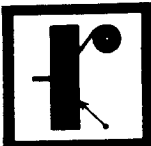

Radford
Electronics Ltd

Ashton Vale Estate
Bristol 3. England. Tel 662301/2

BASIC AMPLIFIER CIRCUIT

15 WATTS

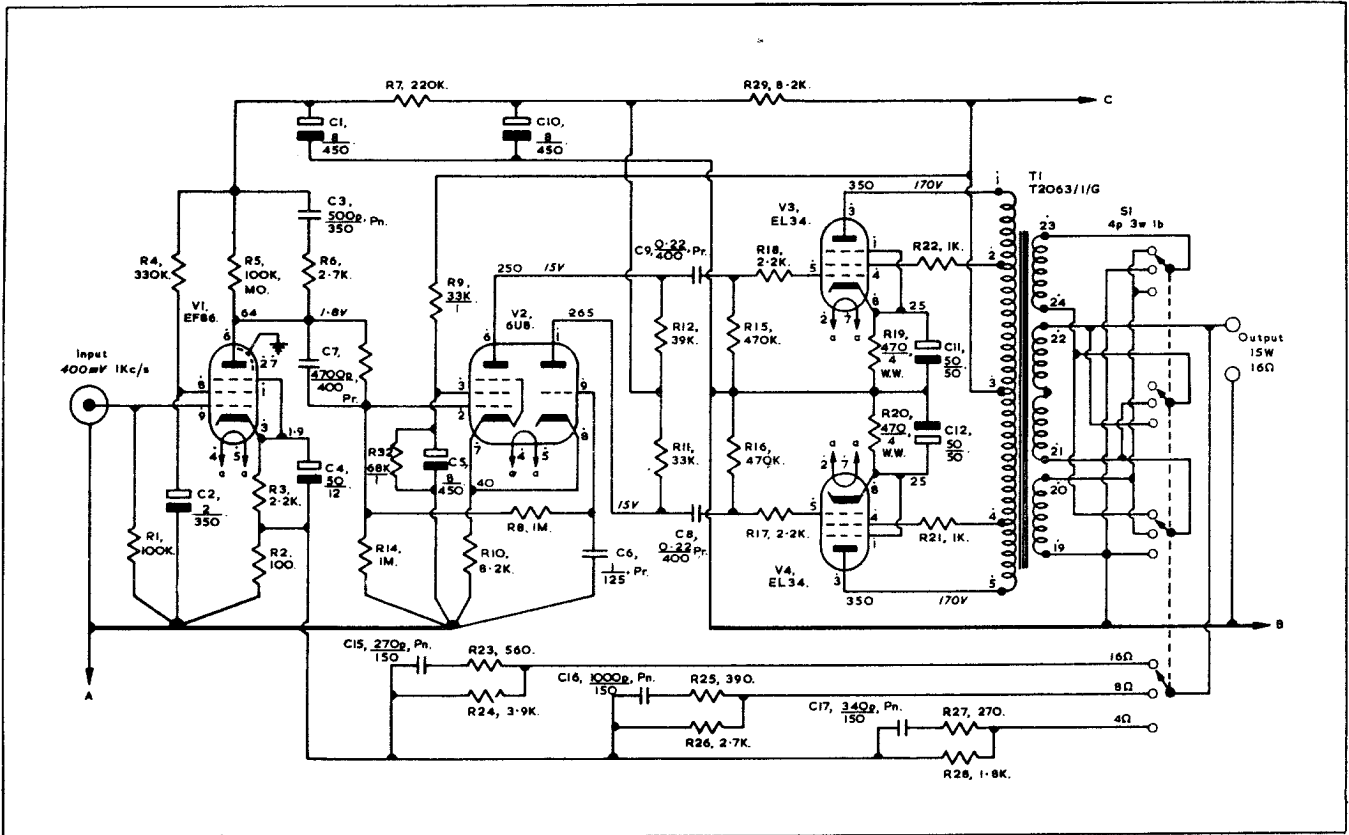

POWER SUPPLY

MA 15

STA 15

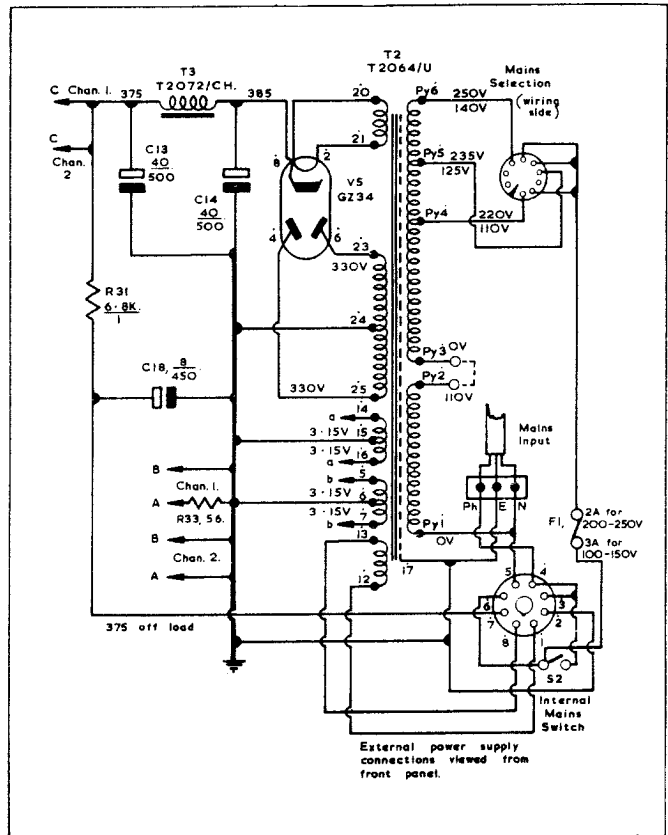
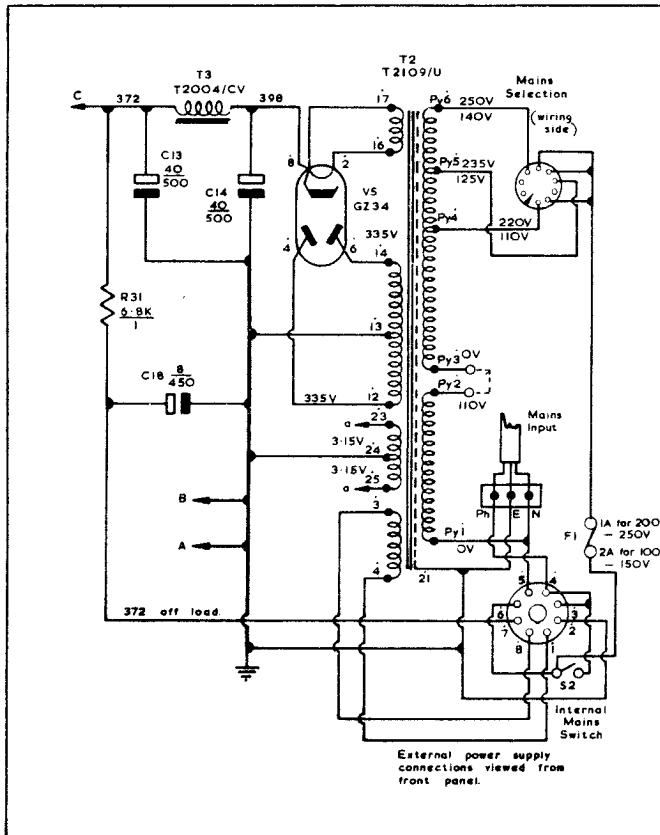

BASIC AMPLIFIER CIRCUIT

25 WATTS

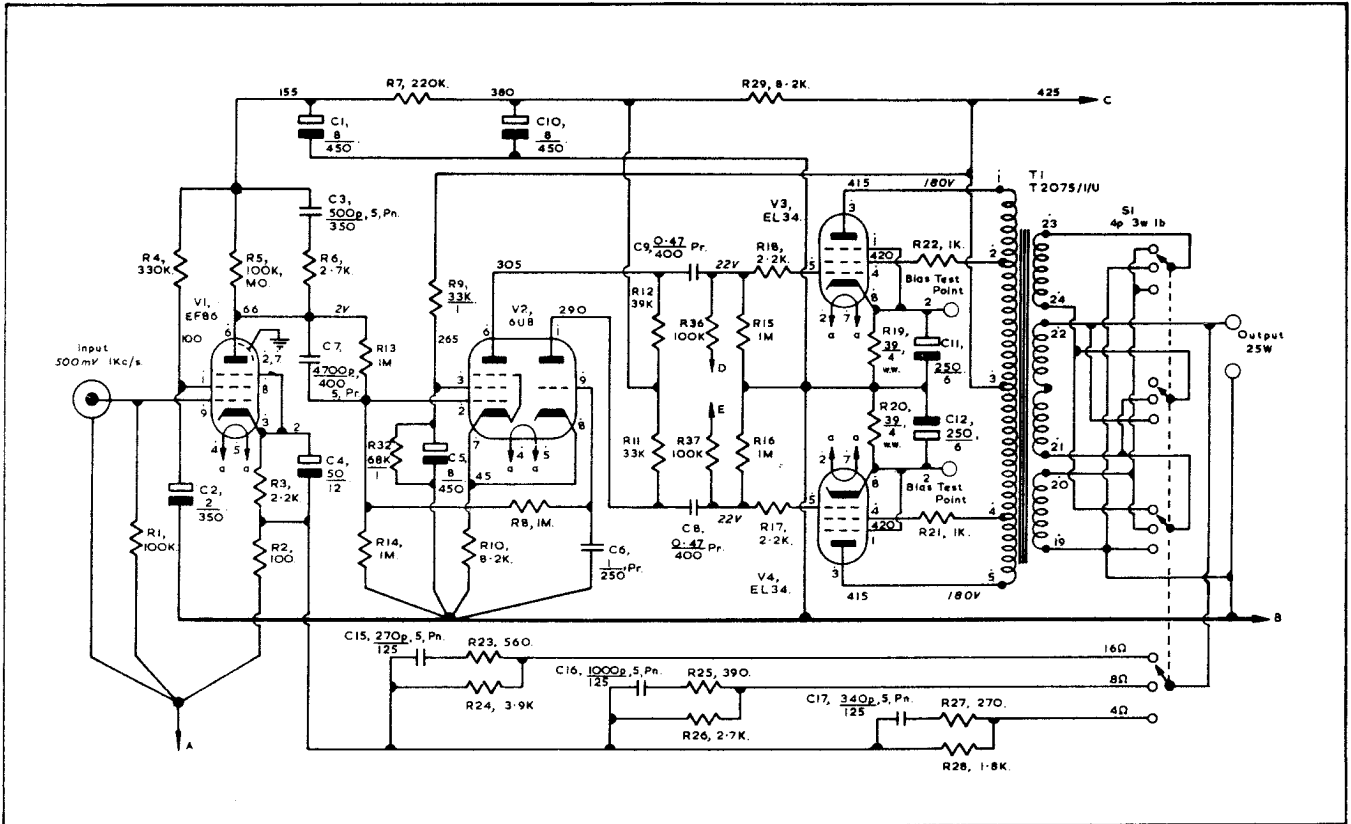

POWER SUPPLY

MA 25

STA 25

