

DELAY TRIGGERED SWEEP OSCILLOSCOPE

HIGH STABILITY

CS-1830

DUAL TRACE OSCILLOSCOPE

INSTRUCTION MANUAL



FEATURES

- The vertical axis provides high sensitivity (5 mV/div) and wide bandwidth 30 MHz (-3 dB). [2 mV, 20 MHz (-3 dB) with 5 ▶ 2 mV switch]
- The CRT has a rectangular with internal graticule, post deflection accelerator with domed mesh to eliminate parallax errors.
- Delay sweep function that enlarges any given portion of signal for easy observation.
- ALT delay sweep function individually sets for delay and nondelay observations of CH1 and CH2 slopes of internal and external sync signals.
- Fix sync function for automatic synchronization of various waveforms.
- Distortion-free observation of signals up to 30 MHz.
- Selection of 5 sync signals, ALT, CH1, CH2, LINE and EXT.
- Sync coupling for AC, LF REJ, HF REJ, and DC assures stabilized synchronization of various types of waveforms.
- ALT and CHOP switches are provided for ALT or CHOP observation throughout all ranges.
- Auto free-run system enables the trace to be checked even at no-signal time.
- HOLDOFF function for stabilized synchronization of complex signals such as video signals and logic signals.
- X-Y changeover system allows CH1 amplifier to be used as Y axis amplifier and CH2 amplifier as X axis amplifier.
- Single sweep function for observation of a single waveform.
- Spot illumination of CRT permits the waveform on the scale to be photographed.
- The adoption of ICs in the logic changeover circuit provides for improved reliability.

CONTENTS

FEATURES	1
SPECIFICATIONS.....	2
CONTROLS ON PANELS	4
Front Panel	4
Side Panel	8
Rear Panel	8
OPERATION	9
Preliminary Operation	9
Operating Procedures	9
Triggering.....	10
Delay Sweep.....	12
Photographing	13
Measurements of Pulse Rising(Falling) Time.....	14
APPLICATIONS	15
Dual-trace Applications	15
Single-trace Applications	21
FM Receiver Adjustments	23
X-Y Application.....	24
Delay Sweep Applications	26
PRECAUTIONS	27
MAINTENANCE AND ADJUSTMENT	28
Maintenance	28
Adjustment	28
SCHEMATIC DIAGRAM	33

SPECIFICATIONS

Cathode Ray Tube

Type:
140 CGB 31

Acceleration voltage:
6 kV

Scale:
8 div × 10 div (1 div = 9.5 mm)

Vertical Axis (CH1 and CH2)

Deflection Factor:
2 mV/div — 5 V/div ± 3%

Attenuator:
5 mV/div to 5 V/div in 1-2-5 sequence.
Variable between ranges, ±5% on all ranges.

Input impedance:

1 MΩ ± 2%
23 pF ± 3 pF

Frequency response:

DC DC — 30 MHz (within —3dB) at 5 mV/div —0.2V/div
[DC — 20 MHz (within —3dB) at PULL 2 mV/div]

AC 5 Hz — 30 MHz (within —3dB) at 5 mV/div —0.2V/div
[5 Hz — 20 MHz (within —3dB) at PULL 2 mV/div]

Risetime:

11.7 nsec (30 MHz) or less, 17.5 nsec (20 MHz) or less.

Overshoot:

3% or less (100 kHz square wave)

Crosstalk:

Better than —60 dB (alternate), better than —40 dB (chop).

Operating modes:

CH1 CH1 only
CH2 CH2 only
DUAL Dual trace
ADD Single trace algebraic sum of CH1 and CH2 (single trace algebraic difference of CH1 and CH2 when CH2 signal is inverted.)

Dual-trace Changeover

TRIG SOURCE in ALT position: Alternate trace in all SWEEP TIME/DIV ranges.
TRIG SOURCE in any position other than ALT: Trace chopped at PULL CHOP.

CHOP frequency:

Approx. 200 kHz

CH2 polarity:

Normal or inverted

Maximum input voltage:

600 Vp-p or 300V (DC + AC peak)

Maximum undistorted amplitude:

More than 8 div (DC — 30 MHz)

Horizontal Axis (Horizontal input thru CH2 input) [X5 MAG not included]

Deflection factor:

Same as vertical (CH2)

Input impedance:

Same as vertical (CH2)

Frequency response:

DC DC — 2 MHz (within —3 dB)
AC 5 Hz — 2 MHz (within —3 dB)

X-Y operation:

with SWEEP TIME/DIV switch in X-Y position, the CH1 input becomes the Y-axis input and the CH2 input becomes the X-axis input. The X-Y position control become the horizontal position control.

X-Y phase difference:

3° or less at 100 kHz

Sweep Circuit (Common to CH1 and CH2)

Sweep system:

NORM: Triggered sweep.
AUTO: Automatic sweep. Sweep is obtained without input signal.
SINGLE: Single sweep.

Sweep time:

0.2 μs/div to 0.5 s/div in 20 calibrated ranges, in 1-2-5 sequence. Variable between ranges, Sweep time accuracy: ±3%.

Sweep magnification:

Obtained by enlarging the above sweep 5 times (±10%) from center.

Linearity:

±3% (±10% for 0.5 μs and 0.2 μs/div ranges with X5 MAG)

Triggering Source:

Internal:

ALT Triggered by CH1 or CH2 vertical input signal.
CH1 Triggered by CH1 input signal.
CH2 Triggered by CH2 input signal.
LINE Triggered by power line frequency.

External

EXT Triggered by an external signal applied to EXT TRIG jack.

Maximum input voltage:

50V (DC + AC peak)

Type:

Normal (NORM), automatic (FIX).
In automatic mode, the sweep triggers automatically without an input signal.

Frequency:

AC, LFREJ, HFREJ, and DC

Sensitivity (Based on sine wave):

Coupling	Bandwidth (Hz)	Minimum Sync Voltage	
		INT (div)	EXT (Vp-p)
AC	20 ~ 25M	0.5	1
	10 ~ 30M	1	5
DC	DC ~ 25M	0.5	1
	DC ~ 30M	1	5
FIX	40 ~ 20M	0.5	2
	20 ~ 25M	1	5
LF REJ HF REJ	Attenuate below 10 kHz. Attenuate above 100 kHz.		

Video Sync:

FRAME — LINE switch permits triggering from horizontal (LINE) or vertical (FRAME) sync pulses of composite video signal.

HOLDOFF:

Continuously variable from zero (NORM) to more than 10 times (MAX).

Delay Sweep

Delay time:

1 μs to 100 ms in 5 ranges with vernier adjustment.

ALT:

With ALT triggering source, channel 1 or channel 2 sweep can be independently delayed.

Jitter:

5,000: 1

Intensity modulation:

INTEN switch allows portion of sweep after delay to be intensified.

Calibration voltage:

Square wave, positive polarity
0.5V ±1%, reference level 0V
1 kHz ±3%

Intensity Modulation

Input voltage:

More than +2V (TTL compatible)

Input impedance:

10 kΩ

Bandwidth:

DC — 5 MHz

Maximum input voltage:

50V (DC + AC peak)

Trace rotation:

Trace angle adjustable on front panel

Power Requirements

Power supply voltage:

AC 100/120/220/240V ±10%, 50/60 Hz

Power consumption:

Approx. 30W

Dimensions

Width: 260 mm (277 mm)
Height: 190 mm (204 mm)
Depth: 375 mm (440 mm)
Figures in () show maximum size.

Weight:

Approx. 8.6 kg

Accessories

Probe (PC — 22) 2 pieces
Attenuation 1/10
Input impedance 10 MΩ,
less than 18 pF

Replacement fuse
0.7A 2
0.3A 2
Instruction manual 1 copy

CONTROLS ON PANELS

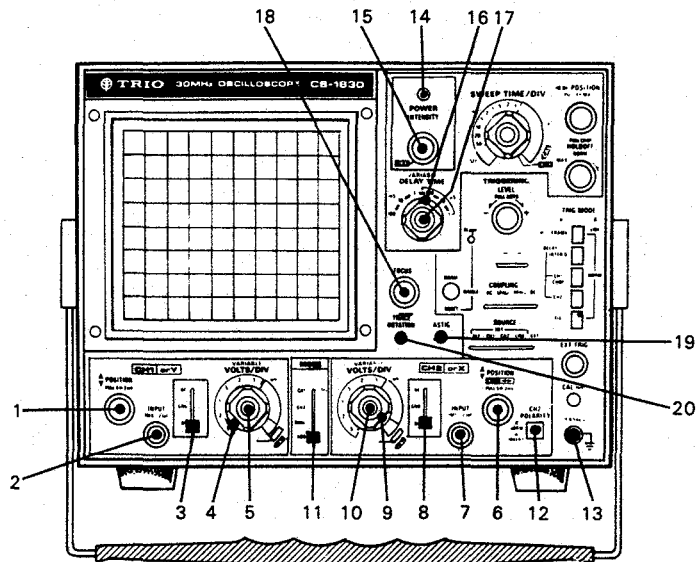

Fig. 1 Front panel controls and indicators

Controls on Front Panel

1. \blacktriangleleft POSITION/PULL 5 \blacktriangleright 2mV

Rotation adjusts vertical position of channel 1 trace. In X-Y operation, rotation adjusts vertical position of display. Push-pull switch (PULL 5 \blacktriangleright 2 mV) selects channel 1 sensitivity when VOLTS/DIV switch is set to most sensitive range. Pull for 2 mV/div sensitivity, push for 5 mV/div sensitivity.

2. INPUT

Vertical input terminal for CH1, and Y input terminal for X-Y operation.

3. AC-GND-DC

Three-position lever switch which operates as follows:

- AC** Blocks dc component of channel 1 input signal.
- GND** Opens signal path and grounds input to vertical amplifier. This provides a zero-signal base line, the position of which can be used as a reference when performing dc measurements.
- DC** Direct input of ac and dc component of channel 1 input signal.

4. VOLTS/DIV

Vertical attenuator for channel 1; provides step adjustment of vertical sensitivity. When VARIABLE control (5) is set to CAL, vertical sensitivity is calibrated in 10 steps from 5V/div to 5 mV/div (2 mV/div when POSITION control is pulled).

5. VARIABLE

Rotation provides fine control of channel 1 vertical sensitivity. In the fully clockwise (CAL) position, the vertical attenuator is calibrated.

6. \blacktriangleleft POSITION/X-Y \blacktriangleright /PULL 5 \blacktriangleright 2 mV

Rotation adjusts vertical position of channel 2 trace. In X-Y operation rotation adjusts horizontal position of display. Push-pull switch (PULL 5 \blacktriangleright 2 mV) selects channel 2 sensitivity when VOLTS/DIV switch is set to most sensitive range. Pull for 2 mV/div sensitivity, push for 5 mV/div sensitivity.

7. INPUT

Vertical input terminal for CH2 or X input terminal for X-Y operation.

8. AC-GND-DC

Three-position lever switch which operates as follows:

- AC** Blocks dc component of channel 2 input signal.
- GND** Opens signal path and grounds input to vertical amplifier. This provides a zero-signal base line, the position of which can be used as a reference when performing dc measurements.
- DC** Direct input of ac and dc component of channel 2 input signal.

9. VOLTS/DIV

Vertical attenuator for channel 2; provides step adjustment of vertical sensitivity. When VARIABLE control (10) is set to CAL, vertical sensitivity is calibrated in 10 steps from 5 V/div to 5 mV/div (2 mV/div when POSITION control is pulled). In X-Y operation, this control provides steps adjustment of horizontal sensitivity.

10. VARIABLE

Rotation provides fine control of channel 2 vertical sensitivity. In the fully clockwise (CAL) position, the vertical attenuator is calibrated. In X-Y operation, this control becomes the fine horizontal gain control.

11. MODE

Four-position lever switch which operates as follows:

- CH1:** Only the input signal to CH1 is displayed as a single trace.
- CH2:** Only the input signal to CH2 is displayed as a single trace.
- DUAL:** Dual trace operation; both the CH1 and CH2 input signals are displayed on two separate trace. With SOURCE (21) in ALT position, ALT operation is effected independently of other switches. With SOURCE in any position other than ALT, CHOP operation at about 200 kHz is effected provided PULL CHOP switch (33) is pulled. For ALT operation, depress this switch.
- ADD:** The waveforms from channel 1 and channel 2 inputs are added and the sum is displayed as a single trace. When the CH 2 POLARITY button is engaged (INV), the waveform from channel 2 is subtracted from the channel 1 waveform and the difference is displayed as a single trace.

12. CH2 POLARITY

In the NORM position (button released), the channel 2 signal is non-inverted. In the INV position (button engaged), the channel 2 signal is inverted.

In the ADD mode, and this switch in INV, the channel 2 signal is subtracted from the channel 1 signal and the difference is displayed as a single trace.

13. GND

GND terminal.

14. LED Pilot Lamp

This lamp lights when POWER (15) is ON.

15. POWER/INTENSITY

Fully counterclockwise rotation of this control (OFF position) turns off oscilloscope. Clockwise rotation turns on oscilloscope. Further clockwise rotation of the control increases the brightness of the trace.

16. DELAY TIME

Range selector switch permits coarse selection of delay time for delayed sweep operation (this control has no effect unless one or more of the TRIG DELAY button is engaged ... INTEN, CH 1 DLY'D, or CH 2 DLY'D).

Five ranges of 1 to 10 μ s, 10 to 100 μ s, .1 to 1 ms, 1 to 10 ms, and 10 to 100ms.

17. VARIABLE

Fine adjustment of delay time within selected range. Fully counterclockwise rotation is minimum delay time, clockwise rotation increases delay time.

18. FOCUS

Spot focus control to obtain optimum waveform according to brightness.

19. ASTIG

Astigmatism adjustment provides optimum spot roundness and brightness when used in conjunction with FOCUS (18) and INTENSITY (15) control. Very little readjustment of this control is required after initial adjustment.

20. TRACE ROTATION

This is used to eliminate inclination of horizontal trace.

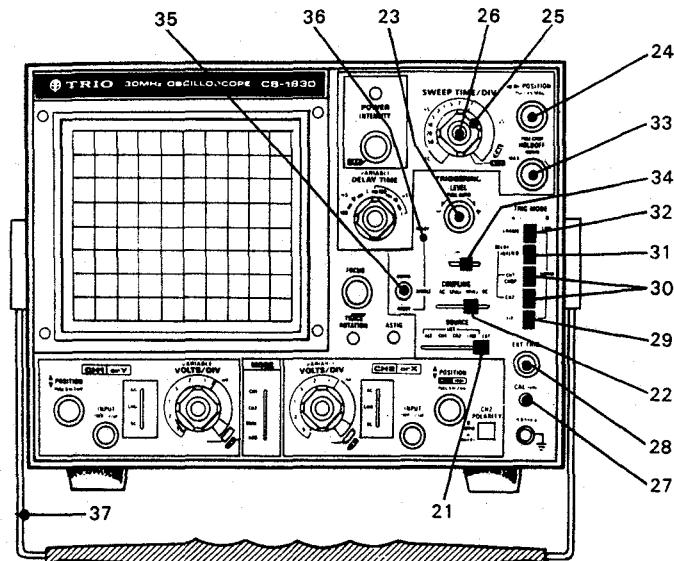

Fig. 2 Front panel controls and indicators

21. SOURCE

Five-position lever switch selects triggering source for the sweep, with the following positions:

- ALT** Alternate triggering in DUAL mode; channel 1 trace is triggered by channel 1 signal and channel 2 trace is triggered by channel 2 signal. Scope operates in alternate sweep method regardless of setting of PULL CHOP switch.
- In CH 1 and ADD mode, sweep is triggered by channel 1 signal.
- In CH 2 mode, sweep is triggered by channel 2 signal.
- CH 1** Sweep is triggered by channel 1 signal regardless of MODE selection.
- CH 2** Sweep is triggered by channel 2 signal regardless of MODE selection.
- LINE** Sweep is triggered by line voltage.
- EXT** Sweep is triggered by signal applied to EXT TRIG jack.

22. COUPLING

Four-position lever switch with the following positions:

- AC** Trigger is ac coupled. 10 Hz to 30 MHz response.
- LF Rej** Triggering below 10 kHz is attenuated.
- HF Rej** Triggering above 100 kHz is attenuated.

DC Trigger is dc coupled. DC to 30 MHz response.

23. LEVEL/PULL AUTO

Trigger level adjustment determines point on waveform where sweep starts. Rotation in (-) direction selects more negative point of triggering, and rotation in (+) direction selects more positive point of triggering. Push-pull switch selects automatic triggering when pulled out (PULL AUTO). With automatically triggering, a sweep is generated automatically (free runs) in the absence of trigger signal; reverts to triggered sweep operation in the presence of adequate trigger signal.

24. ◀ POSITION/PULL X 5MAG

Rotation adjusts horizontal position of trace (both traces in DUAL mode). Push-pull switch selects X5 magnification (PULL X5 MAG) when pulled out; normal when pushed in.

25. SWEEP TIME/DIV

Horizontal coarse sweep time selector. Selects calibrated sweep times of 0.2 μ s/div (microsecond per division) to 0.5 s/div in 20 steps when sweep time VARIABLE control is set to CAL position (fully clockwise).

In the X-Y position, this switch disable the internal sweep generator and permits the X-Y input to provide horizontal deflection (X-Y operation).

26. VARIABLE

Fine sweep time adjustment. In the extreme clockwise (CAL) position the sweep time is calibrated.

27. CAL

Provides 1 kHz, 0.5-volt peak-to-peak square wave signal. This is useful for probe compensation adjustment and a general check of oscilloscope calibration accuracy.

28. EXT TRIG

Input for external trigger signal. External trigger signal is applied to this terminal with SOURCE (21) set to EXT position.

29. NORMAL/FIX

In the FIX position (button engaged), the triggering level is automatically fixed at the center of the triggering waveform, regardless of the position of the LEVEL control.

In the NORM position, (button released), variable triggering level is enabled.

30. NORM/DELAY CH1, CH2

Delay setting switch. CH1 is delayed by pressing the CH1 switch and CH2 delayed by the CH2 switch regardless of the position of the DELAY INTEND (32).

In ALT mode, CH1 and CH2 are delayed or non-delayed individually by using CH1 and CH2 switches.

In CHOP mode, CH1 and CH2 are delayed simultaneously by pressing the DELAY CH1 (CHOP) switch. The DELAY CH2 switch has no effect on delay operation. In normal mode, normal sweep is obtained.

31. NORM/DELAY INTEN'D

NORM: The brightness adjusted by INTENSITY is unmodulated.

DELAY INTEN'D: The brightness of the spot determined by DELAY TIME (16) and VARIABLE (17) is modulated. Modulation is released by pressing DELAY CH1, CH2.

32. NORM (LINE)/FRAME

In the FRAME position (button engaged), vertical sync pulses of a composite video signal are

selected for triggering. In the LINE position (button released), horizontal sync pulses of a composite video signal are selected for triggering. The LINE position is also used for all non-video waveforms.

33. HOLDOFF/PULL

Rotation adjusts holdoff time (trigger inhibit period beyond sweep duration). Fully counterclockwise rotation is NORM, clockwise rotation increases holdoff period. Push-pull switch selects chop or alternate method of dual-trace generation; chop when pulled out (PULL CHOP), alternate when pushed in (except alternate method is always selected when SOURCE switch is in ALT position).

34. SLOPE

Two-position lever switch with the following positions:

- +** Sweep is triggered on positive-going slope of waveform, or with positive sync pulse of composite video waveform.
- Sweep is triggered on negative-going slope of waveform, or negative sync pulse of composite video waveform.

35. NORM, SINGLE, RESET

Three-position toggle switch with the following positions:

NORM Normal sweep, used for all types of operation except single sweep.

center

RESET This is a momentary action position; switch returns to center position when released. Enables single sweep operation. A single sweep will begin when the next sync trigger occurs. After a single sweep, switch must be momentarily RESET to enable next single sweep. When held in RESET position, spot illumination brightens the entire CRT screen to accentuate the graticule scale for waveform photographs.

36. READY

Lights to indicate single sweep operation is ready for triggering. Lights when RESET switch is operated and goes off when single sweep is completed.

37. HANDLE

This handle also serves as a stand of the oscilloscope.

CONTROLS ON SIDE PANEL

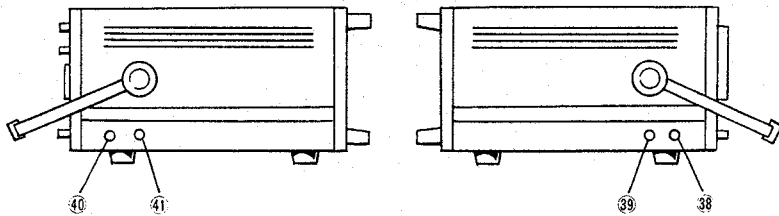

Fig. 3 Side panel facilities

38. VARI. ATT. DC BAL

For adjustment of CH1 (or Y) vertical DC balance. Adjustment should be made so that the waveform position is not shifted when VARIANLE (5) is turned.

39. STEP. ATT. DC BAL

For adjustment of CH1 (or Y) vertical DC balance. Adjustment should be made so that the waveform position is not shifted when VOLTS/DIV (4) is turned.

40. VARI. ATT. DC BAL

For adjustment of CH2 (or X) vertical DC balance. The function of this control is the same as that of VARI. ATT. BAL. (38).

41. STEP. ATT. DC BAL

For adjustment of CH2 (or X) vertical DC balance. The function of this control is the same as that of STEP. ATT. BAL. (39).

CONTROLS ON REAR PANEL:

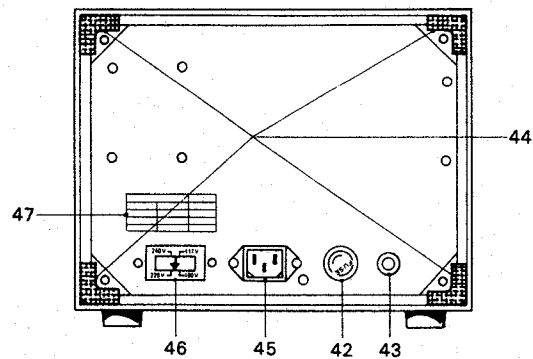

Fig. 4 Rear panel facilities

42. Fuse Holder

Fuse rated at 0.5A should be used for 220/240V operation. For operation on 100/120V, be sure to use a 0.7A fuse.

43. Z AXIS INPUT

Intensity modulation terminal. Intensity is modulated at voltages of more than +2V.

44. Cord Reel

Wind power cord when the oscilloscope is to be carried or stored. They also serve as a stand when

the oscilloscope is used in upright position.

45. Power Connector

AC power connector. For connection, use the supplied cord.

46. Power Voltage Selector

Set this switch to the correct operating voltage.

47. Voltage Indicating Plate

Use voltages and fuses specified.

OPERATION

PRELIMINARY OPERATION

To ensure correct operation, set the oscilloscope as illustrated below before switching on the power.

For detailed instructions, refer to "Controls on Panels".

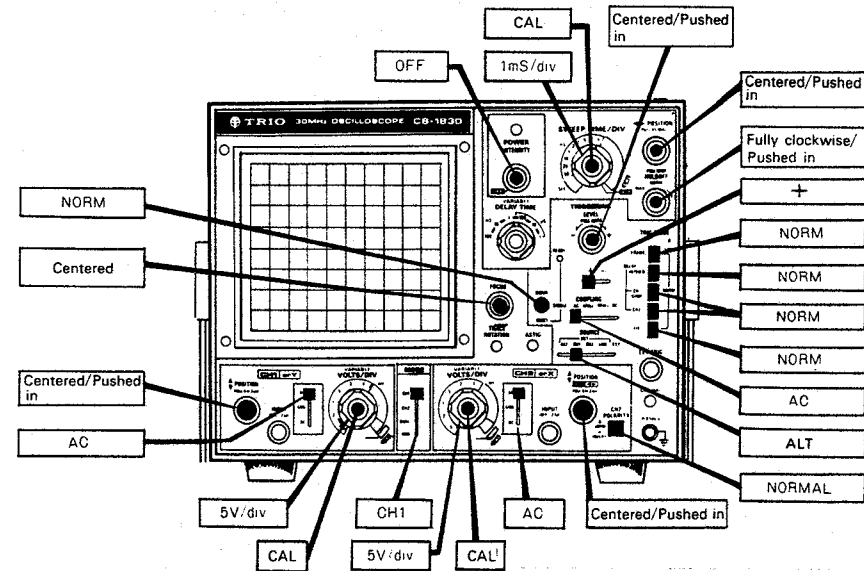

Fig. 5 Initial setting

OPERATING PROCEDURES (figures in [] denote CH2)

1. Set the power voltage selector to the correct voltage observing the arrow mark on the plug.
2. Turn POWER (15) clockwise. The power is turned to ON and LED pilot lamp (14) lights.
3. Trace will be displayed. If no trace appears at the center of the screen, adjust POSITION (1) [6]. Adjust brightness with INTENSITY (15). If trace is unclear, adjust FOCUS (18).
4. The oscilloscope is now ready for measurement. For measurement, proceed as follows: Apply a signal voltage to INPUT (2) [7]. Then turn VOLTS/DIV (4) [9] clockwise until the waveform is correctly displayed on the scope. By setting MODE (11) and SOURCE (21) to CH1, the CH1 input signal to INPUT (2) will appear. Similarly, by setting MODE and SOURCE to CH2, then the input signal to CH2 INPUT (7) will appear. At DUAL position, two waveforms are displayed on the screen. Dual-trace sweep is generated by two methods: alternate and chop. At ADD position, algebraic sum of CH1 and

CH2 (CH1 + CH2) is obtained. When PULL INVERT (7) knob is pulled, the input to CH2 is applied to CH1 in reverse polarity and thus the algebraic difference (CH1 - CH2) is obtained.

5. When the signal voltage is more than 5mV and waveform fails to appear on the screen, the oscilloscope may be checked by feeding input from CAL (27). Since calibration voltage is 0.5V, the waveform becomes 5 div at the 0.1V/div position on VOLTS/DIV.
6. By setting LEVEL (23) to NOR position, the free-running auto function is released. The waveform disappears when LEVEL is turned clockwise or counterclockwise and appears again at the approximate middle position of it. In both NOR and AUTO modes, triggering level can be adjusted.
7. When DC component is measured, set AC-GND-DC (3) [8] to DC. If, in this case, the DC component contains "+" potential, the waveform moves upward and if it contains "-" potential, the waveform moves downward. The reference point of "0" potential can be checked at GND position.

TRIGGERING

To observe a stationary input signal waveform, the sweep circuit must be triggered correctly. This can be accomplished either by the input signal (internal triggering) or by applying a signal, having a specific relationship (integer multiple) with input signal in terms of time, to the external trigger terminal (external triggering).

Internal Triggering:

By setting TRIGGERING SOURCE (21) to INT (ALT CH1, CH2 or LINE), the input signal is connected to the internal trigger circuit. In this position, a part of the input signal fed to the input terminal (2 or 7) is applied from the vertical amplifier to the trigger circuit to cause the trigger signal triggered with the input signal to drive the sweep circuit.

External Triggering:

External triggering is accomplished by setting the SOURCE switch (21) to EXT provided a trigger signal is applied to the external trigger input terminal (2B). External triggering is useful when you wish to trigger with a signal different from the input signal. It should be noted, however, that the trigger signal must have a relationship with the input signal in terms of time to ensure effective observation of waveform.

Fig. 6 shows that the sweep circuit is driven by the gate signal when the gate signal in the burst signal is applied to the input terminal.

Fig. 6 also shows the input/output signals, where the burst signal generated from the gate signal is applied to the instrument under test.

Thus, accurate triggering can be achieved without regard to the input signal fed to the terminals (2) and (7), so that no further triggering is required even when the input signal is varied.

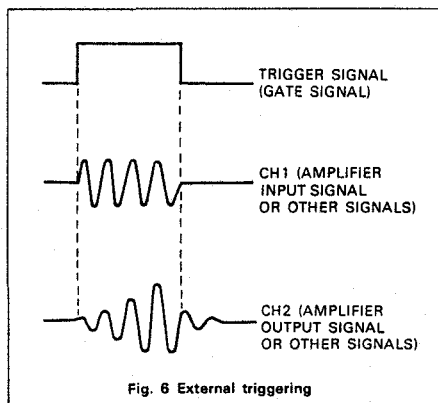

Coupling:

The COUPLING switch (22) selects the coupling mode of the trigger signal to the trigger circuit according to the type of trigger signal (DC, AC, signal superposed on DC, signal with low frequency noise, signal with high frequency noise, etc.).

AC:

The AC (capacitance) coupling permits triggering by the AC component only; the DC component of the trigger signal is cut off. This range is normally used triggering is stabilized without regarding to the DC component. Note that if the frequency of the trigger signal is less than 10 Hz, the signal level becomes low which results in difficulty of triggering.

LF REJ:

The trigger signal is fed to the trigger circuit via a high pass filter where the low frequency component (less than 10 kHz) is eliminated and thus triggering is effected only by the high frequency component.

As shown in Fig. 7, when the trigger signal contains low frequency noise (particularly hum), it is eliminated so that triggering is stabilized.

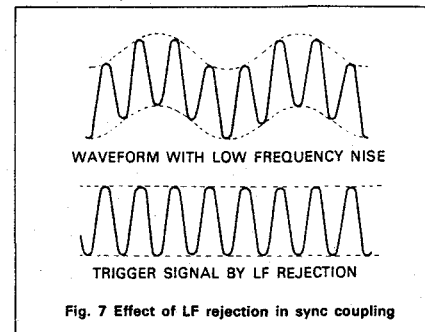

HF REJ:

In contrast with LF REJ, the trigger signal is fed via a low pass filter where high frequency component (more than 100 kHz) is eliminated and thus triggering is effected only by the low frequency component. Fig. 8 shows that the high frequency noise contained in the waveform is eliminated so that triggering is stabilized.

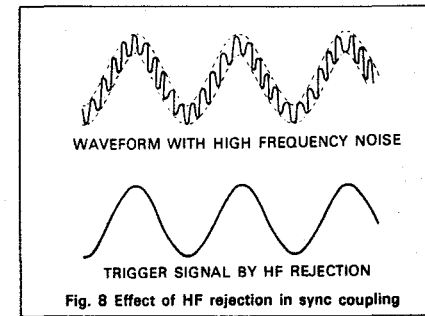

DC:

Permits triggering from DC to over 30 MHz. Couples DC component of sync trigger signal. Useful for triggering from very low frequency signals (below 10 Hz), or ramp waveforms with slow repeating DC.

Triggering Level:

Trigger point on waveform is adjusted by the LEVEL (23) and SLOPE (34) controls. Fig. 9 shows the relationship between the SLOPE and LEVEL of trigger point. Triggering level can be adjusted as necessary.

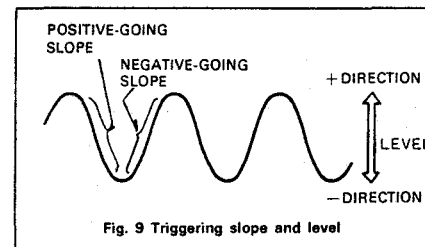

Auto Trigger:

By setting MODE (23) to AUTO the sweep circuit becomes free-running as long as there is no trigger signal, permitting a check of GND level. When a trigger signal is present, the trigger point can be determined by the LEVEL and SLOPE for observation as in the normal trigger signal. When the triggering level exceeds the limit, the trigger circuit also becomes free-running where the waveform starts running. When LEVEL is in NOR position, there is no sweeping nor trace when trigger signal is absent or the triggering level exceeds the limit.

FIX:

When NORM/FIX(29) is set to FIX, triggering is

always effected in the center of waveform, eliminating the need for adjusting the triggering level. As shown in Fig. 10 (A) or (B), when NORM/FIX set to NOR and the triggering level is adjusted to either side of the signal, the trigger point is deviated as the input signal becomes small which, in turn, stops the sweep operation.

By setting NORM/FIX to FIX, the triggering level is automatically adjusted to the approximate center of the waveform and the signal is synchronized regardless of the position of LEVEL as shown in Fig. 10 (c).

When the input signal is suddenly changed from a square waveform to a pulse waveform, the trigger point is shifted extremely toward the "—" side of the waveform unless the triggering level is readjusted as shown in Fig. 11 (A). See Fig. (A)-(2), (3).

Also, if the trigger point has been set to the "—" of square waveform (Fig. 11 (B)-(1)) and the input signal is changed to a pulse signal, the trigger point is deviated and the sweeping stops. When this happens, set FIX/NORM to FIX position and the triggering is effected in the approximate center of the waveform, making it possible to observe a stabilized waveform. Fig. 11 (C).

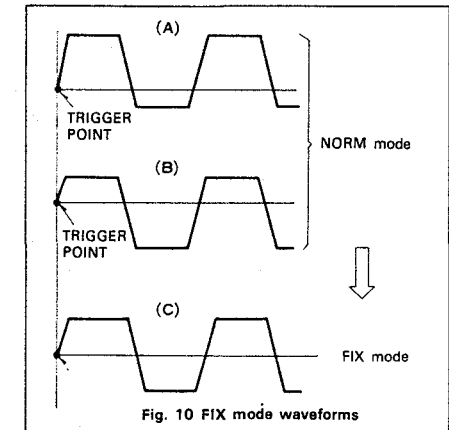

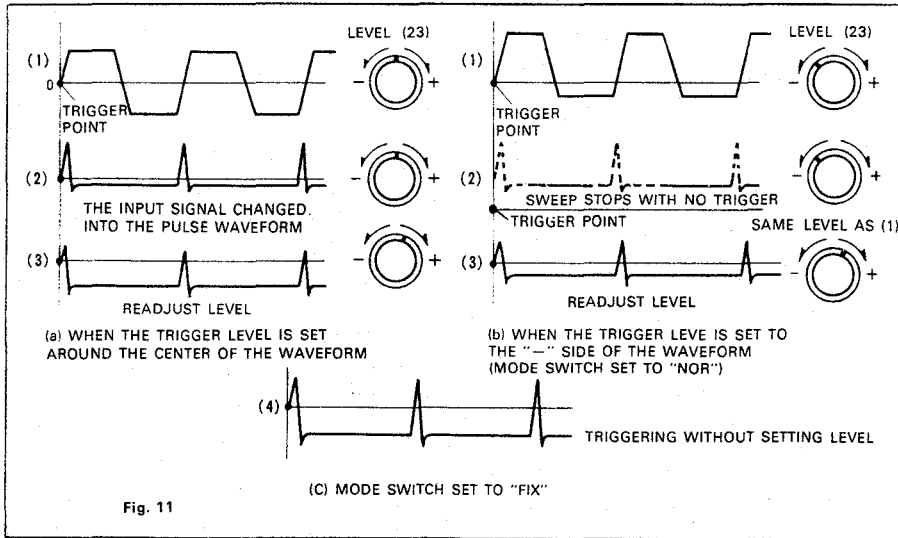

Fig. 11

DELAY SWEEP

Any desired portion of waveform can be magnified for easy observation (Fig. 12 shows an example of observation of the enlarged rising portion of square wave).

1. Using SWEEP TIME/DIV (25), read the approximate delay time of the portion to be magnified (about 3.5 ms in Fig. 12-a).
2. Next, set DELAY TIME (16) to the range which includes the delay time (10-1 ms range in Fig. 12-a).
3. Press INTEN'D (31) and the waveform is partially intensity modulated. Turn VARIABLE (17) so that the starting point of the portion to be magnified comes to the left end of the modulated waveform (Fig. 12-b).
4. Press DELAY (30) corresponding to the channel to be observed and delay sweep is effected starting at the set point (Fig. 12-c).
5. Under this condition, adjust SWEEP TIME/DIV (25) and the desired portion of the waveform can be magnified (In Fig. 12-d, SWEEP TIME/DIV (25) is set to 0.2 ms/DIV

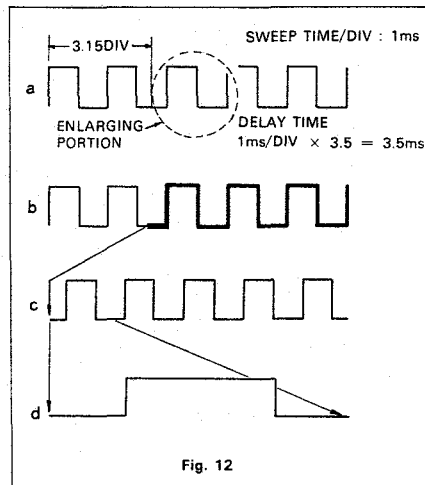

Fig. 12

If it is desired to observe the same input in dual-trace mode, follow the above steps 1, 2 and 3 and then press either CH1 or CH2 DELAY (30). In this way, one channel can be observed in normal sweep and the other in delay sweep, thus permitting comparison of two waveforms.

Triggering with HOLDOFF:

When a series of complex pulses appear periodically as shown in Fig. 13, it sometimes happens that the waveform is displayed twice without being synchronized as illustrated in Fig. 14 depending on the setting of sweep time. In this case, the waveform can be synchronized by continuously varying the sweep time with SWEEP VARIABLE (26), but this method is unpractical because the time base is not calibrated. To obtain stabilized synchronization, turn HOLD-OFF (33) slowly clockwise from the NOR position to change the sweep cycle (time base remains the same) so that the sweeping is started at the same point of the waveform at all times. If a jitter appears when trigger level is adjusted to the maximum setting, adjust the HOLDOFF control until sync signal is stabilized.

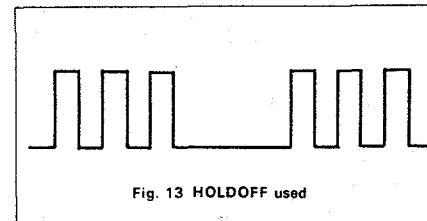

Fig. 13 HOLDOFF used

Single Sweep Operation:

Irregular waveforms of voice signals or instantaneous waveforms (chattering) which occur when mechanical switches are manipulated are displayed twice and cannot be observed clearly if the normal repeating sweep is rised. In this instance, set SINGLE position and the sweeping is made only once with the initial sync signal to permit easy observation. This method is also advantageous when photographing such waveforms. To set the oscilloscope in the trigger standby state after the completion of single sweep, NORM/SINGLE (35) set to RESET (READY lamp (36) will light).

The single sweep will now start again when a sync signal is applied. The READY lamp goes off at the completion of the sweep.

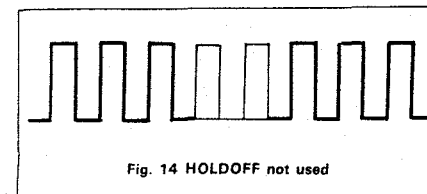

Fig. 14 HOLDOFF not used

PHOTOGRAPHING

The waveform on the scale of CRT screen can be photographed.

Normal sweep

When photographing, be sure to use a camera whose shutter set is not interlocked with the film winder.

1. Apply a signal to be observed to the input terminal and trigger so that the waveform stays still.
2. Under this condition, take a photograph of the waveform.
3. Next, set SWEEP TIME/DIV (25) to 0.1 ms and TRIG LEVEL (23) to PULL AUTO. Then, set NORM/SINGLE switch (35) to RESET and hold the switch in that position. The scale can be photographed by the light of the spot.
4. Adjust the brightness of the scale with INTENSITY (15) and operate the camera for double-exposure. The scale and the waveform can be photographed together.

Single Sweep

1. In NORM sweep, adjust the intensity of the scale with INTENSITY (15) with the oscilloscope operated as outlined in item (3) and take a photograph of the scale. In this case, the shutter speed of the camera should be set to "B".
2. Next, set the camera shutter to "full open" position. Push TRIG LEVEL (23) and turn for optimum triggering, and set NORM/SINGLE switch (35) to SINGLE. Then reset the oscilloscope so that it can be triggered.
3. Apply a signal to be observed to the input terminal.
4. With the signal applied, the oscilloscope completes a sweep and READY goes off. Operate the shutter of the camera.

MEASUREMENTS OF PULSE RISING (FALLING) TIME

The scales 10% and 90% on the CRT screen are used for accurate measurements of pulse rising (falling) time. To measure pulse rising time, proceed as follows:

1. With a pulse signal applied to the input terminal, adjust VOLTS/DIV (4) [9] and VARIABLE (5) [10] so that the pulse amplitude is set to the 0 and 100% scales (Fig. 15).

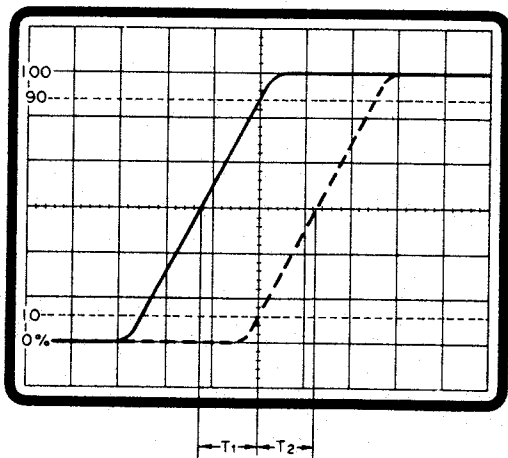

Fig. 15

2. Turn SWEEP TIME/DIV (25) to magnify the rising portion of the waveform as large as possible [VARIABLE (26) should be set to CAL position].
3. Adjust ◀▶ POSITION (24) to set the waveforms at 10% and 90% to the vertical center scale respectively, then measure T1 and T2 using the horizontal center scale. The pulse rising (falling) time is $T1 + T2$.

APPLICATIONS

DUAL-TRACE APPLICATIONS

Introduction:

The most obvious and yet the most useful feature of the dual-trace oscilloscope is that it has the capability for simultaneously viewing two waveforms that are frequency or phase-related, or that have a common synchronizing voltage, such as in digital circuitry. Simultaneously viewing of input and its output is an invaluable aid to the circuit designer or the repairman. Several possible applications of the dual-trace oscilloscope will be reviewed in detail to familiarize the user further in the basic operation of this oscilloscope.

Frequency Divider Waveforms:

Fig. 16 illustrates the waveform involved in a basic divide-by-two circuit. Fig. A indicates the reference or clock pulse train. Fig. B and Fig. C

indicates the possible outputs of the divide-by-two circuitry. Fig. 16 also indicates the setting of specific oscilloscope controls for viewing these waveforms. In addition to these basic control settings, the TRIGGERING LEVEL control, as well as the CH1 and CH2 vertical position controls should be set as required to produce suitable displays. In the drawing of Fig. 16, the waveform levels of 2 div are indicated. The CH2 waveform may be either that indicated in Fig. 16B or Fig. 16C. In Fig. 16C, the divide-by-two output waveform is shown for the case where the output circuitry responds to a negative-going waveform. In this case, the output waveform is shifted with respect to the leading edge of the reference frequency pulse by a time interval corresponding to the pulse width.

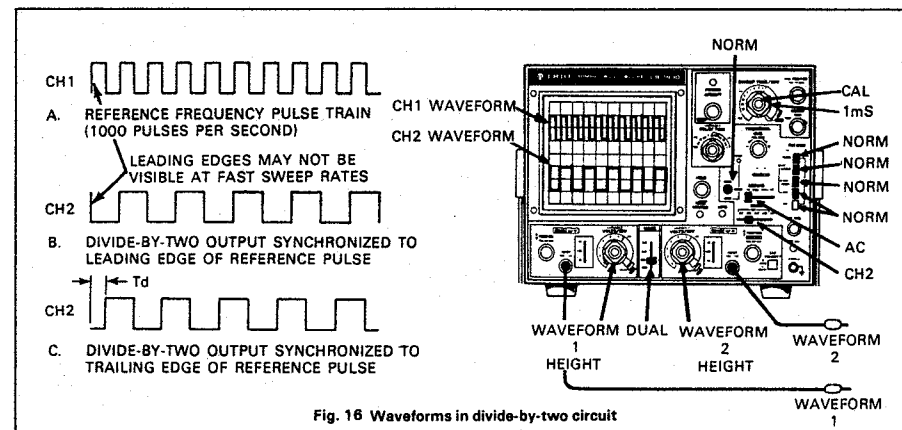

Fig. 16 Waveforms in divide-by-two circuit

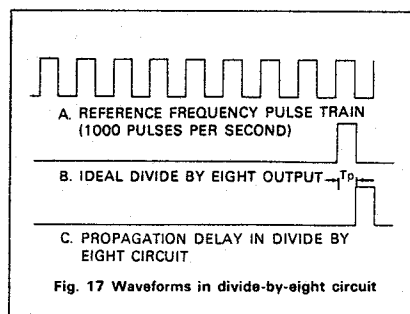

Fig. 17 Waveforms in divide-by-eight circuit

Divide-by-8 Circuit Waveforms:

Fig. 17 indicates waveform relationships for a basic divide-by-eight circuit. The basic oscilloscope settings are identical to those used in Fig. 16. The reference frequency of Fig. 17A is supplied to the CH1 input, and the divide-by-eight output is applied to the CH2 input. Fig. 17 indicates the time relationship between the input pulses and output pulses.

In an application where the logic circuitry is operating at or near its maximum design frequency, the accumulated rise time effects of the consecutive stages produce a built-in time propagation

delay which can be significant in a critical circuit and must be compensated for Fig. 17C indicates the possible time delay which may be introduced into a frequency divider circuit. By use of the dual-trace oscilloscope, the input and output waveforms can be superimposed (ADD or SUB) to determine the exact amount of propagation delay that occurs.

Propagation Delay Time Measurement:

An example of propagation delay in a divide-by-eight circuit was given in the previous paragraph. Significant propagation delay may occur in any circuit with several consecutive stages. This oscilloscope has features which simplify measurement of propagation delay time. Fig. 18 shows the resultant waveforms when the dual-trace presentation is combined into a single-trace presentation by selecting the ADD position of the MODE switch. With CH2 POLARITY switch in the normal position (pushed in) the two inputs are algebraically added in a single-trace display. Similarly, in the inverted position (pulled) the two inputs are algebraically subtracted. Either position provides a precise display of the propagation time (T_p). Using procedures given for calibrated time measurement, T_p can be measured. A more precise measurement can be obtained if the T_p portion of the waveform is expanded horizontally. This may be done by pulling the PULL $\times 5$ MAG control. It also may be possible to view the desired portion of the waveform at a faster sweep speed.

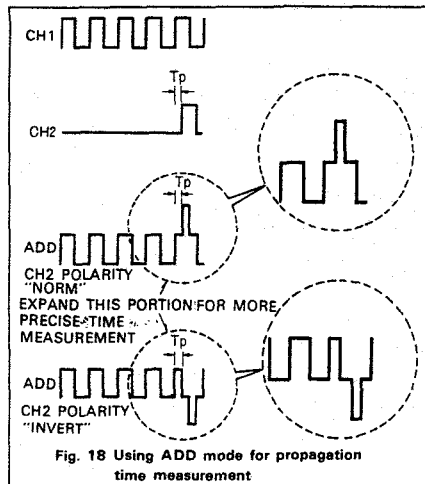

Fig. 18 Using ADD mode for propagation time measurement

Distortion Measurement:

An amplifier stage, or an entire amplifier unit, may be measured for distortion with this oscilloscope. This type of measurement is especially variable when the slope of a waveform must be faithfully reproduced by an amplifier. Fig. 19 shows the testing of such a circuit using a triangular wave, such as is typically encountered in the recovered audio output of limiting circuit which precedes the modulator of transmitter. The measurement may be made using any type of signal; merely use the type of signal for testing that is normally applied to the amplifier during normal operation. The procedure for distortion testing follows:

1. Apply the type of signal normally encountered in the amplifier under test.
2. Connect CH1 probe to the input of the amplifier and CH2 probe to the output of the amplifier. It is preferable if the two signals are not inverted in relationships to each other, but inverted signals can be used.
3. Set CH1 and CH2 AC-GND-DC switches to AC.
4. Set MODE switch to DUAL and NORM-CHOP button to NORM.
5. Set sync SOURCE switch to CH1 and adjust controls as described in waveform viewing procedure for synchronized waveforms.
6. Adjust CH1 and CH2 POSITION controls to superimpose the waveforms directly over each other.
7. Adjust CH1 and CH2 vertical sensitivity controls (VOLTS/DIV and VARIABLE) so that the waveforms are as large as possible without exceeding the limits of the scale, and so that both waveforms are exactly the same height.
8. Now, set the MODE switch to ADD position and pull CH2 POLARITY switch (if one waveform is inverted in relationships to the other, use normal CH2 polarity).

Adjust the fine vertical sensitivity control (CH2 VARIABLE) slightly for the minimum remaining waveform. Any waveform that remains equals distortion; if the two waveforms are exactly the same amplitude and there is no distortion, the waveforms will cancel and there will be only a straight horizontal line remaining on the screen.

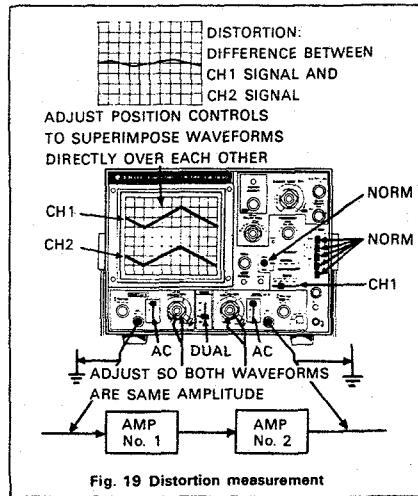

Fig. 19 Distortion measurement

Gated Ringing Circuit (burst circuit):

The circuit and waveform of Fig. 20 are shown to demonstrate the type of circuit in which the dual-trace oscilloscope is effective both in design and troubleshooting applications.

Fig. 20 shows a burst circuit. The basic oscilloscope control settings are identical to those of in Fig. 16.

Waveform EA is the reference waveform and is applied to CH2 input. All other waveforms are

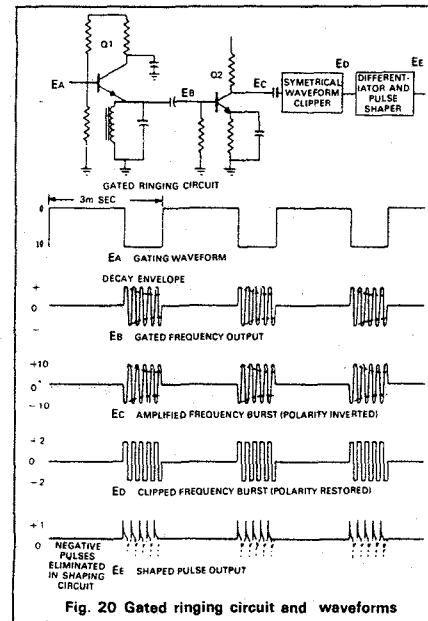

Fig. 20 Gated ringing circuit and waveforms

sampled at CH1 and compared to the reference waveform of CH2. The frequency burst signal can be examined more closely either by increasing the sweep time per division to 0.5 ms per division or by pulling out on the \leftarrow position control to obtain 5 times magnification. This control can then be rotated as desired to center the desired waveform information on the oscilloscope screen.

Delay Line Test:

The dual-trace feature of the oscilloscope can also be used to determine the delay times of transmission type delay line as well as ultrasonic type delay lines. The input pulse can be used to trigger or synchronize the CH 1 display and the delay line output can be observed on CH2. A respective type pulse will make it possible to synchronize the displays. The interval between repetitive pulses should be large compared to the delay time to be investigated. In addition to determining delay time, the pulse distortion inherent in the delay line can be determined by examination of the delay pulse observed on CH2 display.

Fig. 21 shows the typical oscilloscope settings as well as the basic test circuit. Typical input and output waveforms are shown on the oscilloscope display.

Any pulse stretching and ripple can be observed and evaluated. The results of modifying the input and output terminations can be observed directly. A common application of the delay line checks is found in color television receivers to check the "Y" delay line employed in the video amplifier section. The input waveform and the output waveform are compared for delay time, using the horizontal sync pulse of the composite video signal for reference. The delay is approximately one microsecond. In addition to determining the delay characteristics of the line, the output waveform reveals any distortion that may be introduced from an impedance mismatch or greatly attenuated output resulting from an open line.

Stereo Amplifier Servicing:

Another convenient use for a dual-trace oscilloscope is in troubleshooting stereo amplifiers. If identical amplifiers are used and the output of one is weak, distorted or otherwise abnormal, the dual-trace oscilloscope can be efficiently used to localize the defective state. With an identical signal applied to the inputs of both amplifiers, a side-by-side comparison of both units can be made by progressively sampling identical signal points in both amplifiers. When the defective or malfunctioning stage has been located, the effects of whatever trouble-

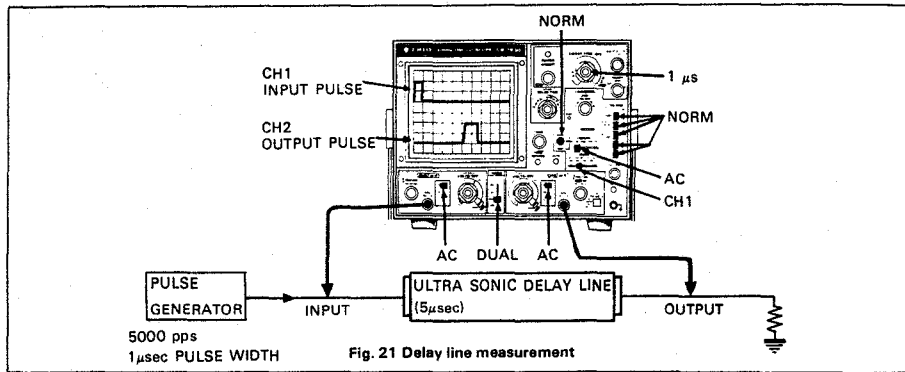

Fig. 21 Delay line measurement

shooting and repair methods are employed can be observed and analyzed immediately.

Amplifier Phase Shift Measurements:

Phase measurements can be made by several methods using oscilloscopes. Typical applications are in circuits designed to produce a specific phase shift, and measurement of phase shift distortion in audio amplifiers and networks.

In all amplifiers, a phase shift is always associated with a change in amplitude response. For example, at the -3 dB response points, a phase shift of 45° occurs. Phase measurements can be performed by operating the oscilloscope either in the dual-trace mode or the X-Y mode. This method uses the dual-trace mode to measure amplifier phase shift directly. Fig. 22 illustrates this method. In this particular case, the measurements are being made at approximately 5000 Hz. The input signal to the audio amplifier is used as a reference and is applied to the CH1 input jack.

The sweep time VARIABLE control is adjusted as required to provide a complete cycle of the input waveform display on 8 div horizontally. A waveform height of 2 div is used. The 8 div display represents 360° at the displayed frequency and each division represents 45° of the waveform. The vertical attenuator controls of CH2 are adjusted as required to produce a peak-to-peak waveform amplitude of 2 div as shown in Fig. 22. The CH2 POSITION control is adjusted so that the CH2 waveform is displayed on the same horizontal axis as the CH1 waveform as shown in Fig. 22. The distance between corresponding points on the horizontal axis for the two waveforms then represents the zero crossover points of the two waveforms are compared. It is shown that a difference of 1 div. exists. This is then interpreted as a phase shift of 45° .

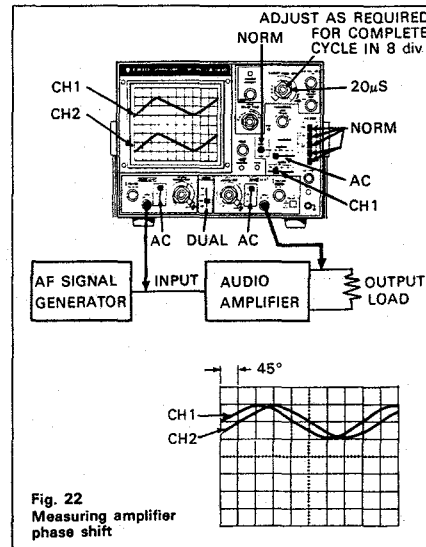

Fig. 22 Measuring amplifier phase shift

Television Servicing:

Many of the television servicing procedures can be performed using single-trace operation. These are outlined later in the applications section covering single-trace operations. One of these procedures, viewing the VITS (vertical interval test signal), can be accomplished much more effectively using a dual-trace oscilloscope. As outlined in the single-trace applications section and as shown in Fig. 23, the information on the Field 1 and Field 2 vertical blanking interval pulse is different. This is shown in detail in Fig. 23. Also, because the oscilloscope sweep is synchronized to the vertical blanking interval waveform, the Field 1 and Field 2 waveforms are superimposed onto each other.

With dual-trace operation, the signal information on each blanking pulse can be viewed separately without overlapping. Fig. 25 indicates the oscilloscope control setting for viewing the alternate VITS.

Most network television signals contain a built-in test signal (the VITS) that can be a very valuable tool in troubleshooting and servicing television sets. This VITS can localize trouble to the antenna, tuner, IF or video sections and shows when realignment may be required. The following procedures show how to analyze and interpret oscilloscope displays of the VITS.

The VITS is transmitted during the vertical blanking interval. On the television set, it can be seen as a bright white line above the top of the picture, when the vertical linearity or height is adjusted to view

the vertical blanking interval (on TV sets with internal retrace blanking circuits, the blanking circuit must be disabled to see the VITS).

The transmitted VITS is precision sequence of a specific frequencies, amplitudes and waveshapes as shown in Fig. 23.

Television networks use the precision signals for adjustment and checking of network transmission equipment, but the technician can use them to evaluate television multiburst signal in VITS can also be set performance.

The first frame of VITS at the "B" section (line 18) in Fig.23 begins with a white reference signal, followed by sine wave frequencies of 0.5 MHz, 1.0 MHz, 2 MHz, 3 MHz, 4.0 MHz and 3.58 MHz. This sequence of frequencies is called the "multi-burst".

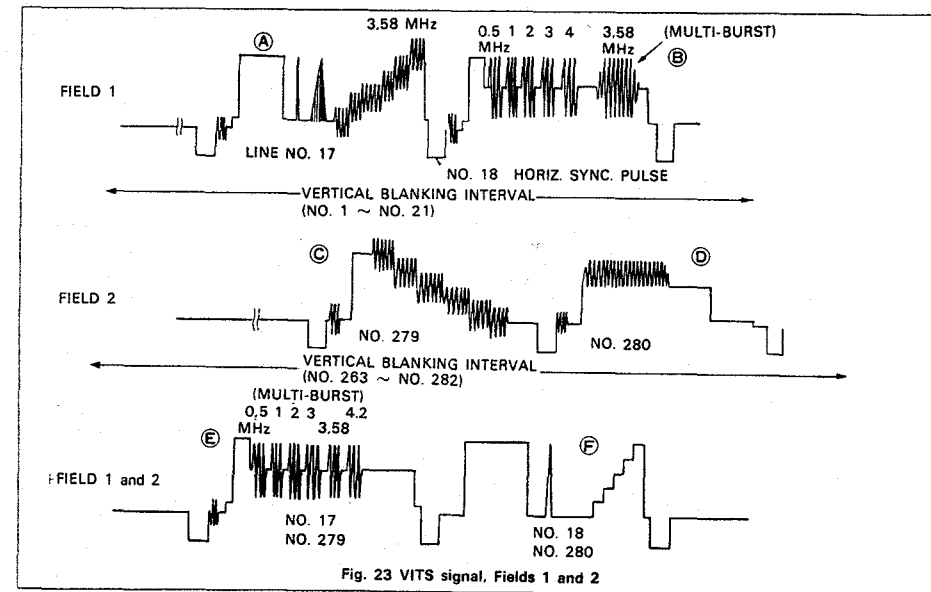

Fig. 23 VITS signal, Fields 1 and 2

This multi-burst portion of the VITS is the portion that can be most valuable to the technician. The second line of Field 1 and the second line of Field 2 (lines 18 and 280) may contain the sine-squared pulse, window pulse and the staircase of 3.58 MHz bursts at progressively lighter shading. These are valuable to the network, but have less value to the technician. As seen on the television screen, Field 1 is interlaced with Field 2 so that line 17 is followed by line 279 and line 18 is followed by line 280. The entire VITS appears at the bottom of the vertical blanking pulse and just before the first line of video.

Now to analyze the waveform. All frequencies of

the multi-burst are transmitted at the same level, but should not be equally coupled through the receiver due to its response curve. Fig. 24 shows the desired response for a good color television receiver, identifying each frequency of the multi-burst and showing the allowable amount of attenuation for each. Remember that -6 dB equals half the reference voltage (the 2.0 MHz modulation should be used for reference).

To localize trouble, start by observing the VITS at the video detector. This will localize trouble to a point either before or after the detector. If the multi-burst is normal at the detector, check the VITS on other channels. If some channels look

okay but others do not, you probably have tuner or antenna-system troubles. Don't overlook the chance of the antenna system causing "holes" or tilted response on some channels. If the VITS is abnormal at the video detector on all channels, the trouble is probably in the IF amplifier stages.

As another example, let us assume that we have a set on the bench with a very poor picture. Our oscilloscope shows the VITS at the video detector to be about normal except that the burst at 2.0 MHz is low compared to the bursts on either side. This suggests an IF trap is detuned into the passband, chopping out frequencies about 2 MHz below the picture carrier frequency. Switch to another channel carrying VITS. If the same thing is seen, then our reasoning is right, and the IF amplifier requires realignment.

If the poor response at 2 MHz is not seen on other channels, may be an FM trap at the tuner input is misadjusted, causing a bite on only one channel. Other traps at the input of the set could similarly be misadjusted or faulty.

If the VITS response at the detector output is normal for all channels, the trouble will be in the video amplifier.

Look for open peaking coils, off-value resistors, solder bridges across foil patterns, etc.

With dual-trace oscilloscope operation, the signal information on each vertical blanking interval can be viewed separately without trace overlapping, although the information alternates with each field. Fig. 25 indicates the oscilloscope control setting for viewing the alternate vertical blanking intervals.

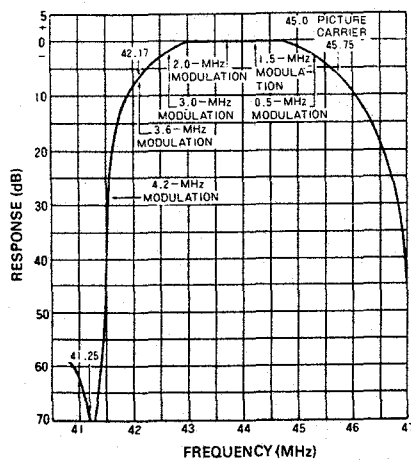

Fig. 24 Color TV IF amplifier response curve

- The color TV-receiver on which the vertical interval information is to be viewed must be set to a station transmitting a color broadcast.
- The control settings of Fig. 25 are these required to obtain a 2-field vertical display on CH1.
- With the oscilloscope and the TV receiver into operating, connect the CH1 probe (set to 10 : 1) to video detector test point.
- Set the SLOPE switch as follows:
 - If the sync and blanking pulses of the observed video signal are positive, use SLOPE +.
 - If the sync and blanking pulses are negative, use SLOPE -.
- Adjust the sweep time VARIABLE control so that 2 vertical fields are displayed on the oscilloscope screen.
- Connect the CH2 probe (set to 10 : 1) to the video detector test point.
- Set the MODE switch to DUAL position.
- Place the sweep time VARIABLE in the CAL position.
- Set the SWEEP TIME/DIV control to the 0.1 ms/div position. This expands the display by increasing the sweep speed. The VITS information will appear toward the right hand portion of the expanded waveform displays. The waveform information on each trace may appear as shown in Fig. 23.
- Because there is no provision for synchronizing the oscilloscope display to either of the two fields which comprise a complete vertical frame, it cannot be predicted which field display will appear on the CH1 or CH2 display.
- With the delay sweep applied (see page 13), adjust VITS signals as shown in Fig. 23.
- Once the CH1 and CH2 displays have been identified as being either Field 1 or Field 2 VITS information, the probe corresponding to the waveform display which is to be used for signal-tracing and troubleshooting can be used, and the remaining probe should be left at the video detector test point to insure that the sync signal is not interrupted. If the sync signal is interrupted, the waveform displays may be reversed because, as previously explained, there is no provision in the oscilloscope to identify either of the two vertical fields which comprise a complete frame.
- Depending on sweep time setting, the odd- and even-numbered fields may be visually overlapped. In such a case, adjust the HOLD OFF control to separate each field.

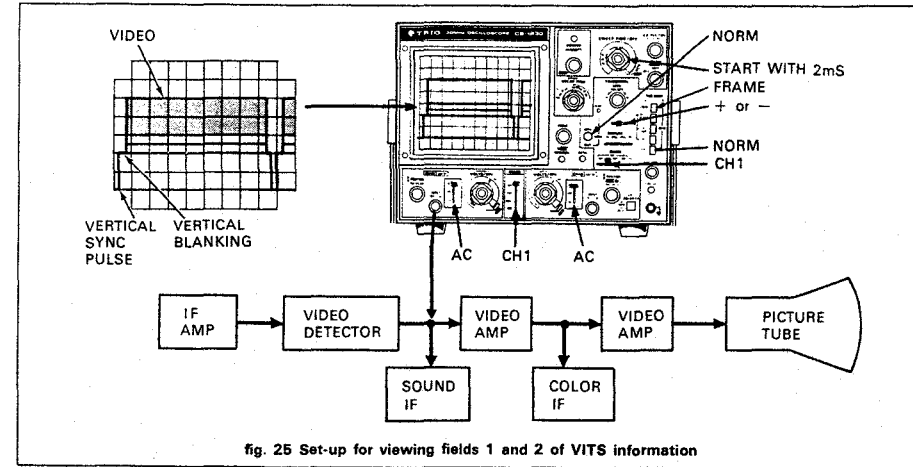

Fig. 25 Set-up for viewing fields 1 and 2 of VITS information

SINGLE-TRACE APPLICATIONS

Introduction:

In addition to the dual-trace applications previously outlined, there are, of course, many servicing and laboratory applications where only single-trace operation of the oscilloscope is required.

Single-trace Operation and Peak-to-peak Voltage Readings:

For general troubleshooting and isolation of troubles in television receivers, the oscilloscope is an indispensable instrument. It provides a visual display of the absence or presence of normal signals.

This method (signal-tracing) may be used to trace a signal by measuring several points in the signal path. As measurements proceed along the signal path, a point may be found where the signal disappears. When this happens, the source of trouble has been located.

However, the oscilloscope shows much more than the mere presence or absence of signals. It provides a peak-to-peak voltage measurement. The schematic diagram or accompanying service data on the equipment being serviced usually includes waveform picture. These waveform picture include the required sweep time and the normal peak-to-peak voltage. Compare the peak-to-peak voltage readings on the oscilloscope with those shown on the waveform picture. Any abnormal readings should be followed by additional readings in the suspected circuits until the trouble is isolated to as small an area as possible.

Composite Video Waveform Analysis:

Probably the most important waveform in television servicing is the composite waveform consisting of the video signal, the blanking pedestals signal and the sync pulses. Fig. 26 and Fig. 27 show typical oscilloscope traces when observing composite video signals synchronized with horizontal sync pulses and vertical blanking pulses.

Composite video signals can be observed at various stages of the television receiver to determine whether circuits are performing normally. Knowledge of waveform makeup, the appearance of a normal waveform, and the causes of various abnormal waveforms help the technician locate and correct many problems. The technician should study such waveforms in a television receiver known to be in good operating condition, noting the waveform at various points in the video amplifier.

To set up the oscilloscope for viewing composite video waveforms, use the following procedures:

- Tune the television set to a local channel.
- Set the MODE switch to CH2 position.
- Set the SWEEP TIME/DIV switch to the 10 μ s/div position for observing TV horizontal lines or to the 2ms/div position for observing TV vertical frames.
- For horizontal line, set LINE/FRAME switch to LINE. For vertical frame, set the switch to FRAME.
- Set the SOURCE switch to the CH2 position.
- Pull the TRIGGERING LEVEL control to the AUTO position.

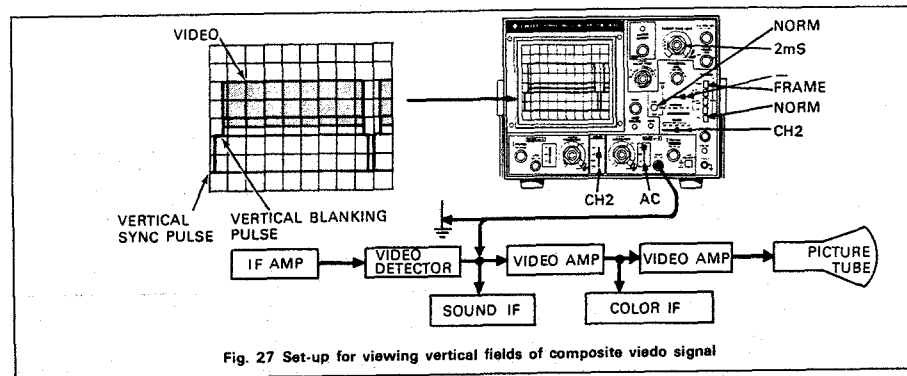
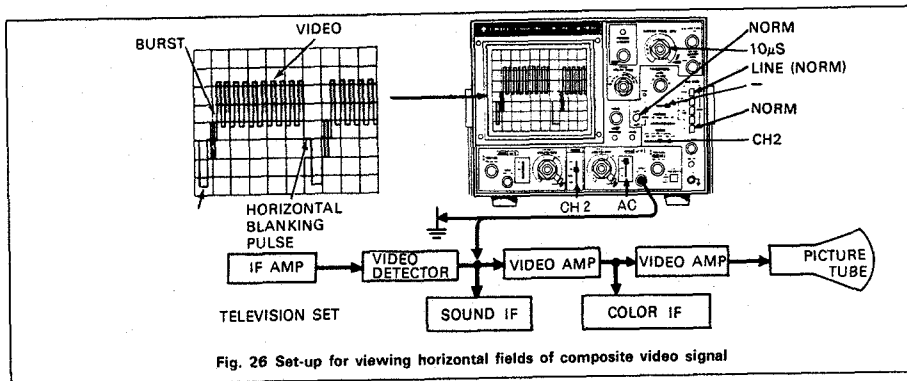

7. Set the CH2 AC-GND-DC switch to the AC position.
8. Connect a probe cable to the CH2 INPUT jack. Connect the ground clip of the probe to the television set chassis. With the probe set for 10 : 1 attenuation, connect the tip of the probe to the video detector output of the television set.
9. Set the CH2 VOLTS/DIV switch for the largest vertical deflection possible without going off-scale.
10. Rotate the TRIGGERING LEVEL control to a position that provides a synchronized display.
11. Adjust the sweep time VARIABLE for two horizontal lines or two vertical frames of composite video display.
12. If the sync and blanking pulses of the displayed video signals are positive, set the SLOPE switch to + ; if the sync and blanking pulses are negative, set the SLOPE switch to - .

13. Rotate the TRIGGERING LEVEL control to a position that provides a synchronized display.
14. Adjust the INTENSITY and FOCUS controls for the desired brightness and best focus.
15. To view a specific portion of the waveform, such as the color burst, using delay sweep (see page 13), enlarge the desired portion of the waveform.
16. Composite video waveforms may be checked at other points in the video circuits by moving the probe tip to those points and changing the VOLTS/DIV control setting as required to keep the display within the limits of scale and by readjusting the triggering LEVEL control to maintain stabilization. The polarity of the observed waveform may be reversed when moving from one monitoring point to another; therefore, it may be necessary to switch from slope + to slope - , or vice versa.

Sync Pulse Analysis:

The IF amplifier response of a television receiver can be evaluated to some extent by careful observation of the horizontal sync pulse waveform. The appearance of the sync pulse waveform is affected by the IF amplifier bandpass characteristics.

Some typical waveform symptoms and their relation to IF amplifier response are indicated in Fig. 28. Sync pulse waveform distortions produced by positive or negative limiting in IF overload conditions are shown in Fig. 29.

CIRCUIT DEFECT	HORIZONTAL PULSE DISTORTION	OVERALL RECEIVER FREQUENCY RESPONSE	EFFECT ON PICTURE
NORMAL CIRCUIT			PICTURE NORMAL
LOSS OF HIGH FREQUENCY RESPONSE			LOSS OF PICTURE DETAIL
EXCESSIVE HIGH FREQUENCY RESPONSE NON-LINEAR PHASE SHIFT			FINE VERTICAL BLACK & WHITE STRIATIONS FOLLOWING A SHARP CHANGE IN PICTURE SHADING
LOSS OF LOW FREQUENCY RESPONSE			CHANGE IN SHADING OF LARGE PICTURE AREAS, SMEARED PICTURE

Fig. 28 Analysis of sync pulse distortion

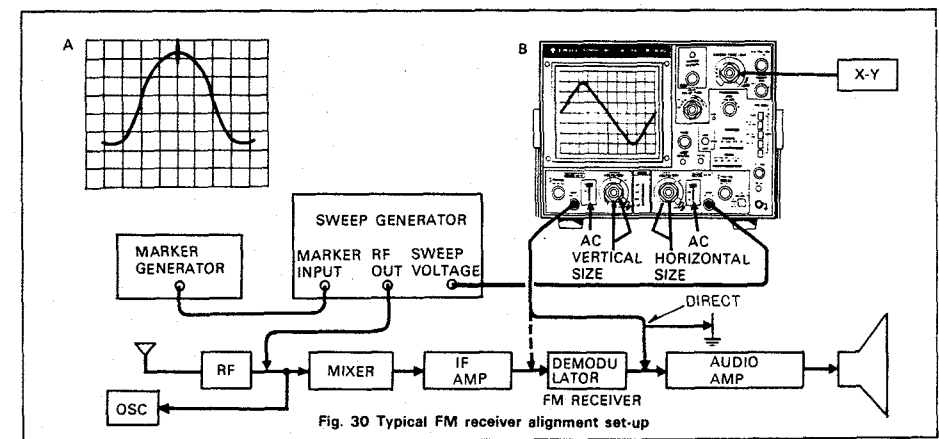
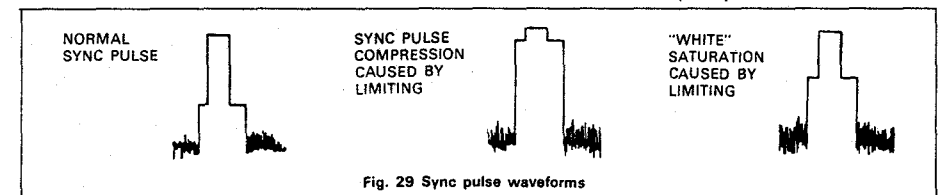

FM RECEIVER ADJUSTMENTS

1. Connect a sweep generator to the mixer input of the FM receiver. Set the sweep generator for a 10.7 MHz centered sweep.
2. Connect the sweep voltage output of the sweep generator to the CH2 input jack of the oscilloscope and set the oscilloscope controls for external horizontal sweep (SWEEP TIME/DIV to X-Y).
3. Connect the vertical input probe to the demodulator input of the FM receiver.
4. Adjust the oscilloscope vertical and horizontal gain controls for a display similar to that shown in Fig. 30A.
5. Set the marker generator precisely to 10.7 MHz. The marker "pip" should be in the center of the bandpass.
6. Align the IF amplifiers according to the manufacturer's specifications.
7. Move the probe to the demodulator output. The "S" curve should be displayed, and the 10.7 MHz "pip" should appear in the center (see Fig. 30B). Adjust the demodulator according to the manufacturer's instructions so the marker moves an equal distance from the center as the marker frequency is increased and decreased an equal amount from the 10.7 MHz center frequency.

X-Y APPLICATION

Phase Measurement:

Phase measurements may be made with an oscilloscope. Typical applications are in circuits designed to produce a specific phase shift, and measurement of phase shift distortion in audio amplifiers or other audio networks. Distortion due to non-linear amplification is also displayed in the oscilloscope waveform.

A sine wave input is applied to the audio circuit being tested. The same sine wave input is applied to the vertical input of the oscilloscope, and the output of the tested circuit is applied to the horizontal input of the oscilloscope. The amount of phase difference between the two signals can be calculated from the resulting Lissajous' waveform. To make phase measurements, use the following procedures (refer to Fig. 31).

1. Using an audio signal generator with a pure sinusoidal signal, apply a sine wave test signal to the audio network being tested.

2. Set the signal generator output for the normal operating level of the circuit being tested. If desired, the circuit's output may be observed on the oscilloscope. If the test circuit is overdriven, the sine wave display is clipped and the signal level must be reduced.
3. Connect the CH2 probe to the output of the test circuit.
4. Set the SWEEP TIME/DIV to X-Y.
5. Connect the CH1 probe to the input of the test circuit.
6. Adjust the CH1 and CH2 gain controls for a suitable viewing size.
7. Some typical results are shown in Fig. 32. If the two signals are in phase, the oscilloscope trace is a straight diagonal line. If the vertical and horizontal gain are properly adjusted, this line is at 45° angle. A 90° phase shift produces a circular oscilloscope pattern. Phase shift of less (or more) the 90° produces an elliptical Lissajous pattern. The amount of phase shift can be calculated from the oscilloscope traces as shown in Fig. 33.

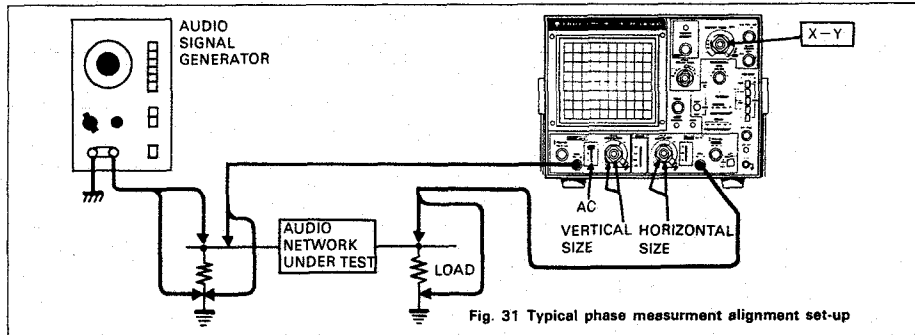

Fig. 31 Typical phase measurement alignment set-up

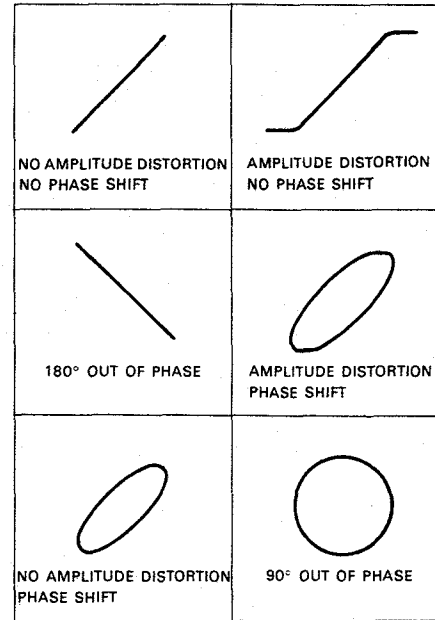

Fig. 32 Typical phase measurement oscilloscope displays

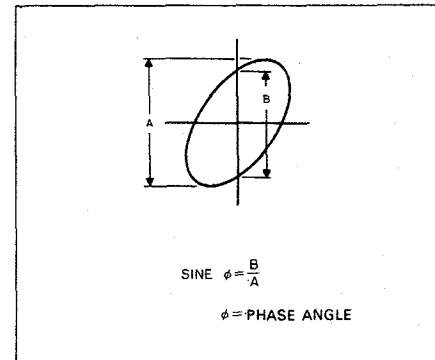

Fig. 33 Phase shift calculation

Frequency Measurement:

Procedure:

1. Connect the sine wave of known frequency to the CH2 input jack of the oscilloscope and set the SWEEP TIME/DIV control to X-Y. This provides external horizontal input.
2. Connect the vertical input probe (CH1 input) to the unknown frequency.
3. Adjust the channel 1 and 2 gain controls for a convenient, easy-to-read display.
4. The resulting pattern, shows the ratio between the two frequency. (see Fig. 34).

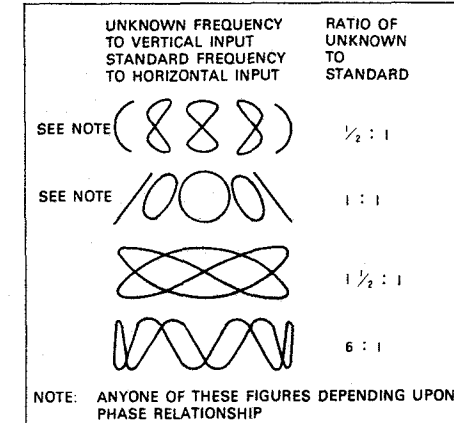
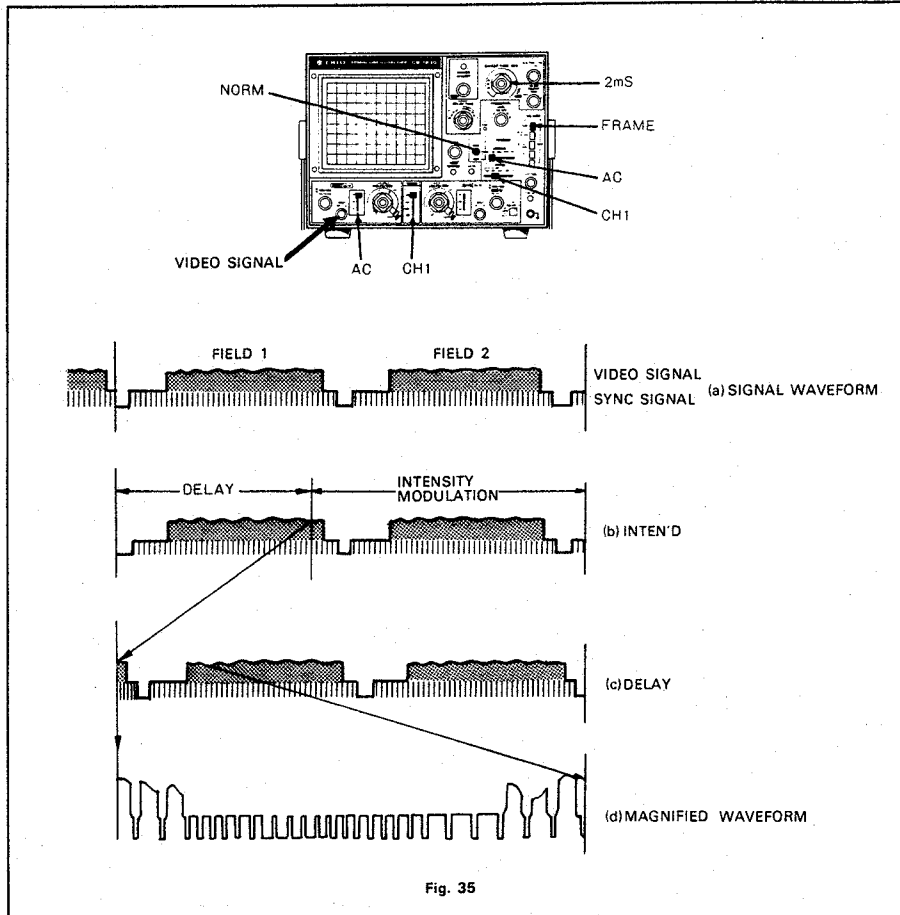

Fig. 34 Lissajous' waveforms used for frequency measurement

DELAY SWEEP APPLICATIONS

By use of delay sweep, video signal can be enlarged for easy observation, proceed as follows (Fig. 35):

1. Set the control knobs on the oscilloscope as shown in Fig. 35 to observe video signal (Fig. 35-a).
2. With INTEN'D depressed, adjust DELAY TIME and VARIABLE so that the left end of the intensity modulation reaches near the end of the field 1 (Fig. 35-b).
3. Press DELAY (CH1) and the oscilloscope is set in delay sweep mode while the waveform starting at the portion set by the intensity modulation is displayed (Fig. 35-c).
4. By adjusting SWEEP TIME/DIV, the waveform during vertical blanking time can be magnified for observation (Fig. 35-d).



PRECAUTIONS

1. Avoid using the oscilloscope in a location exposed to direct sunlight.
2. Select a place free from high temperature and humidity. Do not use the oscilloscope in a dusty location.
3. Do not operate the oscilloscope in a place where mechanical vibrations are excessive or a place near equipment which generates strong magnetic fields or impulse voltages.
4. This oscilloscope is factory set for AC 240V operation. For AC 100V, 117V or 220V operation, change the position of the plug of the voltage selector at the rear panel as indicated by the arrow. When the oscilloscope is to be operated with AC 100V, 120V, be sure to replace the fuse with one rated at 0.7A.
5. Do not apply input voltages exceeding their maximum ratings. The input voltage to the vertical amplifier is up to 300V (DC + AC peak), the input for EXT. TRIG is up to 50V

6. Do not increase the brightness of the CRT unnecessarily.
7. Do not leave the oscilloscope for a long period with bright spot displayed on CRT. Reduce the brightness and soften the focus.
8. For X-Y operation, use the PULL X5 MAG switch in the PUSH position. If it is set in the PULL position, noise may appear in the waveform.
9. Setting the oscilloscope
The oscilloscope is provided with a handle which can be fixed at 22.5° angle intervals, permitting it to be set either vertically, horizontally or aslant.
Do not place any object on the oscilloscope or cover the ventilation holes of the case with a cloth or the like, as it will increase the temperature inside the case.

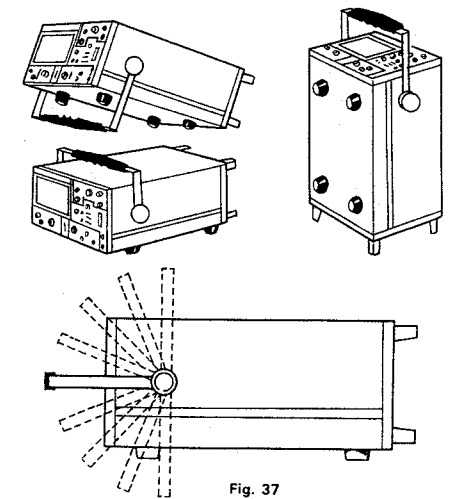
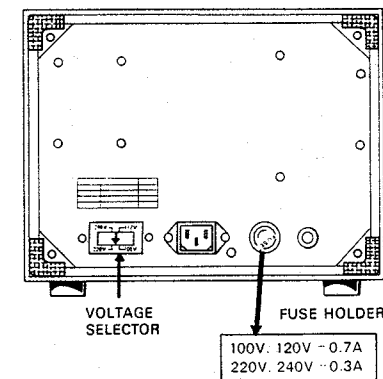

MAINTENANCE AND ADJUSTMENT

MAINTENANCE

Removing the case:

1. Remove the seven screws from the top and side walls of the case, using a Phillips head screwdriver.

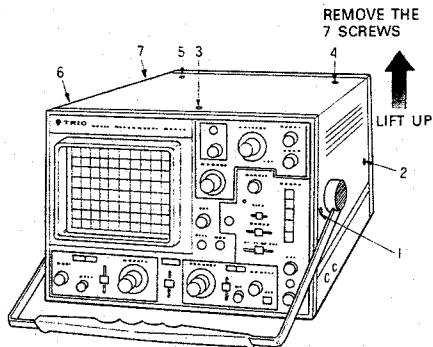

Fig. 38 Removing the top case

2. Hold the handle and lift up. The case is now ready for removal.
3. To remove the bottom plate, unscrew the four screws using a Phillips head screwdriver.

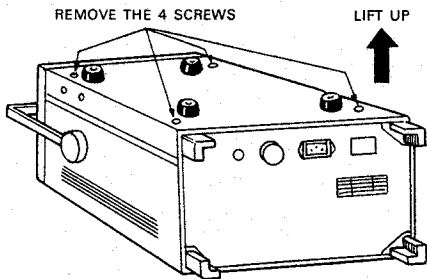

Fig. 39 Removing the bottom case

Caution: A high voltage (5000V) is present on the CRT socket. Before removing the case, be sure to turn off the power, and do not touch these parts with hand or a screwdriver even after the case has been removed.

ADJUSTMENT

Observe the following before making adjustments:

The oscilloscope is factory adjusted prior to shipment. If readjustment becomes necessary, the following points should be observed.

1. Check the power supply for correct voltage.
2. For adjustments, use a well insulated screwdriver.
3. Before marking adjustments, be sure to turn on the power and wait until the unit is stabilized.
4. For adjustments, follow the procedures described below.
5. If special test instruments are required for adjustments, contact Trio's service station.

Adjustment of Power Supply and CRT Circuits:

1. Adjustment of low power voltage
Measure the voltage at the No.8 pin of P306 and adjust VR304 for $+108V \pm 1\%$.
Next, measure the voltage on the pins 2 through 5 of P306 and on the pin 1 of P304 to check that these voltages are /8V, +5V, +15V, +10V and +120V, respectively. (Fig. 40)
2. Adjustment high tension voltage
Adjust VR303 so that the voltage on the pin 9 of P301 reaches $-1.5 kV \pm 1\%$ (CRT cathode voltage).
3. Intensity adjustment
With INTENSITY knob set in the 11 o'clock position, adjust VR302 until the trace disappears, then adjust TC301 so that the brightness at the sweep starting point is the same as the brightness at other points (SWEEP TIME/DIV in 0.2 μs position). Finally, adjust the spot with FOCUS and ASTIG. (Fig. 40)

Adjustments of CH1 Vertical Circuit:

Before making adjustments, set the knobs of oscilloscope as follows:

- MODE CH1 position
 - VOLTS/DIV 5 mV/div position
4. CRT Center Adjustment (Fig. 42)
With the test terminals P401 and P402 of the vertical main amplifier shorted, adjust VR402 until the trace comes in the center of CRT.
 5. VARIABLE ATT DC BAL Adjustment (Fig. 41)
Adjust VR101 so that the trace stays still at any position of VARIABLE of VOLTS/DIV.
 6. STEP ATT DC BAL Adjutment (Fig. 41)
Adjust VR103 so that the trace stays still at any position of VOLTS/DIV.
 7. POSITION Adjustment (Fig. 40)
With POSITION knob set in the mechanical center position, adjust VR105 until the trace is centered on CRT.
 8. Sensitivity Adjustment (Fig. 42)
With a calibrated 1 kHz 0.5V signal applied, adjust VR401 for 5 DIV deflection.

Adjustment of CH2 Vertical Circuit:

Before making adjustments, set the knobs of oscilloscope as follows:

- MODE CH2 position
- VOLTS/DIV 5 mV/div position

9. VARIABLE ATT DC BAL Adjustment (Fig. 41)
Adjust VR106 until the trace stays still at any position of VARIABLE of VOLTS/DIV.
10. STEP ATT DC BAL Adjustment (Fig. 41)
Adjust VR108 until the trace stays still at any position of VOLTS/DIV.
11. POSITION Adjustment
With POSITION knob set in the mechanical center position, adjust VR112 until the trace is centered on CRT. (Fig. 40)
12. Sensitivity Adjustment
With a calibrated 1 kHz 0.5V signal applied, adjust VR110 for 5 DIV deflection. (Fig. 40),

Horizontal Circuit Adjustment:

13. POSITION Adjustment (Fig. 43)
With POSITION knob set in the mechanical center position, adjust VR10 so that the start point of bright line is at the left end of the scale.
14. X POSITION Adjustment (Fig. 43)
With MODE set in X-Y and X axis (CH2) input in GND, adjust VR12 until the bright spot is centered on the screen.

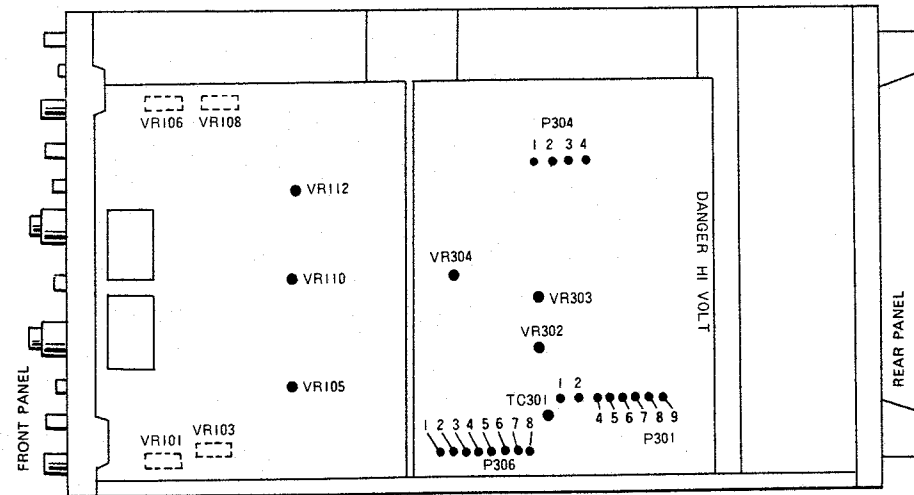

Fig. 40 Location of adjustments, bottom of scope

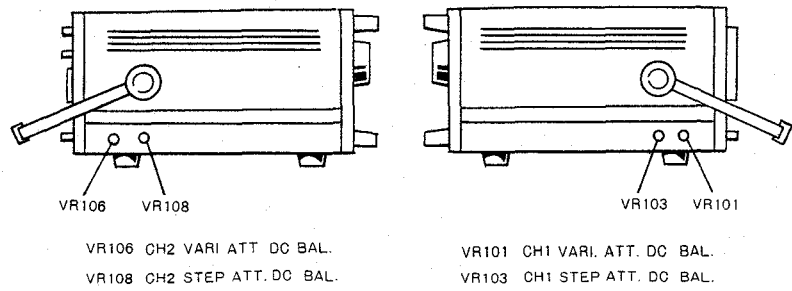

Fig. 41 Location of adjustments, right and left sides of scope

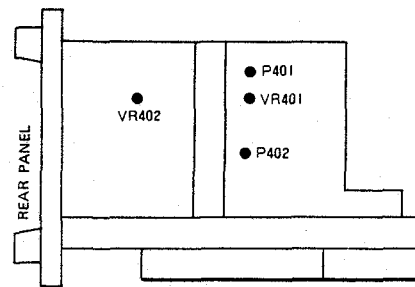

Fig. 42 Location of adjustment, left side of scope

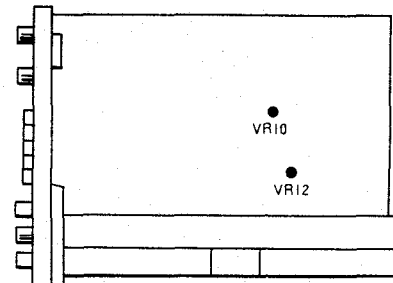
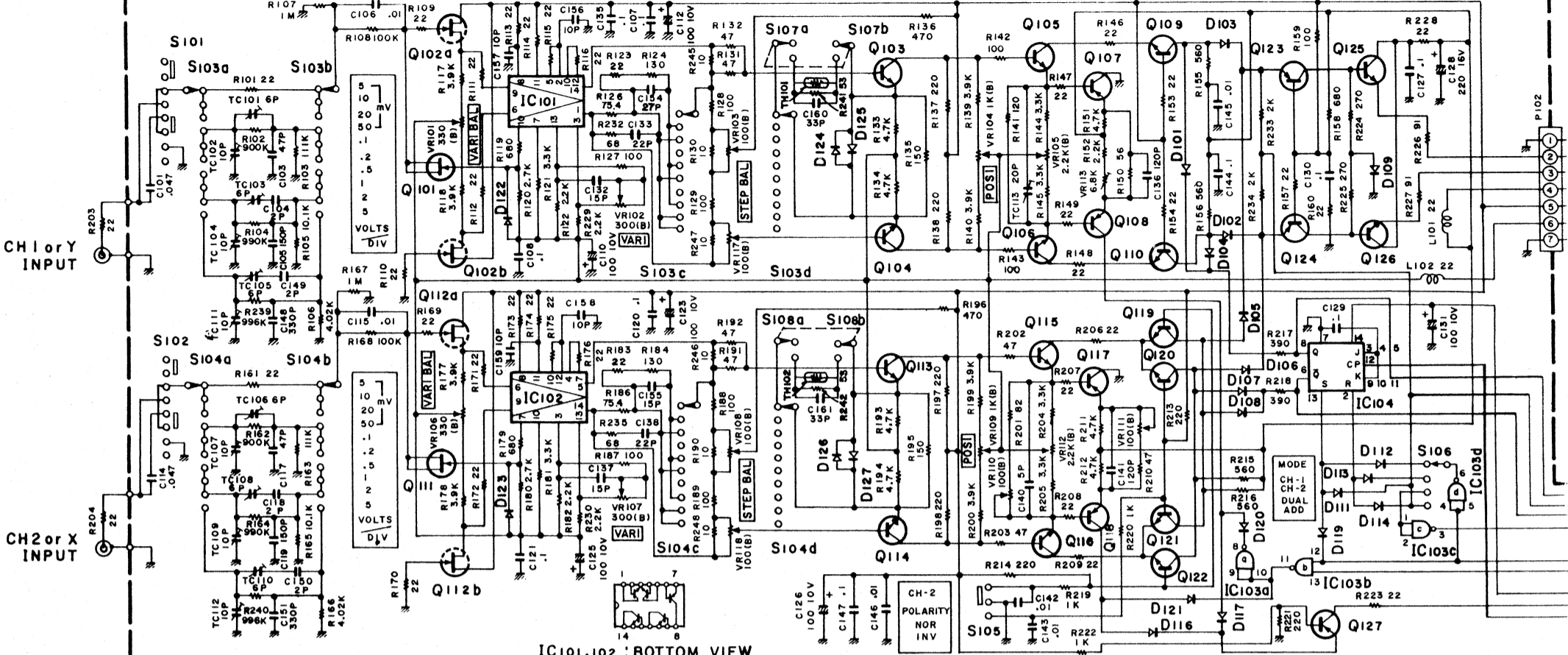

Fig. 43 Location of adjustments, right side of scope

VERTICAL AMP
(X73-1210-02)

Q 101,111 : 2SK30A(O) Q 102,112 : 28K228T-2B3 Q 103~106,109,110,113~116,119~122,125,126 : 2SC535(B) Q 107,108,117,118 : 2SA838(C) Q 123,124,127
D 101~108,122,123 : IS1587 D 109,111~114,116,117,119~121 : IS1555 D 124,127 : IN60 IC 101,102 : HA1127 IC 103 : TD3400 IC 104 : TD3472



SWEEP (X74-1190-00)

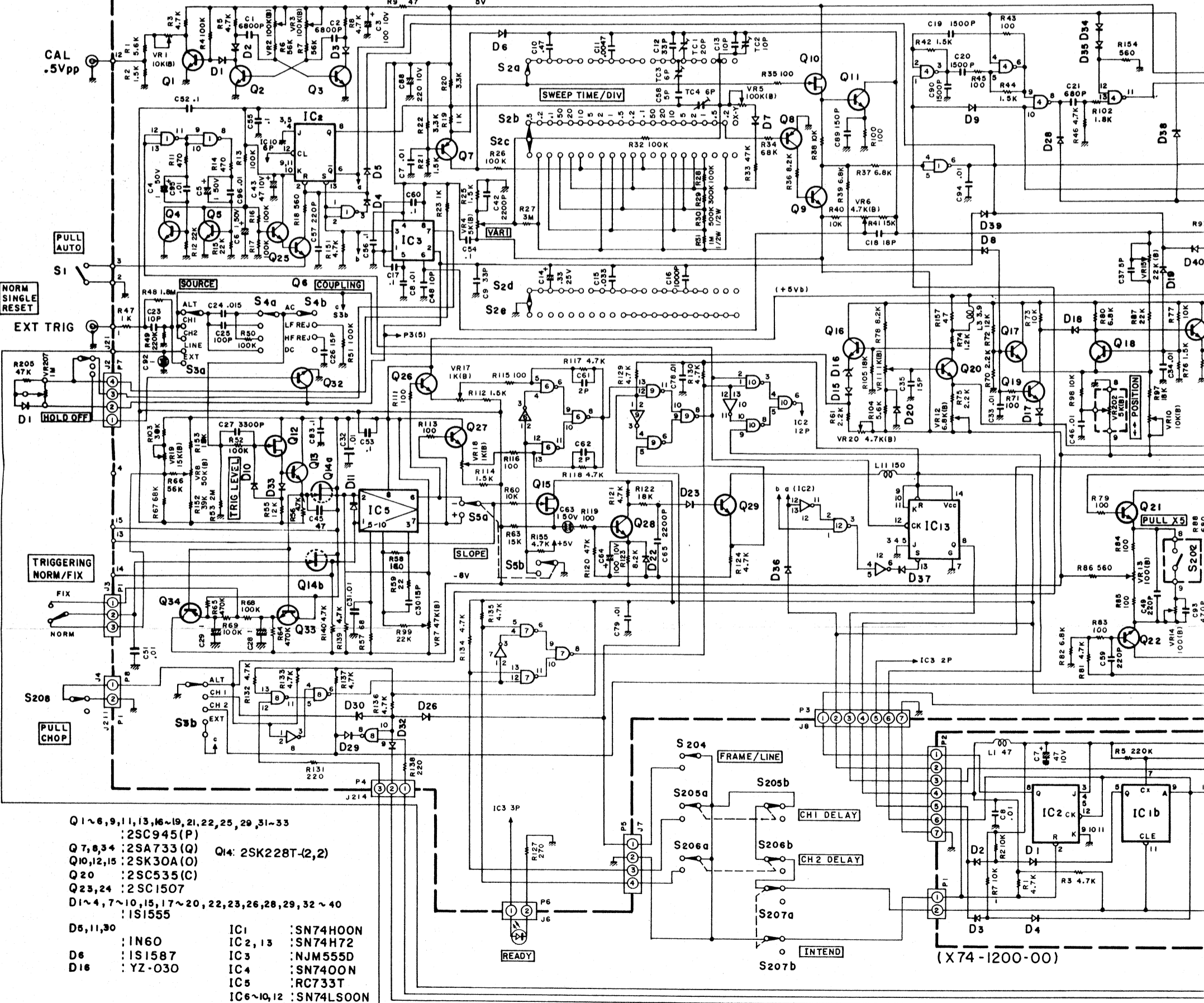

- Q 1~6, 9, 11, 13, 16~19, 21, 22, 25, 29, 31~33 : 2SC945(P)
- Q 7, 8, 34 : 2SA733(Q) Q 4 : 2SK228T-(2,2)
- Q 10, 12, 15 : 2SK30A(O) Q 14 : 2SK228T-(2,2)
- Q 20 : 2SC535(C)
- Q 23, 24 : 2SC1507
- D 1~4, 7~10, 15, 17~20, 22, 23, 26, 28, 29, 32~40 : IS1555
- D 5, 11, 30 : IN60 IC 1 : SN74H00N
- D 6 : IS1587 IC 2, 13 : SN74H72
- D 16 : YZ-030 IC 3 : NJM555D
- IC 4 : SN7400N
- IC 5 : RC733T
- IC 6~10, 12 : SN74LS00N

IATIC DIAGRAM

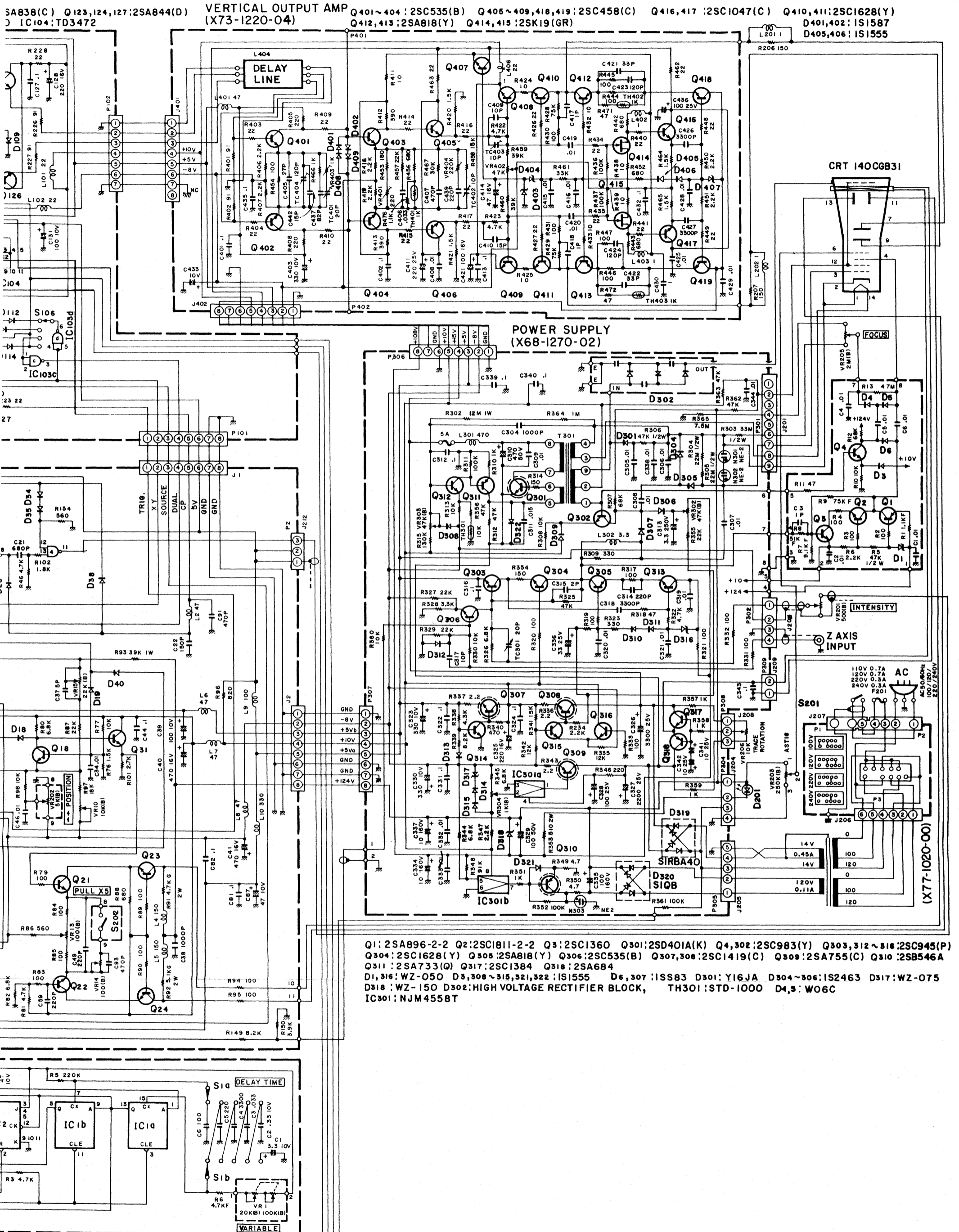

Q1: 2SA896-2-2 Q2: 2SC1811-2-2 Q3: 2SC1360 Q301: 2SD401A(K) Q4, 302: 2SC983(Y) Q303, 312 ~ 316: 2SC945(P)
 Q304: 2SC1628(Y) Q305: 2SA818(Y) Q306: 2SC535(B) Q307, 308: 2SC1419(C) Q309: 2SA755(C) Q310: 2SB546A
 Q311: 2SA733(Q) Q317: 2SC1384 Q318: 2SA684
 D1, 316: WZ-050 D3, 308 ~ 315, 321, 322: IS1555 D6, 307: ISS83 D301: Y16JA D304 ~ 306: IS2463 D317: WZ-075
 D318: WZ-150 D302: HIGH VOLTAGE RECTIFIER BLOCK, TH301: STD-1000 D4, 3: W06C
 IC301: NJM4558T