

MEDALIST  **SERIES**

MOO No 00058U
230V 3.2AMP
5/8" MAX CAP
HP = 3/4"
MADE = 1988
SER. NUM. 01960

DRILL PRESS INSTRUCTIONS

ATTENTION : READ INSTRUCTIONS BEFORE OPERATING DRILL PRESS

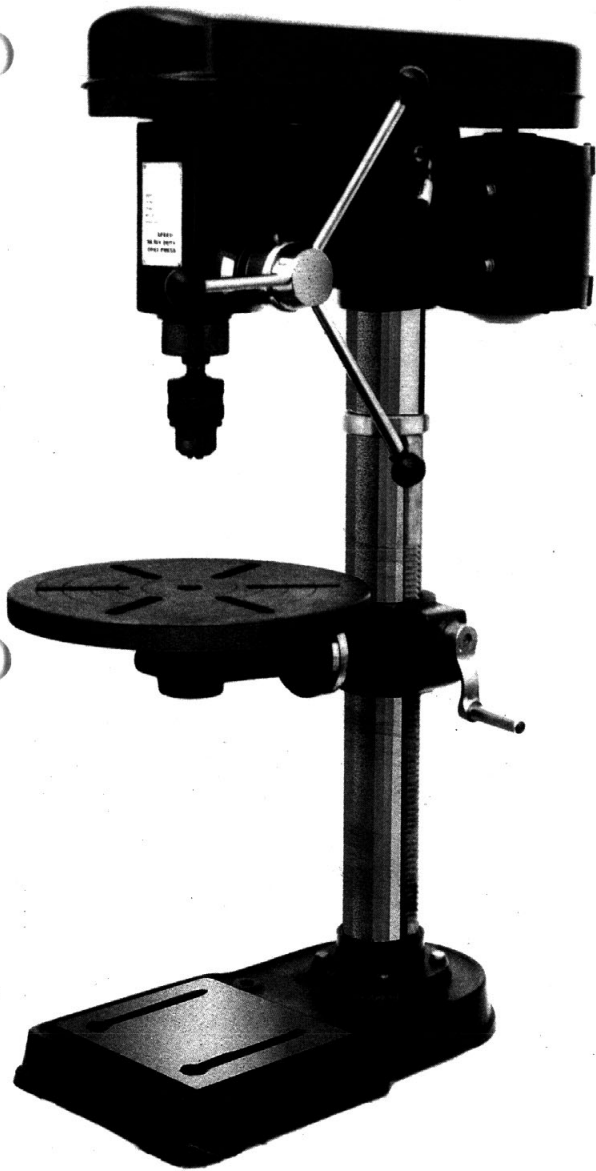

I. PARTS

Unpack carton, check your machine to see parts listed below:

A. Main Parts:

- | | |
|-----------------------------|--------|
| 1. Head assembly | 1 pc. |
| 2. Column with flange | 1 pc. |
| 3. Arm of table and bracket | 1 set. |
| 4. Table | 1 pc. |
| 5. Base | 1 pc. |

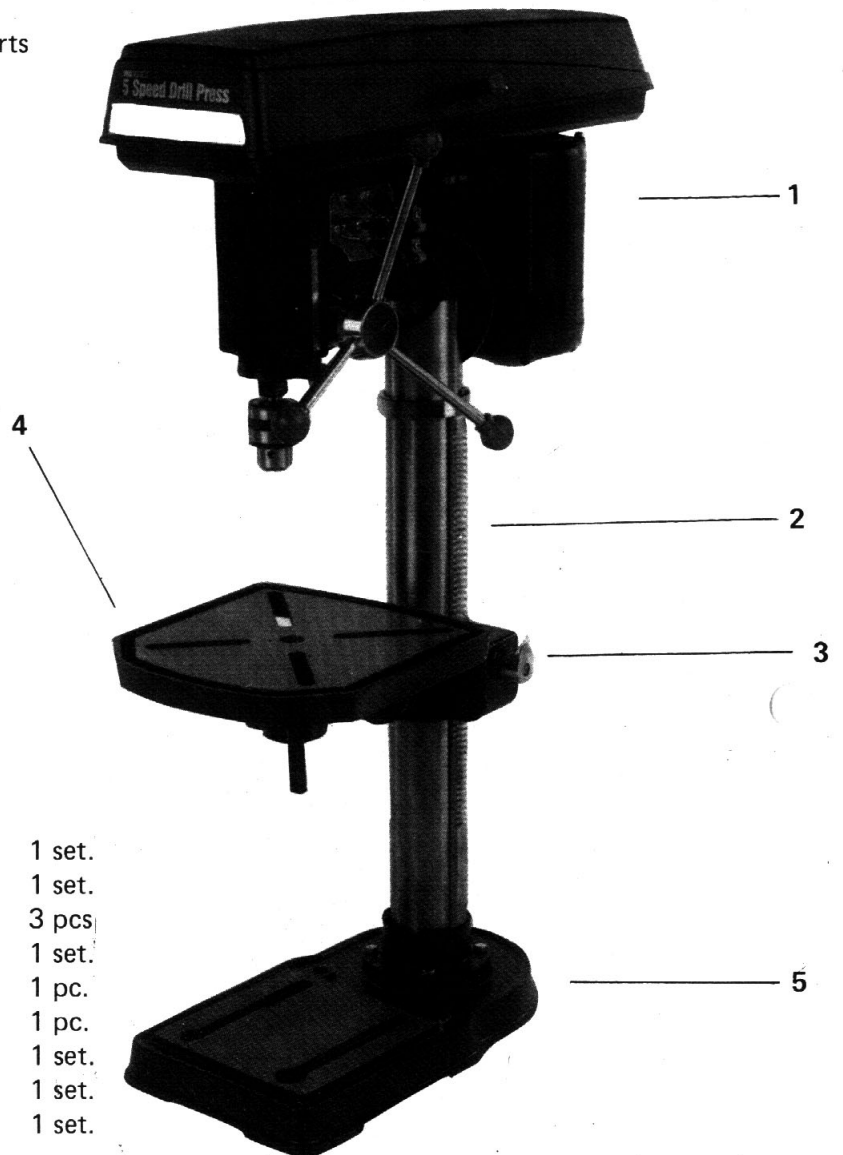

B. Accessories (in one separate box)

- | | |
|---|--------|
| 1. Chuck and key | 1 set. |
| 2. Arbor and wedge (for K-16(F)N only) | 1 set. |
| 3. Feeding handles and knobs | 3 pcs. |
| 4. Height adjusting handle, table bracket | 1 set. |
| 5. Clamp bolt, table bracket | 1 pc. |
| 6. Clamp bolt, table arm | 1 pc. |
| 7. Knob and screw, upper pulley cover | 1 set. |
| 8. Screws and washers, flange | 1 set. |
| 9. Allen wrenches (3mm, 5mm) | 1 set. |

Note: If you find any parts missing or damaged, contact the dealer for exchange or replacement

