

**OPERATORS
MANUAL
1966**

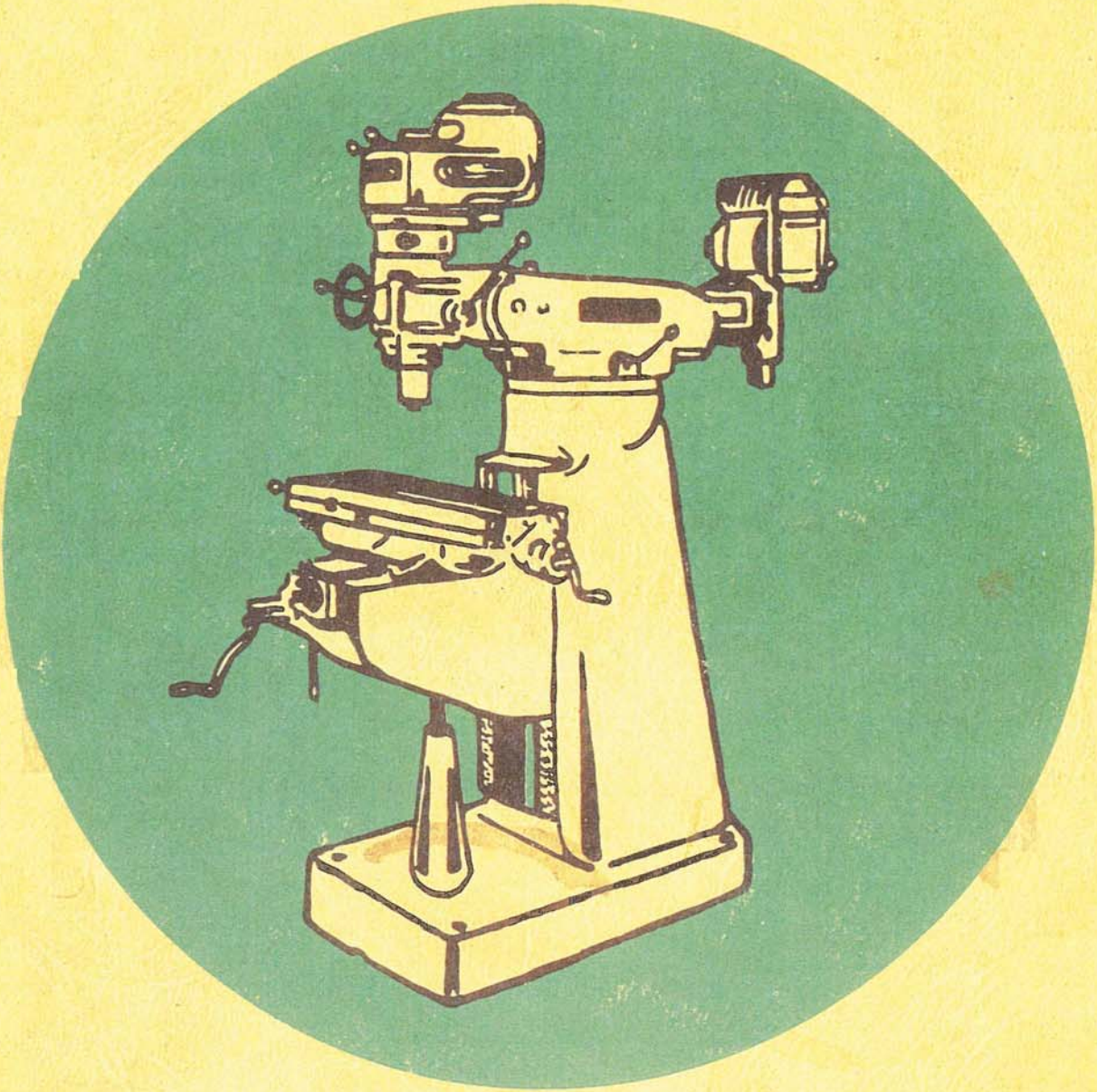

Bridgeport MACHINES, INC.

BRIDGEPORT, CONNECTICUT - U. S. A.

INDEX

	Page
Dimensional Drawing	1
Floor Plan	2
Long and Cross Feed Assembly	3
Uncrating	4
Shortages	4
Cleaning	4
Placing on Solid Foundation	4
Leveling Machines	4
Mounting Head on Overarm Adapter	5
Handles	5
Inspection	5
Alignment of Head	5
Lubrication	6
Lubrication Drawing	6
Adjustment of Table Gib	7
Adjustment of Saddle and Knee Gibs	7
Clamping Table, Saddle and Knee	8
Removing of Table	8
Removing of Saddle	8
Power Feed Attachment	9
Instructions for Installing Power Feed	9 & 10
Installation and Use of Measuring Attachment	11 & 12
Descriptive Photograph of Model "J" Attachment	13
Mounting Motor on Attachment	14
Placing and Adjusting Belts	14
Operating Instruction of "J" Attachment	14
Operating Instruction of "J" Attachment	15
Operating Instruction of "J" Attachment	16
Operating Instruction of "J" Attachment	17
General Speed Recommendations	18
Table of Cutting Speeds and Feeds	18
Parts Drawing on "J" Attachment	19
Parts List on "J" Attachment	20
Parts List and Drawing on BR Turret Milling Machine	21-22
Parts List and List on Power Feed Attachments	23
Parts Drawing and List on Model "M" Attachments	24
Parts Drawing and List on Shaping Attachment	25-26
Parts Drawing and List on Cherrying Attachment	27-28
Parts Drawing and List on Model "R" Attachment	29
Parts List and Drawing on Model "C" Attachment	30
Optical Measuring System	31
Optical Parts Drawing	32
Optical Parts List	33

Dimensional

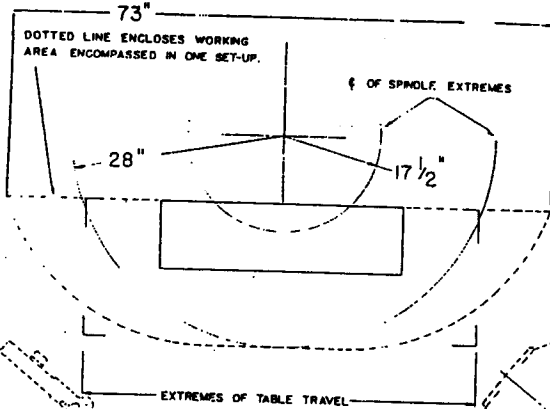
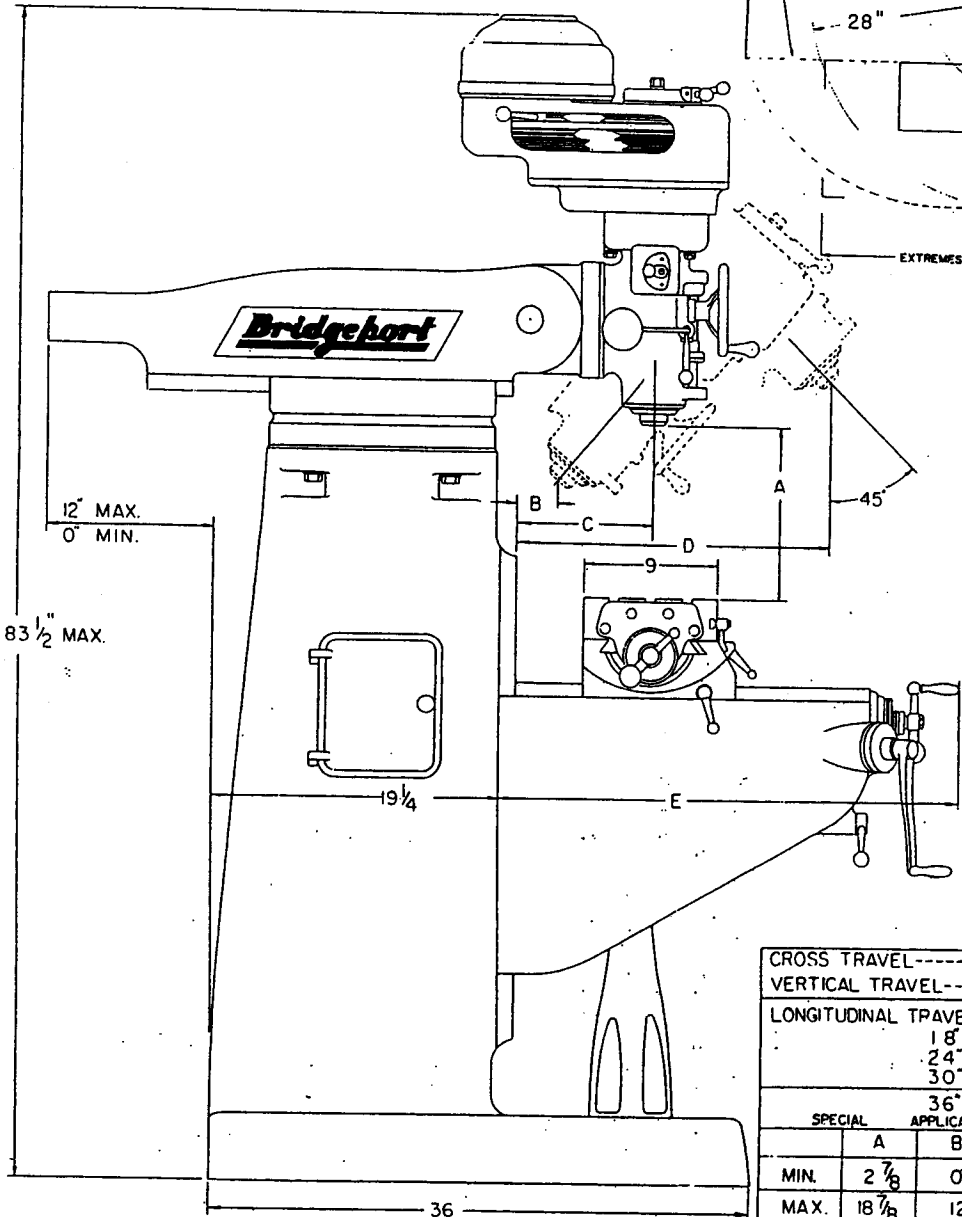

TURRET MILLER
with
MODEL "J" MILLING ATTACHMENT

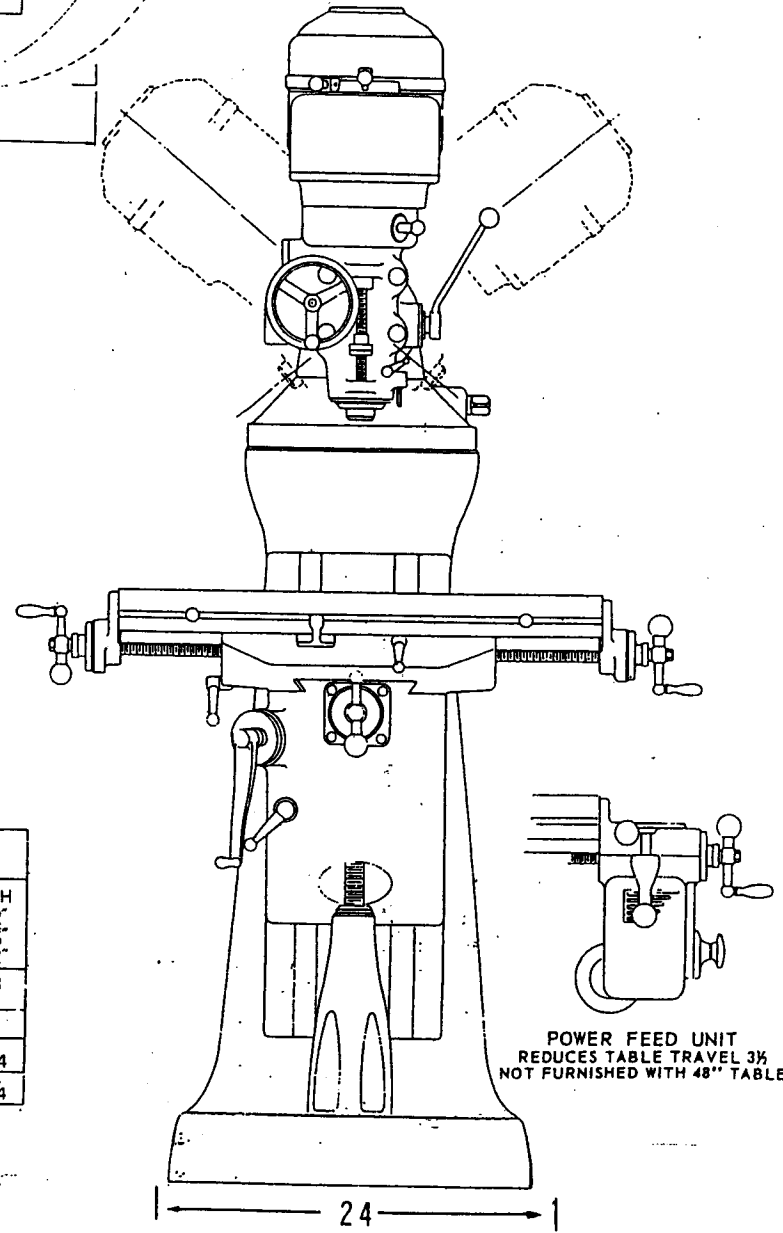

POWER FEED UNIT
REDUCES TABLE TRAVEL 3/4"
NOT FURNISHED WITH 48" TABLE

CROSS TRAVEL	-----12" OR 9"			
VERTICAL TRAVEL	-----16"			
LONGITUDINAL TRAVEL	TABLE LENGTH			
18"	32"			
24"	36"			
30"	42"			
	36" 48			
SPECIAL APPLICATIONS ONLY	A	B	C	D
MIN.	2 7/8	0	6 3/8	8 3/4
MAX.	18 7/8	12	18 3/8	20 3/4

	E
9" KNEE	27 1/2
12" KNEE	31 1/2

Drawing 2

Floor Plan

A

- 32" Table - 65½"
- 36" Table - 69½"
- 42" Table - 75½"
- 48" Table - 81½"

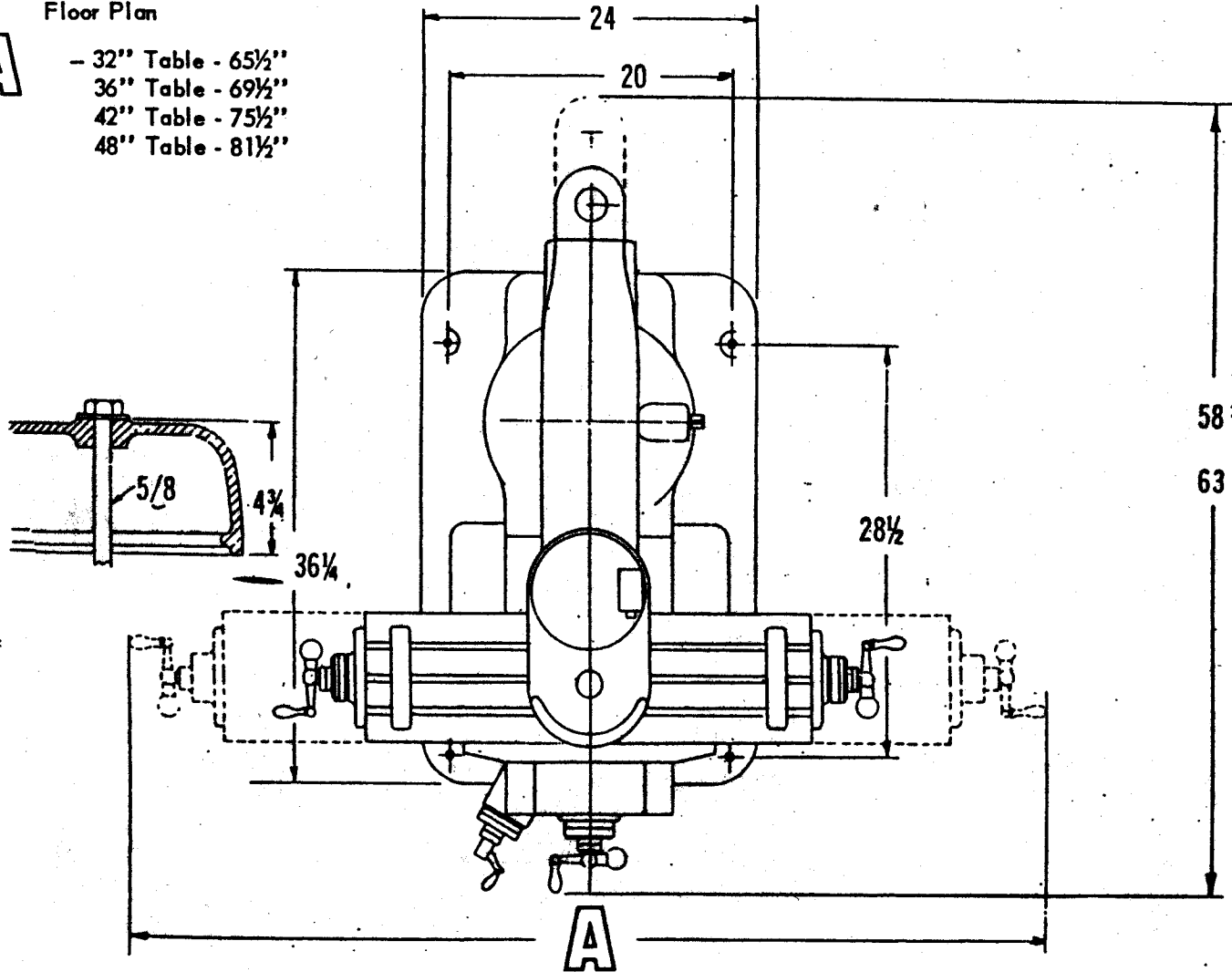

58¾ MOD. 9 BRJ

63 MOD. 12 BRJ

A

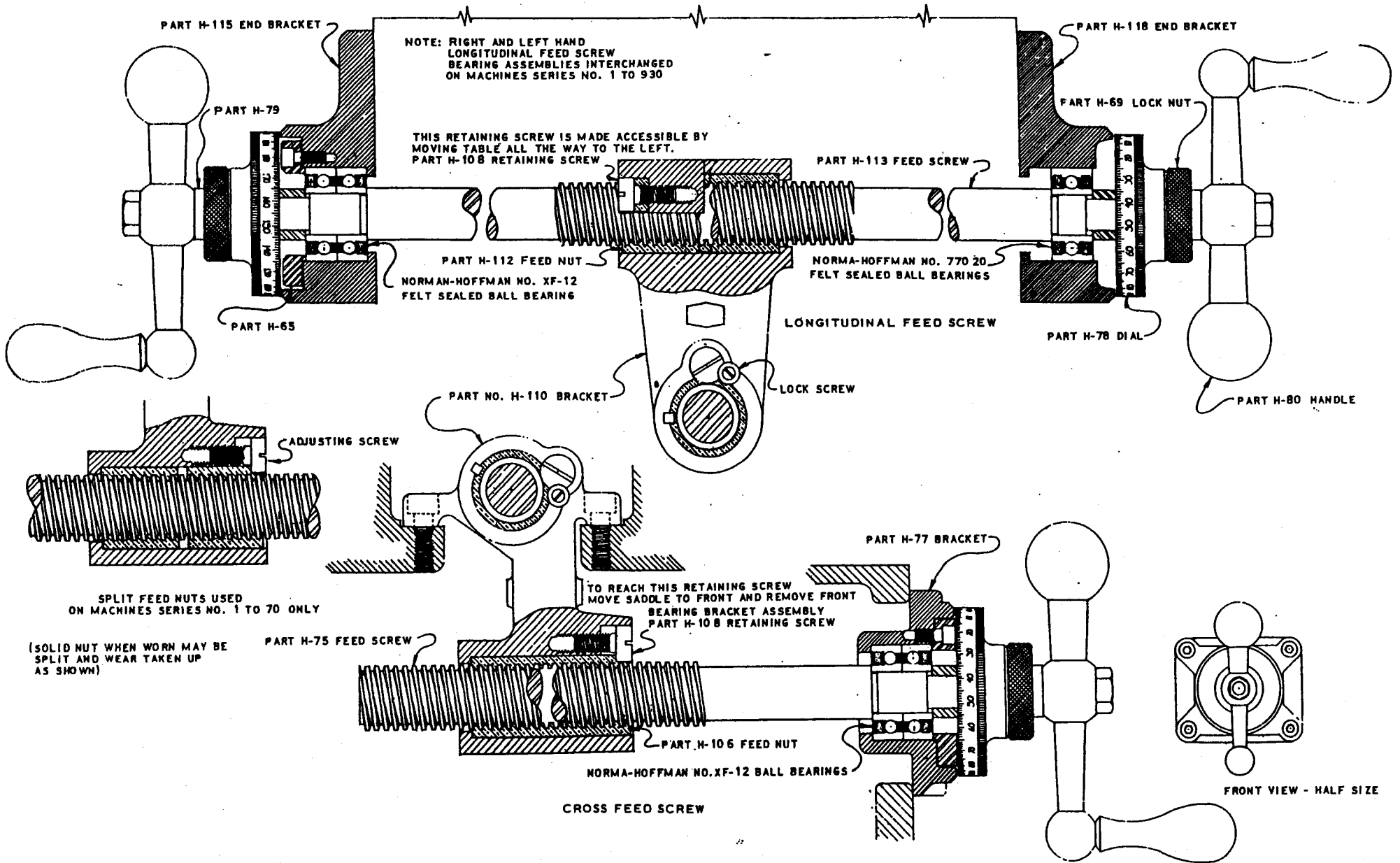

**LONGITUDINAL AND CROSS FEED ASSEMBLY,
BRIDGEPORT TURRET MILLING MACHINE**

Drawing 3

UNCRATING

Carefully remove protective crating and skids so that the machine and parts are not marred, scratched or impaired. In the event of damage in transit, communicate at once with our representative and the transportation company making delivery.

Machine should be lifted by placing a sling under overarm or by putting an eye bolt in tapped hole on top of overarm.

SHORTAGES

Check shipment carefully, against the itemized packing list which is included in the parts box. In case of shortages, report them immediately to the representative from whom the machine was purchased, indicating parts not received which have been checked on the packing list.

CLEANING

Thoroughly clean slush from machine with gasoline or kerosene. Do not move the table, saddle, knee or any movable part until all ways have been well cleaned and lubricated. Then, by hand, move table, saddle and knee to limit stop in one direction. Clean and lubricate exposed ways and then move each unit to the opposite limit stop and similarly clean and lubricate the exposed ways. Loosen bolts to unlock overarm, and move it forward and backward to the full length in order to clean and lubricate.

PLACING ON SOLID FOUNDATION

The column and base are cast in one piece. When setting machine on a concrete foundation, it is advisable to use a little grout (thin mortar) to take care of any unevenness in the concrete as well as to provide a solid foundation at all points.

When setting machine on a floor that has any surface irregularities, shims should be used to correct this condition to the greatest extent possible.

LEVELING MACHINES

Set machines by leveling the work table lengthwise and crosswise with a precision instrument.

MOUNTING HEAD ON OVERARM ADAPTER

The face on flange or adapter should be thoroughly cleaned as this aligns milling head square with table working surface. Then clean mounting surface of head carefully. When bolting the head to the adapter or overarm, tighten nuts evenly, using normal pressure. Care should be taken to avoid excessive pressure since this will cause distortion in the quill.

HANDLES

When crating, the three ball crank handles are turned facing each other. The handles should be reversed.

LUBRICATION

Do not operate machine until properly lubricated. Follow the instructions given in Dwg. 4, page 6.

INSPECTION

Machine is carefully inspected and lined up before it leaves our factory. Sketch # 1 and 2 shows the way your machine is lined up.

ALIGNMENT OF HEAD

In case of precision boring or work of that nature, where it is necessary to have head perfectly square with the table, use method prescribed below. For normal milling, graduations on turret and head are close enough. To set head perfectly square with table, Sketch #1. This may be done with head and adapter on overarm, by adjusting adapter through worm gear on adapter. Loosen three binding bolts but leave drag on same for fine adjustment. Mount indicator in spindle nose as shown in Sketch #2 and 2, and indicate parallel.

Note: When indicating as in Sketch 1, it should be noted that the table is fitted to be slightly high in front, usually about .005.

TABLE SQUARE WITH SPINDLE THRU
TRANSVERSE AXIS

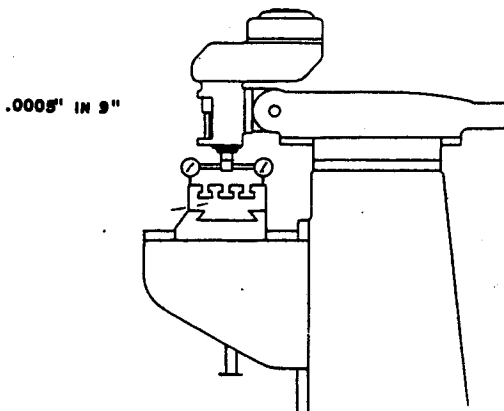

Sketch #1

TABLE SQUARE WITH SPINDLE THRU
LONGITUDINAL AXIS

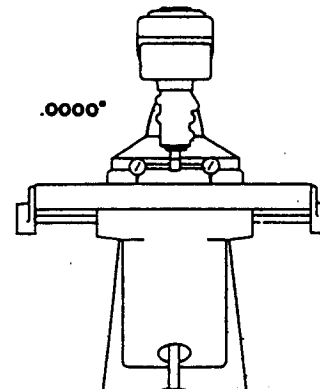

Sketch #2

RECOMMENDED LUBRICATION FOR THE BRIDGEPORT TURRET MILLING MACHINE

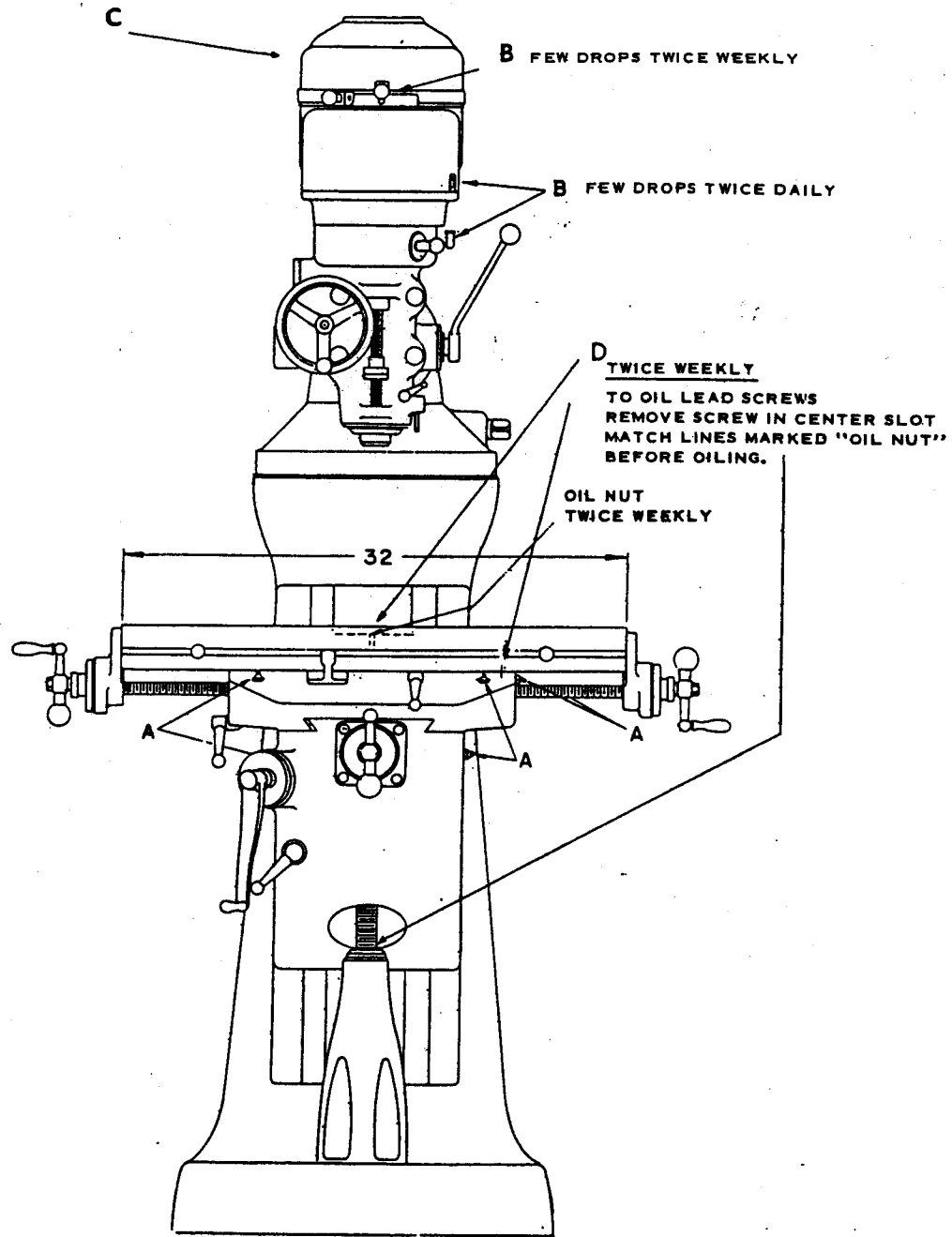

A. Way Surfaces

"Sunoco" Waylube #80
or equivalent

WEEKLY

B. Milling Heads (Spindle Bearings)

S.A.E. 10 or 10W Light Oil

C. Motors are greased for life of bearings

For further instructions refer to
motor manufacturer's instruction book

D. Lead Screws

Shell Cornea Oil 41
Socony Gargoyle Vactra Oil No. 2

ATTACHMENTS: POWER FEED

Shell Cornea Oil 33
Socony Gargoyle Vactra Oil
(Heavy Medium)

SHAPING ATTACHMENT

Shell Nassa Oil J78 or K79
Socony Gargoyle Vactra
Oil (Heavy Medium)

SHAPING ATTACHMENT (Warm drive)

Shell Nassa Oil J78 or K79
Socony Cylinder Oil 600W

ADJUSTMENT OF TABLE GIB

The table is provided with a full length tapered gib in the saddle, with an adjusting screw on the left side. To take up gib, tighten large screw slightly and repeat until a slight drag is felt when moving the table by hand. (Sketch 3)

Sketch #3

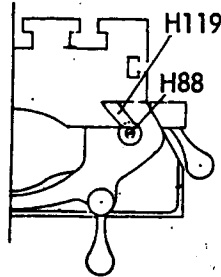
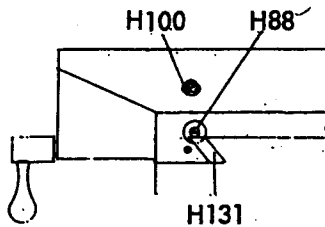

Table-saddle gib

ADJUSTMENT OF SADDLE AND KNEE GIBS.

A tapered gib is used for adjusting the saddle bearing on the knee. This forms a guide for the saddle. To tighten gib same principal as described above is used; however, chip wiper has to be removed first. (Sketch 4)

Sketch #4



Saddle-knee gib

ADJUSTMENT OF KNEE GIB

Remove chip wiper and adjust screw until smooth movement is attained. (Sketch 5)

Sketch #5

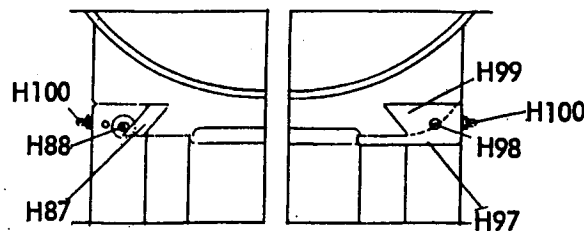

Knee-Column gib

CLAMPING TABLE, SADDLE AND KNEE

When milling with longitudinal table feed only, it is advisable to clamp the knee to the column and the saddle to the knee to add rigidity to these members and provide for heavier cuts with a minimum of vibration. The saddle locking lever is located on the left-hand side of saddle. (Sketch 6) Excessive pressure can cause slight table bind. Use moderate clamping pressure, as this will hold saddle sufficiently.

Sketch #6

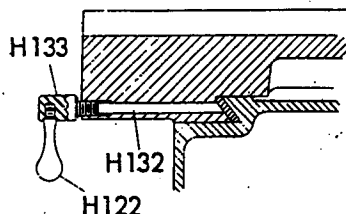

The table clamping lever is located on front of saddle and should always be clamped when longitudinal movement is not required. (Sketch 7)

Sketch #7

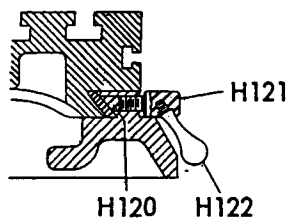

The knee clamping lever is at the left side of the knee and should be drawn upward to clamp the knee. (Sketch 8) This is only a tension brake and will not lock the knee completely. Leave clamped at all times unless using knee in operation.

Sketch #8

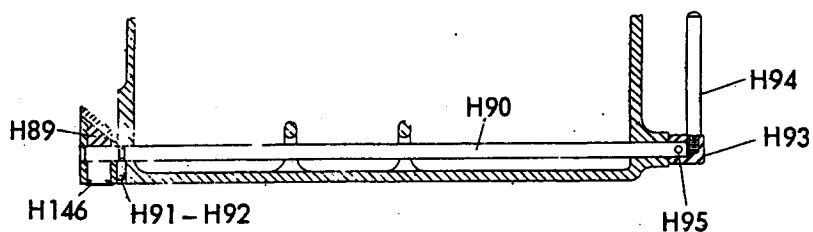

REMOVING OF TABLE

Remove as follows: Ball crank handles, dial holders, bearing brackets. Screw will then turn all the way so that it can be removed. When this is accomplished, the table can easily be taken off merely by sliding from saddle.

REMOVING OF SADDLE

Follows along the same lines as removing table; however, it is necessary to remove entire front bracket assembly completely. Then remove nut bracket which has become accessible after table has been removed. See pages 9 and 10, Drawing 5 and 6.

POWER FEED ATTACHMENT

The feed box is equipped with an overload release. If the table stops during operation and a series of clicks is heard, feed is overloaded. When load is relieved, power feed will resume operation. If the overload clutch jams, the 1/8" shearing pin (Drawing 5) will break. This will prevent damage to the power feed box.

INSTRUCTIONS FOR INSTALLING POWER FEED IN FIELD

First remove left handle, lock nut, dial, and end bracket. Then remove right handle and also right bearing and bracket. The next step is to remove retaining screw (see Drawing 6) after lock screw has been taken out. The screw and nut will then slide out. This procedure is reversed for installing power feed screw and nut. Power feed unit is easily installed and needs little explanation. Do not neglect to put Shear Pin in Place. (Drawing #5).

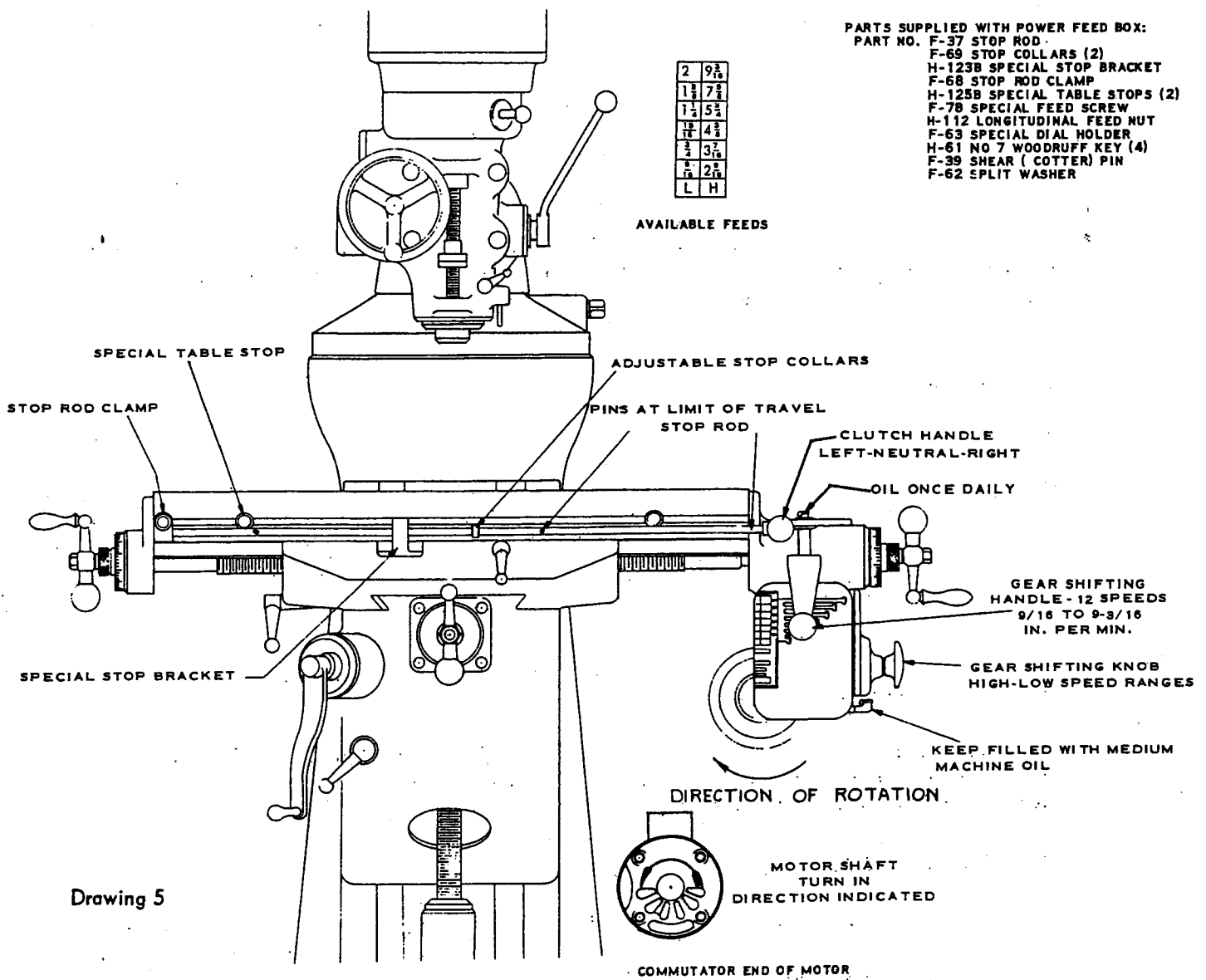

Drawing 5

LONGITUDINAL FEED SCREW ASSEMBLY WITH POWER FEED

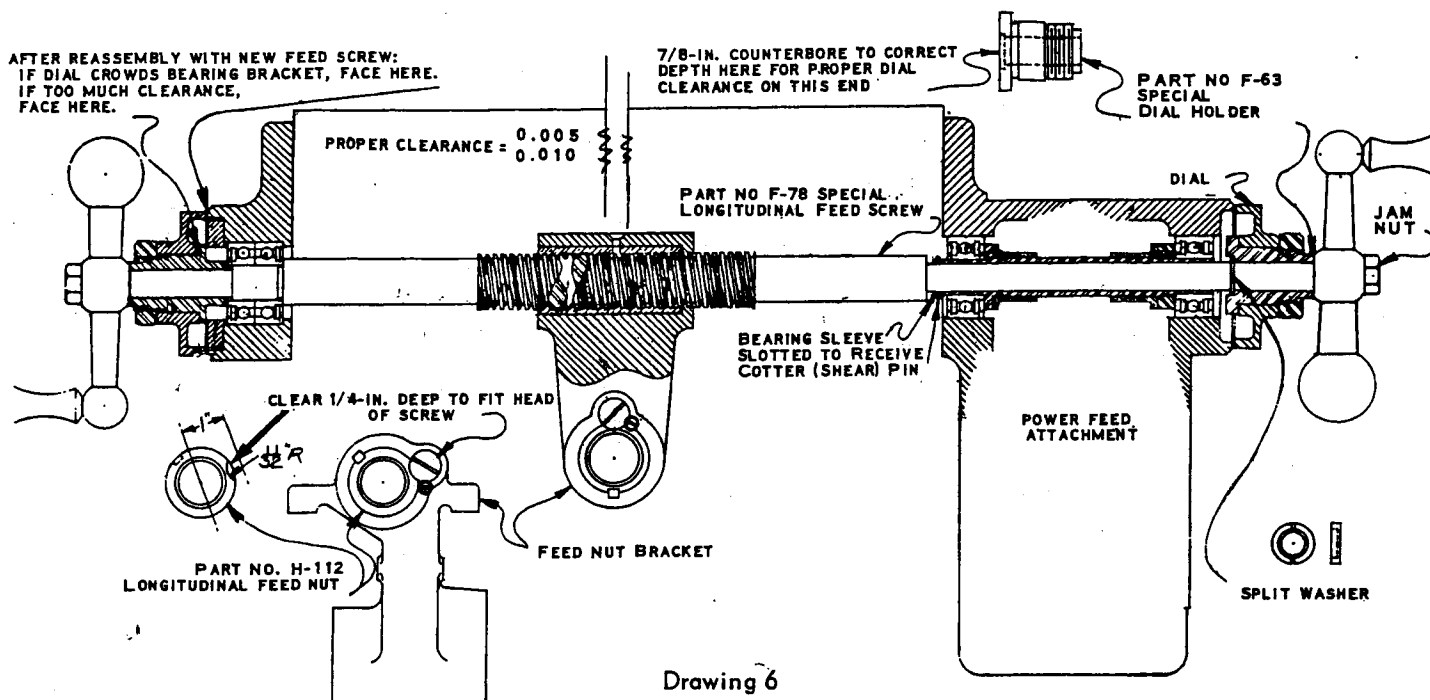

REMOVING REGULAR SCREW

Remove (left side) bracket - (the 1/2" 20 nut, dial holder and nut, (4) 3/8 16 x 1" cap screws, and H-115 bracket and bearing by tapping with plastic hammer). Remove (right side) bracket - using same procedure. Remove 8/32" locking screw from feed nut bracket. Also remove 5/16" 18 binding screw. Pull, to remove lead screw and lead nut from lead screw bracket.

INSTALLING POWER FEED

Move table to right side, half way. Insert power feed lead screw and nut into bracket from left side; long end of screw should be on right side.

Mark with scribe on bushing where binding screw goes; remove screw and nut from bracket. Remove the screw from the nut. File relief flat on nut to receive binding screw. (Make certain flat is not filed too deep.) Insert screw and nut into bracket with binding screw and locking screw. Reassemble left hand bracket and dial holder complete. Mount power feed box on right with dowel pins and 3/8" cap screws (3). Insert split washer into groove in lead screw. Insert Woodruff keys. Push power feed dial holder onto screw. (Make sure split washer does not fall out.)

Assemble dial and nut onto dial holder. Insert cotter pin through hole in lead screw at back of power feed box. If dials drag, remove some stock from outside rib. If too much clearance, remove stock from inside rib. Remove door and fill with oil to height of oiler.

Assemble stop rod as illustrated. Drill 3/32" hole into stop rod to receive 3/32" pins which limit the travel of the power feed. Locate these by cranking table to each extreme travel and locate pin to kick off feed rod about 1/4" before extreme travel.

INSTALLING MEASURING ATTACHMENT (Sketch #17)

For locating holes to greater accuracy on the Bridgeport Turret Milling Machine.

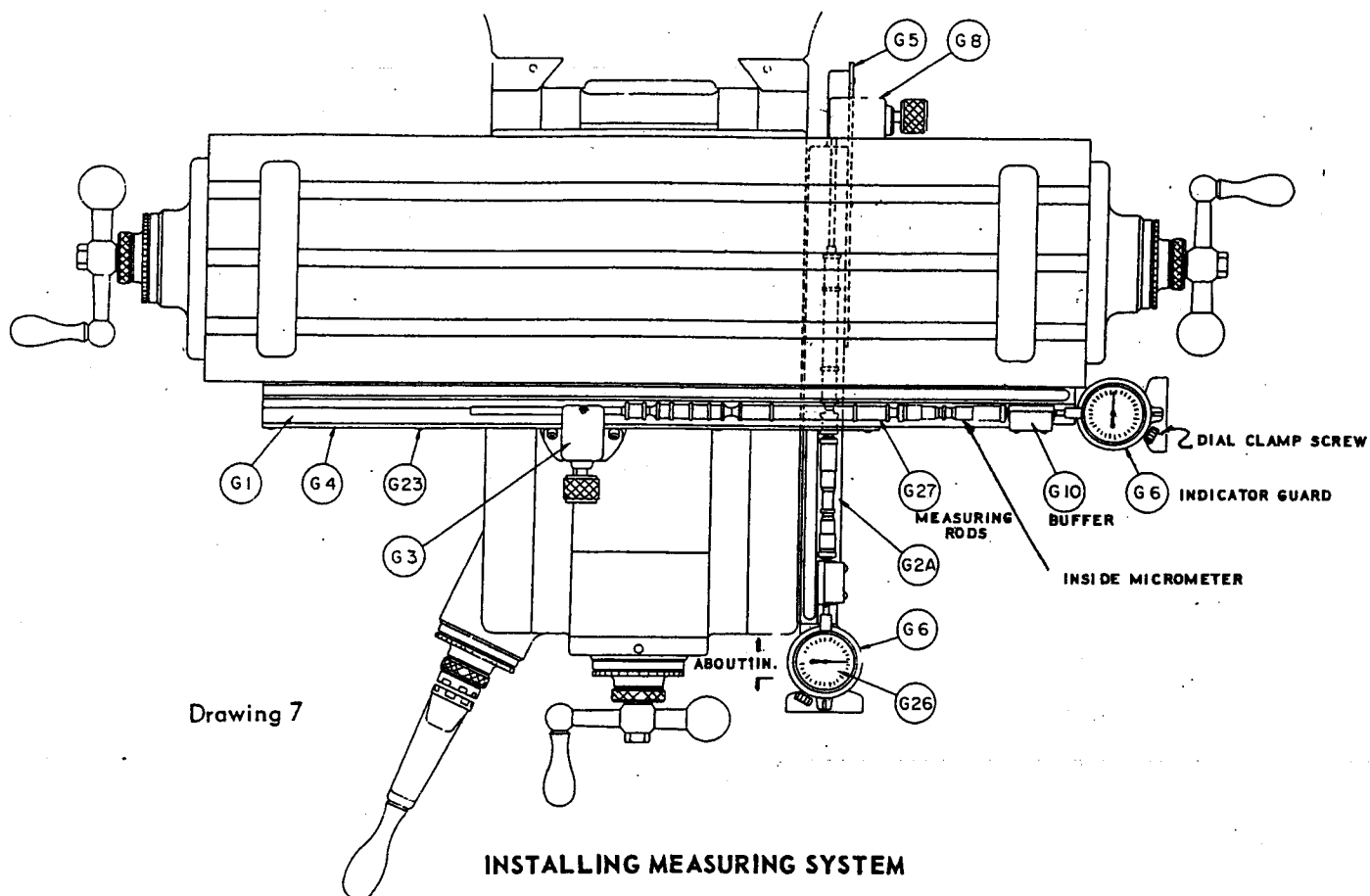

Install knee trough in counterbored holes on right hand side of knee. Indicate from dovetail on knee for parallelism within .003 using 5/8 rod in trough - Indicate top and side. Bring saddle as far front as possible. Mount saddle bracket into trough with rolls on spindle of bracket. Center rolls in trough and scribe holes in saddle. Drill 5/16 hole 1/2" deep (Caution on depth; do not drill into dovetail) Use 3/8-16 Tap. Mount Bracket with 3/8-16 x 1 1/2 Cap screw. Caution: Saddle and table bracket alignment with trough is essential for good operation.

TABLE TROUGH

Remove table stops and stop bracket from front of table. Remove table lock bolt and handle. (Reposition handle after trough is installed by facing end of lock bolt.

Mount table trough with tee nuts into tee slot on front of table. Indicate from top of table for parallelism - within .003 - same as cross feed trough.

With rolls on spindle of table stop bracket, center rolls into trough and secure with 3/8-16 x 2" cap screw. Adjustment may be made by filing bottom of bracket or shimming if necessary.

Locking table on saddle with table lock knobs (Reed clamp on troughs) shouldn't disturb indicator needle more than .0001 if brackets are aligned properly.

USING MEASURING ATTACHMENT

Any hole may be located by two dimensions at right angles. The table and saddle are located separately by combinations of positive measuring instruments consisting of measuring rods for even inches, an inside micrometer for fractions, and a dial indicator reading to one ten-thousandth. The "zero" point from which other dimensions are taken is established for each slide after locating the first hole and is not changed until the job is finished. Other holes to be bored are located from these two "zero" points by measurements at right angles. The measuring rods required are added, and the inside micrometers set and locked at the proper readings. The table and saddle are then carefully positioned with the dial indicators and clamped in place. After checking indicator readings, the hole is ready to be bored.

CAUTION: Make certain that the head is indicated properly so that the head is absolutely square with the table.

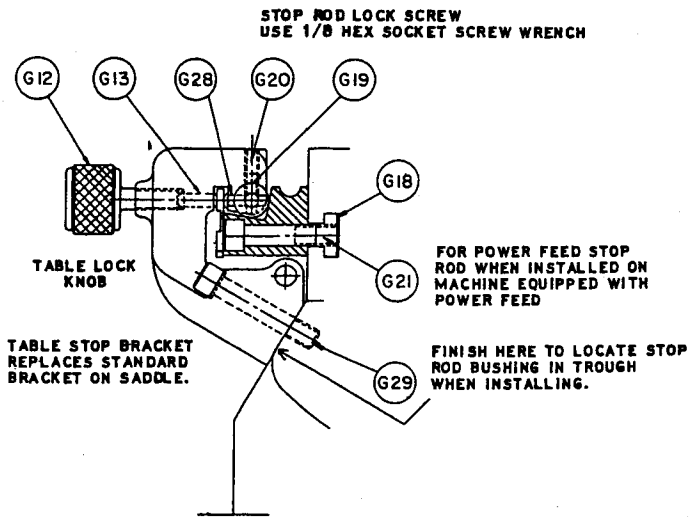

Sketch #9

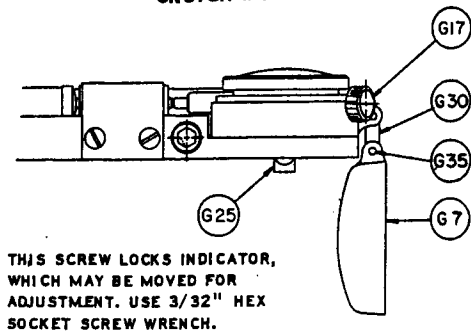

Sketch #11

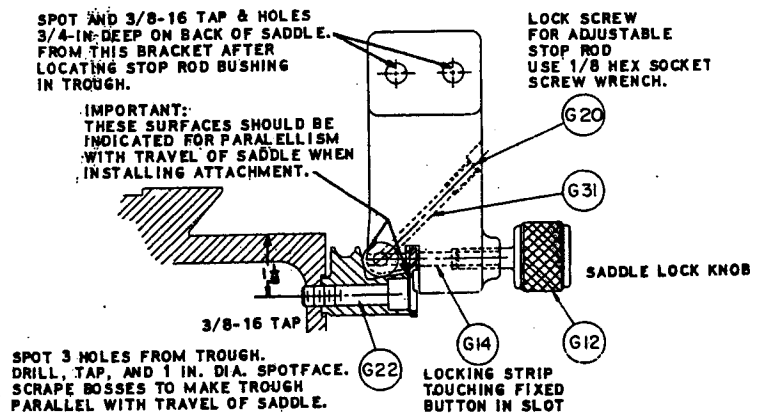

Sketch #10

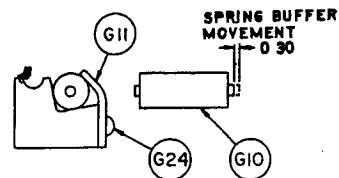

Sketch #12

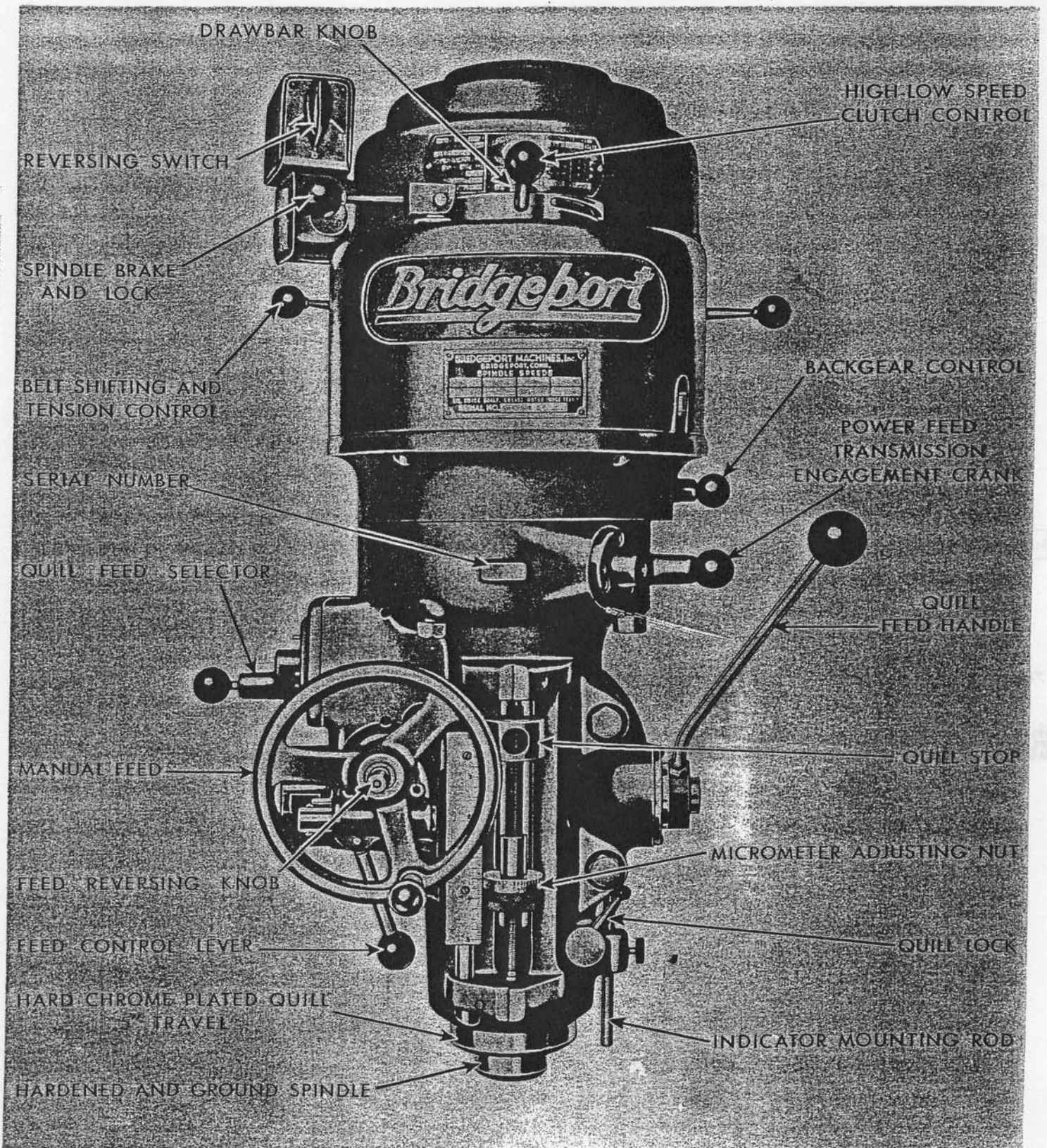

MOUNTING MOTOR ON ATTACHMENT

Place belt over bottom step of spindle pulley, then place motor in housing and lower to place, switch being on left hand side.

PLACING AND ADJUSTING BELTS

Release lock nut handle which is the handle on right of belt housing and also handle on left side and adjust V belts to proper driving tension, then tighten both motor clamping handles.

MACHINE IS READY TO OPERATE

If quill and head are to be used in stationary position, quill lock should be applied. Micrometer depth stop scale is graduated in 20ths of an inch, pitch is .050 and nut is graduated in thousands. By utilizing these graduations it is possible to work very accurately as far as different depths are concerned. Micrometer nut when in position is locked securely by tightening micrometer lock nut.

OPERATING INSTRUCTIONS

When tightening or loosening the draw bar it is necessary to lock the spindle. To accomplish this, use spindle brake and lock which is located at top of belt housing, turning it either to the right or left until it binds, then raise handle.

Drawbar has 7/16-20 right hand thread and should be tightened with normal amount of pressure using wrench furnished with machine. To loosen collet back off drawbar and if collet does not open immediately give knob on top of drawbar a slight tap. Spindle has non sticking taper and collets should release readily.

SPINDLE BRAKE

Lever can be moved in either direction to stop spindle; however, when locking spindle, lever should be moved to right or left and then raised.

CAUTION: Be certain that the spindle brake is released before starting the motor. This is important as the motor can be damaged if switch is left on with brake in locked position.

REVERSING SWITCH is used to obtain clockwise or counter clockwise rotation of spindle.

Note: Due to back gear construction, when machine is running in low speed range, spindle rotation is opposite to that of high speed range. Therefore forward on your reversing switch becomes reverse switch in low speed range.

HIGH LOW SPEED CLUTCH CONTROL is directly in front of motor. When knob is in position, as shown on picture, clutch is in high speed position. To put clutch into low speed position turn lever to the extreme right. It is necessary to rotate spindle while engaging high speed clutch. This can be accomplished by either turning spindle nose by hand or by turning drawbar knob using wrench, providing drawbar is pulled up tightly.

CAUTION: Do not shift clutch while motor is running.

Back gear control is used in conjunction with the high low speed clutch control above back gear control handle is stamped IN and OUT. When back gear control handle is in OUT position, which is the position furthest from face of machine, then HIGH LOW speed clutch control should be located as illustrated in photograph. With these controls in position as explained, head is set for operation in high speed range (660-2720 RPM). When back gear control lever moved to IN position and HIGH LOW speed clutch control moved to extreme right then the head is ready for operation in the low speed range (80-325 RPM).

POWER FEED TRANSMISSION ENGAGEMENT CRANK engages power feed worm gear. When lever is in position as indicated in photograph, the power feed worm gear is engaged. To disengage worm gear, pull knob out and crank handle in clockwise or down direction and move to opposite position.

Note: Crank cannot be swung around in counter clockwise direction; however no damage will occur if moved in this direction. To engage the worm a counter clockwise movement is required.

CAUTION: Power feed worm gear may be engaged when spindle is rotating, however it should be engaged gently to avoid damage to worm gear. The worm gear may be disengaged at any time.

IMPORTANT: It is recommended that the Power Feed worm gear be disengaged whenever the power feed is not required. This will avoid unnecessary wear on power feed worm gear.

QUILL FEED SELECTOR

This crank is used for selecting the three feeds; 1.5, 3 and 6 thousandths per revolution. It is shifted by pulling knob out and turning from one position to the other. Feeds are stamped on cover below indentation hole. Feed is more readily engaged when spindle is running.

FEED REVERSING KNOB

Position of this handle depends upon direction of spindle rotation. If boring with right hand cutting tools, pull feed handle towards operator until clutch becomes engaged.

Neutral position is between forward and reverse position. It is recommended that the handle be left in neutral position when not in use.

MANUAL FEED

Reversing clutch knob should be in neutral position and feed control lever engaged. Clockwise rotation of handwheel moves quill down. The Manual Feed Handwheel and the quill feed handle may be disengaged by moving outward about 1/8".

Note: Feed control lever must be engaged in order to use manual feed controls. Manual Feed Handle and Handwheel may be taken off when not in use.

FEED CONTROL LEVER

Engages over-load clutch on pinion shaft when thrown to left and will stay engaged until either quill stop comes in contact with micrometer nut, forcing feed control lever to drop out automatically, or released manually by throwing lever to right.

Note: Feed Control Lever is carefully set at plant to throw out automatically when quill stop goes against micrometer nut or against safety pin in top. However, if this should go out of adjustment it may easily be brought back by regulating the screw located at bottom of tripping rod.

CAUTION: When adjusting the screw, check automatic throw off in both directions; that is with micrometer nut against the quill stop for down position and quill stop against throw out pin for up position.

QUILL FEED HANDLE

May be removed by simply pulling handle off end of shaft. It is recommended that handle be disengaged when using power feed.

QUILL STOP is used to disengage automatic feed in either direction as well as the setting point for working to given depths.

MICROMETER ADJUSTING NUT is used for setting of depths. Each graduation on nut indicates one thousand of depth, it reads directly to scale mounted along side of it. Depths may be obtained by setting micrometer nut in conjunction with quill stop.

QUILL LOCK

This is a positive quill lock to be used when quill is in stationary position such as milling operations. It is recommended that this lock be used whenever quill movement is not desired.

INDICATOR MOUNTING ROD is used for the fastening of an indicator.

LUBRICATION

Do not operate machine until properly lubricated. Lubrication of head is obtained by use of the drip feed method through two oil cups located at right side of belt housing, with light machine oil such as Socony D.T.E. light or equivalent.

POSITION OF OVERARM can be regulated by loosening two bolts on turret and pulling arm in or out to desired position.

CAUTION: Care should be taken to lock overarm securely after setting.

Note: It is recommended that on heavy milling work, head should be kept as close to face of turret as possible, as maximum rigidity is then obtained.

OPERATION

To operate in high speed range, move high low speed clutch control handle to extreme left then put back gear control in OUT position.

Then, if power feed is desired, crank power feed transmission engagement to IN position, (refer back to explanation of controls) and feed reversing knob should be pushed in for down feed and pulled out for up feed.

The next step is to throw feed control lever to left. Power feed is now in operation in high speed range. Feeds can be selected by cranking quill feed selector to desired feeds.

BACK GEAR OR LOW SPEED RANGE

Stop spindle, then move high low speed clutch control to extreme right and also back gear control handle over to IN position.

RECOMMENDATIONS

Use 2, 3, or 4 flute end mills. 8 flute end mills are usually not as satisfactory. When using shell or face mills standard cutter practice should be observed.

Power feed can be used for drilling up to 3/8" diameter drills. Use manual feed for drills larger than 3/8".

Overload clutch is set at factory to hold up to 200 lbs. DOWN pressure on quill, which will accommodate drills up to 3/8" diameter in mild tool steel.

CAUTION: This clutch should not be tampered with in the field.

GENERAL SPEED RECOMMENDATIONS

Material to be Cut	Feet Per Minute		
	Rough Cut	Rough and Finish	Light and Finish Cut
Cast Iron-Soft-(Under 200 Brinnell)	70	80-90	120
Cast Iron-Med.-(200-300 Brinnell)	55	60-70	90
Cast Iron-Hard-(Over 200 Brinnell)	40	50-60	70
Steel (Chrome Nickel 40-45 Shore)	30	40	50
Steel (Stainless)	60	80	90
Steel (Low Carbon)	80	90	140
Steel (High Carbon)	40	50	70
Bronze (Medium)	90	120	150
Bronze (Hard)	65	90	130
Brass (Hard)	100	150	200
Copper	150	200	300
Duraluminum	400	---	600
Aluminum	600	---	1000

TABLE OF CUTTING SPEEDS AND FEEDS

Feet Per Minute	15	20	25	30	40	50	60	70	80	90	100
Diameter, Inches	Revolutions Per Minute										
1/16"	917	1222	1528	1833	2445	3056	3667	4278	4889	5500	6112
1/8"	458	611	764	917	1222	1528	1833	2139	2445	2750	3056
3/16"	306	407	509	611	815	1019	1222	1426	1630	1833	2037
1/4"	229	306	382	458	611	764	917	1070	1375	1375	1528
5/16"	183	244	306	367	489	611	733	856	978	1100	1222
3/8"	153	204	255	306	407	509	611	713	815	917	1019
7/16"	131	175	218	262	349	437	524	611	698	786	873
1/2"	115	153	191	229	306	382	458	535	611	688	764
5/8"	91	122	153	183	244	306	367	428	489	550	611
3/4"	76	102	127	153	204	255	306	357	407	458	509
7/8"	65	87	109	131	175	218	262	306	349	393	437
1"	57	76	95	115	153	191	229	267	306	344	382
1 1/8"	50	67	84	102	136	170	204	238	272	306	340
1 1/4"	45	61	76	91	122	153	183	214	244	275	306
1 3/8"	41	55	69	83	111	139	167	194	222	250	278
1 1/2"	38	50	63	76	102	127	153	178	204	229	255
1 5/8"	35	47	58	70	94	118	141	165	188	212	235
1 3/4"	32	43	54	65	87	109	131	153	175	196	218
1 7/8"	30	40	50	61	81	102	122	143	163	183	204
2"	28	38	47	57	76	95	115	134	153	172	191

J PARTS LIST

J-1	QUILL HOUSING	J-91	BRAKE LOCK WASHER
J-2	GEAR HOUSING	J-92	BRAKE LOCK & HANDLE
J-3	GEAR HOUSING COVER	J-93	BRAKE LOCK PIN
J-4	BELT HOUSING	J-94	LOWER CLAMPING BOLT SPACER
J-5	SPINDLE PULLEY	J-95	COUNTERSHAFT
J-6	MOTOR PULLEY	J-96	COUNTERSHAFT GEAR
J-7	TIMING BELT PULLEY	J-97	GEARSHIFT PLUNGER
J-8	TIMING BELT PULLEY FLANGE	J-98	CLUSTER GEAR SHIFT CRANK
J-9	WORM GEAR CRADLE	J-99	FEED DRIVE CLUSTER GEAR
J-10	OVERLOAD CLUTCH TRIP LEVER	J-100	FEED DRIVE CLUSTER GEAR (CENTER)
J-11	FEED GEAR SHIFTER FORK	J-101	FEED DRIVE CLUSTER GEAR (UPPER)
J-12	BACK GEAR SHIFTER FORK	J-103	FEED DRIVE GEAR
J-13	SPINDLE PULLEY BEARING SLEEVE	J-104	CLUSTER GEAR INPUT SHAFT
J-14	SHIFT CRANK	J-105	FEED DRIVING GEAR
J-15	CLUSTER GEAR COVER	J-106	CLUSTER GEAR SHAFT
J-16	SPRING COVER	J-107	CLUSTER GEAR KEY
J-17	FEED TRIP BRACKET	J-108	BEVEL GEAR BEARING
J-18	CLUTCH ARM COVER	J-109	BEVEL GEAR THRUST SPACER
J-20	MOTOR SWITCH BRACKET	J-110	FEED REVERSE BEVEL GEAR
J-21	HANDWHEEL	J-111	FEED WORM SHAFT THRUST WASHER
J-23	FELT RETAINER RING	J-112	FEED REVERSE CLUTCH
M-24	MICRO SCREW JAM NUT	J-113	HANDWHEEL CLUTCH SPRING SCREW
J-27	TIMKEN BEARING SPACER FOR J-100 TO J-1199 ONLY	J-114	FEED WORM SHAFT BUSHING
J-29	SPINDLE LOCKNUT BINDING	J-116	REVERSE CLUTCH ROD
J-31	DRAWBAR FOR R-8 COLLET	J-117	REVERSE KNOB
J-32	DRAWBAR KNOB	J-118	HANDWHEEL CLUTCH
M-33	PINION SHAFT HUB SLEEVE	J-119	HANDWHEEL BUSHING
J-34	QUILL NOSEPIECE FOR J-100 TO J-1199 ONLY	J-121	WORM SHAFT KEY
J-35	QUILL SKIRT	J-122	FEED DRIVING GEAR KEY
J-36	QUILL STOP KNOB	J-123	BEVEL PINION WASHER
J-37	QUILL STOP MICRO SCREW	J-124	FEED WORM GEAR SHAFT SLEEVE
J-38	MICROMETER NUT	J-125	WORM GEAR SPACER
J-39	REVERSE TRIP BALL LEVER	J-126	FEED DRIVE WORM GEAR
J-40	FEED REVERSE TRIP PLUNGER	J-127	FEED DRIVE WORM GEAR SHAFT
J-41	REVERSE TRIP BALL LEVER SCREW	J-128	FEED ENGAGE PIN
J-42	FEED TRIP LEVER	J-129	WORM GEAR CRADLE THROW-OUT
J-43	FEED TRIP PLUNGER	J-130	SHIFT SLEEVE
M-43	HANDWHEEL HANDLE	J-131	MOTOR LOCKNUT
J-44	TRIP PLUNGER BUSHING	J-132	MOTOR LOCKNUT HANDLE
J-45	TRIP PLUNGER	J-133	MOTOR MOUNTING STUDS
J-46	FEED TRIP PLUNGER BUSHING	J-134	MOTOR MOUNTING STUD WASHERS
J-47	CAM ROD SLEEVE ASSEMBLY	J-135	CLUSTER GEAR KEY
M-47	LOCK HANDLE	J-136	WORM CRADLE BUSHING
J-48	CAM ROD	J-137	CLUSTER GEAR KEY
J-49	TRIP HANDLE	J-139-S	COLLET ALIGNING SCREW
J-50	LOCKNUT BINDING PLUG FOR J-100 to J-1199 ONLY	J-140	WORM GEAR
J-51	OVERLOAD CLUTCH LEVER SPRING PLUNGER	J-141	NUT
M-51	INDICATOR ROD SCREW	J-142	KEY
J-52	OVERLOAD CLUTCH WASHER	J-143	1/4 20 x 3/8 SOCKET SET SCREW
M-52	INDICATOR ROD	J-144	GEAR
J-53	CLUTCH RING	J-145	FEED SHIFT ROD
M-53	PINION SHAFT HUB	J-146	FEED REVERSE BEVEL PINION
J-54	OVERLOAD CLUTCH SLEEVE	J-147	CLUSTER GEAR SHAFT UPPER BEARING
M-54	PINION SHAFT HUB HANDLE	J-148	PINION SHAFT HUB SCREW
J-57	OVERLOAD CLUTCH SLEEVE KEY	J-149	DRAWBAR WASHER
J-58	OVERLOAD CLUTCH	J-150	OUTSIDE CLOCKSING PIN
J-59	OVERLOAD CLUTCH RING	J-151	TRIP LEVER PIN
J-60	OVERLOAD CLUTCH WORM GEAR	J-152	BACKGEAR SHIFT BUSHING
J-61	PINION SHAFT WORM GEAR SPACER	J-153	BACKGEAR SHIFT CRANK
F-61	OVERLOAD CLUTCH LOCKNUT	J-154	CLUTCH RING PIN
J-62	QUILL PINION SHAFT BUSHING	J-155	1/2" T-BOLT
J-63	QUILL PINION SHAFT	J-156	FEED REVERSE KNOB STUD
J-64	QUILL PINION	J-157	QUILL MICRO STOP NUT
J-65	QUILL LOCK SLEEVE	J-159	KEY FOR #30 STD TAPER SPINDLE
J-66	QUILL LOCK SLEEVE	J-166	SPINDLE (SERIAL J-1200 AND UP)
J-67	QUILL LOCK BOLT	J-167	QUILL (SERIAL J-1200 AND UP)
J-70	VERTICAL TEE BOLT	J-169	SPINDLE DIRT SHIELD
J-71	VERTICAL TEE BOLT WASHER	J-170	BEARING SPACER - LARGE FROM J-1750
J-72	SPLINED GEAR HUB	J-171	BEARING SPACER - SMALL
J-73	BULL GEAR KEY	J-172	NOSEPIECE
J-74	SPINDLE BULL GEAR	J-176	SLEEVE FROM SER. J-1750
J-75	SPINDLE PULLEY HUB	J-188	FEED WORM SHAFT STARTED WITH SER. NO. 5500
J-76	PULLEY COLLAR	J-190	1/2 - 13 SPECIAL HEX NUT OPTIONAL EQUIP.
J-77	OILER TUBE	J-192	WASHER
J-78	OIL PLUG	J-193	PLUG FOR 5/8 HOLE
J-79	SPINDLE PULLEY KEY	J-250	1/4 - 20 1/2 LG. SOCKET SET SCREW KP
J-80	UPPER BEARING SPACER (LARGE)	J-251	5/16 - 18 x 5/16 SOCKET SET SCREW
J-81	UPPER BEARING SPACER (SMALL)	J-252	5/16 - 18 x 5/8 LG. SOCKET CAP SCREWS
J-82	BEARING SLEEVE LOCKNUT	J-253	KOHINOOR #5000 - 315 SNAP RING
J-83	UPPER BEARING LOCKNUT	J-254	3/16 x 1/2 LG. DOWEL PINS
J-84	CAM RING	J-255	#10-24 x 3/8 LG. R. HEAD SCREW
J-85	SPINDLE CLUTCH LEVER	J-256	COMPRESSION SPRING
J-86	SPINDLE CLUTCH CAM RING PIN	J-257	5/16 - 18 x 1/2 LG. K.P. SOCKET SET SCREWS
J-87	BRAKE BLOCK	J-258	V BELT
J-88	BRAKE RING SCREW	J-259	#6 - 32 x 3/8 LG. FLAT HEAD SCREWS
J-89	BRAKE LOCK STUD	J-260	3/16 x 3/4 LG. DOWEL PIN
M-89	CLOCKSING STUD	J-261	1/8 x 7/8 LG. ROLL PIN

J-262 COMPRESSION SPRING
 J-263 10-32 x 1/4 LG. K.P. SET SCREW
 J-264 #10-24 x 1/2 LG. CAP SCREW
 J-265 1/4 - 20 x 1 LG. CAP SCREW
 J-267 #10 - 24 x 1-1/2 LG. CAP SCREW
 J-268 1/4 - 20 x 1/2 SOCKET SET SCREWS
 J-269 1/4 - 20 x 3/8 LG. SOCKET HEAD CAP SCREW
 J-272 N-06 LOCK NUT
 J-273 W-06 LOCKWASHER
 J-274 5/16 - 18 x 5/16 SOCKET SET SCREW K.P.
 J-275 1/4 - 20 x 1/4 LG. SOCKET SET SCREW
 J-276 10-32 x 5/16 LG. RD. HD. SCREW
 J-278 3/8 - 24 x 5/8 SCREW
 J-279 #6 - 32 x 3/8 SOCKET SET SCREW
 J-280 1/8 x 7/16 LG. ROLL PIN
 J-281 3/16 x 5/8 LG. DOWEL PIN
 J-282 1/8 x 9/16 LG. ROLL PIN
 J-283 COMPRESSION SPRING
 J-284 BLACK PLASTIC BALL HANDLES 1" DIM.
 J-285 8-32 x 5/8 LG. RD. HD. SCREW
 J-286 #3 WOODRUFF KEY
 J-287 #7 WOODRUFF KEY
 J-288 #5108 - 59 KOHINOOR SNAP RING
 J-289 7/16 - 14 HEX NUT HARDENED (AMERICAN STD. REGULAR)
 J-290 N-08 SPECIAL 5/16 THICK BEARING LOCKNUT
 J-291 W-08 LOCKWASHER
 J-292 1 PR. #208 BEARINGS
 J-293 1 PR. #207 BEARINGS
 J-294 WICK 1/8 O.D.
 J-295 GITS OIL CUP #1207
 J-296 3/32 x 5/8 LG. ROLL PIN
 J-297 W. B. JONES #167 - A EXT. SPRING (LINDQUIST)
 J-298 10-32 x 1/4 LG. SOCKET SET SCREWS
 J-299 #9 WOODRUFF KEY
 J-300 5/8 - 18 HEX JAM NUT
 J-301 ND #99503 DOUBLE SEAL BEARING ABEC 3
 J-303 B-66 TORRINGTON NEEDLE BEARING
 J-304 3/8 - 24 HEX JAM NUT
 J-305 A-672-4 OILITE BEARING
 J-306 3/32 x 5/16 LG. PIN
 J-307 BOSTON WORM #HLVH
 J-308 .110 DIA. x 7/16 LG. PIN
 J-309 3/32 x 3/4 LG. ROLL PIN
 J-310 3/16 STEEL BALL
 J-311 COMPRESSION SPRING
 J-312 1/4 - 20 x 5/16 LG. SET SCREW
 J-315 #10-24 x 3/8 LG. K.P. SET SCREW
 J-316 5/16 x 7/8 LG. DOWEL PIN
 J-318 3/8 LOCKWASHER
 J-319 5108 - 62 WALDES SNAP RING
 J-321 SAFETY CLUTCH SPRING
 J-322 MICROMETER SCALE
 J-323 6-32 x 1/4 LG. RD. HD. SCREW
 J-324 FEED REVERSE BEVEL GEAR
 J-326 BILLING #1166 WRENCH
 J-327 STEEL PINION
 J-328 CLOCK SPRING 1" x .020" x 42"
 J-329 TIMING BELTS 1-1/4" WIDE
 J-330 COMPRESSION SPRING
 J-331 5108 - 37 KOHINOOR SNAP RING
 J-333 BLACK PLASTIC BALL HANDLES 13/8 DIM. SAME AS M-54
 J-334 5/16 x 2" LG. DOWEL PIN
 J-335 #8 SPLIT LOCKWASHER
 J-336 SNAP RING 5100-25
 J-338 #2002 GITS OIL CUP
 J-339 SPINDLE SPEED PLATE
 J-340 OPERATING INSTRUCTION PLATE
 J-345 10 - 32 x 3/8 SOCKET SET SCREWS
 J-348 FAFNIR MM 207 WI-CR-DB. SPEC. E5227. START AT J-1200
 J-349 FAFNIR M206 K SPEC. E 6578 OR NORMA HOFFMAN 206 S-685 A START AT SER. #J-1750
 J-350 1/4 - 20 MOCK-IT LOCKSCREW
 J-351 5/16 - 18 MOCK-IT LOCKSCREW
 J-352 1/8 x 3/4 LG. DOWEL PINS
 J-353 BUSHING
 J-355 1/2" - 13 STD. HEX NUT
 J-356 3/8 - 24 FLOPLOC STOP & LOCKNUT
 J-358 6-32 x 1/4 SOCKET SET SCREW K.P. STARTED WITH SER. #J-8300
 J-359 1/4-20 JAM - NUT
 J-362 5/16 - 18 JAM NUT
 J-363 5/16 EXTERNAL LOCK WASHER
 J-365 1/4 x 3/4 ROLL PINS
 J-366 NAME PLATE
 J-368 OIL STRAINER FOR QUILL BRG.
 J-839 SWITCH BRACKET
 M-72 WASHER

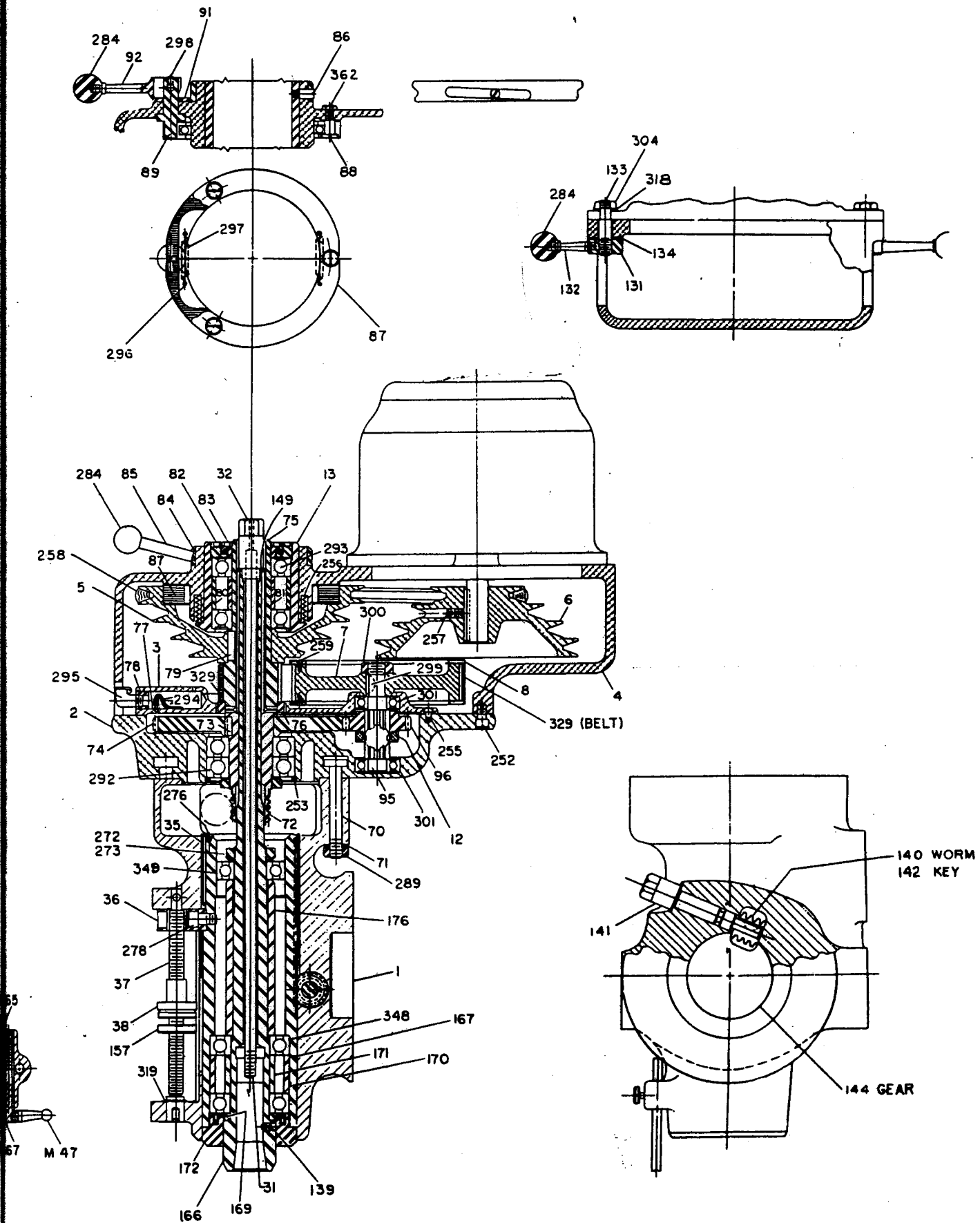

1 H.P. MILLING ATTACHMENT

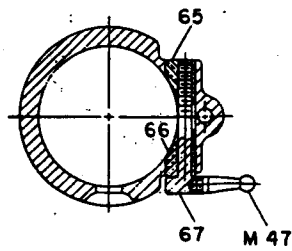
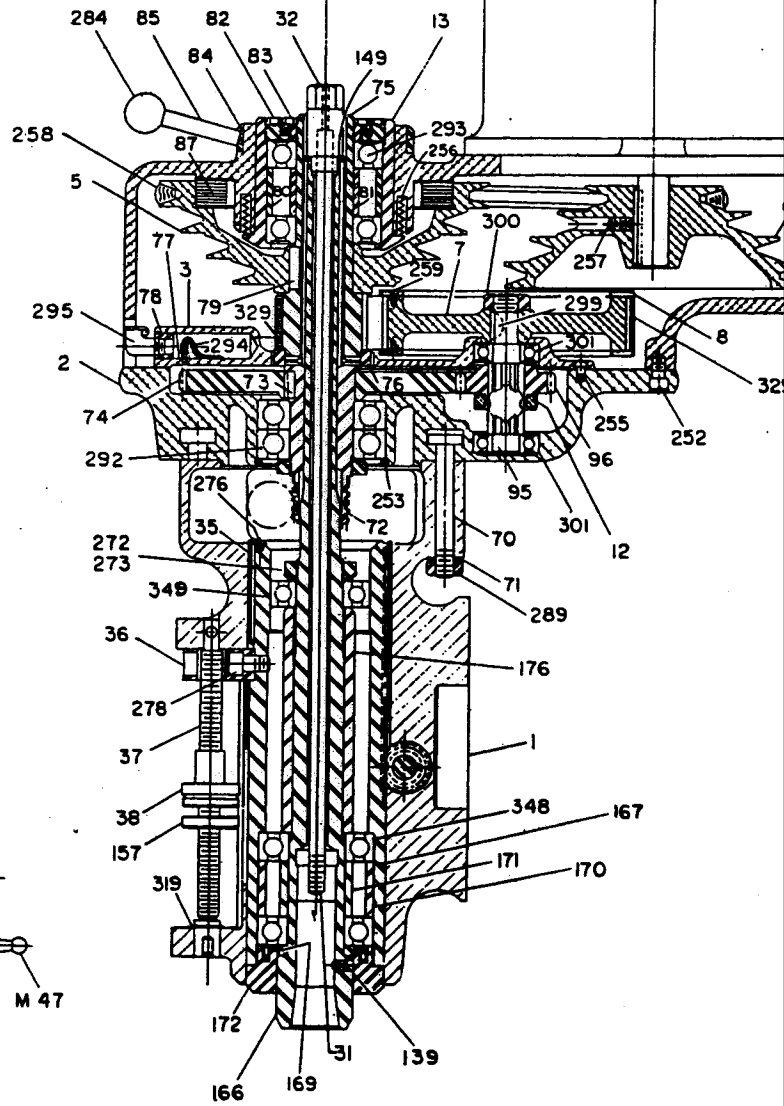
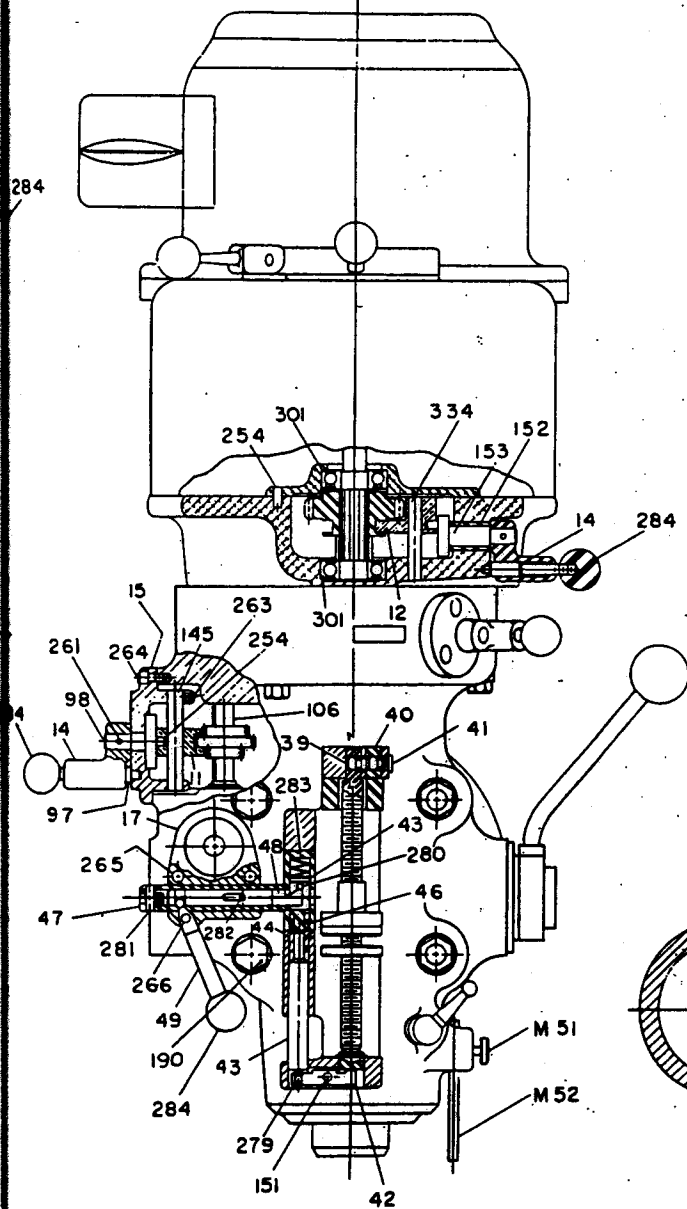
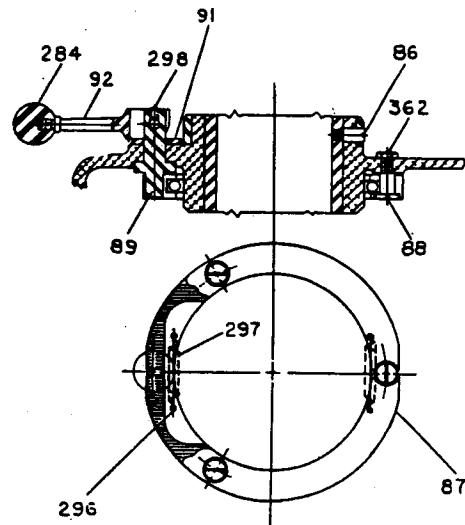
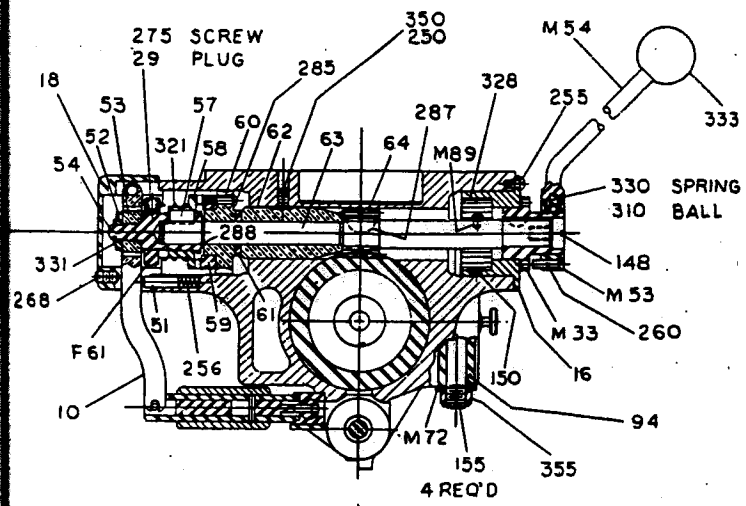

PART LIST — THE BRIDGEPORT TURRET MILLING MACHINE

H-2	ELEVATING SCREW HOUSING	H-103	STOP SCREW
H-3	ELEVATING SCREW NUT	H-104	KEY PIN
H-4	3/8 - 16 x 1 HOLLOW HEAD CAP SCREW (2 REQUIRED)	H-105	SADDLE
H-5	1/4 - 20 x 3/4 HOLLOW HEAD CAP SCREW (3 REQUIRED)	H-106	CROSS FEED NUT
H-6	DOOR	H-107	3/16 x 3/16 x 2-1/2 KEY (2 REQUIRED)
H-7	DOORKNOB	H-108	CROSS FEED NUT RETAINING SCREW (2 REQUIRED)
H-8	DOOR LOCKING CAM	H-109	NO. 8 - 32 x 3/8 WASHER HEAD SCREW (2 REQUIRED)
H-9	1/4 - 20 x 1/4 SET SCREW	H-110	FEED NUT BRACKET
H-10	17/32 x 1 SPACER	H-111	HOLLOW HEAD CAP SCREW (12 REQUIRED)
H-11	3/16 x 1-1/2 HINGE PIN (2 REQUIRED)	H-112	LONGITUDINAL FEED NUT
H-12	WOODEN SHELF (2 HALVES)	H-113	LONGITUDINAL FEED SCREW
H-28	HANDLE	H-114	TABLE
H-50	KNEE (9")	H-115	LEFT BEARING BRACKET
H-263	KNEE (12")	H-117	3/16 x 1 DOWEL PINS (6 REQUIRED)
H-51	ELEVATING SCREW	H-118	RIGHT BEARING BRACKET
H-52	NO. 3606 - J GREASE-SEALED BALL BEARING	H-119	SADDLE-TABLE GIB
H-53	BEARING RETAINER RING	H-120	TABLE LOCK PLUNGER
H-54	1/4 x 20 x 1/2 HOLLOW HEAD CAP SCREW (3 REQUIRED)	H-121	TABLE LOCK BOLT
H-56	3/16 x 3/16 x 7/8 KEY	H-122	TABLE LOCK BOLT HANDLE (2 REQUIRED)
H-57	33/64 x 1 x 0.100 WASHER	H-123	TABLE STOP BRACKET
H-58	1/2 - 20 JAM NUT (2 REQUIRED)	H-124	3/8 - 16 x 1/2 HOLLOW HEAD CAP SCREW (2 REQUIRED)
H-59	BEVEL GEAR	H-125	TABLE STOP PIECE (2 REQUIRED)
H-60	BEVEL PINION	H-126	STOP PIECE T-BOLT (2 REQUIRED)
H-61	NO. 7 WOODRUFF KEY	H-127	WASHER (2 REQUIRED)
H-62	NO. 77020 GREASE-SEALED BALL BEARINGS (3 REQUIRED)	H-128	3/8 - 16 HEXAGON NUT (2 REQUIRED)
H-63	GEAR SHAFT FOR 9" KNEE	H-129	SADDLE-KNEE WIPER PLATE (2 REQUIRED)
H-265	GEAR SHAFT FOR 12" KNEE	H-130	FELT WIPER (4 REQUIRED)
H-64	BEARING CUP	H-131	SADDLE-KNEE GIB
H-65	BEARING RETAINER RING (3 REQUIRED)	H-132	SADDLE LOCK PLUNGER
H-66	1/4 - 20 x 1/2 HOLLOW HEAD CAP SCREW (9 REQUIRED)	H-133	SADDLE LOCK BOLT
H-67	DIAL WITH 100 GRADUATIONS	H-134	NO. 1611 ALEMITE FITTING (2 REQUIRED)
H-68	DIAL HOLDER	H-135	5/16 - 18 x 5/16 SET SCREW
H-69	DIAL LOCK NUT (4 REQUIRED)	H-136	NO. 10 - 32 x 1/2 OVAL HEAD SCREW (6 REQUIRED)
H-70	GEARSHAFT CLUTCH INSERT	H-140	1-1/4 OPEN END AND 1-1/16 BOX END WRENCH
H-71	ELEVATING CRANK	H-141	GREASE GUN
H-75	CROSS FEED SCREW FOR 9" KNEE	H-146	PLUG
H-267	CROSS FEED SCREW FOR 12" KNEE	H-223	TURRET
H-76	NO. XF-12 GREASE-SEALED BALL BEARINGS (2 PAIRS REQUIRED)	H-224	RAM
H-77	CROSS FEED BEARING BRACKET	H-225	RAM ADAPTER
H-78	DIAL WITH 200 GRADUATIONS (3 REQUIRED)	H-226	VERTICAL ADJUSTING WORM
H-79	DIAL HOLDER (3 REQUIRED)	H-227	VERTICAL ADJUSTING WORM SHAFT
H-80	BALL CRANK HANDLE (3 REQUIRED)	H-228	ADAPTER PIVOT STUD
H-81	1/2 - 20 JAM NUT (3 REQUIRED)	H-229	ADAPTER PIVOT STUD LOCKNUT
H-82	3/8 - 16 x 1 HOLLOW HEAD CAP SCREW (4 REQUIRED)	H-230	RAM LOCK STUD
H-83	CHIP GUARD	H-231	RAM PINION
H-84	STOP SCREW	H-232	WORM THRUST WASHER
H-86	3/8 - 16 HEXAGON NUT	H-233	RAM CLAMP
H-87	KNEE COLUMN GIB FOR 9" KNEE	H-234	RAM CLAMP BAR
H-264	KNEE COLUMN GIB FOR 12" KNEE	H-235	WORM KEY
H-88	GIB SCREW (3 REQUIRED)	H-236	ANGLE PLATE
H-89	KNEE LOCKING PLUNGER	H-237	RAM PINION HANDLE
H-90	KNEE LOCKING CAMSHAFT	H-238	RAM PINION SCREW
H-91	5/16 - 18 x 5/16 DOG POINT SET SCREW	H-239	RAM CLAMP
H-92	5/16 - 18 x 5/16 SET SCREW	H-240	ADAPTER LOCKING BOLT (2 REQUIRED)
H-93	CAM SHAFT HUB	H-243	3/8 x 16 BALL
H-94	CAM SHAFT HANDLE	H-254	TURRET
H-95	NO. 1 x 1" TAPER PIN	H-256	SPIDER
H-96	LEFT HAND KNEE-COLUMN WIPER HOLDER	M-72	WASHER
H-97	RIGHT HAND KNEE-COLUMN WIPER HOLDER	H-268	} CHIP GUARD COVER PLATES FOR 12" KNEE
H-98	1/4 - 20 x 1 HOLLOW HEAD CAP SCREW (2 REQUIRED)	H-269	
H-99	FELT WIPER (2 REQUIRED)	H-270	TURRET CLAMP BOLTS
H-100	NO. 1610 ALEMITE FITTING (4 REQUIRED)	H-271	COLUMN

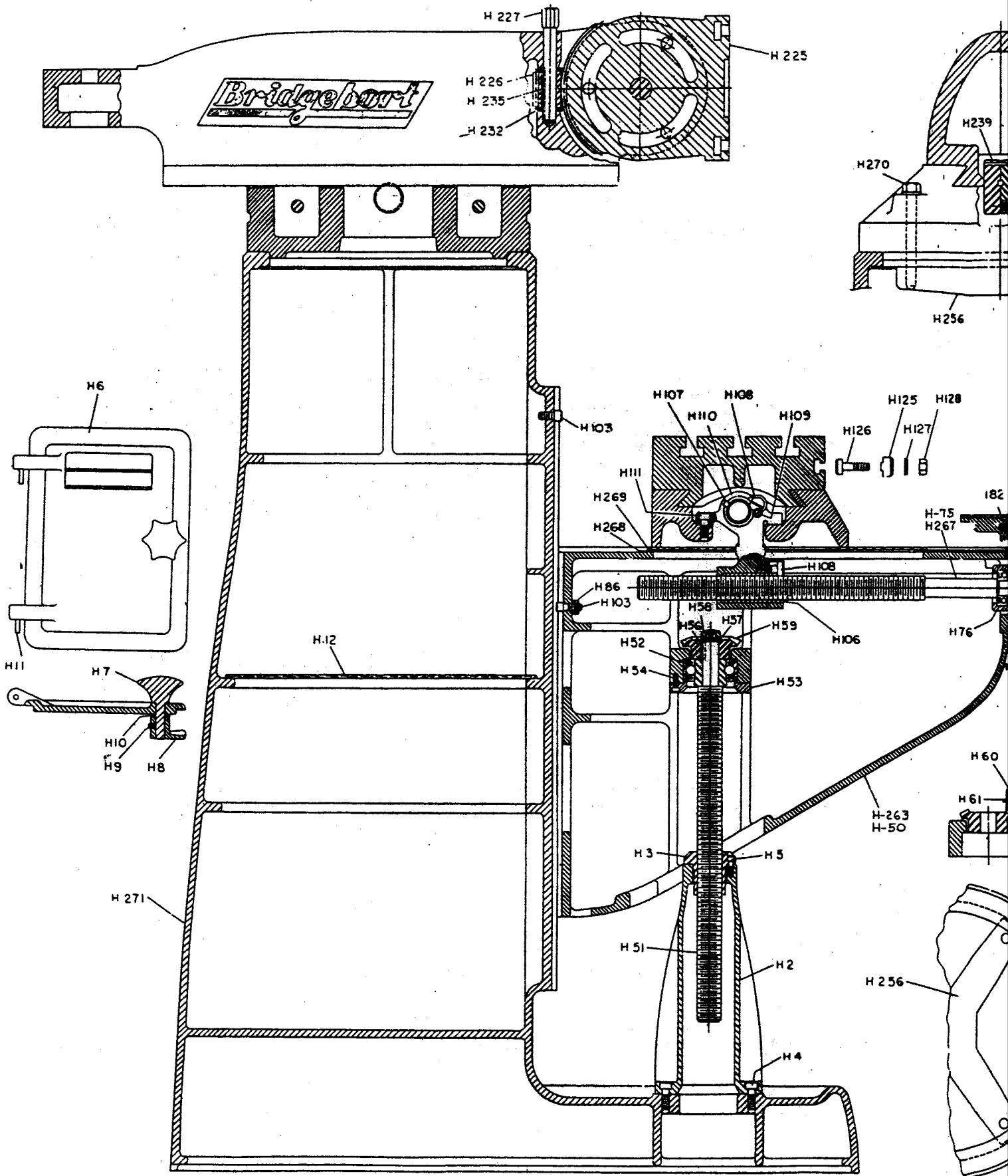

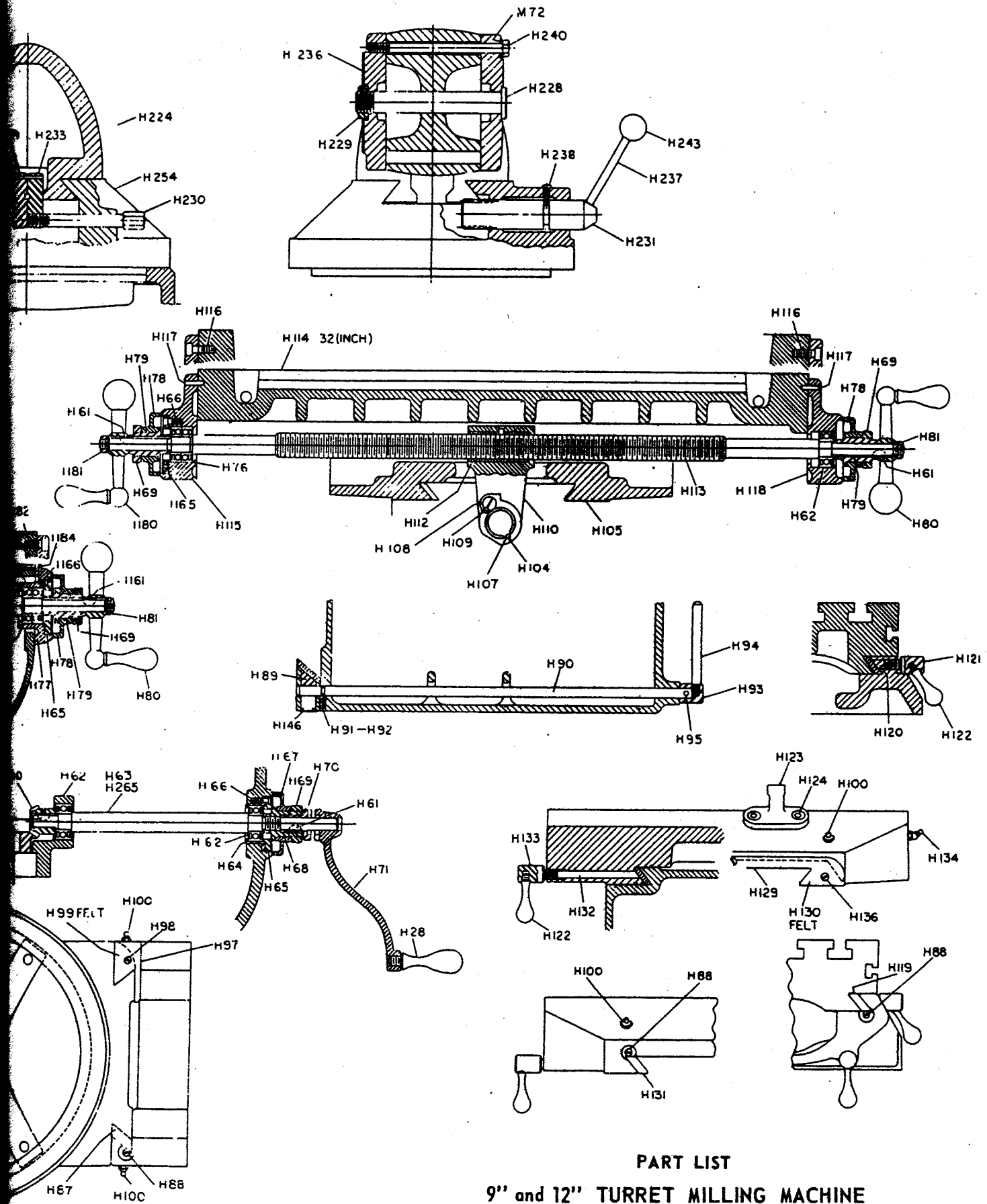

PART LIST

9" and 12" TURRET MILLING MACHINE

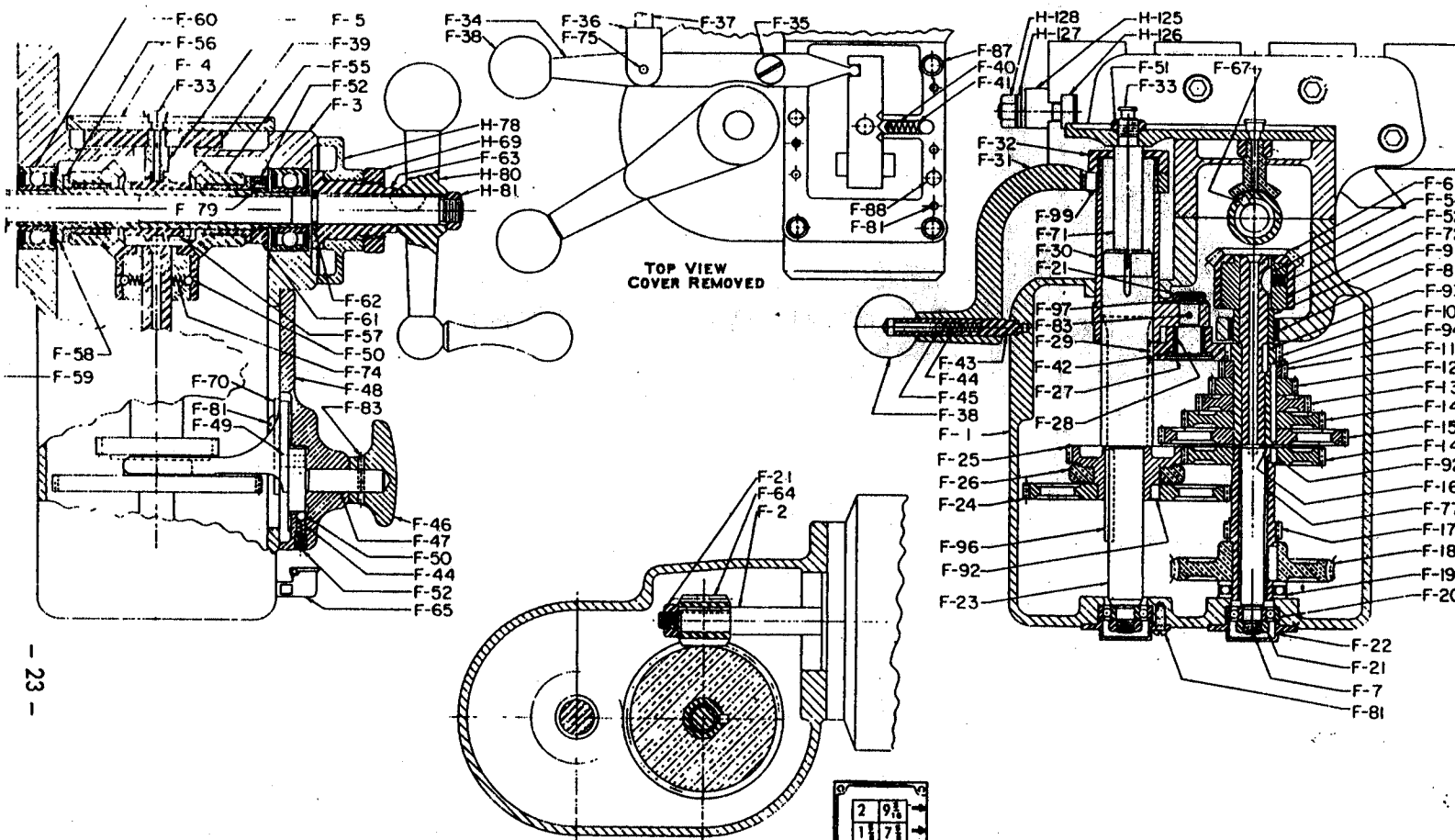

- F-23 16 TOOTH PINION WITH SHAFT
- F-24 70 TOOTH GEAR
- F-25 40 TOOTH GEAR WITH HUB
- F-26 GEAR SHIFTING FORK
- F-27 IDLER STUD
- F-28 NEEDLE BEARING
- F-29 27 TOOTH IDLER GEAR
- F-30 GEAR SHIFTING SLEEVE
- F-31 GEAR SHIFTING HANDLE
- F-32 SHIFTING SLEEVE CAP
- F-33 OILER
- F-34 REVERSING HANDLE
- F-35 PIVOT SCREW
- F-36 REVERSING STOP ROD FORK
- F-37 REVERSING STOP ROD
- F-38 BALL HANDLE
- F-39 REVERSING SLIDE
- F-40 LOCK PIN
- F-41 SPRING 1/4X3/4
- F-42 THRUST WASHER
- F-43 LOCK PIN
- F-44 SPRING
- F-45 PIN
- F-46 SPEED CHANGE KNOB
- F-47 SPEED CHANGE CRANK
- F-48 DOOR
- F-49 PIN
- F-50 BALL
- F-51 HEX. JAM NUT
- F-52 SET SCREW
- F-53 SWITCH
- F-54 NO. 7 WOODRUFF KEY
- F-55 MITER GEAR WITH CLUTCH FACE
- F-56 MOLDED BRONZE BEARING
- F-57 CLUTCH
- F-58 GEAR SLEEVE
- F-59 COTTER (SHEAR) PIN
- F-60 GREASE-SEALED BALL BEARING
- F-61 GEAR SLEEVE NUT
- F-62 SPLIT WASHER
- F-63 DIAL HOLDER
- F-64 WORM
- F-65 OIL CUP
- F-66 CORD SET
- F-67 KEY
- F-68 STOP ROD CLAMP
- F-69 STOP ROD COLLAR
- F-70 SHIFTING FORK HOLD-DOWN
- F-71 SLEEVE GUIDE PIN
- F-72 SAFETY RELEASE INSERT
- F-73 NAMEPLATE
- F-74 SPRING
- F-75 STOP ROD FORK PIN
- F-76 1/4-20 X3/4 SOCKET HD. CAP SCW.
- F-77 MOLDED BRONZE BEARING
- F-78 FEED SCREW
- F-79 BRASS PLUG 3/16X1/16
- F-80 RD. HD. SCREW
- F-81 NO. 10-24X1/2 RD. HD. SCREW
- F-82 PIN 1/4X1/16
- F-83 NO. 00 X1 TAPER PIN
- F-84 TAPER PIN
- F-85 COTTER PIN
- F-86 5/16-18X13/4 SOCKET HD. CAP SCW.
- F-87 5/16-18X2 SOCKET HD. CAP SCW.
- F-88 PIN 5/16X1
- F-89 NO. 10-24X1/2 SOCKET HD. CAP SCW.
- F-90 PIN
- F-91 NO. 10-24X1/4 SET SCREW
- F-92 KEY
- F-93 KEY
- F-94 KEY
- F-95 KEY
- F-96 KEY
- F-97 LOCWASHER
- F-99 KEY
- H-69 DIAL LOCK NUT
- H-78 DIAL
- H-80 BALL CRANK HANDLE
- H-81 1/2-20 JAM NUT
- H-125 TABLE STOP PIECE
- H-126 STOP PIECE T-BOLT
- H-127 WASHER
- H-128 3/8-16 HEXAGON NUT

**PART LIST
POWER FEED ATTACHMENT**

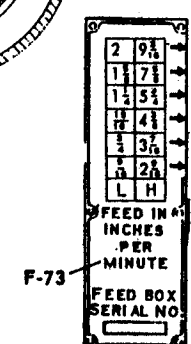

**NOTE: GIVE SERIAL NUMBER
WHEN ORDERING PARTS**

Drawing 10

- F-1 HOUSING
- F-2 MOTOR: 1/8 H.P., 1723 R.P.M.
- F-3 BRACKET
- F-4 COVER PLATE
- F-5 REVERSING FORK
- F-6 MITER GEAR
- F-7 GEAR SHAFT
- F-8 NEEDLE BEARING
- F-9 BEARING INNER RACE
- F-10 18 TOOTH GEAR WITH HUB
- F-11 22 TOOTH GEAR
- F-12 29 TOOTH GEAR
- F-13 38 TOOTH GEAR
- F-14 48 TOOTH GEAR
- F-15 64 TOOTH GEAR
- F-16 FIBER WASHER
- F-17 18 TOOTH SLEEVE GEAR
- F-18 WORM GEAR
- F-19 THRUST BEARING
- F-20 S.A.E. NO. 200 BALL BEARING
- F-21 HEX. JAM NUT
- F-22 BEARING COVER

PART LIST -- MASTER MILLING ATTACHMENT

- M1 QUILL HOUSING
- M2A BELT HOUSING, SINGLE BELT DRIVE, 60
- M2B BELT HOUSING, DOUBLE BELT DRIVE, 60
- M2C BELT HOUSING, SINGLE BELT DRIVE, 25
- M2D BELT HOUSING, DOUBLE BELT DRIVE, 25
- M3 QUILL
- M4A SPINDLE, SINGLE BELT NO.2 MORSE TAPER
- M4B SPINDLE, SINGLE BELT, NO.7 B&S TAPER
- M4C SPINDLE, SINGLE BELT, NO. B3 TAPER
- M4D SPINDLE, DOUBLE BELT, NO.2 MORSE TAPER
- M4E SPINDLE, DOUBLE BELT, NO.7 B&S TAPER
- M4F SPINDLE, DOUBLE BELT, NO. B3 TAPER
- M5 NOSEPIECE
- M6 OIL SLINGER
- M7 S.A.E. NO. 205 BALL BEARING, 4 REQ'D.
- M8 0.750 INSIDE BEARING SPACER
- M9 0.750 OUTSIDE BEARING SPACER
- M10 LONG SPACER
- M11 0.375 INSIDE BEARING SPACER
- M12 0.375 OUTSIDE BEARING SPACER
- M13 NO. W-05 BEARING LOCK WASHER
- M14 NO. N-05 BEARING LOCK NUT
- M15 NO. W-06 BEARING LOCK WASHER
- M16 NO. N-06 BEARING LOCK NUT
- M17A SPINDLE PULLEY HUB, SINGLE BELT DRIVE
- M17B SPINDLE PULLEY HUB, DOUBLE BELT DRIVE
- M18A SPINDLE PULLEY, SINGLE BELT DRIVE
- M18B SPINDLE PULLEY, DOUBLE BELT DRIVE
- M19 S.A.E. NO. 205 BALL BEARING, 2 REQ'D.
- M20 BEARING HOUSING
- M21 BEARING RETAINER RING
- M22 MICROMETER STOP
- M23 MICROMETER NUT
- M24 MICROMETER LOCK NUT

- M25 MICROMETER SCREW
- M26 DRAWBAR NUT (LEFT HAND THREAD)
- M27A DRAWBAR, DOUBLE BELT, NO.7 OR NO.2 SPINDLE
- M27B DRAWBAR, DOUBLE BELT, NO. B3 SPINDLE
- M27C DRAWBAR, SINGLE BELT, NO.7 OR NO.2 SPINDLE
- M27D DRAWBAR, SINGLE BELT, NO. B3 SPINDLE
- *M28 DRAWBAR KNOB
- M30 A MOTOR PULLEY, SINGLE BELT DRIVE
- M30 B MOTOR PULLEY, DOUBLE BELT DRIVE
- *M31 MOTOR PULLEY HUB
- M32 QUILL FEED CLUTCH BOLT
- M33 QUILL FEED CLUTCH HUB
- M34 QUILL FEED PINION
- M35 QUILL FEED WORM WHEEL
- M36 FIBRE WASHER, 2 REQ'D
- M37 SPLIT BUSHING
- M38 CLOCK SPRING
- M39 SPRING COVER
- M40 QUILL FEED CLUTCH KNOB
- M41 MICROMETER SCALE
- M42 QUILL WORM FEED HAND WHEEL
- M43 QUILL WORM FEED HAND WHEEL HANDLE
- M44 QUILL WORM FEED HAND WHEEL HUB
- M45 QUILL FEED WORM HUB
- M46 QUILL FEED WORM
- M47 QUILL LOCK BOLT HANDLE
- M48 QUILL LOCK BOLT
- M49 QUILL LOCK SLEEVE DRILLED
- M50 QUILL LOCK SLEEVE, TAPPED
- M51 INDICATOR ROD CLAMP SCREW
- M52 INDICATOR ROD
- M53 RACK FEED HANDLE HUB
- M54 RACK FEED HANDLE
- M55 BRONZE WORM BUSHING
- M56 GITS NO. 2551 OIL CUP
- M57 PINION KEY
- M58 BRASS QUILL SKIRT
- *M59 MOTOR DOME
- *M60 MOTOR SWITCH
- M61 NO. 00X1/2 TAPER PIN

- M61 TAPER PIN
- M62 STRAIGHT PIN
- M63 OUTSIDE SPRING PIN
- M64 T-BOLT, 4 REQ'D.
- M67 SET SCREW
- M68 CAP SCREW
- M69 HEX. HEAD SCREW
- M70 MOTOR MOUNTING RING STUD, 2 REQ'D.
- M73 3/8 X 16 HEX. NUT, 4 REQ'D.
- M74 3/8 X 1/8 X 3/4 CHAMFERED & HARDENED WASHER
- M75 SET SCREW
- M76 FLAT HEAD SCREW, 2 REQ'D.
- M77 FLAT HEAD SCREW, 3 REQ'D.
- M78 STEEL BALL
- M79 SPRING
- M80 SET SCREW
- *M83 1/2 H.P. MOTOR
- M84 PAPER GASKET
- M85 SET SCREW
- M86 V-BELT
- M87 STRAIGHT PIN
- M88 BRASS PLUG
- M89 PINION SPRING PIN
- M90 MOTOR CORD
- M92 STRAIGHT PIN
- M97 STRAIGHT PIN
- M125 SNAP RING

-24-

NOTE: ALWAYS GIVE SERIAL NUMBER OF ATTACHMENT WHEN ORDERING PARTS. SPECIFY MAKE OF MOTOR FOR ITEMS MARKED *

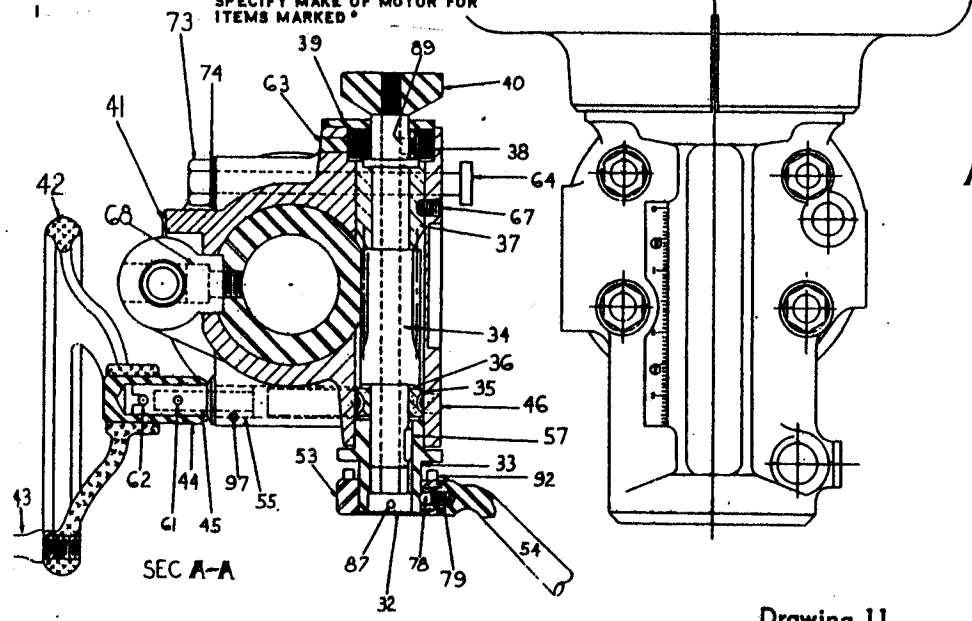

Drawing 11

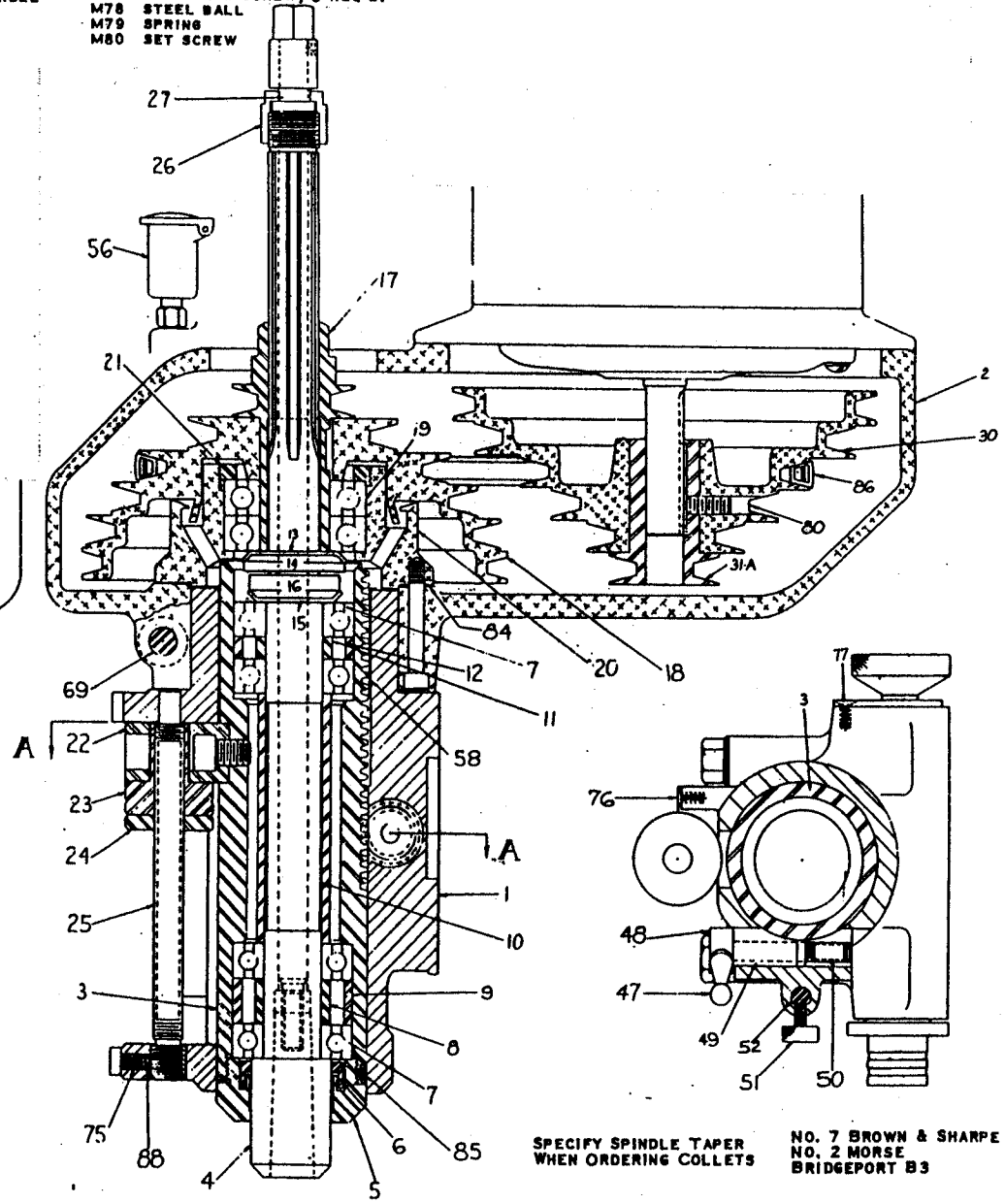

SPECIFY SPINDLE TAPER WHEN ORDERING COLLETS
 NO. 7 BROWN & SHARPE
 NO. 2 MORSE
 BRIDGEPORT B3

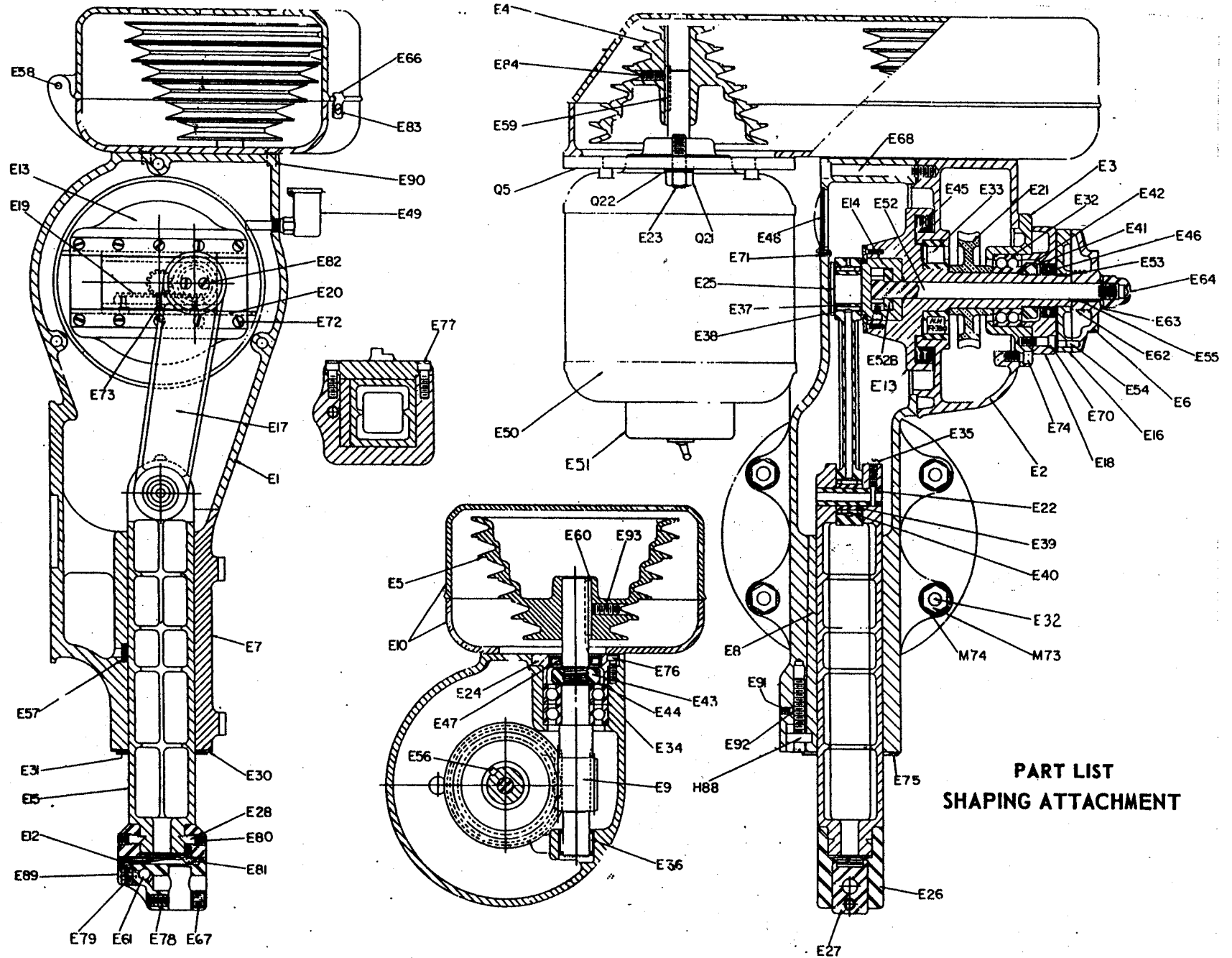

PART LIST -- THE BRIDGEPORT SHAPING ATTACHMENT

E-1	RAM HOUSING	E-53	KEY
E-2	GEAR HOUSING	E-54	3/16 x 3/8 PIN
E-3	GEAR HOUSING COVER	E-55	KEY
E-4*	MOTOR PULLEY	E-56	KEY
E-5	WORM SHAFT PULLEY	E-57	FELT PLUG
E-6	STROKE ADJUSTMENT DIAL	E-58	1/8 x 1-1/4 PIN - 2 REQUIRED
E-7	RAM COVER	E-59	KEY
E-8	GIB	E-60	3/16 x 3/16 x 1-3/4 KEY
E-9	WORM AND SHAFT	E-61	5/16 x 1-7/8 PIN
E-10*	BELT HOUSING	E-62	DIAL SPRING
E-12	CLAPPER SPRING	E-63	WASHER
E-13	CRANK AND SHAFT	E-64	7/16 - 20 ACORN NUT
E-14	CRANKPIN BLOCK	E-66	BELT COVER CLIP
E-15	RAM	E-67	5/16 - 18 x 1/2 SET SCREW
E-16	STROKE ADJUSTMENT PLATE	E-68	5/16 - 18 x 2-3/4 CAP SCREW
E-17	CONNECTING ROD	E-70	1/4 - 20 x 3/4 CAP SCREW - 3 REQUIRED
E-18	CRANK BEARING COVER	E-71	NO. 8-32 x 3/8 WASHER HEAD SCREW - 2 REQUIRED
E-19	RACK	E-72	NO. 10-24 x 3/8 FLAT HEAD SCREW - 10 REQUIRED
E-20	CRANKPIN BLOCK HOLD-DOWN - 2 REQUIRED	E-73	NO. 8-32 x 3/8 ROUND HEAD SCREW - 3 REQUIRED
E-21	WORM GEAR	E-74	1/4 - 20 x 1/2 CAP SCREW - 3 REQUIRED
E-22	RAM CRANKPIN	E-75	NO. 5-40 x 1/4 ROUND HEAD SCREW - 4 REQUIRED
E-23	MOTOR MOUNTING RING STUD - 2 REQUIRED	E-76	NO. 10-24 x 3/8 CAP SCREW - 3 REQUIRED
E-24	WORM BEARING COVER	E-77	1/4 - 20 x 1/2 CAP SCREW - 6 REQUIRED
E-25	BEARING RETAINING WASHER	E-78	5/16 - 18 x 5/8 SET SCREW
E-26	CLAPPER BOX	E-79	5/16 - 18 x 5/8 SET SCREW
E-27	CLAPPER	E-80	5/16 - 18 x 5/16 SET SCREW - 2 REQUIRED
E-28	CLAPPER BOX CLAMP SHOE - 2 REQUIRED	E-81	NO. 8-32 x 3/8 ROUND HEAD SCREW
E-29*	BELT	E-82	NO. 5-40 x 1/4 FLAT HEAD SCREW - 2 REQUIRED
E-30	WIPER PLATE	E-83	NO. 8-32 x 3/8 WASHER HEAD SCREW
E-31	WIPER-FELT	E-84	5/16 - 18 x 5/8 SET SCREW
E-32	NO. 5205 BEARING	E-85	OVERARM MARKER
E-33	NO. R330 BEARING	E-88	1/8 PIPE PLUG, DRILLED AND TAPPED
E-34	NO. 204 BEARING - 1 PAIR	E-89	NO. 10-24 x 1/4 SET SCREW
E-35	RAM CRANKPIN LOCKSCREW	E-90	1/4 - 20 x 1/2 FLAT HEAD SCREW - 4 REQUIRED
E-36	NO. B-1212X BEARING	E-91	1/4 - 20 x 1/4 SET SCREW
E-37	NO. 15-1312 INNER RACE	E-92	BRASS PLUG
E-38	NO. GB-1612X BEARING	E-93	5/16 - 18 x 3/4 SET SCREW
E-39	NO. 15-812 OSC. INNER RACE	E-94	ROTATION NAMEPLATE
E-40	NO. GB-1212X BEARING	E-203	STANDARD NAMEPLATE
E-41	N-05 LOCKNUT	M-73	T-BOLT NUT - 4 REQUIRED
E-42	NO. W-05 LOCKWASHER	M-74	T-BOLT WASHER - 4 REQUIRED
E-43	NO. N-04 LOCKNUT	Q-17	T-BOLT - 4 REQUIRED
E-44	NO. W-04 LOCKWASHER	Q-5	MOTOR MOUNTING RING
E-45	3-1/4 x 4-1/4 x 1/2 OILSEAL	Q-21	MOTOR MOUNTING RING STUD NUT - 2 REQUIRED
E-46	7/8 x 1-1/2 x 3/8 OILSEAL	Q-22	MOTOR MOUNTING RING STUD WASHER - 2 REQUIRED
E-47	3/4 x 1-1/2 x 5/16 OILSEAL	H-88	GIB SCREW
E-48	AIR VENT COVER		
E-49	OIL CUP		
E-50*	MOTOR		
E-51*	SWITCH		
E-52	LOCKING BOLT AND GEAR		
E-52B	LOCKING BOLT COLLAR		

* GIVE MOTOR SPECIFICATIONS INCLUDING MAKE OF MOTOR WHEN ORDERING THESE PARTS. ALWAYS GIVE SERIAL NUMBER OF ATTACHMENT.

CHERRYING ATTACHMENT PARTS LIST

M2 A	Belt Housing, single belt drive, 60 cycle	M90	Motor Cord
M4 D	Spindle, Double belt, #2 Morse Taper	T1	Quill Housing
M4 E	Spindle, Double belt, #7 B&S Taper	T2	Quill Housing Saddle
M5	Nosepiece	T3	Gear Housing
M6	Oil Slinger	T4	Drum Gear
M7	SAE # 205 Ball Bearing (4 Req'd)	T5	Gib (2 Req'd)
M8	0.750 Inside Bearing Spacer	T6	Gib Screw (2 Req'd)
M9	0.750 Outside Bearing Spacer	T7	Gib Screw Washer (2 Req'd)
M10	Long Spacer	T8	Cherry
M11	0.375 Inside Bearing Spacer	T9	Pivot Stud
M12	0.375 Outside Bearing Spacer	T10	Torr. Brg. GB-98
M13	No. W-05 Bearing Lock Washer	T11	Drum Gear Plate
M14	No. N-05 Bearing Lock Nut	T12	Pivot Offset Block
M15	No. W-06 Bearing Lock Washer	T13	Lead Screw
M16	No. N-06 Bearing Lock Nut	T14	Lead Screw Locknut
M17 A	Spindle Pulley Hub, Single Belt Drive	T15	Lead Screw Washer
M18 A	Spindle Pulley, Single Belt Drive	T16	Lead Screw Dial
M19	SAE #206 Ball Bearings (2 Req'd)	T17	Lead Screw Spacer
M20	Bearing Housing	T18	Allen Wrench Stud
M21	Bearing Retainer Ring	T19	Wrench Knob
M26	Drawbar Nut (Left Hand Thread)	T20	10 - 32 x 1/2 lg. Flat Head Screw
M27 A	Drawbar, double drive, #7 or #2 spindle	T21	Zero Block
M28	Drawbar Knob	T22	Handwheel Handle
M29	Motor Mounting Ring	T23	3/8" Star Washer
M30 A	Motor pulley, single belt drive with Hub Part M31	T24	Hand Wheel
M31	Motor Pulley Hub	T25	Hand Wheel Dog
M47	Quill Lock Bolt Handle	T26	Hand Wheel Gear Clutch
M48	Quill Lock Bolt	T27	Hand Wheel Pinion
M49	Quill Lock Sleeve, Drilled	T28	Idler Gear
M50	Quill Lock Sleeve, Tapped	T29	Idler Gear Post
M56	Gits No. 2551 Oil Cup	T30	Lead Screw Zero Pin
M60	Motor Switch 9441 H31D Cutler Hammer	T31	Scale (Purchased)
M64	T Bolts (4 Req'd)	T32	Stop Dog (2 Req'd)
M65	1/4 x 20 x 1-3/4 lg. Cap Screw (6 Req'd)	T33	T Bolt (3 Req'd)
M69	1/2 x 13 x 3-1/4 Hex. Head Screw	T34	T Bolt Washer (3 Req'd)
M70	Motor Mounting Ring Stud (2 Req'd)	T35	Dial Binder Plug
M71	1/2 x 20 Hex. Nut (2 Req'd)	T36	Fork Adapter (See Misc. Price List)
M72	1/2 x 1/8 x 1 Chamfered & Hardened Washer	T37	Finger Ratchet Spring
M83	1/2 HP Motor	T38	Feed Ratchet Dog
M84	Paper Gasket	T39	Ratchet Stud
M85	1/4 x 20 x 1/4 Set Screw	T40	Ratchet Dog Tee Bolt
M86	Gilmer 5607 Belt F.H.P.	T41	Adapter Tee Bolt
		T45	Quill

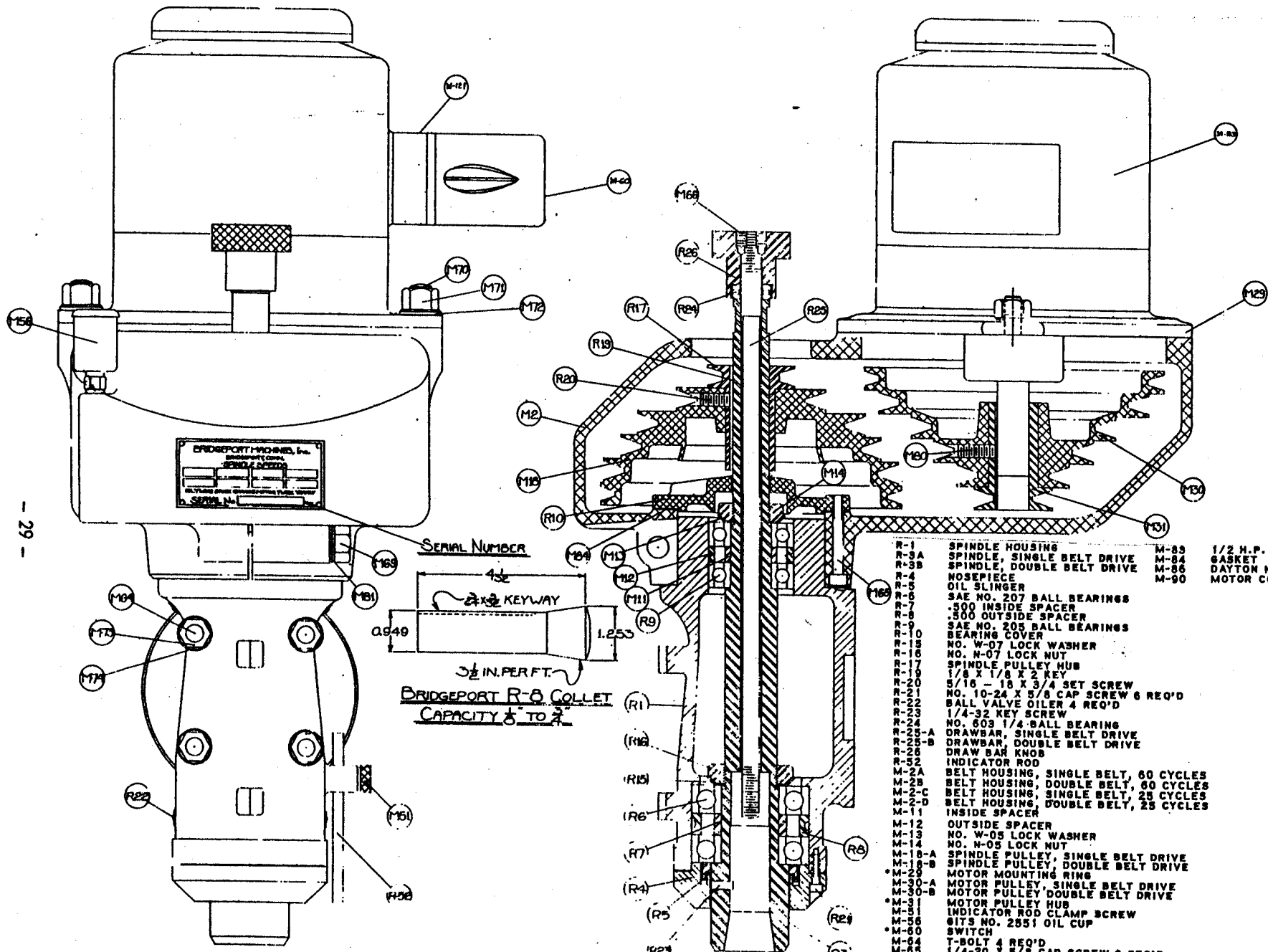

- 29 -

PART LIST
MODEL "R" MILLING ATTACHMENT

Drawing 14

- | | | | |
|--------|--|------|-------------------------------|
| R-1 | SPINDLE HOUSING | M-83 | 1/2 H.P. MOTOR |
| R-3A | SPINDLE, SINGLE BELT DRIVE | M-84 | GASKET |
| R-3B | SPINDLE, DOUBLE BELT DRIVE | M-86 | DAYTON NO. 1029 F.H.P. V-BELT |
| R-4 | NOSEPIECE | M-90 | MOTOR CORD SET |
| R-5 | OIL SLINGER | | |
| R-6 | SAE NO. 207 BALL BEARINGS | | |
| R-7 | .500 INSIDE SPACER | | |
| R-8 | .500 OUTSIDE SPACER | | |
| R-9 | SAE NO. 205 BALL BEARINGS | | |
| R-10 | BEARING COVER | | |
| R-13 | NO. W-07 LOCK WASHER | | |
| R-14 | NO. W-07 LOCK NUT | | |
| R-17 | SPINDLE PULLEY HUB | | |
| R-19 | 1/8 X 1/8 X 2 KEY | | |
| R-20 | 5/16 - 18 X 3/4 SET SCREW | | |
| R-21 | NO. 10-24 X 5/8 CAP SCREW 6 REQ'D | | |
| R-22 | BALL VALVE OILER 4 REQ'D | | |
| R-23 | 1/4-32 KEY SCREW | | |
| R-24 | NO. 603 1/4 BALL BEARING | | |
| R-25-A | DRAWBAR, SINGLE BELT DRIVE | | |
| R-25-B | DRAWBAR, DOUBLE BELT DRIVE | | |
| R-26 | DRAW BAR KNOB | | |
| R-52 | INDICATOR ROD | | |
| M-2A | BELT HOUSING, SINGLE BELT, 60 CYCLES | | |
| M-2B | BELT HOUSING, DOUBLE BELT, 60 CYCLES | | |
| M-2C | BELT HOUSING, SINGLE BELT, 25 CYCLES | | |
| M-2D | BELT HOUSING, DOUBLE BELT, 25 CYCLES | | |
| M-11 | INSIDE SPACER | | |
| M-12 | OUTSIDE SPACER | | |
| M-13 | NO. W-05 LOCK WASHER | | |
| M-14 | NO. W-05 LOCK NUT | | |
| M-18-A | SPINDLE PULLEY, SINGLE BELT DRIVE | | |
| M-18-B | SPINDLE PULLEY, DOUBLE BELT DRIVE | | |
| M-25 | MOTOR MOUNTING RING | | |
| M-30-A | MOTOR PULLEY, SINGLE BELT DRIVE | | |
| M-30-B | MOTOR PULLEY, DOUBLE BELT DRIVE | | |
| M-31 | MOTOR PULLEY HUB | | |
| M-51 | INDICATOR ROD CLAMP SCREW | | |
| M-56 | 6ITS NO. 2551 OIL CUP | | |
| M-60 | SWITCH | | |
| M-61 | T-BOLT 4 REQ'D | | |
| M-62 | 1/4-20 X 5/8 CAP SCREW 3 REQ'D | | |
| M-66 | 1/4-20 X 3/8 SET SCREW 4 REQ'D | | |
| M-69 | 1/2-13 X 3-1/4 HEX HEAD SCREW | | |
| M-70 | MOTOR MOUNTING RING STUD 2 REQ'D | | |
| M-71 | 1/2-20 HEX. HD. NUT 2 REQ'D | | |
| M-72 | 1/2 X 1/8 X 1 HARDENED, CHAMFERED WASHER | | |
| M-73 | 3/8-16 HEX NO. 7 4 REQ'D | | |
| M-74 | 3/8 X 1/8 X 3/4 HARDENED, CHAMFERED WASHER | | |
| M-80 | 5/16 - 18 X 3/4 SET SCREW | | |
| M-81 | 1/2 X 1/8 X 7/8 HARDENED, CHAMFERED WASHER | | |

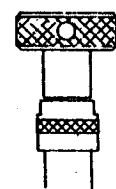
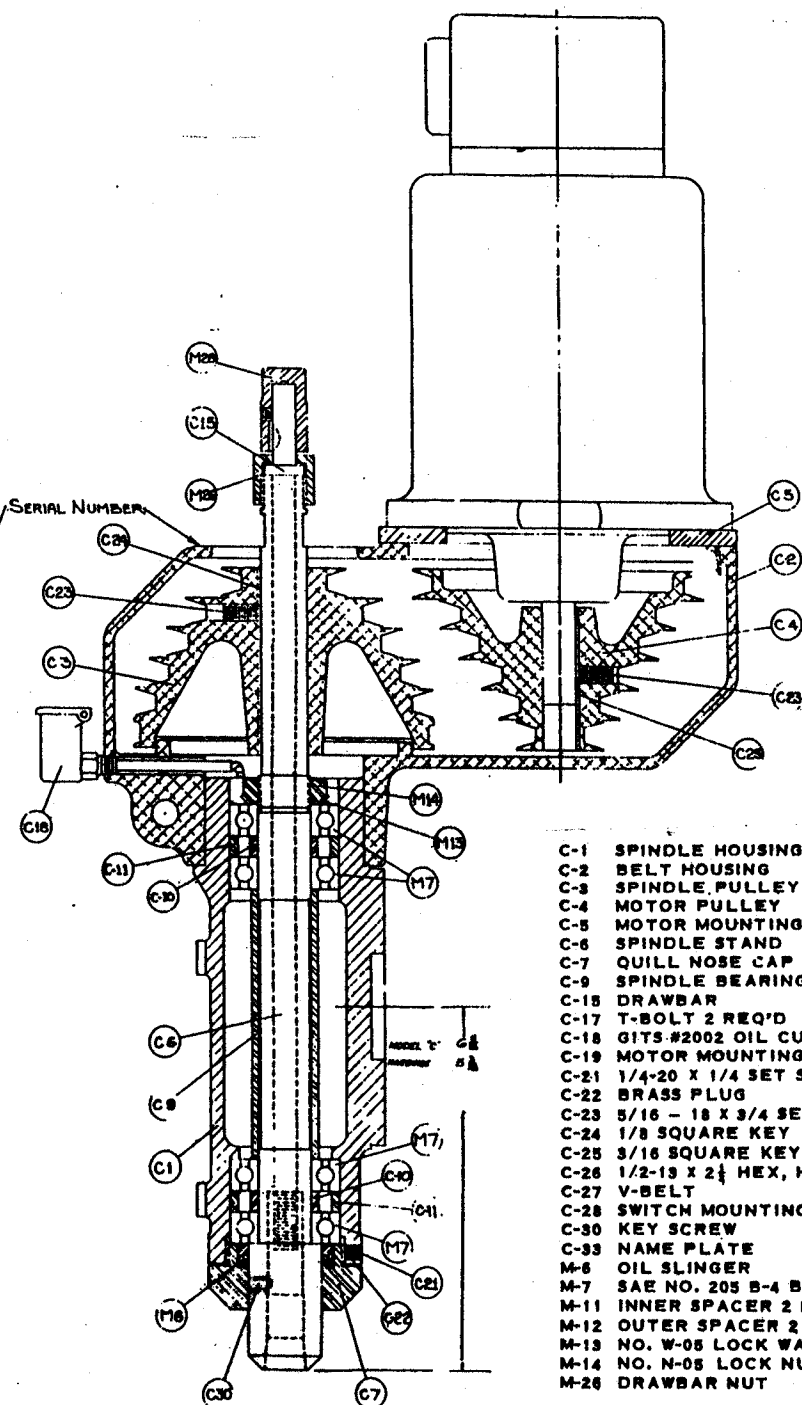
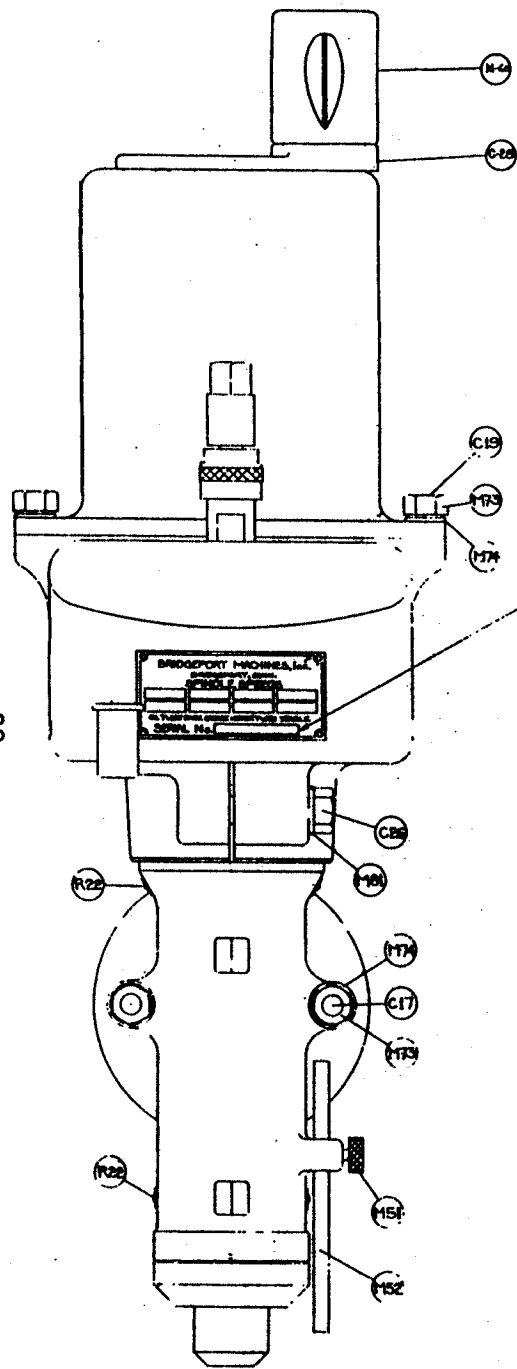

NOTE: KNURLED TYPE & DRAW
KNURLED KNOB TYPE DRAWBAR
COMPLETE DRAWBAR ASSEMBLY
(AND M-26) WILL BE REPLACED
KNOB DRAWBAR ASSEMBLY.

- | | | | |
|------|---------------------------------------|------|--------------------------------|
| C-1 | SPINDLE HOUSING | M-28 | DRAWBAR KNOB |
| C-2 | BELT HOUSING | M-51 | INDICATOR ROD CLAMP SCREW |
| C-3 | SPINDLE PULLEY | M-52 | INDICATOR ROD |
| C-4 | MOTOR PULLEY | M-60 | MOTOR SWITCH |
| C-5 | MOTOR MOUNTING RING | M-73 | 3/8 - 16 HEX. NUT 4 REQ'D |
| C-6 | SPINDLE STAND | M-74 | 3/8 X 1/8 X 3/4 WASHER 4 REQ'D |
| C-7 | QUILL NOSE CAP | M-81 | 1/2 X 1/8 X 7/8 WASHER |
| C-9 | SPINDLE BEARING SPACER | R-22 | BALL VALVE OILER 4 REQ'D |
| C-15 | DRAWBAR | | |
| C-17 | T-BOLT 2 REQ'D | | |
| C-18 | GITS #2002 OIL CUP, TUBING, WICK | | |
| C-19 | MOTOR MOUNTING RING STUD 2 REQ'D | | |
| C-21 | 1/4-20 X 1/4 SET SCREW | | |
| C-22 | BRASS PLUG | | |
| C-23 | 5/16 - 18 X 3/4 SET SCREW 2 REQ'D | | |
| C-24 | 1/8 SQUARE KEY | | |
| C-25 | 3/16 SQUARE KEY | | |
| C-26 | 1/2-19 X 2 1/2 HEX, HEAD SCREW | | |
| C-27 | V-BELT | | |
| C-28 | SWITCH MOUNTING BRACKET | | |
| C-30 | KEY SCREW | | |
| C-33 | NAME PLATE | | |
| M-6 | OIL SLINGER | | |
| M-7 | SAE NO. 205 B-4 BALL BEARINGS 4 REQ'D | | |
| M-11 | INNER SPACER 2 REQ'D | | |
| M-12 | OUTER SPACER 2 REQ'D | | |
| M-13 | NO. W-05 LOCK WASHER | | |
| M-14 | NO. N-05 LOCK NUT | | |
| M-26 | DRAWBAR NUT | | |

Drawing 15

OPTICAL MEASURING SYSTEM

Alignment of Scales.

Table Scale

1. Install scale holder (0-7) on scale holder bracket (0-21) using (2) washers (0-60) and (2) round head screws (0-41). Snug up screws (0-41).
2. Loosen (4) screws (0-40) located in base of scope housing (0-2). Move scope unit (0-2) in or out to bring image in focus on window of scope unit (0-2). Snug up (2) screws (0-40) (top left and lower right) in base of scope unit (0-2).
3. Crank table to read 5.000 inch in scope unit window. At this point lower or raise scale holder (0-7) by using adjustment screw (0-48) to bring scale image into view of scope unit window so that the top of the short graduations lines are parallel to top of catch fork.

(Note: Illustration.)

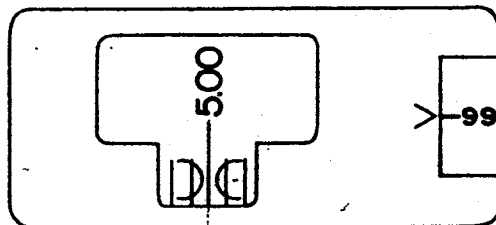

FIG. 3

4. Follow same procedure at point 15 inch on scale image viewed in scope unit window. This adjustment is repeated until scale graduations are parallel to catch fork. Re-adjust scope housing for sharpness and lock scope housing tight by using (4) screws (0-40). Re-check scale image in scope unit window and make final adjustment on scale holder (0-7) if necessary. Lock (2) screws (0-41) tight. Check tenth reading dial to scale graduations. (This reading will determine proper focus of scope — i.e. scope must be adjusted in or out for proper focus.) Dial reading should be set at 99 and catch fork lined central with a given line by moving the machine lead screw. See Fig. 3. Rotate dial to line below 0 line — catch fork should now fall centrally over adjacent line. If it doesn't, then the focus of the scope must be adjusted.

Note: This is most important as unit is *only* in focus when lines are in center of catch and fork as described above.

Cross Travel Scale

1. Crank saddle to front position.
2. Loosen (4) screws (0-40) located in base of scope unit (0-2). Position scope unit (0-2) so location of screws (0-40) are in center of elongated slots. Snug up (2) screws (0-40) in scope unit.
3. Bring scale into focus by using adjusting nut (0-17). Align short graduations to top of catch fork.
4. Crank table to 9" or 12" point on scale. Bring scale to focus by adjusting nut (0-17) and set top of catch fork to top of short graduations using adjusting set screw (0-48). Proceed to focus following same procedure in setting table scale holder (0-7).

Note: Check 1" slide adjustment for parallelism. If top of catch fork does not run parallel to top of short graduations. It is necessary to loosen (4) cap screws (0-53) holding cross bracket-lens assembly (0-3) and make proper adjustment.

OPTICAL PARTS DRAWING

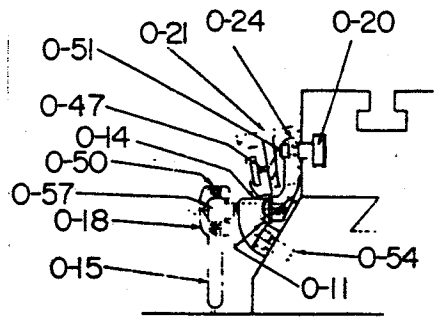
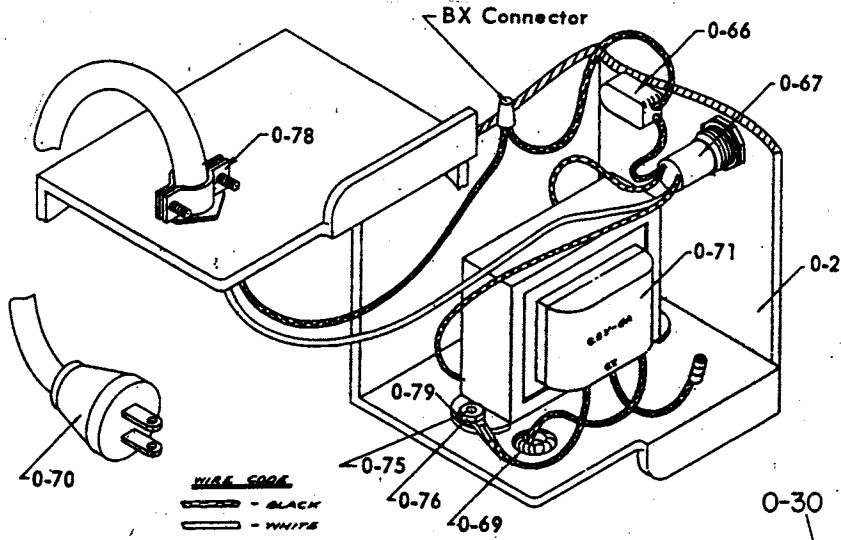

WIRE CODE
 ———— - BLACK
 ———— - WHITE

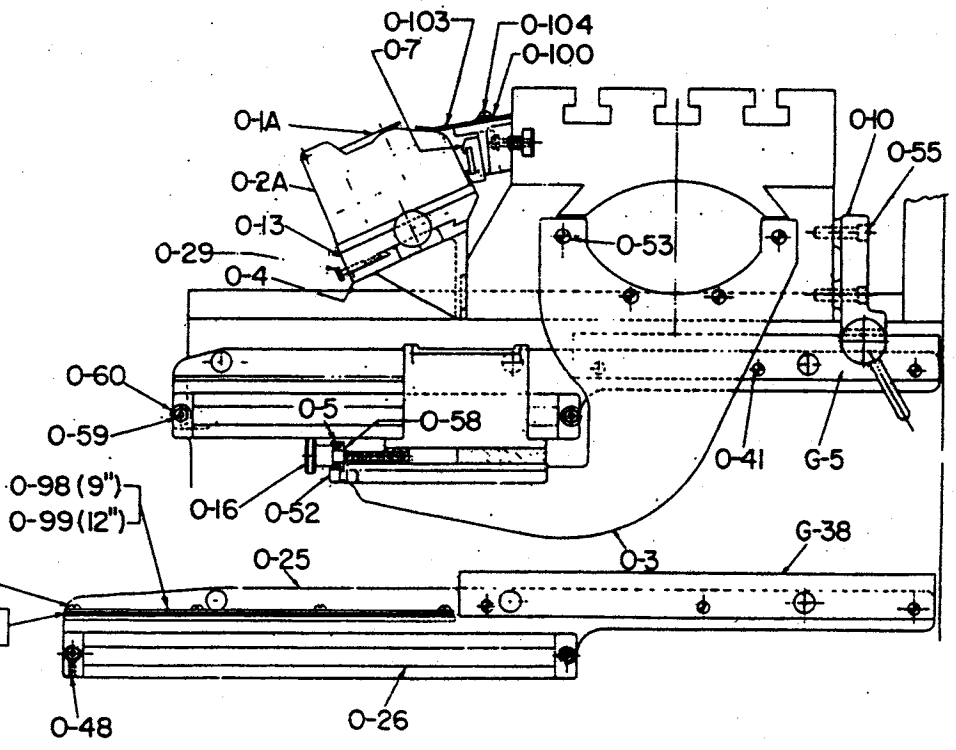
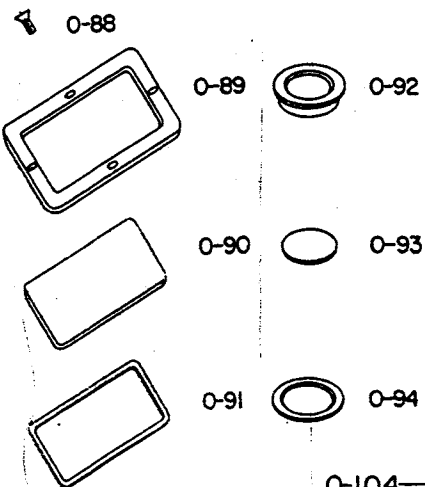
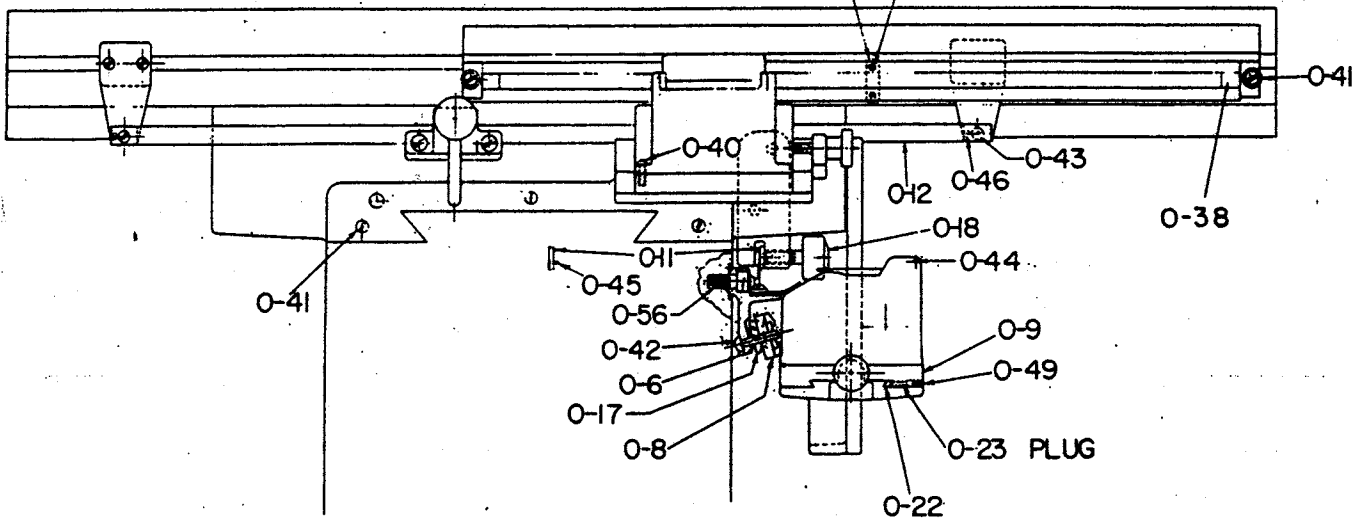

OPTICAL PARTS LIST

PART NUMBER	AMOUNT	NAME
O-1A		Lens Cover
O-2A		Scope Housing
O-3	1	Cross Bracket
O-4	1	Table Bracket
O-5	2	Adj. Screw Bracket
O-6	1	9" Cross Travel Bracket
O-7	1	Table Scale Bracket
O-8	1	9" Cross Travel Scale Bracket
O-9	1	Cross Travel Dovetail Slide
O-10	1	Cross Travel Binder Bracket
O-11	2	Binding Bracket Plate
O-12	1	Table Binder Strip
O-13	1	Table Dovetail Slide
O-14	1	Table Binder Bracket
O-15	2	Binder Handle
O-16	2	Housing Adjusting Screw
O-17	2	Scale Adj. Nut
O-18	2	Binder Hub
O-20	7	Tee Slot Shoe
O-21	1	Table Scale Bracket
O-22	2	Straight Dovetail Gib
O-23	6	Gib Binding Plugs
O-24	2	Binding Strip Dogs
O-25	1	12" Cross Travel Bracket
O-26	1	12" Cross Travel Scale Bracket
O-27		Assembly Dwgs.
O-28	1	Transformer Box
O-29	2	Slide Lock Screw
O-30	1	Scale Holder Clamp
O-31	1	Cam Shaft (Not Shown)
O-32	1	Scale Dial Knob (Not Shown)
O-33	1	Dial Knob Shaft (Not Shown)
O-34	1	Dial Knob Washer (Not Shown)
O-35	1	Lamp Cover Gasket (Not Shown)
O-36	1	Lens Cover Gasket (Not Shown)
O-37	1	Dial Knob Shaft Diaphragm (Not Shown)
O-38	4	Scale Holder Cap (Replaces O-19)
O-39	2	Scope Units Complete
O-40	8	8-32 x 1/2 Round Head Screws
O-41	8	10-32 x 1/2 Round Head Screws
O-42	2	Round Head Screws
O-43	2	1/4-20 x 3/8 Round Head Screws
O-44	4	.078" x 3/8 Roll Pins
O-45	4	1/8 x 1/4 Roll Pins
O-46	2	1/8 x 3/8 Roll Pins
O-47	4	5-40 x 1/8 Socket Set Screws
O-48	4	5-40 x 1/2 Socket Set Screws
O-49	4	6-40 x 3/8 Socket Set Screws
O-50	2	1/4-28 x 1/4 Socket Set Screws
O-51	7	10-32 x 3/4 Socket Cap Screws
O-52	4	1/4-20 x 1/2 Socket Cap Screws
O-53	4	1/4-20 x 3/4 Socket Cap Screws
O-54	2	5/16-18 x 5/8 Socket Cap Screws
O-55	2	5/16-18 x 1" Socket Cap Screws
O-56	3	3/8-16 x 3/4 Socket Cap Screws
O-57	2	3/8-16 x 1 Socket Cap Screws
O-58	2	#5100-31 Snap Ring
O-59	2	10-32 Hex Nut
O-60	4	#6 Flat Washer
O-61	1	9" Scale
O-62	1	12" Scale
O-63	1	20" Scale
O-64	2	Bycor Cord Seal (Specify Scale Length)
O-65	2	Scale Glass (Specify Scale Length)
O-66	1	Toggle Switch (117/110 Volt)
O-67	1	Signal Lamp Complete (117/110 Volt)
O-68	1	Signal Lamp Bulb GE NE 51H (117/110 Volt)
O-69	1	Rubber Cromet. 3/8 I.D.
O-70	1	Cord Set (18-2 117/110 Volt)
O-71	1	Transformer (117/110 Volt Primary - 6.3 Volt Secondary)
O-72	1	Harness Cord Set (6.3 Volt)
O-73	1	Transformer Box Name Plate
O-74	2	Decal (Optical Housing)
O-75	2	6-32 x 1/2 Round Head Screws
O-76	2	6-32 Hex Nuts
O-77	2	1/4-20 x 1/2 Round Head Screws
O-78	1	3/8" Cable Connector
O-79	1	#B65 Spade Terminal
O-80	1	#2B-14 Wire Terminal
O-81	2	Bulb #81 Automotive (6 Volt)
O-82	1	1/2-13 x 3/8 Socket Set Screws
O-83	1	67-1/2° Angle Alemite Fitting
O-84	1	Starr Lenn Gauze
O-85	2	5-40 x 1" Oval Head Screw
O-86	2	No. 4 x 1/4 R Sheet Metal Screws
O-87	2	Rubber Cap
O-88		#1-72 x 3/16 Flat Head Screw for Window Frame
O-89	2	Window Frame
O-90	2	Window
O-91	2	Window Gasket
O-92	2	Lens Frame
O-93	2	Lens
O-94	2	Lens Gasket
O-98		Guard Securing Strip (9" Knee)
O-99		Guard Securing Strip (12" Knee)
O-100		Guard Securing Strip (Table)
O-101		Cross Travel Scale Guard (9" Knee)
O-102		Cross Travel Scale Guard (12" Knee)
O-103		Table Scale Guard
O-104		6-32 x 1/4 LG. RD. HD. Mach. Screw
OF-79	1	Table Stop Bracket (P.F.)
OF-80	1	Power Feed Stop Rod (Give Table Size)
OF-81	1	Power Feed Reversing Stop Rod Guide
OF-82	1	Table Binder Strip (With Power Feed)
OF-107		Power Feed Binder & Rod Bracket
OF-108		Power Feed Control Lever for Offset Stud
OF-109		Power Feed Offset Stud
G-5	1	9" Saddle Locking Strip
G-38	1	12" Saddle Locking Strip