

SECTION

I	Page	<u>INSTALLATION</u>
	1.1	Handling
	1.2	Cleaning
	1.3	Floor Plan
	1.4	Foundation Power Supply
	1.5	Initial Setting Anciliary Equipment
II		<u>OPERATION</u>
	2.1	Machine Controls
	2.2	J-Head Controls
	2.3	2J2-Head Controls
	2.4	Mechanical Table Feed
	2.5	Infinitely Variable Table Feed
	2.6	M-Head Controls
	2.7	E-Head Controls
	2.8	Heidenhain Digital Read Out VRZ 7 10
III		<u>LUBRICATION</u>
	3.1	Basic Machine
	3.2	J-Head
	3.3	2J2-Head
	3.4	Feed Boxes
	3.5	M and E-Head
IV		<u>MAINTENANCE</u>
		GENERAL
	4.1	Table Screw Assembly
	4.2	Cross Screw Assembly
	4.3	Gib Strip Adjustment
		J-HEAD
	4.4	Belt Replacement Brake Shoe Replacement
	4.5	Balance Spring Replacement Feed Trip Adjustment
	4.6	Collet Aligning Screw
	4.7	Quill Removal
		2J2-HEAD
	4.8	Motor Removal
	4.9	Belt Replacement
	4.10	Brake Shoe Replacement

SECTION

IV

Page MAINTENANCE (contd)

M-HEAD

4.11 Vee Belt Replacement

4.12 Quill Removal

E-HEAD

4.13 Removing Motor

Changing Speed

Removing Reduction Drive Unit or Ram

Changing the Gearcase Oil

V

SPECIFICATION AND EXTRA EQUIPMENT

5.1 Bridgeport BRJ

5.2 Bridgeport BRJ-Head

5.3 Bridgeport BR2J2

5.4 Bridgeport BR2J2-Head

5.5 Bridgeport BRM

5.6 Bridgeport BRM-Head

5.7 Bridgeport E-Head

5.8 Extra Equipment

VI

SPARE PARTS DRAWINGS & PARTS LISTS

6.1 Basic Machine

6.2 Leadscrew

6.3 J-Head Top Housing

6.4 J-Head, J-1 Assembly

6.5 2J2-Head Top Housing

6.6 2J2-Head Back Gear

6.7 6F Longitudinal Varifeed Box

6.8 6F Gross Varifeed Box

6.9 E-Head

6.10 M-Head

6.11 Lubrication System

6.12 Heidenhain Digital Read Out VRZ 710

6.13 Additional Manuals Available

6.14 Additional Information

VII

ELECTRICAL SCHEMATIC DIAGRAM

7.1 Electrical Panel for use with Feedbox

7.2 Panel 3 for Longitudinal & Cross Feed (English)

7.3 Bridgeport Fitted with Standard Panel 3 Longitudinal/
Cross Feed Type WD 153/D

7.4 Wiring Layout for Digital Read-Out WD 156/B

NOTES



Installation

WEIGHT

Basic machine approximately 2200 lb (997 kg)

METHOD 1

Insert $\frac{3}{4}$ " Whitworth eye bolt in tapped hole. Ensure bolt is fully secured before lifting. It is advisable to swivel head before lifting machine.

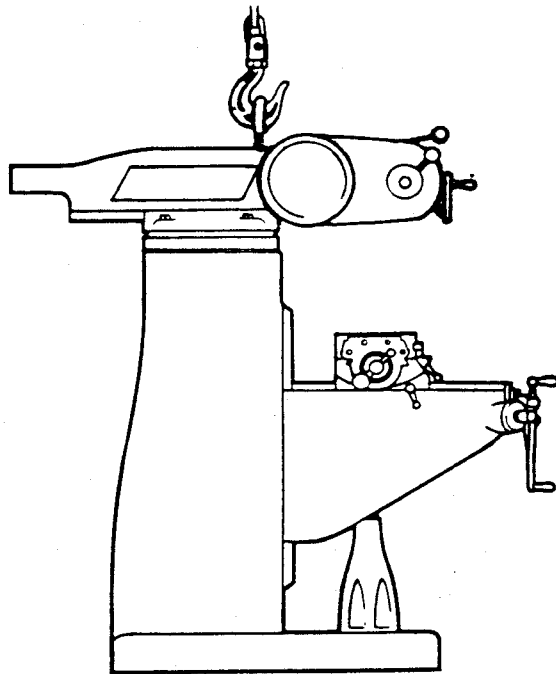

METHOD 2

Use rope sling as illustrated. Insert pads of soft cloth between rope and machined edges. It is advisable to tilt the head before lifting machine.

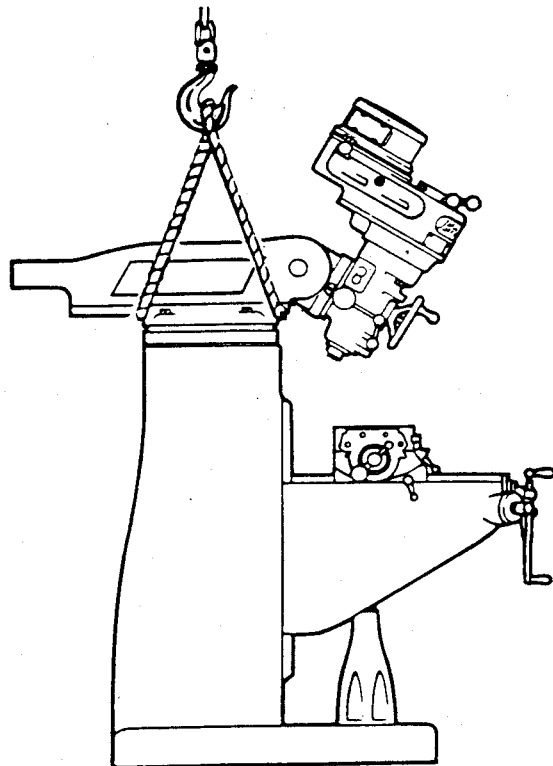

Installation

1. Remove rust preventative before moving any slideways.
2. The coating is best removed by using paraffin applied with a clean brush. When the coating has softened, remove with clean rags.
3. Oil or grease all lubrication points. Refer to the lubrication section of this manual (pages 3-1 onwards)
4. Check all equipment against the delivery note. Any discrepancies should be reported IMMEDIATELY and confirmed in writing to the company at the address on the back cover of this manual, or to our appropriate overseas distributor.

1.2 Cleaning

Installation

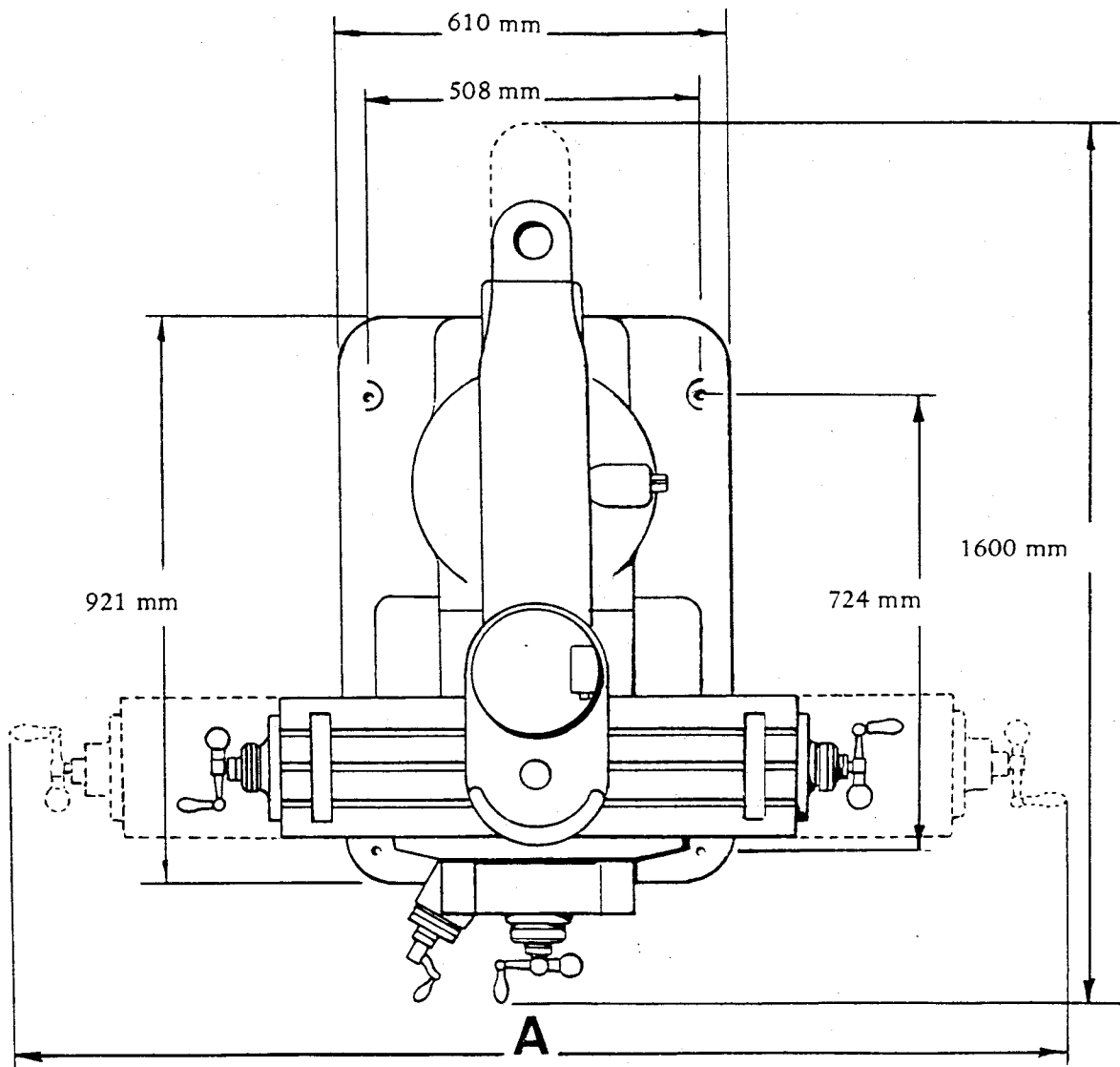

'A' DIMENSION

Table Size	Plain Machine	Power Feed
914 mm (36")	1778 mm (70")	1930 mm (76")
1067 mm (42")	1930 mm (76")	2083 mm (82")
1219 mm (48")	2083 mm (82")	2235 mm (88")

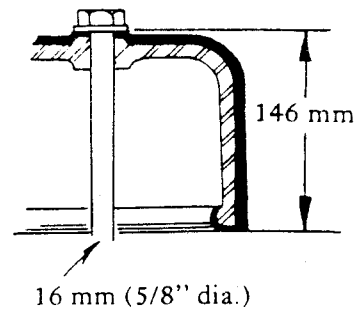

Installation

FOUNDATION

Ideally all milling machines should be bolted to a concrete foundation.

The Bridgeport however should be placed on a solid level floor or anti-vibration pads to prevent any rocking movement.

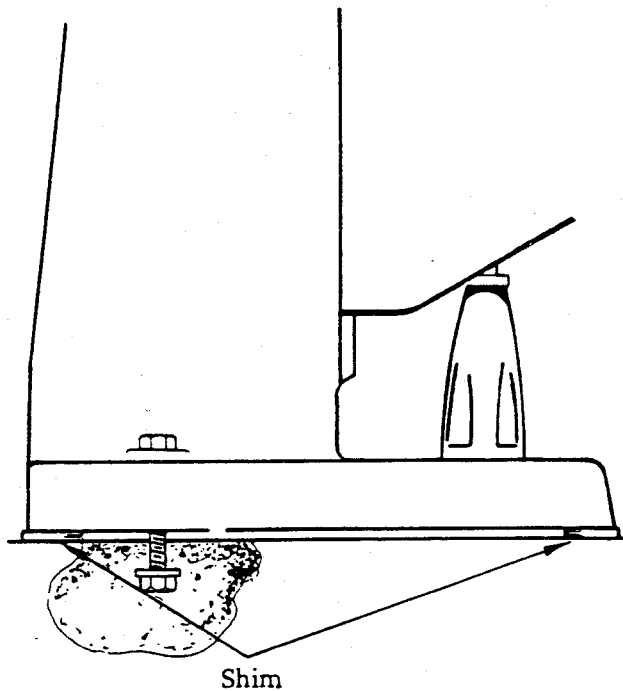

POWER SUPPLY

- Check the panel voltage against the main supply.
- Connect the supply to the isolator (diagram).
- Check for correct spindle rotation. (In the *HIGH SPEED* range the spindle should rotate clockwise when viewed from the top of the machine).

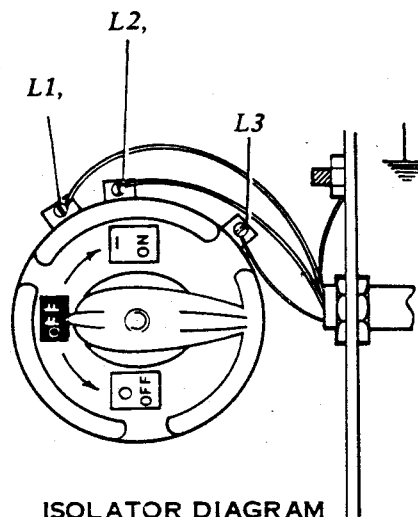

ISOLATOR DIAGRAM

MACHINES SUPPLIED WITHOUT CONTROL PANEL

- Check motor voltages against supply.
- Ensure that the supply is connected to comply with the local safety regulations. Note the 'J' Head switch has *NO* overload protection, when a Bridgeport control panel is not fitted.

Installation

1. If the machine was delivered in a crate, the slideway handles will have been reversed. These should be fitted as illustrated on pages 4-1/4-2
2. To prepare your Bridgeport if delivery is made with the milling head in an upside down position:-
 - a) Lower knee approximately 150 mm (6").
 - b) Withdraw the safety pin on the left hand side of ram adaptor (illustrated on page 2-3)
 - c) Slacken the four unit head mounting bolts.
 - d) Support unit head manually and use a spanner on swivel bolt (fig. b) to wind into upright position.
 - e) Press the safety pin back into the ram adaptor after passing the 25° mark.
 - f) Tighten the four unit head mounting bolts.

NOTE: For continuous operation in the horizontal plane the head lubrication system must be modified (drawing supplied on request).

To set a milling head square to the table, two methods are available:-

- (i) Using a large 90° set square mounted on the table, align faces with square.
- (ii) An indicator mounted in the spindle nose travelling in a 115 mm (4½") radius. It is important that each axis is set separately and locked.

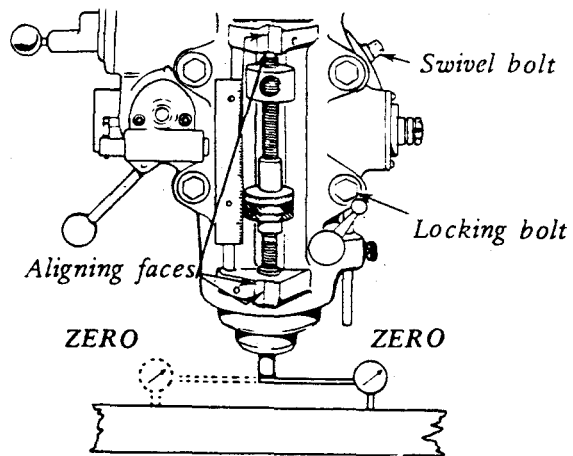
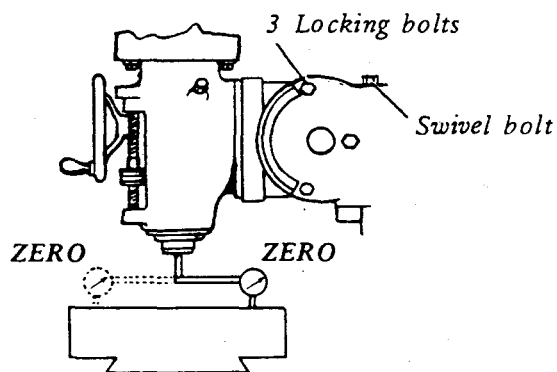

Fit ancillary equipment

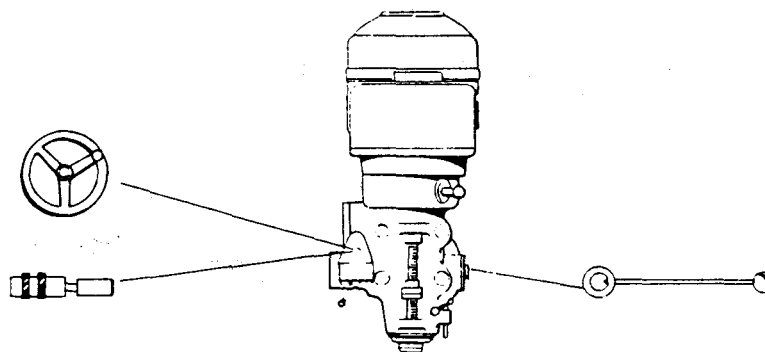

Operation

1. CLAMPING THE SADDLE KNEE SLIDE

Moderate pressure is sufficient. Excess pressure will cause distortion and make the table stiff to wind.

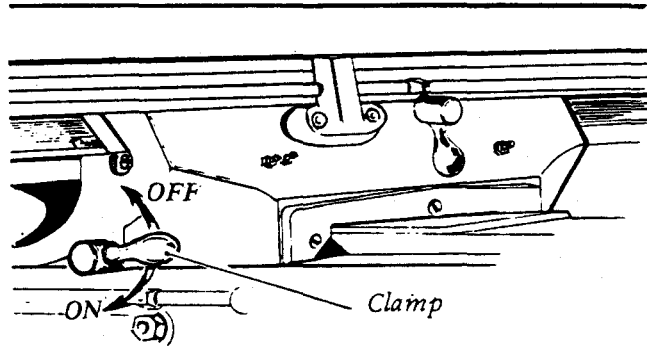

2. CLAMPING THE TABLE SADDLE SLIDE

Moderate pressure is sufficient.

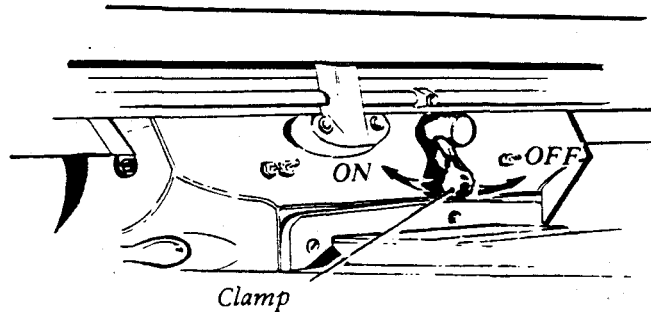

3. CLAMPING THE KNEE COLUMN SLIDE

Moderate pressure is sufficient.

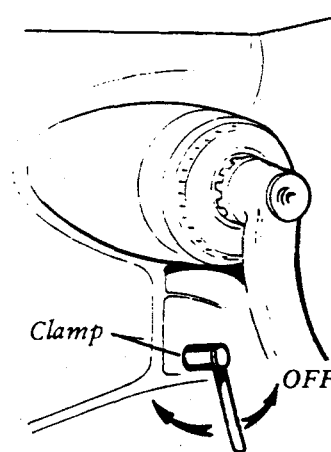

2.1 Machine Controls

Operation

4. SWIVEL TURRET

- a) Use Bridgeport spanner and unlock the 4 bolts.
- b) Index to the required setting.
- c) Lock the 4 bolts.

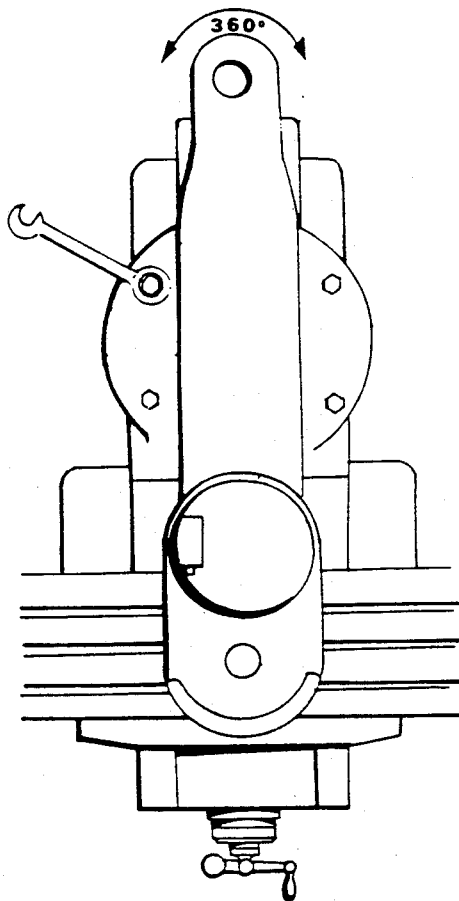

5. MOVE RAM SLIDE

- a) Use Bridgeport spanner and unlock the two bolts.
- b) Turn the handle to move the slide to the desired position.
- c) Lock, tightening the rear bolt first.

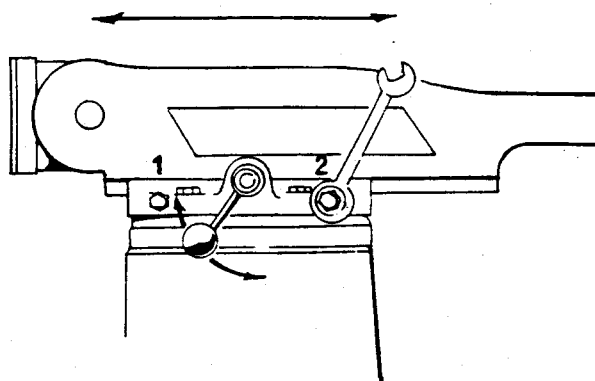

Operation

6. ELECTRIC CONTROLS

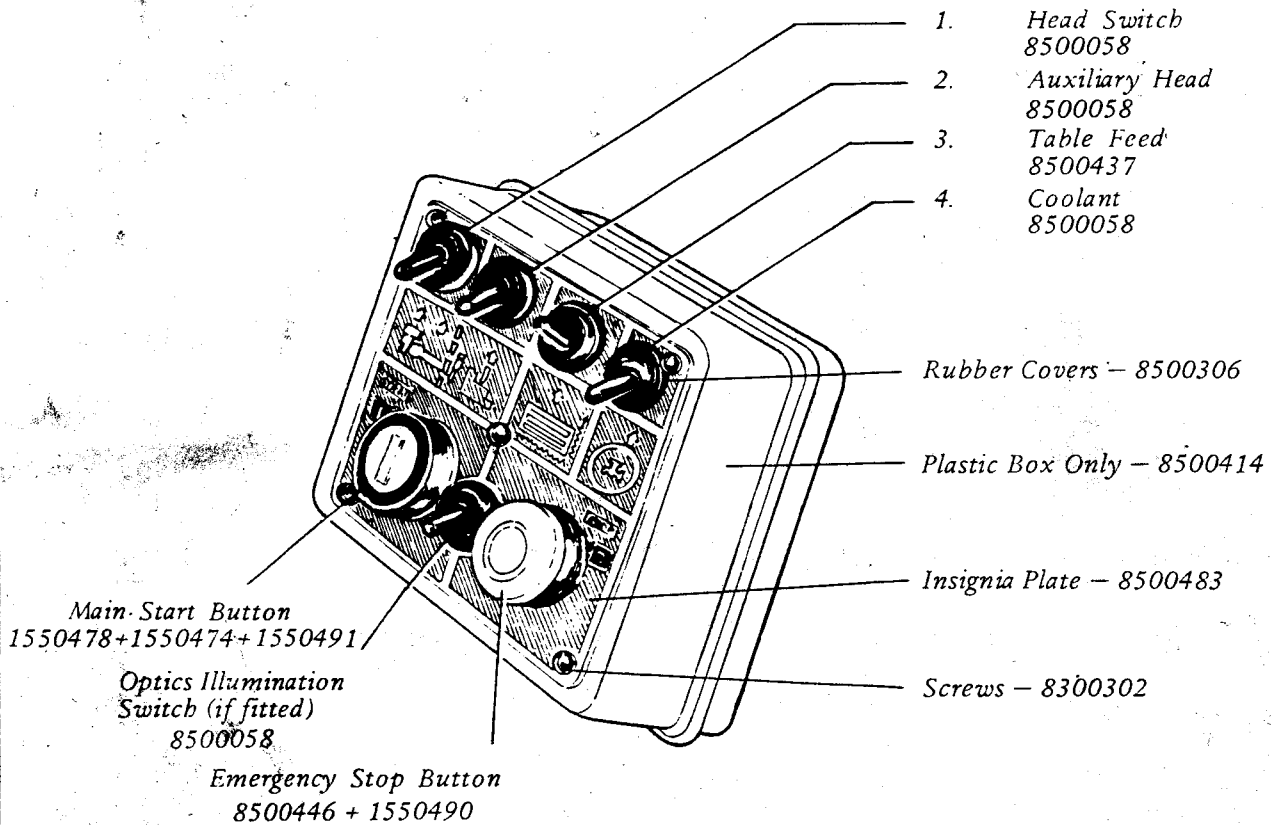

The circuitry is arranged to give full overload protection for all motors. As an extra safety feature, the milling head and table feed motors are interlocked so that in the event of the spindle stalling, the feed will automatically stop. Therefore, to operate the table feed, first switch on the head and then the feed switch.

2.1 Machine Controls

Operation

4. QUILL FEED

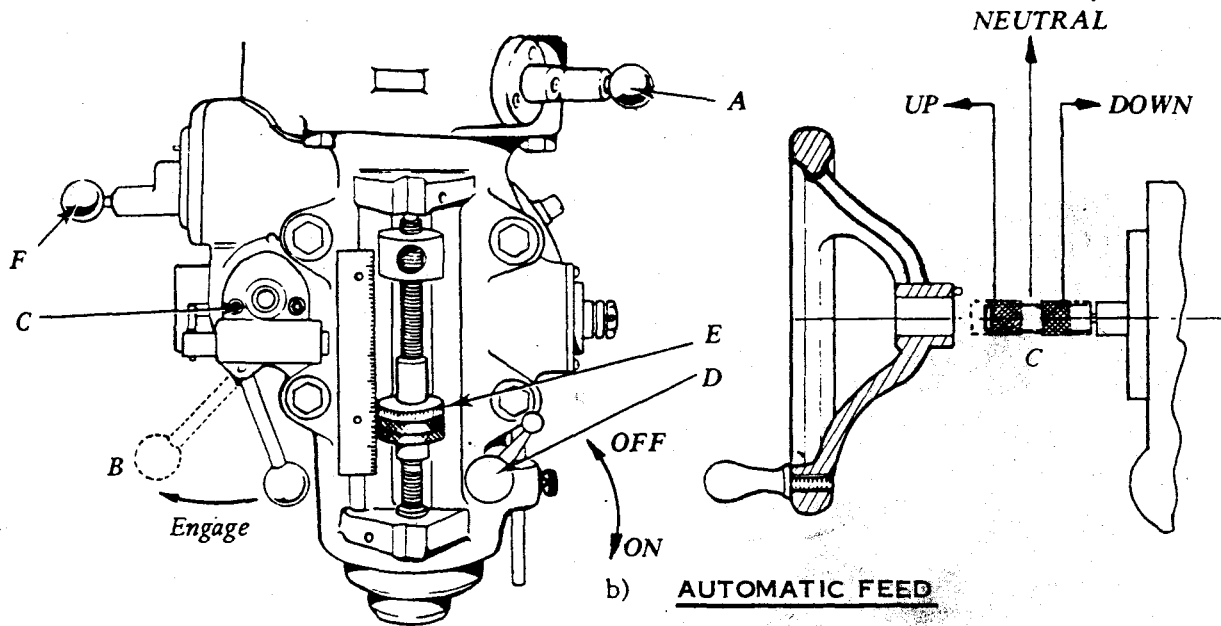

a) FINE HAND FEED

- i. Disengage Auto Quill Feed 'A'.
- ii. Locate 'C' in mid (neutral) position.
- iii. Engage Feed Trip Lever 'B'.
- iv. The Quill is now under handwheel control.

b) AUTOMATIC FEED

Maximum loading 3/8" (9.5mm) dia. drill in steel.

- i. Ensure quill lock is off 'D'.
- ii. Set micrometer dial to required depth 'E'.
- iii. Engage auto quill feed 'A' (when motor has stopped).
- vi. Select feed rate 'F'.
- v. Select feed direction 'C'.
- vi. Engage feed trip lever 'B'.
- vii. The feed will automatically trip out at a depth within $\pm 0.10''$ ($\pm .25\text{mm}$).
- viii. Hand feed to dead stop for repeating accuracy $\pm .001''$ ($\pm .025\text{mm}$).

DO NOT ENGAGE QUILL FEED 'A' OVER 3,000 R.P.M.

Operation

5. SPINDLE SPEEDS (Stop motor before changing speed).

The 2 speed motor is designed to give an output of 1 h.p. at 1400 r.p.m. & 2 h.p. at 2800 r.p.m.

50 Hz

LOW	67	115	180	275
RANGE	550	920	1500	2300
HIGH	134	230	360	550
RANGE	1100	1840	3000	4600

SWITCH POSITION 1

SWITCH POSITION 2

60 Hz

LOW	80	135	210	325
RANGE	660	1115	1725	2720
HIGH	160	270	420	650
RANGE	320	2230	3550	5440

SWITCH POSITION 1

SWITCH POSITION 2

Operation

6. SPINDLE SPEED RANGES

a) *Change Speed Within Range*

- i. Isolate machine.
- ii. Remove belt guards.
- iii. Slacken 2 motor lock levers 'A'.
- iv. Slide motor forward.
- v. Position belt on appropriate pulleys.
- vi. Slide motor to the rear of tension vee belt.
- vii. Tighten 2 motor locking levers.
- viii. Refit belt guards.

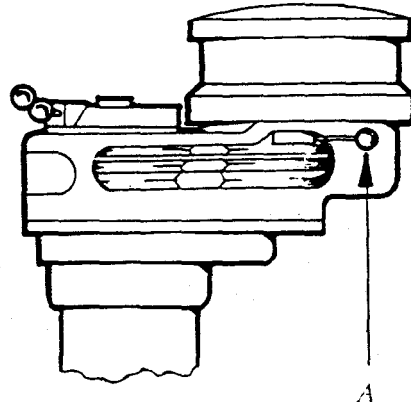

IMPORTANT to conform to Health & Safety at Work Act.

b) *Change Range*

1. From direct to back gear drive:-
 - i. Move lever B to the right.
 - ii. Move knob 'C' to "IN" position

NOTE: this action will **REVERSE** the spindle rotation. Move motor switch to reverse position to obtain original direction of spindle rotation.

2. From back gear to direct drive:-
 - i. Move lever 'B' to the front position
 - ii. Rotate spindle by hand until the clutches are felt to engage
 - iii. Move knob 'C' to "OUT" position

NOTE: this action will **REVERSE** the spindle rotation. Move motor switch to reverse position to obtain original direction of spindle rotation.

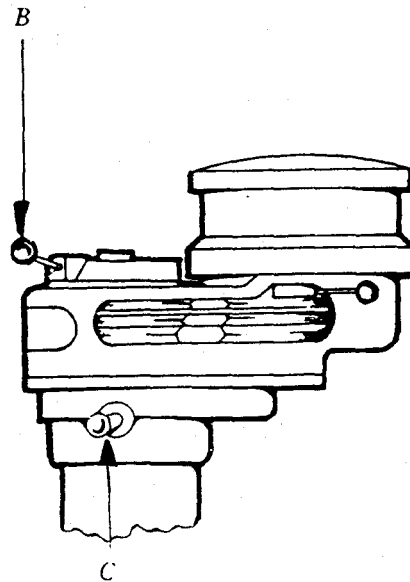

Operation

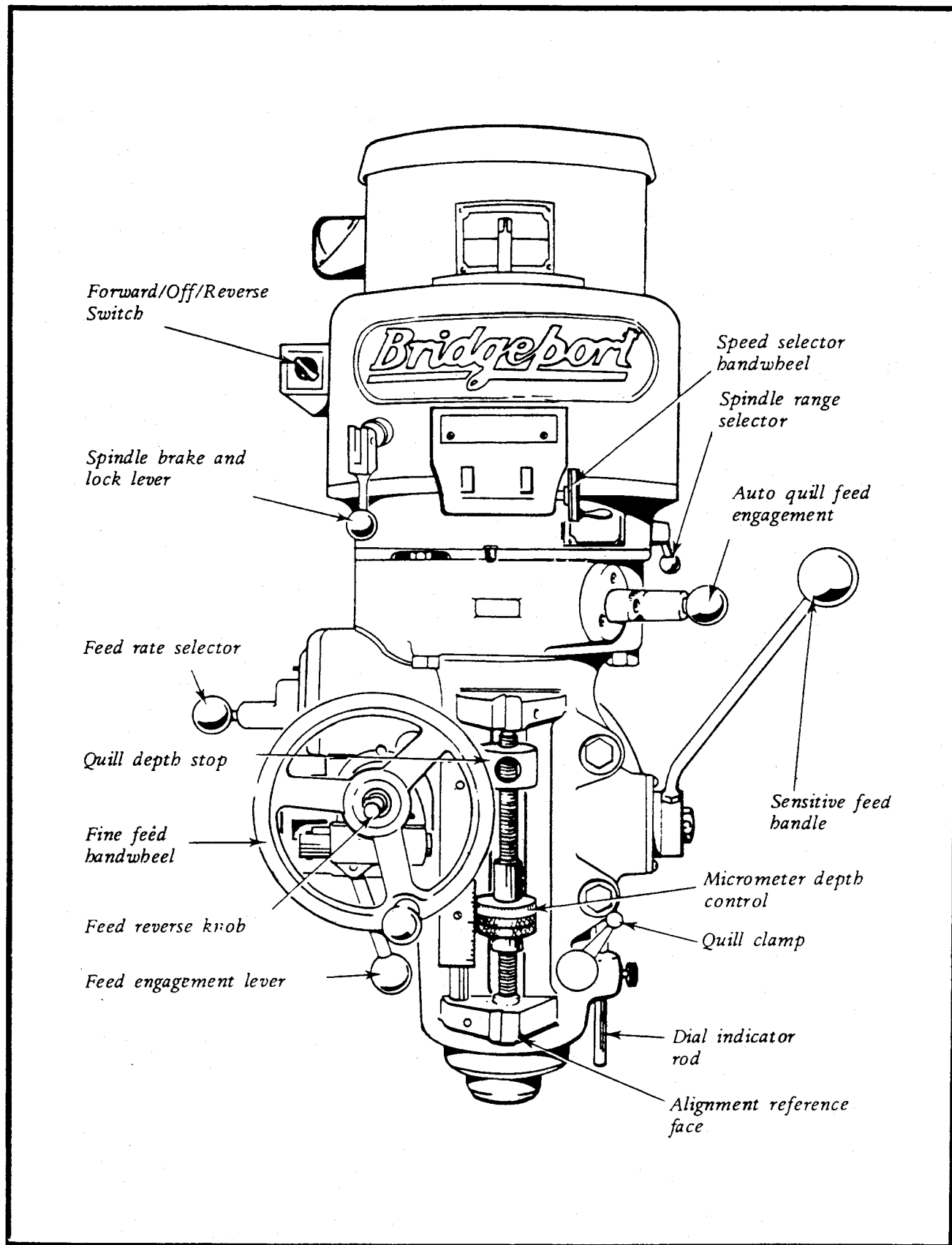

2.3 2J2 - Head Controls

Operation

1. SWIVEL BELT HOUSING

- i. Slacken 3 Locking Nuts 'A' (retain sufficiently to stop binding).
- ii. Swivel to required angular setting.
- iii. Tighten 3 Locking Nuts; before finally securing run spindle, to give correct spline alignment.

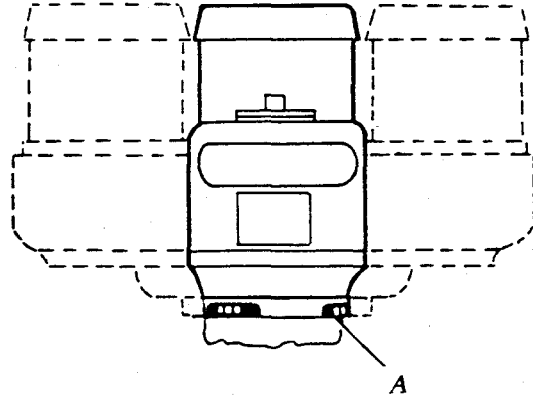

NOTE: Incorrect spline alignment can be caused by unequal tightening of the locking nuts 'A' causing varying stiffness of the quill feed which can be felt through the sensitive feed handle.

2. SPINDLE BRAKE see page 2-2

3. QUILL SENSITIVE HAND FEED see page 2-2

4. SWIVELLING HEAD

To swivel the head more than 25° , the safety pin 'B' must be pulled outwards.
(see reverse procedure on page 1-5)

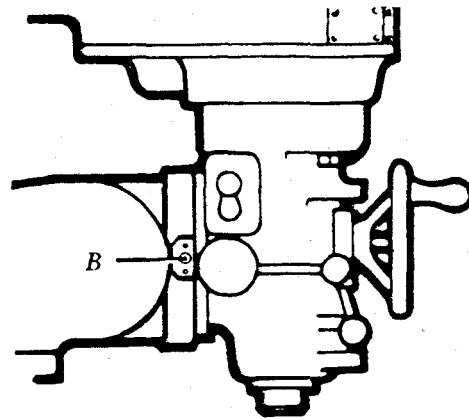

Operation

4. QUILL FEED

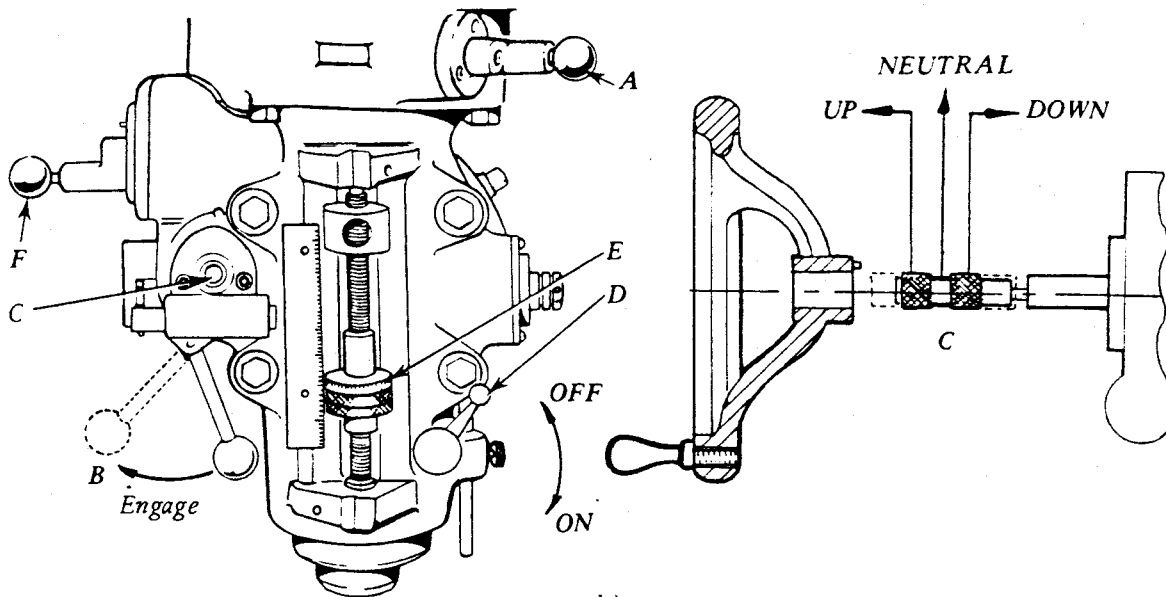

a) FINE HAND FEED

- i. Disengage Auto Quill Feed 'A'.
- ii. Locate 'C' in mid (neutral) position.
- iii. Engage Feed Trip Lever 'B'.
- iv. The Quill is now under handwheel control.

b) AUTOMATIC FEED

Maximum loading 3/8" (9.5mm) dia. drill in steel.

- i. Ensure quill lock is off 'D'.
- ii. Set micrometer dial to required depth 'E'.
- iii. Engage auto quill feed 'A' (when motor has stopped).
- iv. Select feed rate 'F'.
- v. Select feed direction 'C'.
- vi. Engage feed trip lever 'B'.
- vii. The feed will automatically trip out at a depth within $\pm .010''$ ($\pm .25\text{mm}$).
- viii. Hand feed to dead stop for repeating accuracy $\pm .001''$ ($\pm .025\text{mm}$).

DO NOT ENGAGE QUILL FEED 'A' OVER 3,000 R.P.M.

2.3 2J2 - Head Controls

Operation

5. SPINDLE SPEED (Change only when spindle is running)

a) *Change Speed Within Range*

- i. Start spindle.
- ii. Turn handwheel 'A' to select required speed.

Change only when spindle is running.

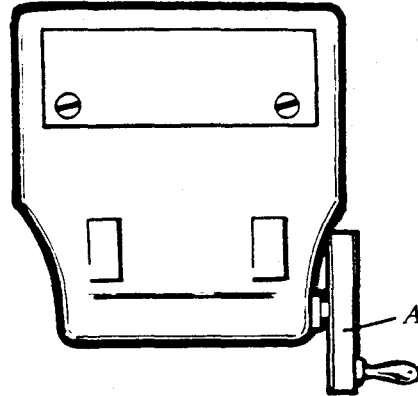

DO NOT CHANGE SPEED WHEN SPINDLE IS STATIONARY

b) *Change Range*

1. From direct to back gear drive:-
 - i. Switch 'B' to *OFF*.
 - ii. Move lever 'C' through neutral to *LOW* (this reverses the spindle rotation).
 - iii. Switch 'B' to *LOW*.

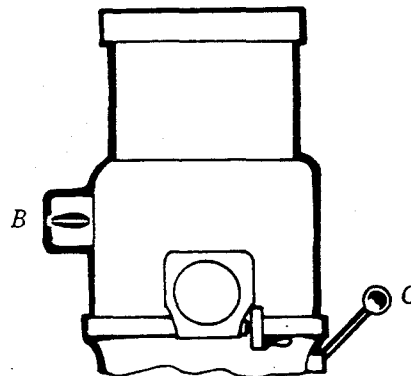

DO NOT CHANGE RANGE WHILST THE SPINDLE IS RUNNING

2. From back gear to direct drive:-
 - i. Switch 'B' to *OFF*.
 - ii. Move lever 'C' through neutral to *HIGH*.
 - iii. Rotate spindle by hand until the clutches are felt to engage.
 - iv. Switch 'B' to *HIGH*.

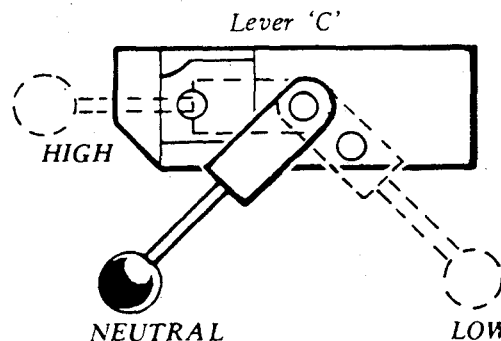

Operation

1. MECHANICAL TABLE FEED

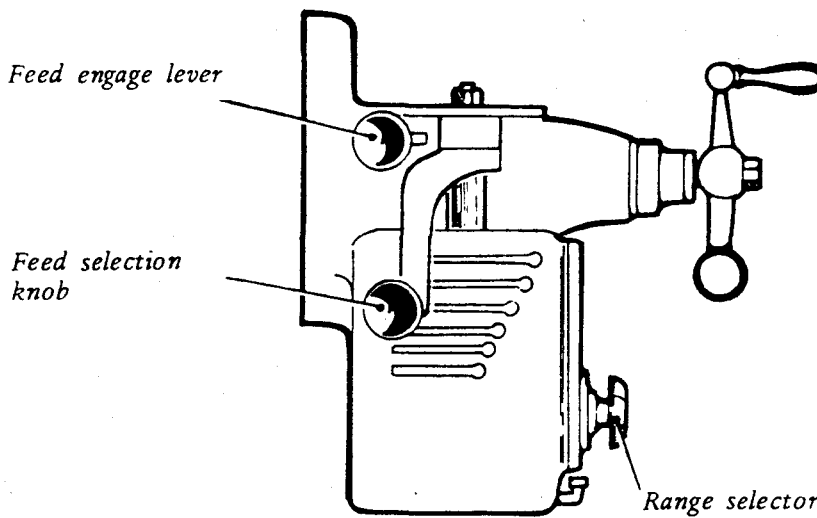
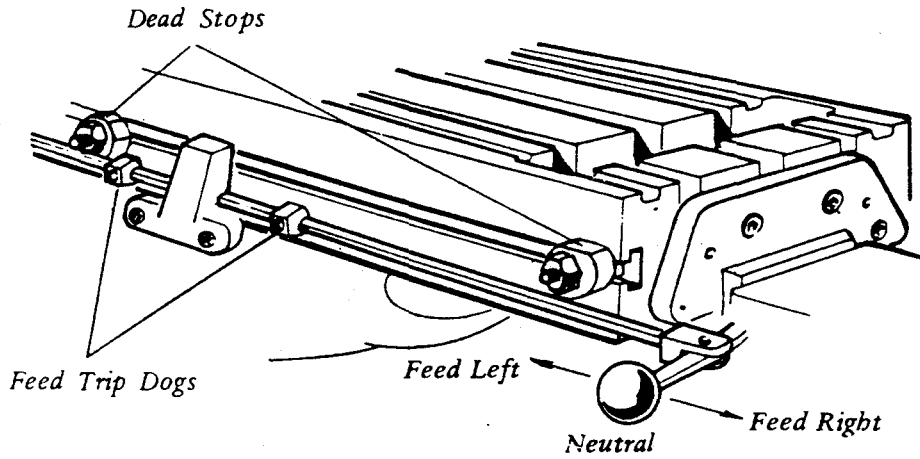

FEEDS
METRIC mm/per minute.

FEEDS
IMPERIAL inch/per minute.

12	16	19	25	33	41
54	71	90	118	155	190

Low range

High range

$\frac{7}{16}$	$\frac{5}{8}$	$\frac{3}{4}$	1	$1\frac{3}{8}$	$1\frac{5}{8}$
$2\frac{1}{8}$	$2\frac{7}{8}$	$3\frac{9}{16}$	$4\frac{3}{4}$	$6\frac{1}{4}$	$7\frac{9}{16}$

4 Mechanical Table Feed

Operation

2. 6F VARIABLE TABLE FEED

(applicable for machines with serial number suffixes from N onwards).

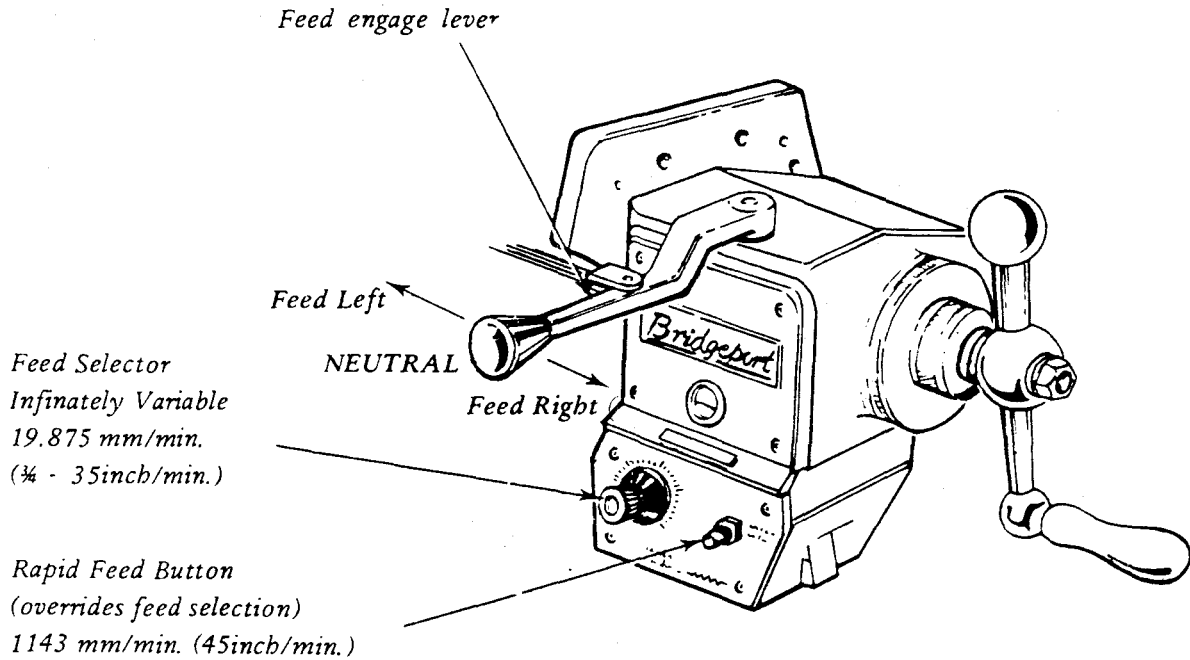

NOTE: Health & Safety at Work Act.
This is a safety device and should not be tampered with.

BALL HANDLE

Grip handle and turn to either left or right until spring loaded plunger engages in position on bush.

3. 6F VARIABLE CROSSLIDE FEED

(available only for machines fitted with 6F table feed).

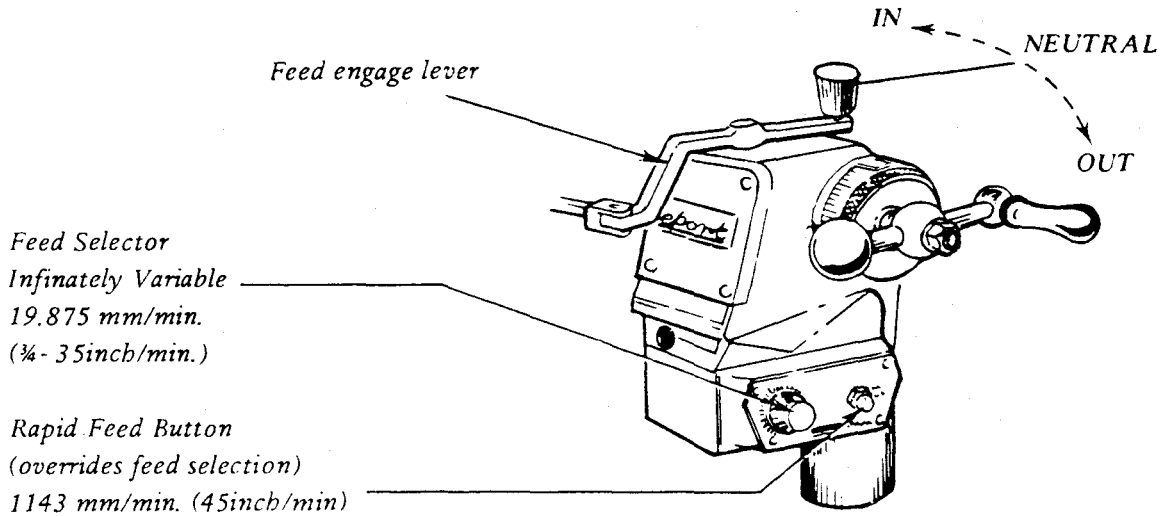

Operation

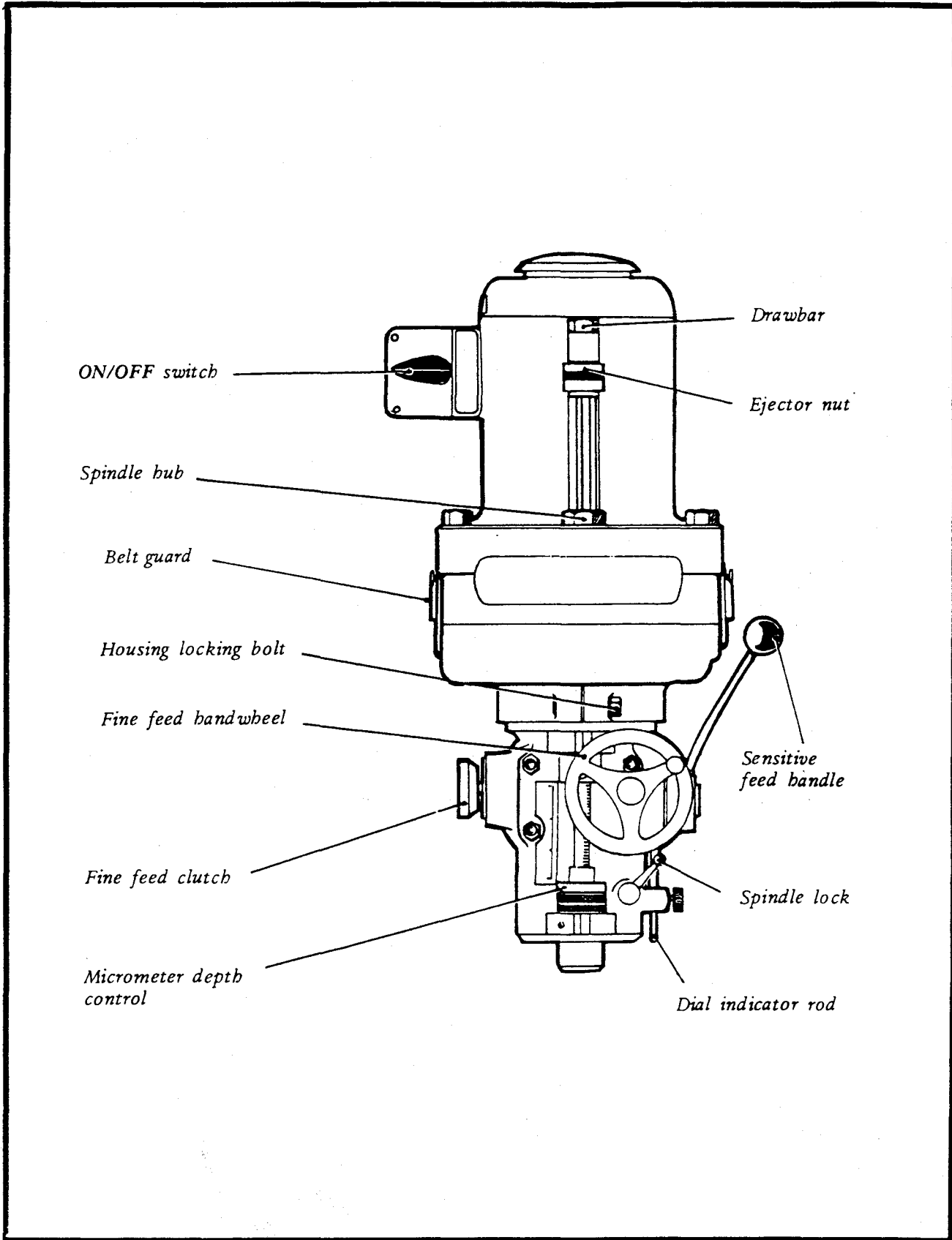

2.6 M-Head Controls

M/C SERIAL N^o JB 10743

Operation

JHD - 8500062 5 Position Switch Box = 8500060

2JHD - 8500061 3 Position Switch Box = 8500330

Forward/Off/Reverse Switch

(The two speed motor fitted as standard is provided with a 5 position 2 speed forward reverse and off controller)

Spindle clutch lever to be used in conjunction with back gear selector.

Spindle brake and lock

Motor lock levers

Belt guard

Alignment reference face

Feed rate selector

Feed reverse knob 7000117

Fine feed handwheel 7000120

Feed engagement lever

Back gear selector

Automatic quill feed engagement

Sensitive feed handle 8009053/4

Quill depth stop

Micrometer depth stop

Quill clamp

Dial indicator rod

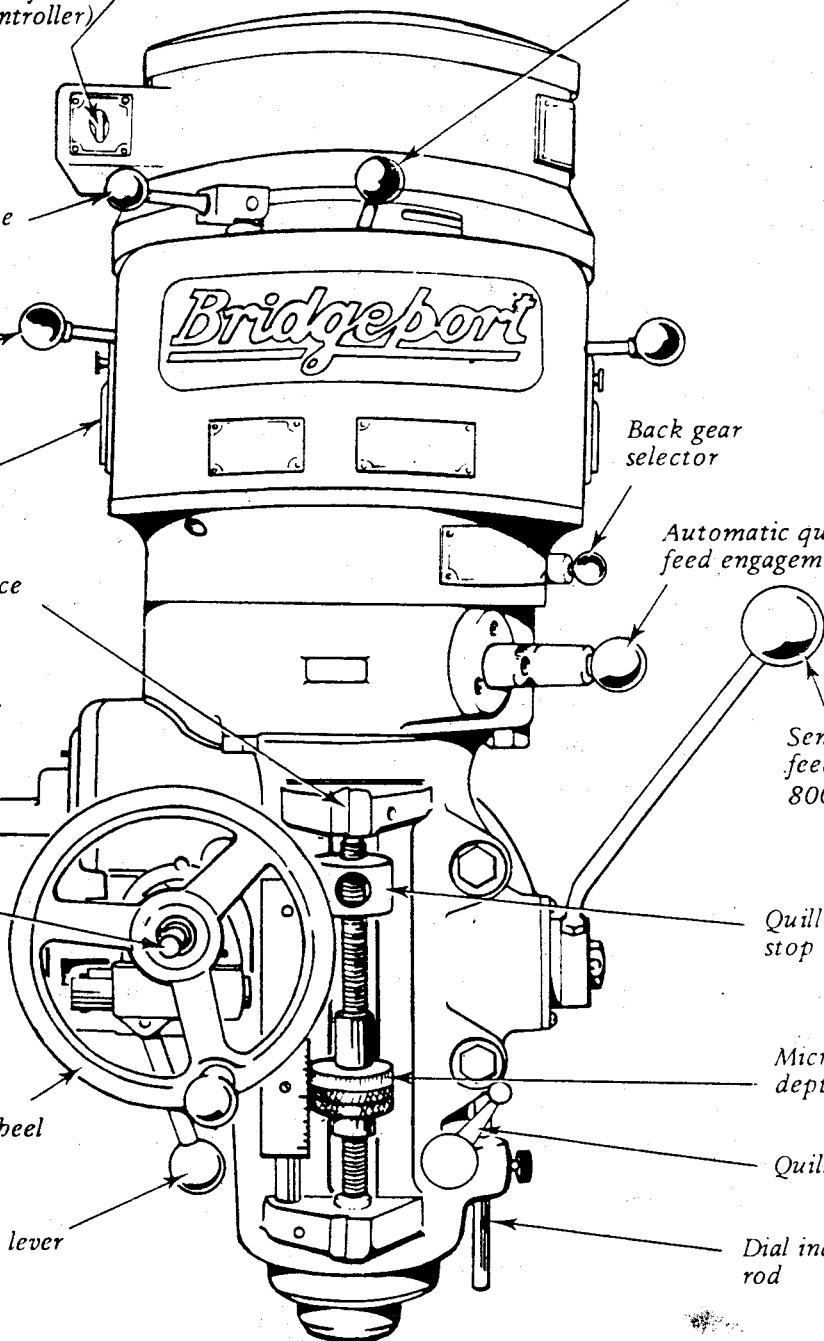

Operation

1. SWIVEL BELT HOUSING

- i Slacken three Locking Nuts 'A'. (Retain sufficiently to stop binding).
- ii Swivel to required angular setting.
- iii Tighten three Locking Nuts; before finally securing, run spindle to give correct spline alignment.

NOTE: Incorrect spline alignment can be caused by unequal tightening of the locking nuts 'A' causing varying stiffness of the quill feed which can be felt through the sensitive feed handle.

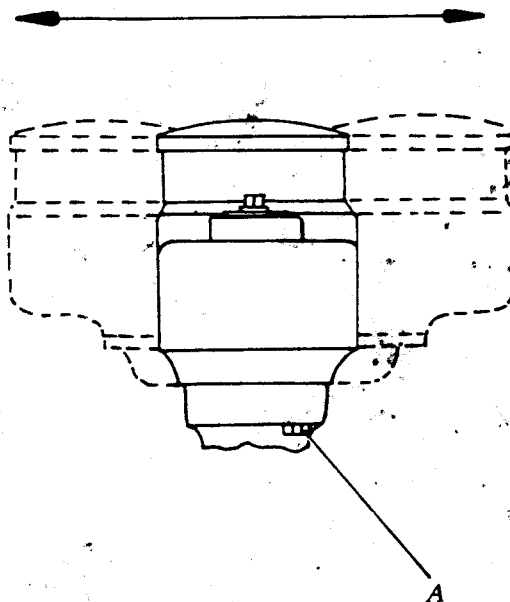

2. SPINDLE BRAKE

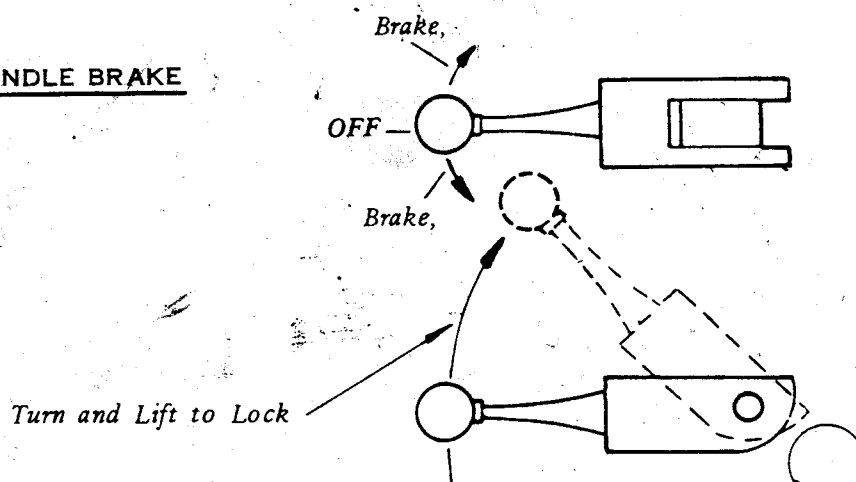

3. QUILL SENSITIVE HAND FEED

- i Place the handle on the boss.
- ii Select the most suitable position.
- iii Push home until the locating pin engages.

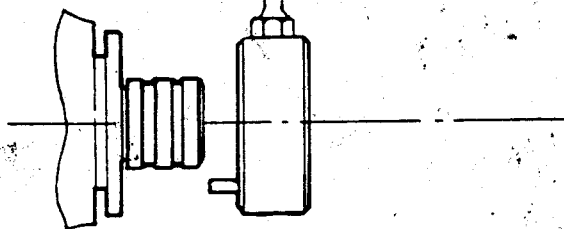

Operation

1. SWIVEL HEAD

- i. Slacken the 4 locking nuts (hold unit to prevent free fall).
- ii. Swivel to required angular setting.
- iii. Tighten 4 locking nuts.

NOTE: For continuous operation in the horizontal plane, the head lubrication system must be modified (drawing supplied on request).

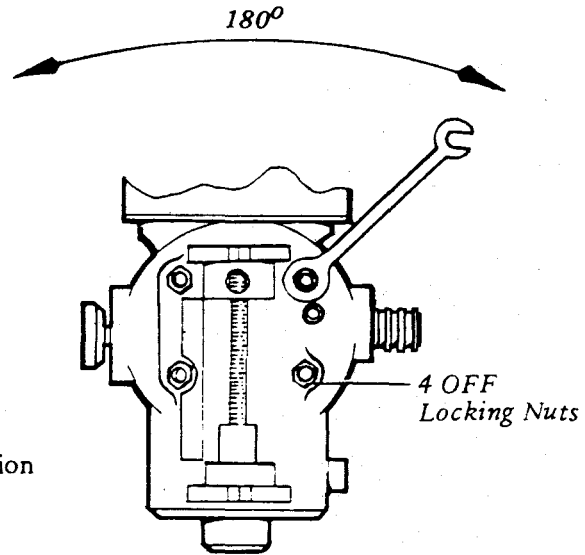

2. SWIVEL BELT HOUSING

- i. Slacken locking nut 'A'.
- ii. Swivel to required setting.
- iii. Tighten locking nut; before finally securing, run spindle to give correct spline alignment.

NOTE: Incorrect spline alignment can be caused by unequal tightening of the locking nut, causing varying stiffness of the quill feed which can be felt through the sensitive feed handle.

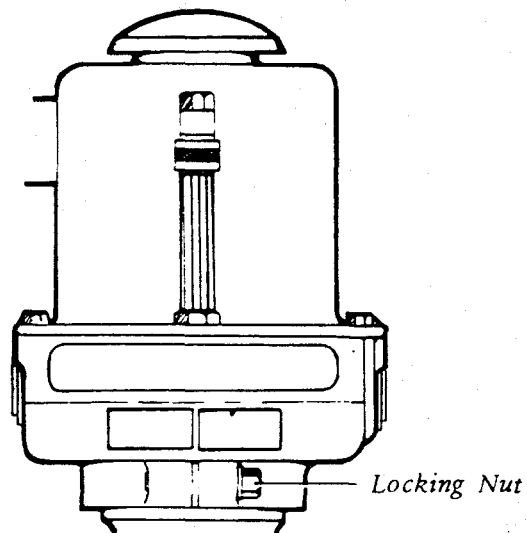

3. DRAWBAR

- i. Use a spanner on nut 'A' as a spindle brake.
- ii. Eject or tighten collet by turning nut 'B'.
- iii. Keep nut 'C' tight against the spindle at all times.

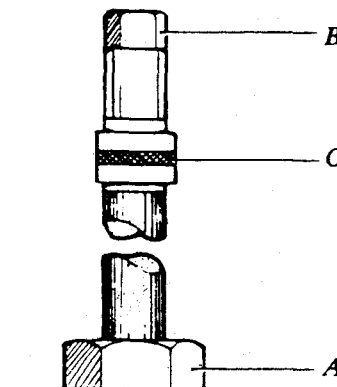

Operation

4. SPINDLE SPEEDS

The $\frac{3}{4}$ h.p. motor provides a range of spindle speeds from 330–5100 r.p.m.

5. CHANGE SPEED

- i. Slacken the 2 locking nuts 'A'.
- ii. Slide motor forward.
- iii. Remove belt guards.
- iv. Position belt on appropriate pulleys.
- v. Slide motor to the rear of tension vee belt.
- vi. Tighten the two locking nuts 'A'.
- vii. Refit belt guards.

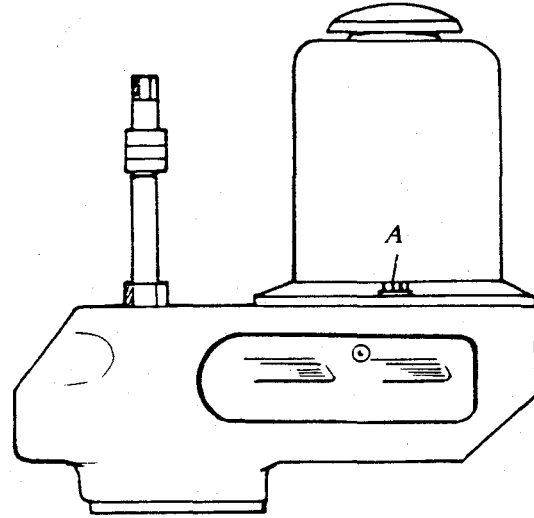

IMPORTANT to conform to Health & Safety at Work Act.

6. QUILL FEED

a) *Sensitive Hand Feed*

- i. Place handle on to boss.
- ii. Select most suitable position.
- iii. Push home until locating pin engages.

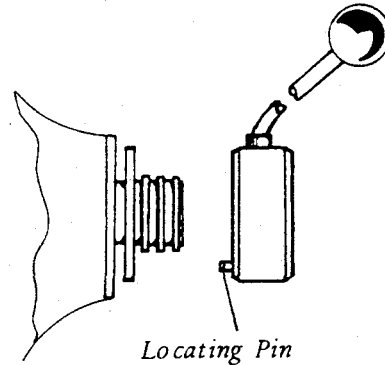

b) *Fine Hand Feed*

- i. Turn the fine feed clutch 'A' clockwise to engage the clutch.
- ii. The quill is now under handwheel control.

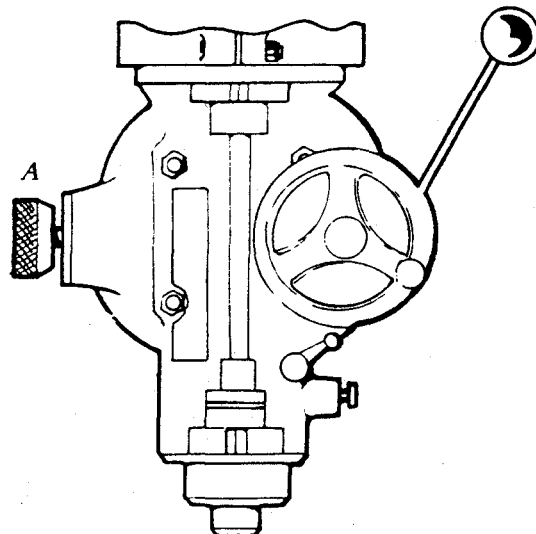

Operation

1. CONTROLS

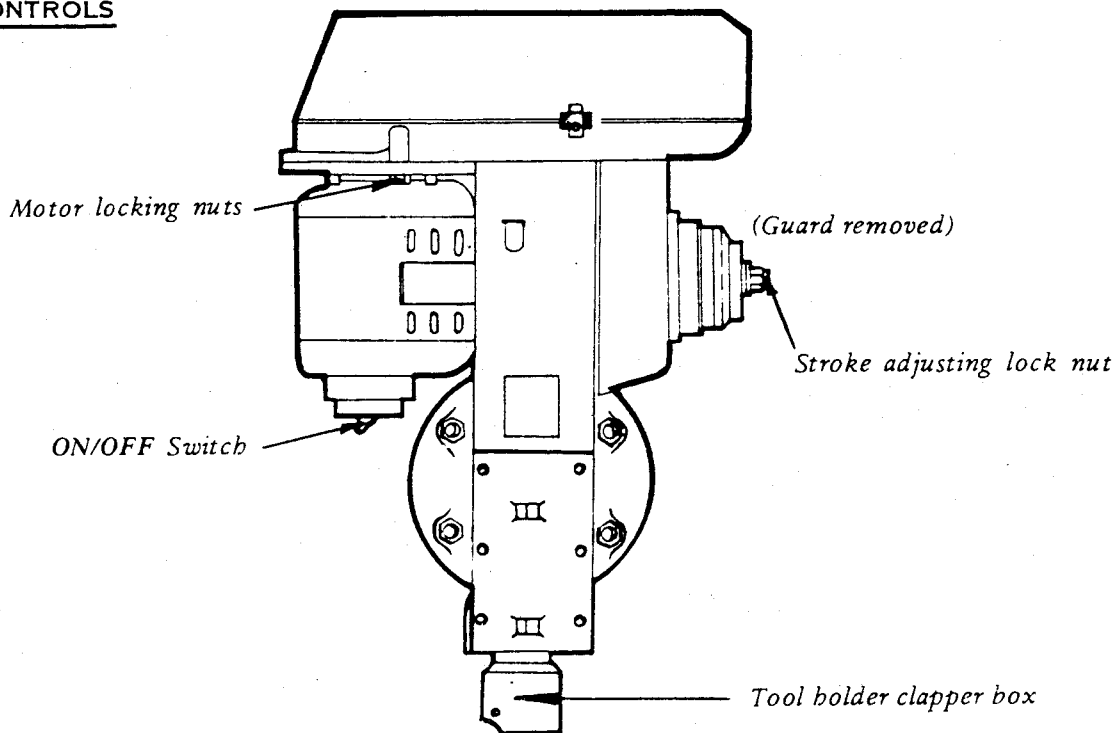

2. HEAD SWIVEL

- i. Slacken the 4 Locking Nuts (hold unit to prevent free fall).
- ii. Swivel to required angular setting.
- iii. Tighten the 4 Locking Nuts.

NOTE:

Remove screw sealing vent hole, before operating machine see page 4-13.

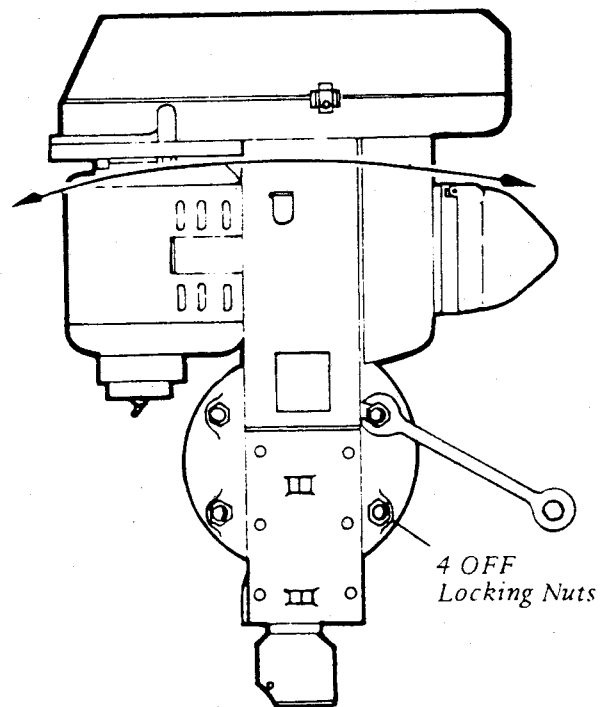

Operation

3. TO CHANGE SPEED

- i. Isolate machine.
- ii. Slacken the 2 motor locking nuts.
- iii. Slide motor forward.
- iv. Position vee belt on appropriate pulleys.
- v. Slide motor to rear to tension vee belt.
- vi. Tighten the 2 motor locking nuts.

With 50 cycle 1425 r.p.m.
60, 85, 120, 170, 245, 350, strokes per minute.

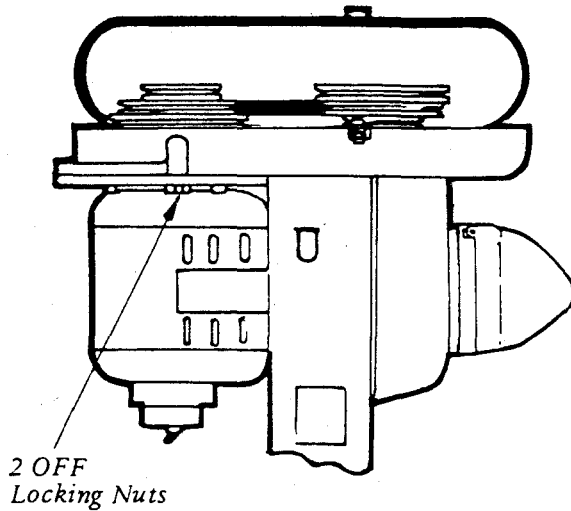

4. TO CHANGE STROKE

- i. Slacken lock nut.
- ii. Turn stroke dial to required setting.
- iii. Press dial home to engage pin.
- iv. Tighten lock nut.
- vi. Before operating attachment ensure locknut is tight.

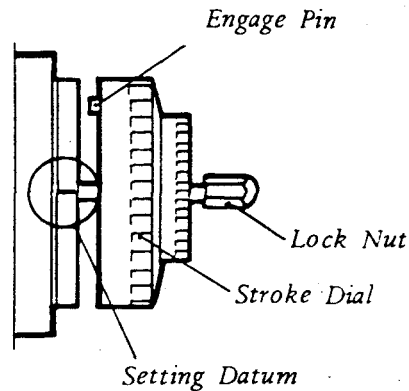

5. CLAPPER BOX

- a) To Swivel Clapper Box
 - i. Slacken the 2 set screws 'A'.
 - ii. Rotate to the required angular setting.
 - iii. Tighten the 2 set screws 'A'.
- b) Tool Relief
 - i. Slacken set screw 'B'.
 - ii. The tool will now have automatic relief on the return stroke.

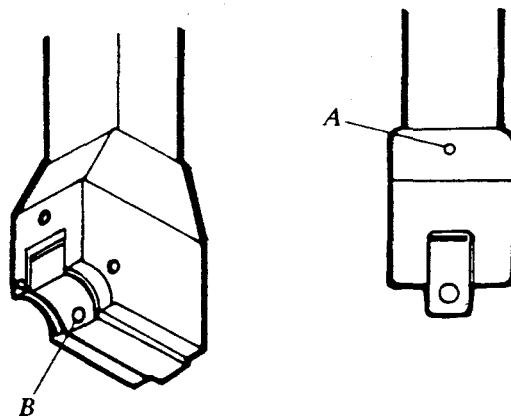

Operation

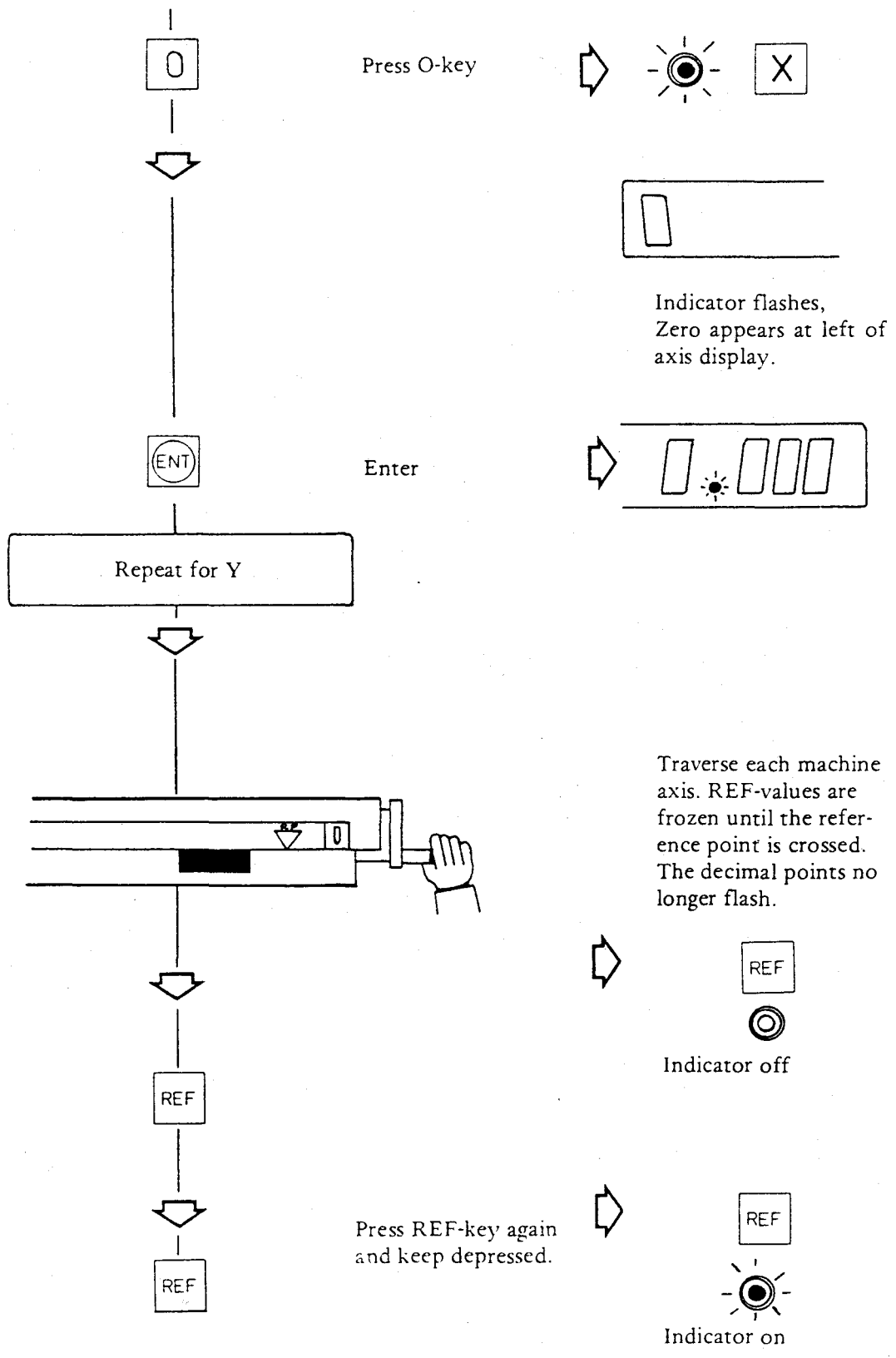

Operation

Traverse slides back over reference points.



Axis displays read zero with decimal point flashing.

Operation

EQUIPMENT

(a) Consists of a 26" scale and scanning unit known as the "X" axis transducer (attached to rear of table).

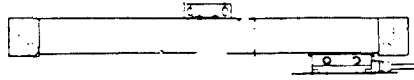

(b) 12" scale and scanning unit known as the "Y" axis transducer.

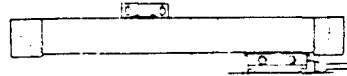

(c) A Display Unit having:—

- two axes displays
- inch/mm conversion facility
- incremental/absolute dimensions
- permanently stored reference and datum points

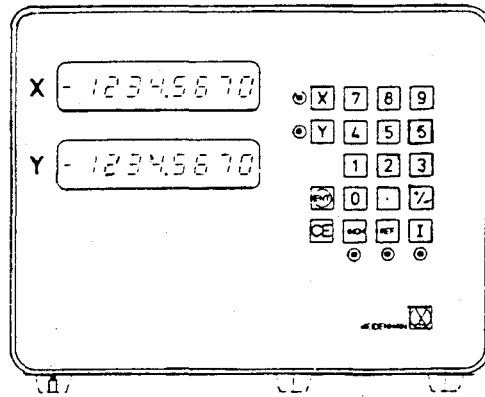

FRONT VIEW OF DISPLAY UNIT

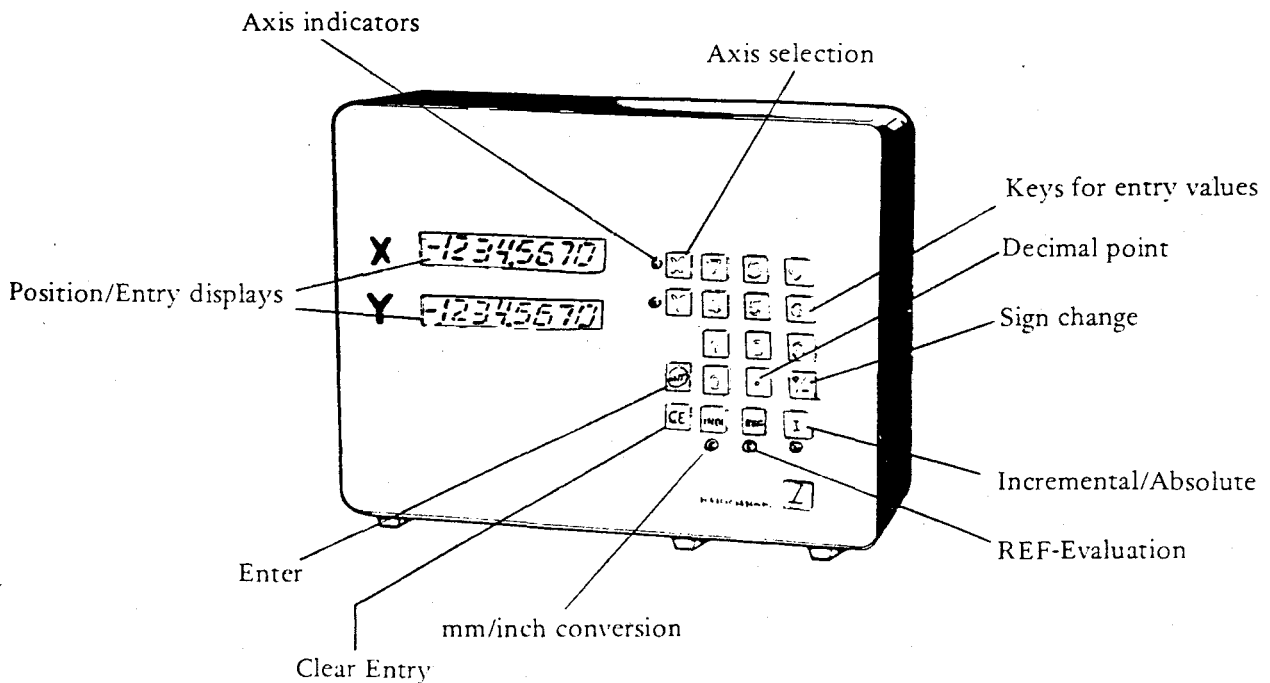

Operation

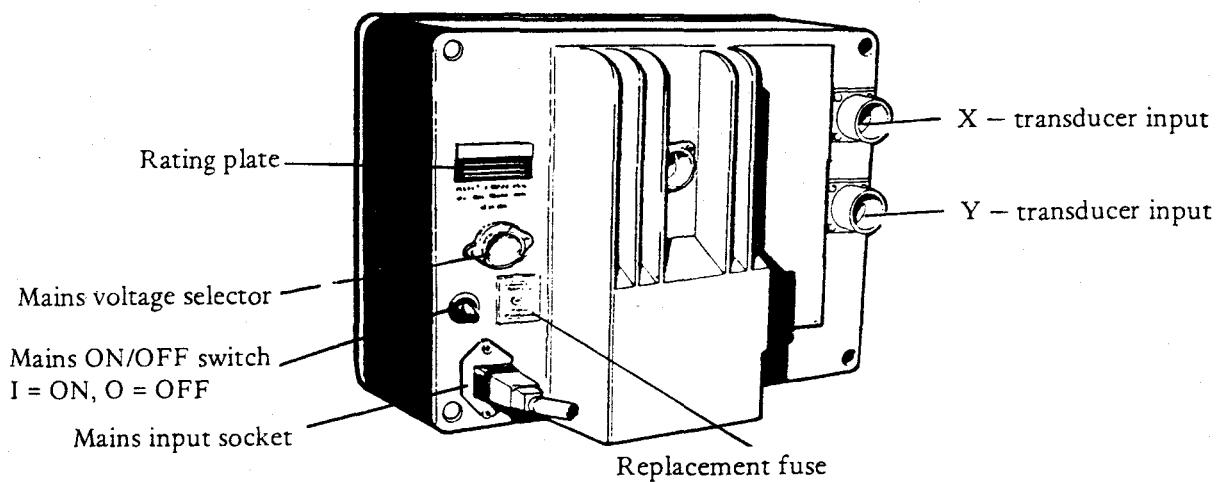

To verify proper DRO-functioning and that all connections are correct, the following simple check should be performed:

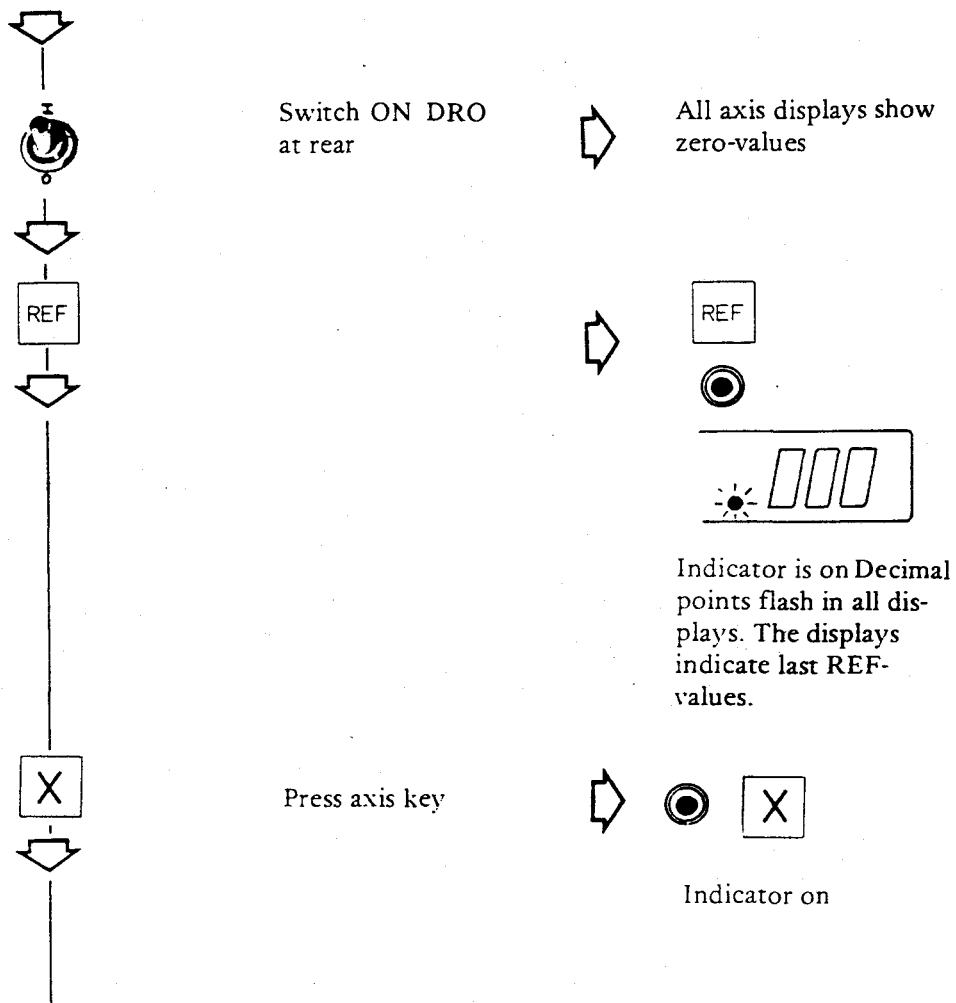

Lubrication

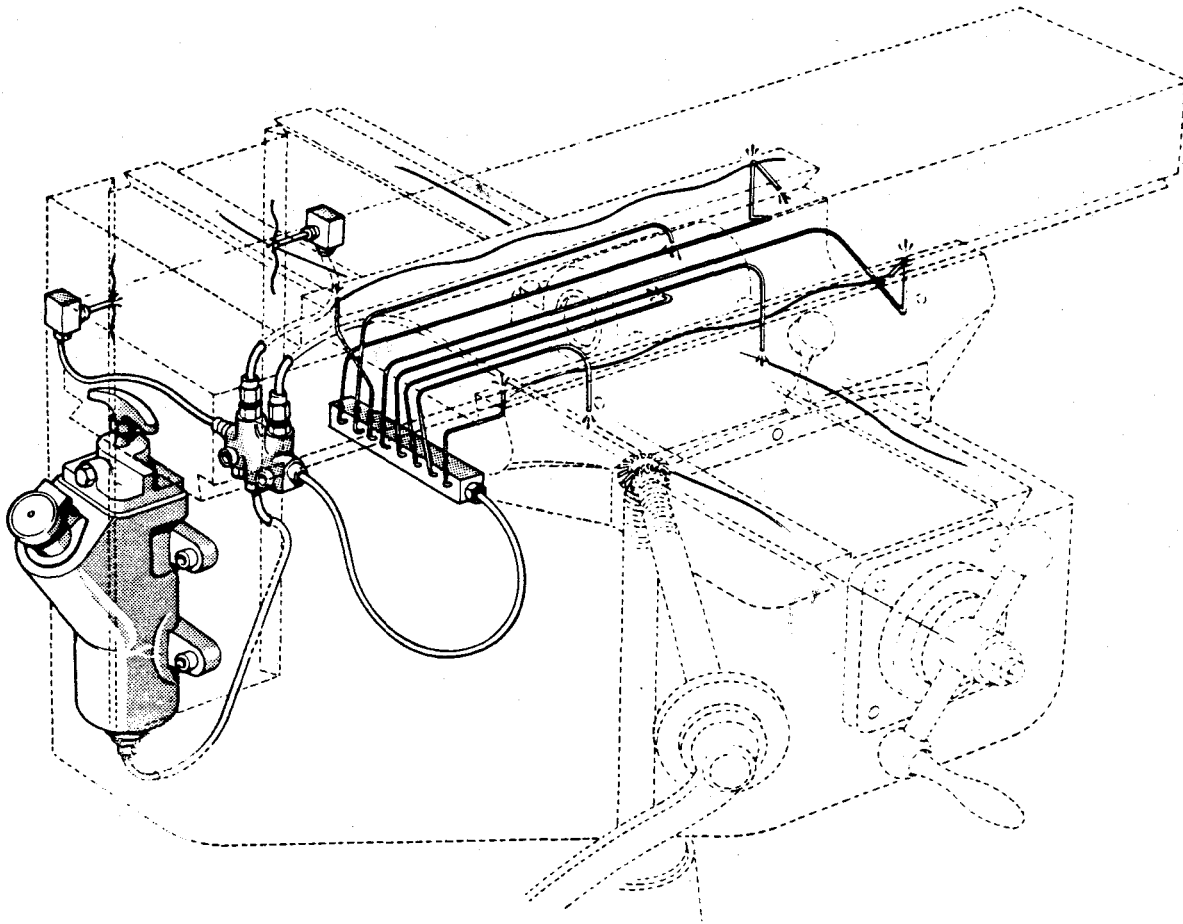

CENTRALISED LUBRICATION SYSTEM

Actuate daily

Check level weekly and fill with Vactra No. 2 lubricant if necessary.

Lubrication

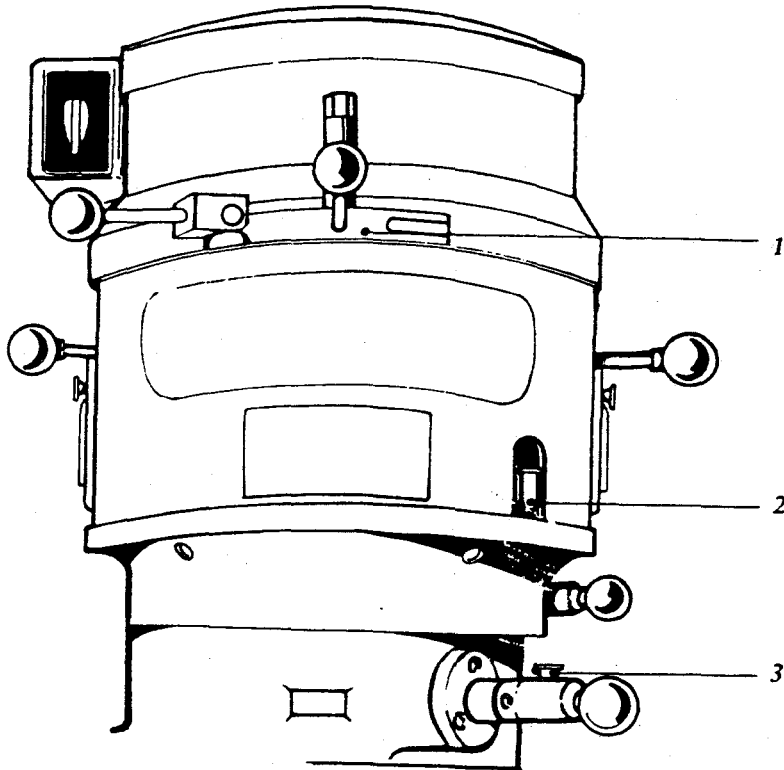

FREQUENCY	LUBRICATE	LUBRICANT	QUANTITY	LUB. AT
Twice Weekly	Pulley Cam	Vactra Heavy Medium	5 drops	1
Twice Daily	Spindle Bearing/ quill feed	Vactra Heavy Medium	Top-up	2
Twice Daily	Quill Bearings	Vactra Heavy Medium	Top-up	3

NOTE:

Failure to lubricate "Quill bearings" at 3 can result in tight quills and partial seizure of quill in housing.

3.2 J-Head

Lubrication

2J VARIDRIVE HEAD

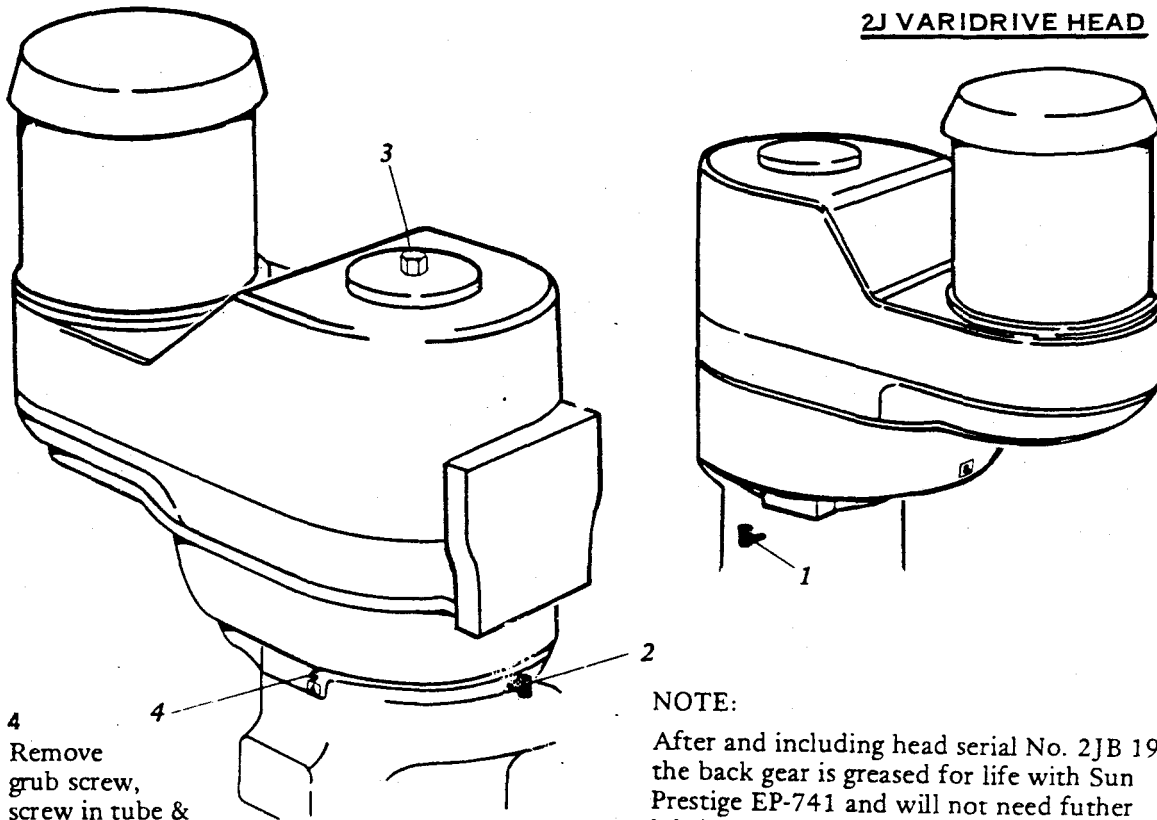

4 Remove grub screw, screw in tube & squeeze in required amount.

NOTE:
After and including head serial No. 2JB 1970 the back gear is greased for life with Sun Prestige EP-741 and will not need further lubrication.

FREQUENCY	LUBRICATE	LUBRICANT	QUANTITY	LUB. AT
Twice Daily	Quill Bearings	Light Spindle Oil	5-10 drops	1
Twice Daily (when feed is in use)	Spindle Down Feed	Vactra Heavy/Medium	Top-up	2
Weekly	Drawbar Splines	Vactra Heavy/Medium	5 drops	3 (move quill down 2")

Failure to lubricate "Quill Bearings" at 1 can result in tight quills and partial seizure of quill in housing.

FREQUENCY	LUBRICATE	LUBRICANT	QUANTITY	LUB. AT
Every 6 months	Bull gear shifting mechanism	Lubriplate No.107	Equivalent of 1/2 teaspoonful	4 NOTE: When greasing work Hi-Lo lever

Lubrication

6F LONGITUDINAL AND CROSS VARIFEEED BOXES

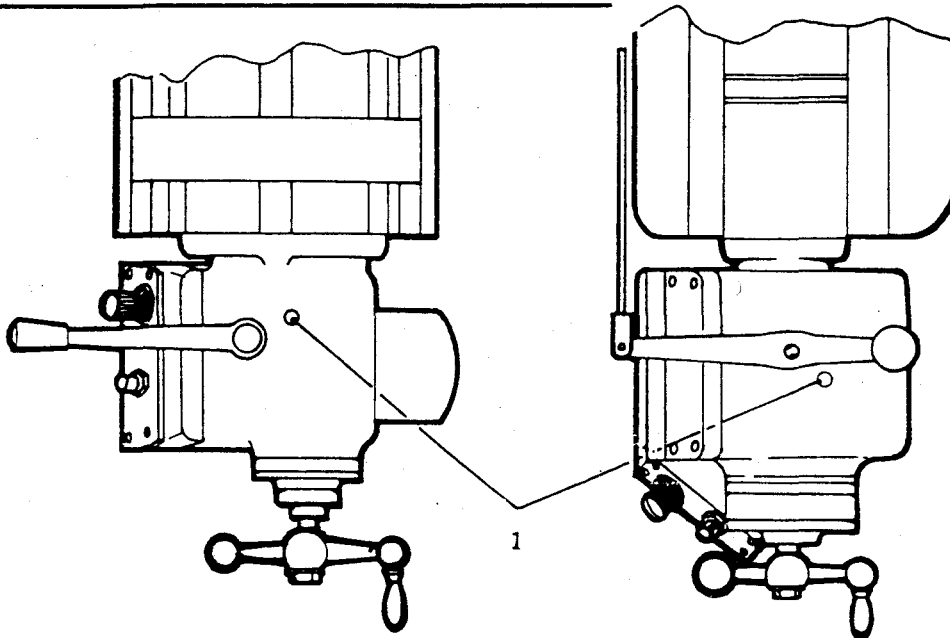

FREQUENCY	LUBRICATE	LUBRICANT	QUANTITY	LUB. AT
Check Weekly	Spiroid Gears	Mobilube HD140 (see page 6-7)	Top-up to oil sight level	1

MECHANICAL FEED

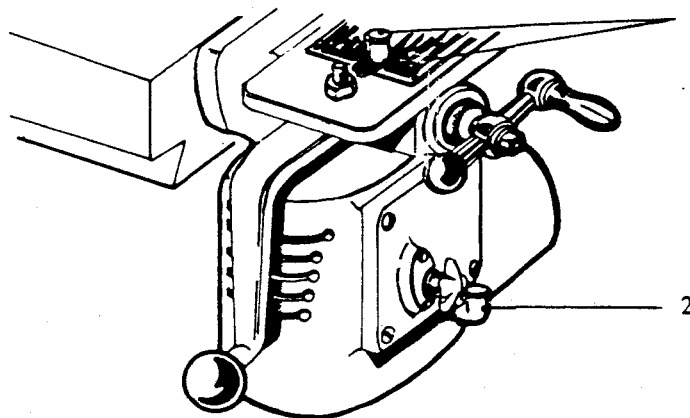

FREQUENCY	LUBRICATE	LUBRICANT	QUANTITY	LUB. AT
Daily	Drive bevel gears	Vactra Heavy/ Medium	2 drops	1
Check Weekly	Wormwheel & change gears	Vactra Heavy/ Medium	Top-up to oil sight level	2

Lubrication

M'HEAD

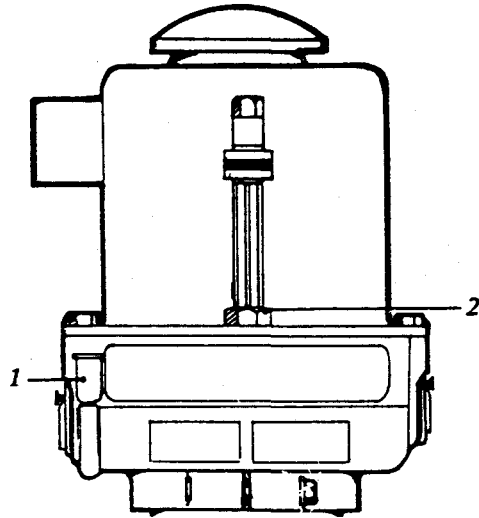

FREQUENCY	LUBRICATE	LUBRICANT	QUANTITY	LUB. AT
Twice Weekly	Spindle Bearings	Mobil Vactra Heavy/Medium	Top-up	1
Weekly	Draw Bar Nut	Vactra Oil No.2	5-10 drops	2

E'HEAD

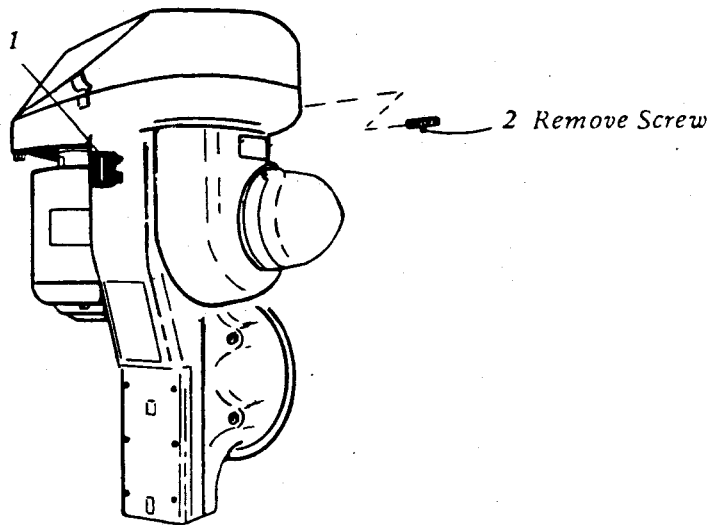

FREQUENCY	LUBRICATE	LUBRICANT	QUANTITY	LUB. AT
Daily or Weekly if in full use	Ram & Connecting Rod	Mobil Vactra Heavy/Medium	Top-up	1
Every 6 months	Worm Drive	Mobil 600 Super Cylinder Oil	Top-up when vertical	2

Maintenance

May We Suggest That.

Before attempting any maintenance in the interests of safety you isolate the machine electrically and in the interests of efficiency you read the relevant section of this manual.

When ordering replacement parts please quote:-

- THE MACHINE SERIAL No. situated on the left hand side of the column.
- THE HEAD SERIAL No. found on the front of the Belt Housing.
- ITEM NUMBER.
- COMPUTER NUMBER.
- PART NUMBER.
- DESCRIPTION.
- QUANTITY.

Introduction

Maintenance

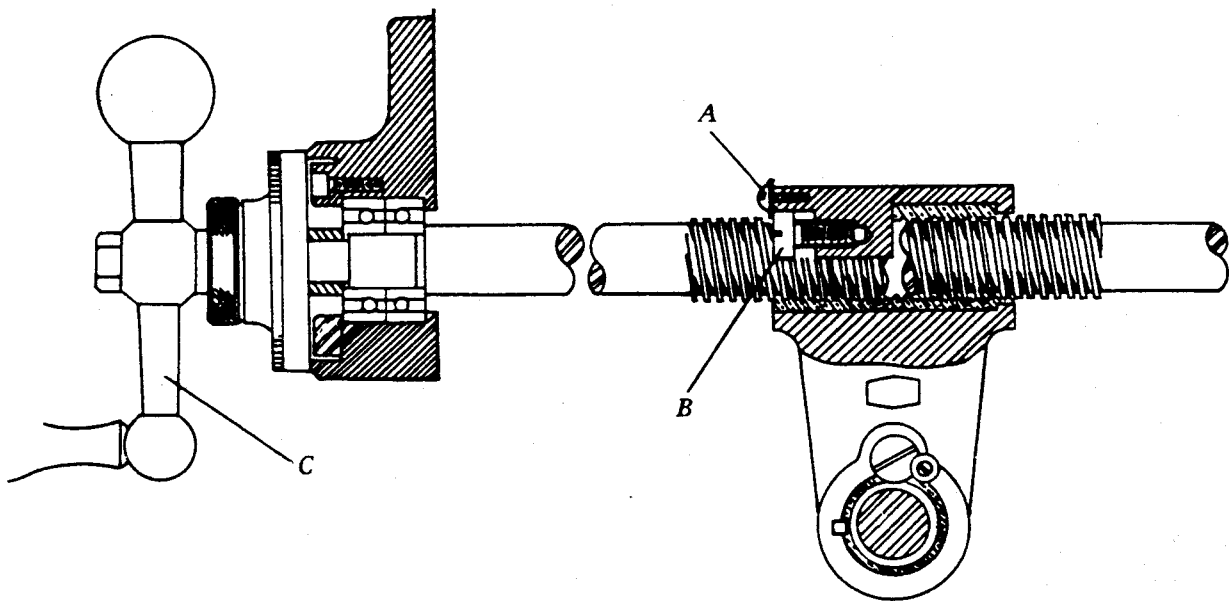

BACKLASH ADJUSTMENT

1. Crank the table to the left.
2. Withdraw screw 'A' $\frac{1}{2}$ a turn.
3. Tighten screw 'B' whilst slowly turning handle 'C' until .004" or .005" is obtained.
4. Finally lock screw 'A' on to 'B'.

Maintenance

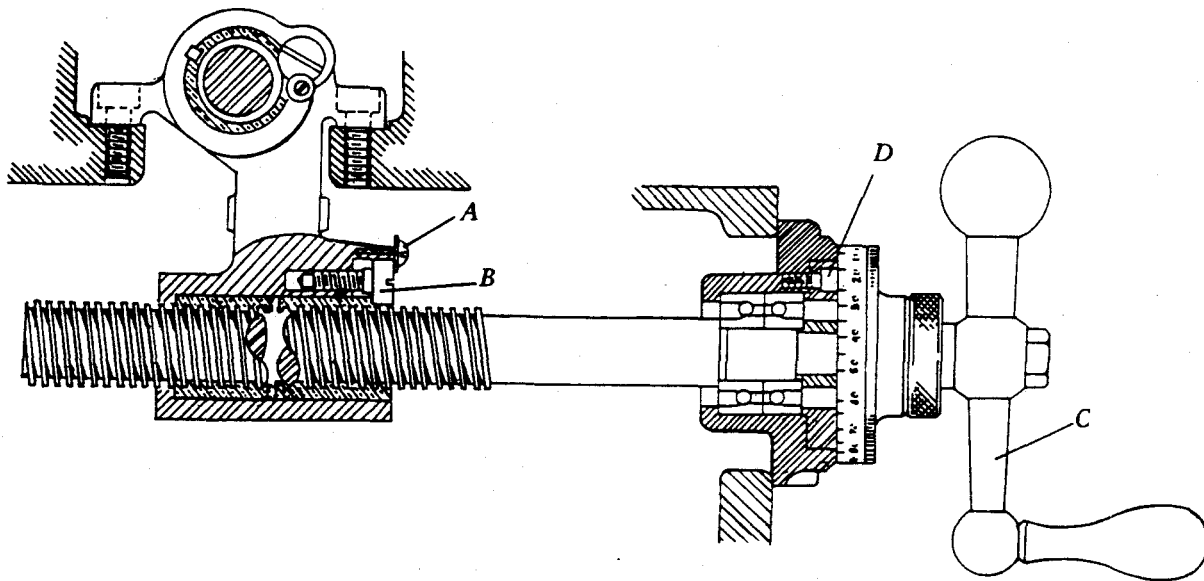

BACKLASH ADJUSTMENT

1. Crank the saddle to Mid position.
2. Withdraw 4 screws 'D'.
3. Pull the saddle forward to expose screws 'A' & 'B'.
4. Withdraw screw 'A', $\frac{1}{2}$ a turn.
5. Whilst slowly turning handle 'C' tighten screw 'B' until .004" or .005" is obtained.
6. Lock screw 'A' onto 'B'.
7. Finally crank the saddle to the front of the knee and replace 4 screws 'D'.

4.2 Cross Screw Assembly

Maintenance

a) Table Saddle Ways

1. Remove all swarf from area.
2. Turn the table gib screw clockwise whilst moving the table until slight drag is felt

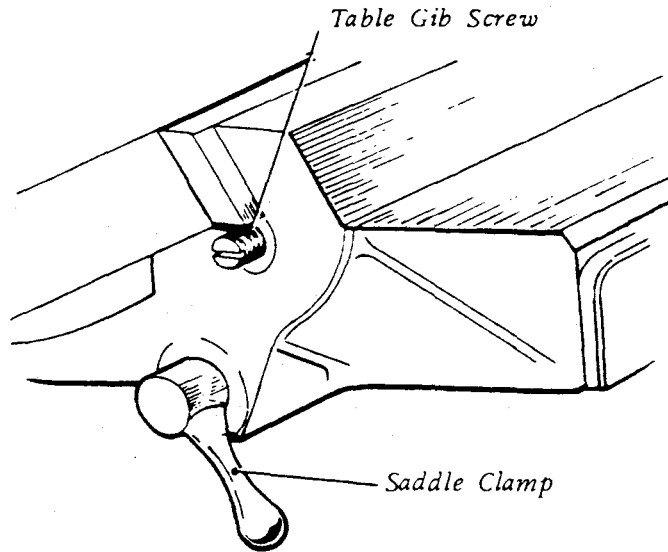

b) Saddle Knee Ways

1. Remove all swarf from area.
2. Remove chip wiper guards and felt.
3. Turn gib adjusting screw clockwise whilst moving the saddle until slight drag is felt.
4. Ensure chip wiper guard and felt are replaced.

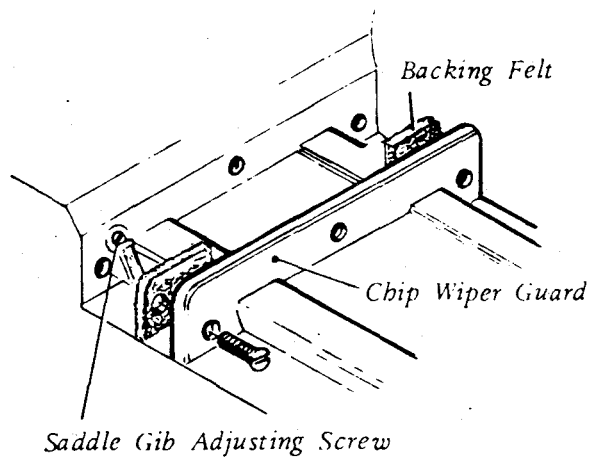

c) Knee Column Ways

1. Remove all swarf from area.
2. Remove chip wiper guard.
3. Remove felt.
4. Turn gib adjusting screw clockwise whilst moving knee until slight drag is felt.
5. Ensure chip wiper guard and felt are replaced.

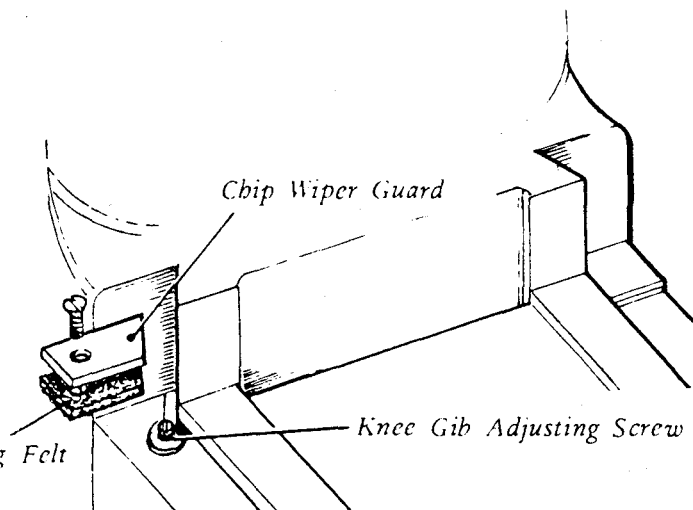

Maintenance

VEE AND TIMING BELT REPLACEMENT

1. Isolate machine.
2. Remove belt guards.
3. Remove drawbar.
4. Remove motor.
5. Lower quill to full extension.
6. Remove 6 screws 'A'.
7. Remove belt housing 'B', tap to withdraw from dowels.
8. The belts may now be changed
9. Refit belt guards.

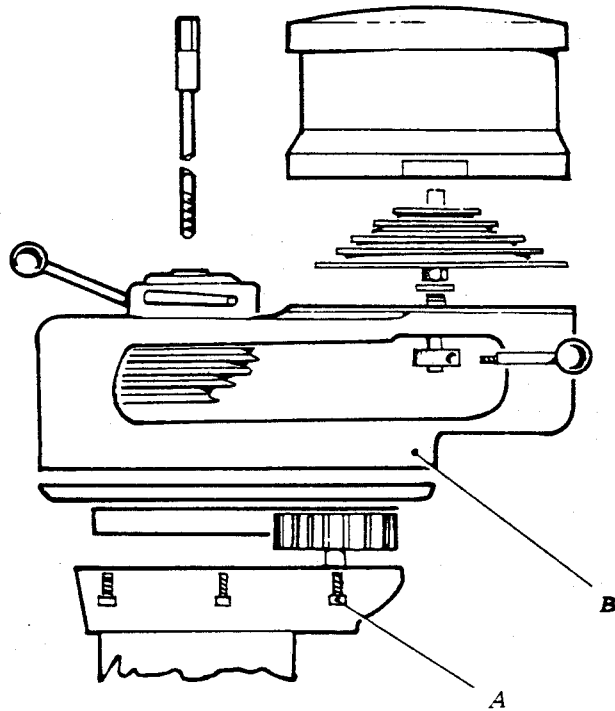

IMPORTANT to conform to Health & Safety at Work Act.

BRAKE SHOE REPLACEMENT

Repeat sequence 1 to 6 above.

1. Remove 2 screws 'A'.
2. Remove 2 screws 'B'.
3. Push bearing hub 'C' clear of housing.
4. Remove 3 screws 'D'.
5. Replace shoe.
6. Ensure screws 'D' are fully tightened and locked with washers and nuts.

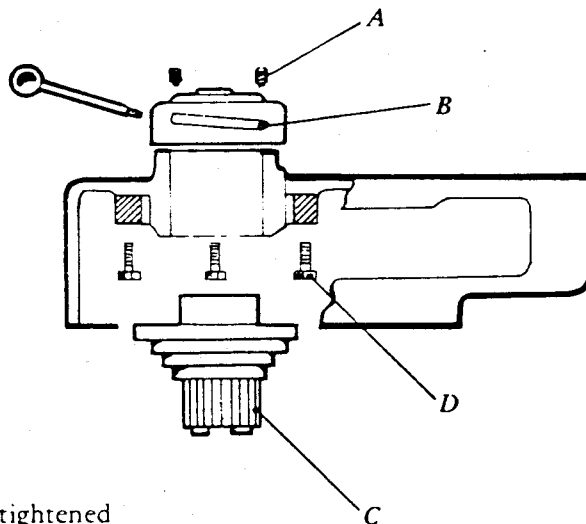

Maintenance

BALANCE SPRING REPLACEMENT

1. With quill at top of movement apply quill lock.
2. Remove screw 'A', hub 'B', and key 'C'.
3. Remove screws 'D', allowing housing to rotate slowly releasing spring tension.
4. Lift end of spring from peg on the pinion shaft.
5. Rotate housing 'E' anti-clockwise from head casting.
6. Remove spring from housing and replace.
7. Refit spring to main housing casting turning housing clockwise until spring locates on peg in pinion shaft.

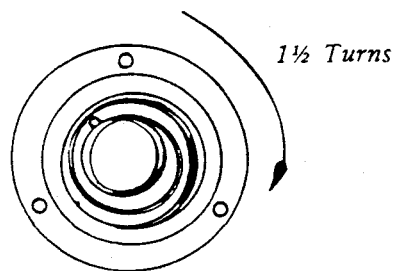
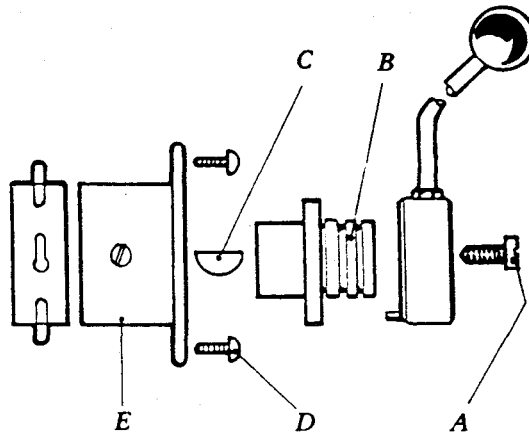

FEED TRIP ADJUSTMENT

1. Release locknut 'A'.
2. Engage trip handle 'C'.
3. Adjust micro nuts against quill stop 'B'.
4. Slowly turn adjusting screw 'D' until lever 'C' trips.
5. At this point secure locknut 'A'.
6. Check that smart trip action is obtained.

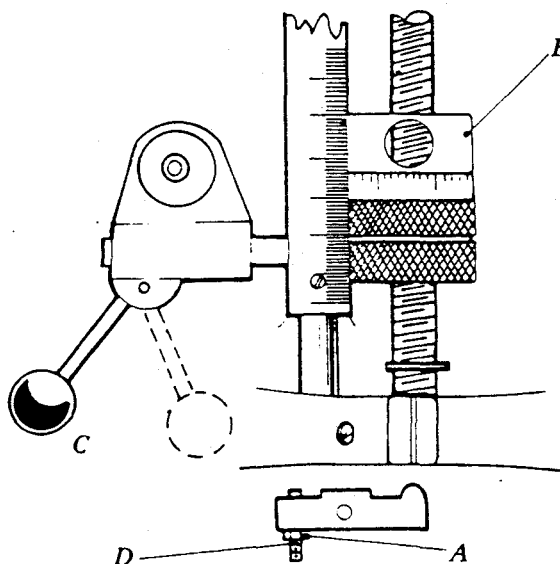

Maintenance

COLLET ALIGNING SCREW REPLACEMENT

1. Use felt pen, mark reference line on quill and nose cap 'B'.
2. Remove set screw 'A'.
3. Unscrew nose cap 'B'.
4. Remove lock screw 'C' and collet aligning screw 'D'.
5. Replace 'D'; insert R.8 collet and check that the dog on the end of the screw does not foul on the bottom of the guide slot.
6. Replace lock screw 'C'.
7. Replace nose cap 'B'; check felt pen markings for correct alignment.
8. Replace set screw 'A'. Caution do not overtighten as this will cause distortion.
9. Check gap 'E'. (.003" = .08mm)

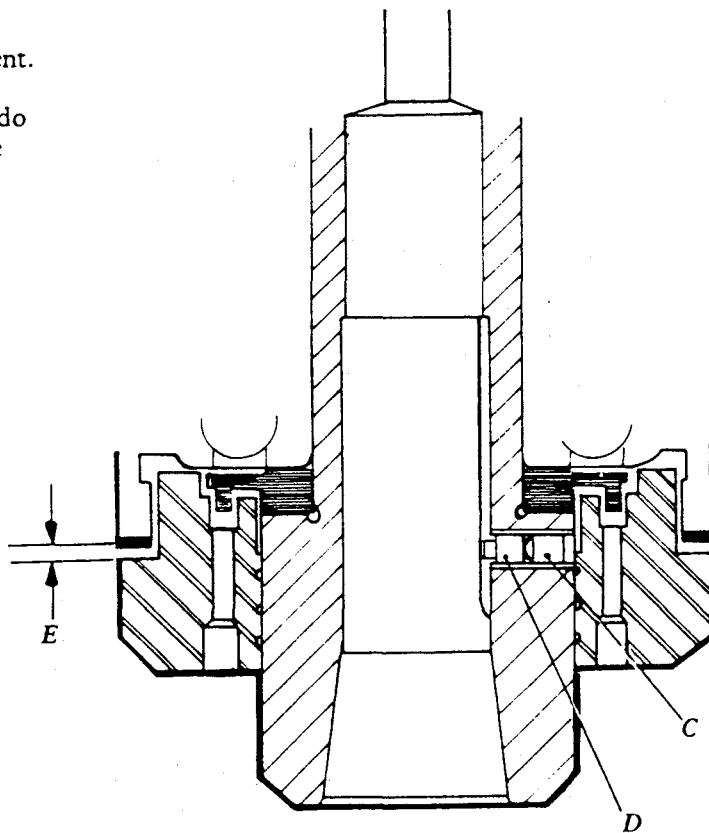
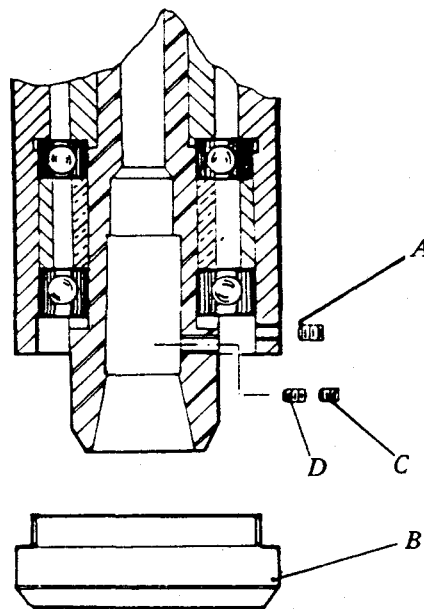

Maintenance

QUILL REMOVAL

1. Isolate machine.
2. Remove belt guards.
3. Remove motor.
4. Remove drawbar.
5. Fully extend quill.
6. Remove 3 nuts 'A'.
7. Remove top section complete.
8. Remove 1 screw 'B' from top of quill.
9. Remove clock spring housing 'C' - see instruction on replacing spring page 4-5.
10. Refit belt guards.

IMPORTANT to conform to Health & Safety at Work Act.

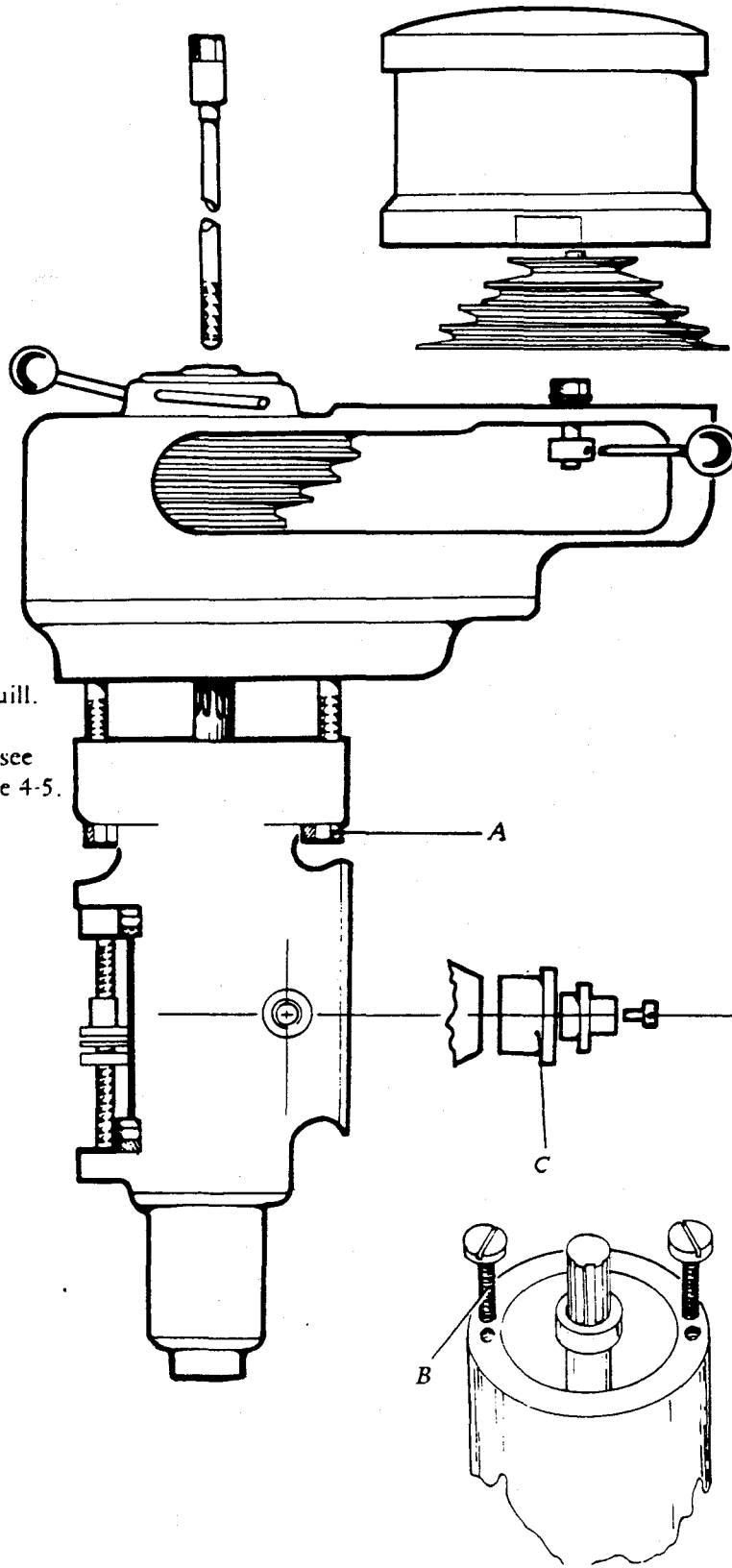

Maintenance

11. Remove screw 'D' and ball reverse lever 'E'.
12. Remove circlip 'F', screw 'G' and arm 'H'.
13. Thread shaft 'J' through micro nuts and remove.
14. Remove screw 'K' and stop 'L'.
15. Remove quill.
16. Clean all areas, oil liberally and reassemble.
17. Check correct operation of feed trip linkage. See instruction on page 4-5

Re-assembly of spline alignment. see page 2-2.

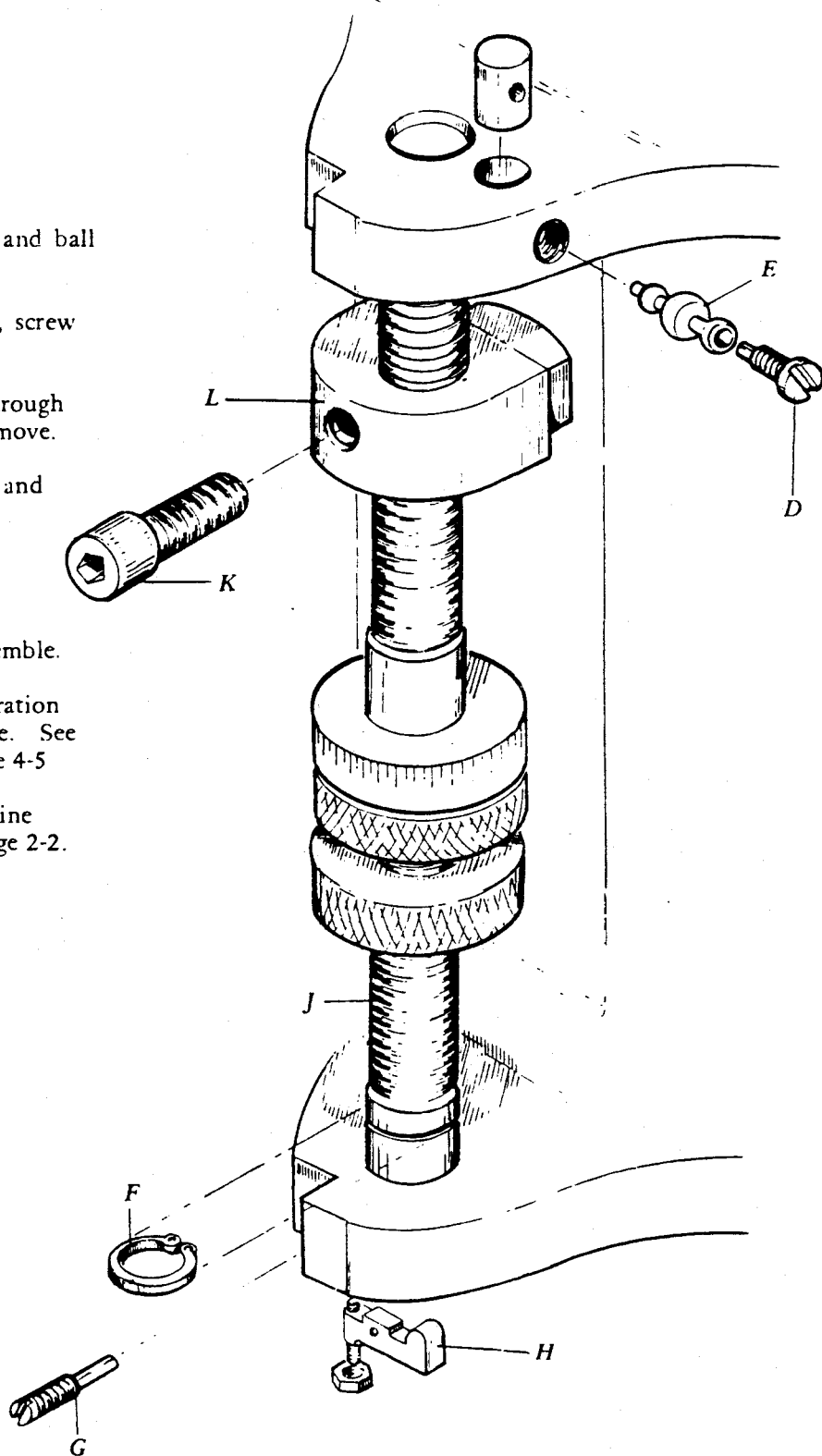

4.7 J and 2J2 - Head

Maintenance

MOTOR REMOVAL

1. Run head to adjust to lowest speed.
2. Isolate machine.
3. Remove 3 screws 'A' & cover 'B'.
4. Using the two screws 'A', compress spring 'C'.
5. Rotate the speed changer to the highest speed.
6. Remove the reversing switch from the belt housing.
7. Remove the two locking nuts 'D'.
8. Lift the motor and rest the case on stud 'E'.
9. Ease the belt over the lower drive disc and remove the motor.

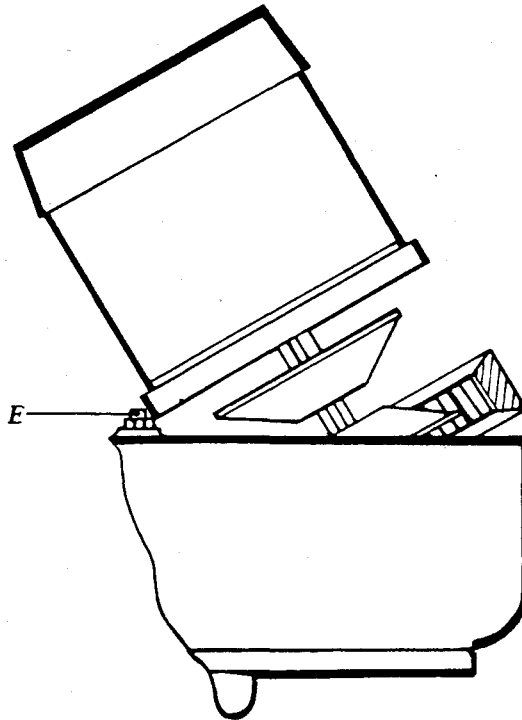
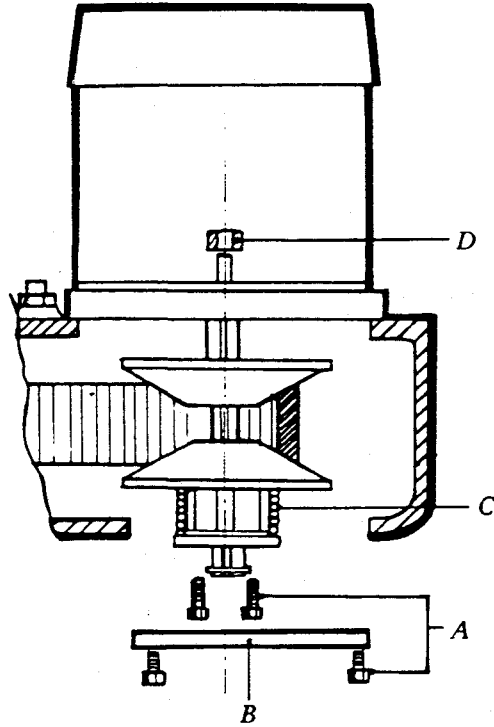

Maintenance

DRIVE BELT REPLACEMENT

1. Remove the motor as described on page 4-8
2. Remove the three screws 'A'; insert into the adjacent tapped holes and withdraw bearing housing 'B'.
3. Remove the two screws and the bushes 'C'.
4. Remove four screws 'D' and one screw 'E'.
5. Remove four screws securing the speed changer 'F'.
6. Remove top housing 'G'; tap to clear the dowels.
7. Replace the belt.

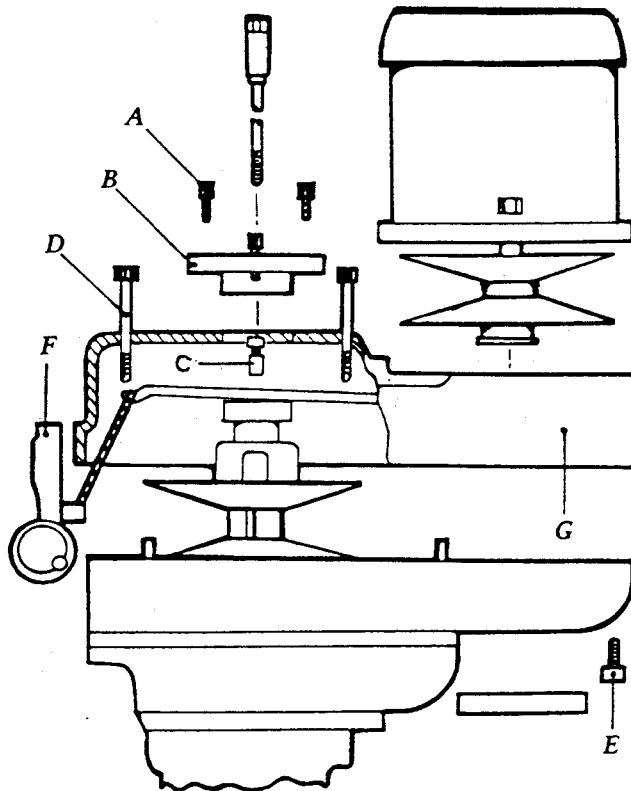

TIMING BELT REPLACEMENT

1. Remove the motor.
2. Lower the quill to full extent.
3. Remove the two lower cap screws 'A' from the speed changer housing.
4. Remove the four cap screws 'B'.
5. Remove the top assembly 'C' and tap to clear dowels.
6. Replace the belt.

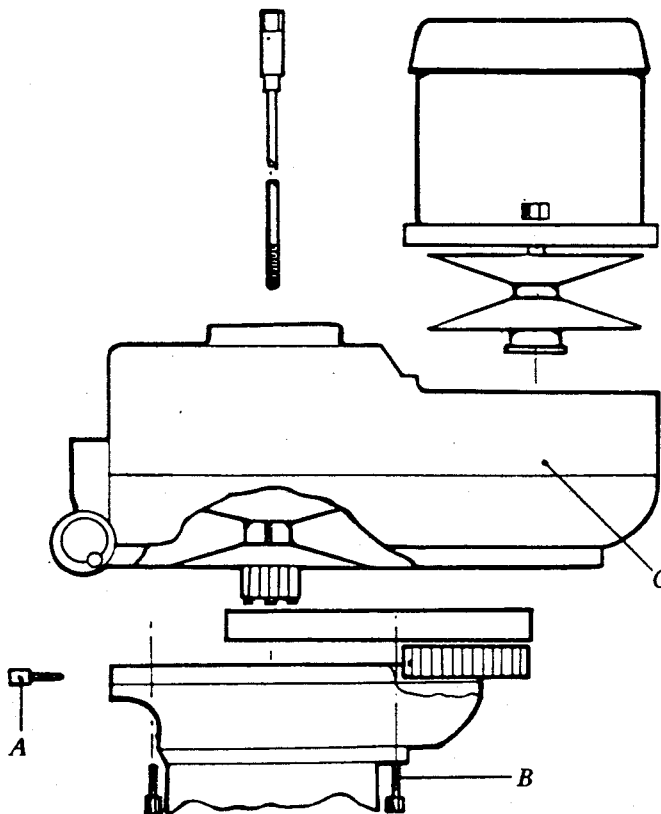

Maintenance

BRAKE SHOE REPLACEMENT

1. Remove the top section.
2. Remove the two screws 'A'.
3. Remove the clutch hub assembly 'B'.
4. Replace the brake shoes 'C'.
5. Remove the bearing, drive discs and circlips from the hub assembly 'B'.
6. Replace the bearing and housing 'D'.
7. Thread the hub 'B' through the bearing and reassemble the discs etc.

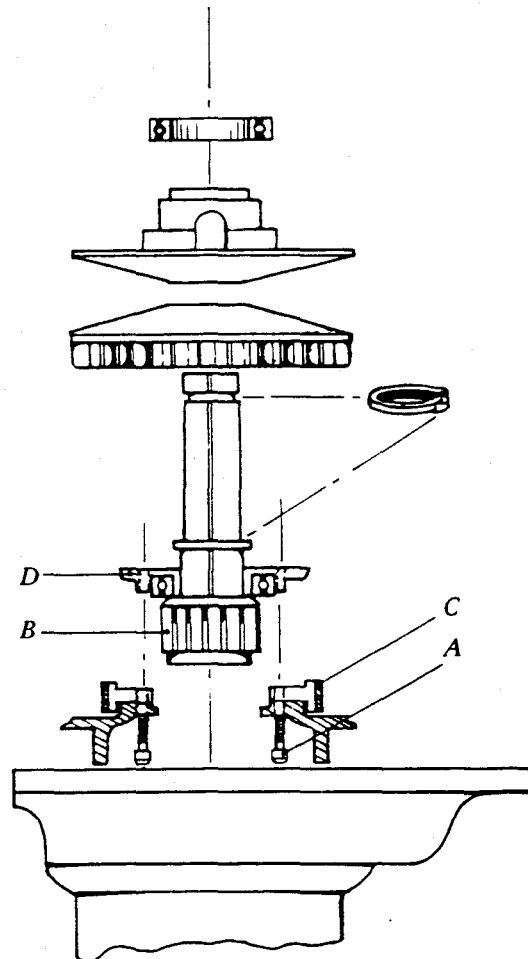

Maintenance

VEE BELT REPLACEMENT

1. Isolate machine.
2. Slacken belt tension by unlocking nuts 'A'.
3. Remove guards.
4. Remove the vee belt downwards from the rear pulley lifting the motor off if necessary.
5. Remove vee belt from pulley by lifting upwards and passing the belt through the recess at the top of the belt housing.
6. Pass the new vee belt through the opening at the top of the belt housing, over the drawbar and pulley, feeding the belt onto the motor pulley.
7. Refit belt guards.

IMPORTANT to conform to Health & Safety at Work Act.

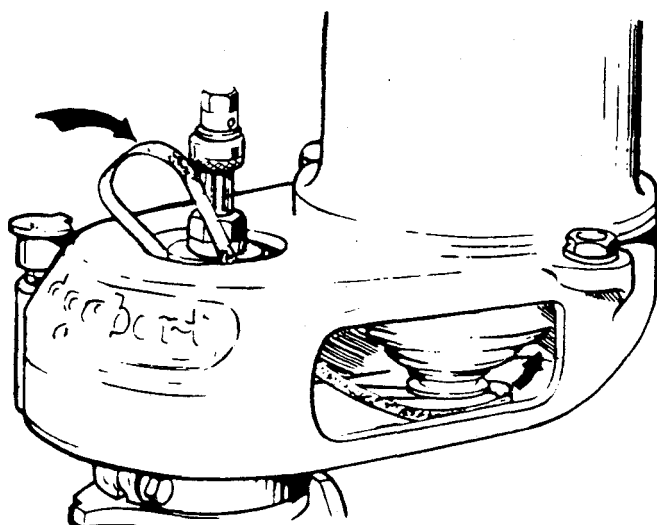
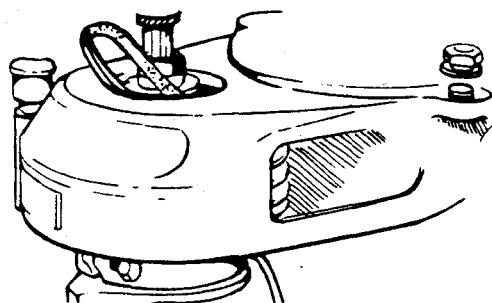
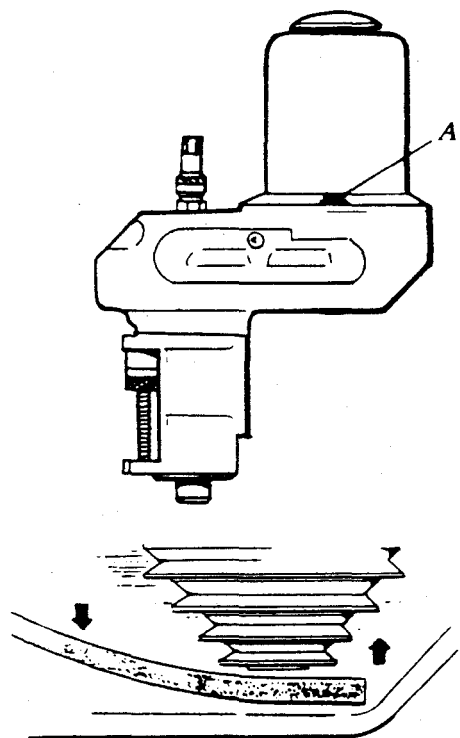

Maintenance

QUILL REMOVAL

1. Isolate machine.
2. Remove belt guards
3. Unlock hex nuts 'A' and remove motor.
4. Remove drawbar.
5. Slacken $\frac{1}{2}$ " hex headed screw 'B'.
6. Remove belt housing unit 'C' from quill housing 'D' by lifting upwards.
7. Refit belt guards

IMPORTANT to conform to Health & Safety at Work Act.

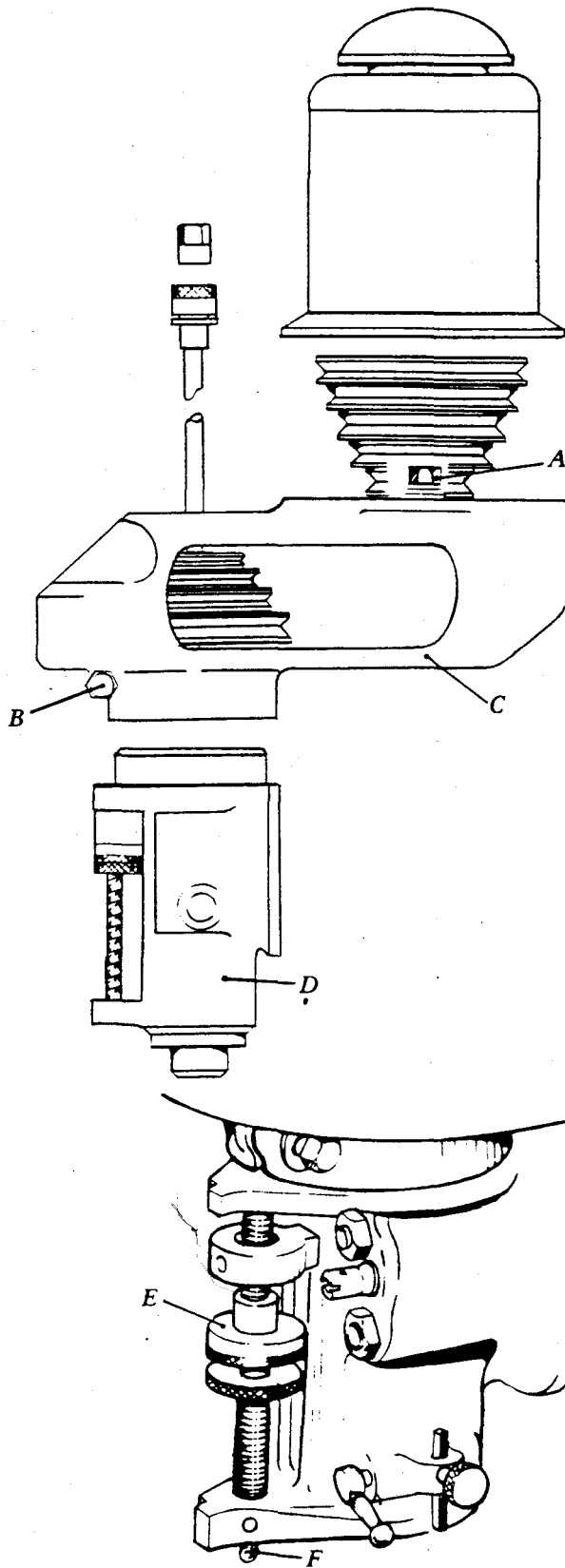

6. Turn micronut 'E' to the top of the micro-screw.
7. Slacken hollow set screw 'F' in bottom of projection.
8. Using a large screw driver engage in bottom of micro-screw (RH. thread) and remove screw downwards.

Maintenance

QUILL REMOVAL CONT.

9. Remove ½" allen cap screw 'G' from microstop.

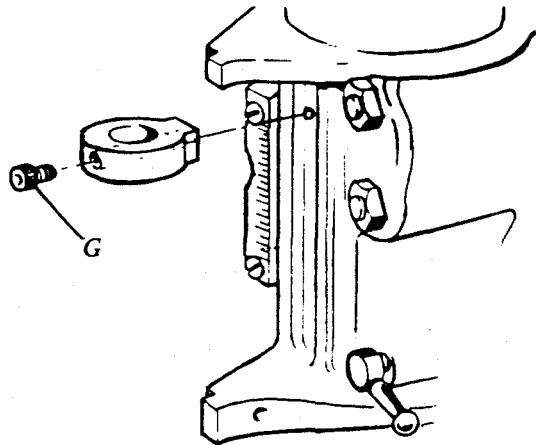

10. Push quill upwards to limit of travel and remove skirt 'H'.

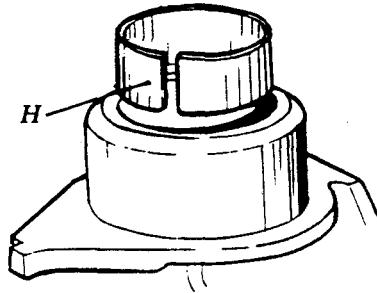

11. Remove quill feed clutch knob 'J' and bolt 'K'.
12. Remove 3 screws 'L' and spring cover 'M'.
13. Remove outer end of spring 'N' with thin pliers.
14. The quill is now free to be drawn out from the nose cap end.

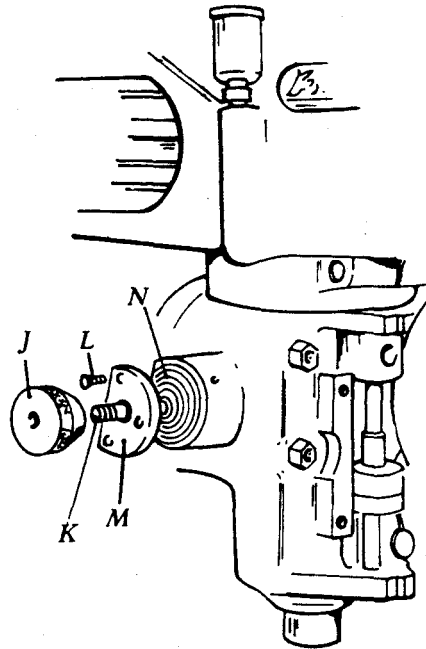

Maintenance

REMOVING MOTOR

1. Slacken the two hex nuts 'A' on either side of belt housing.
2. Remove motor.

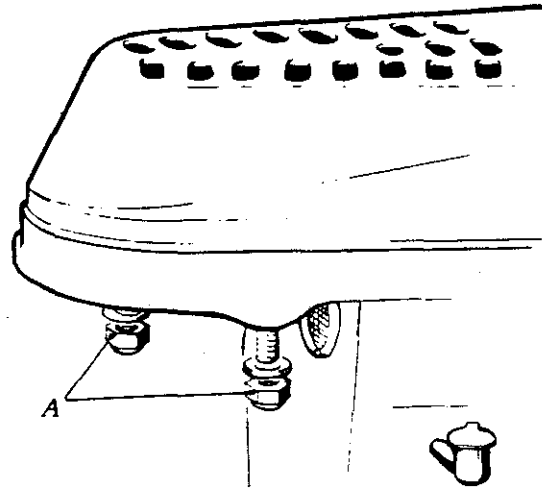

CHANGING SPEED

1. To change speed slacken the two hex nuts 'A' and move motor forward.
2. Open the belt housing cover 'B', and change speed by moving pulley 'C' then re-tension.

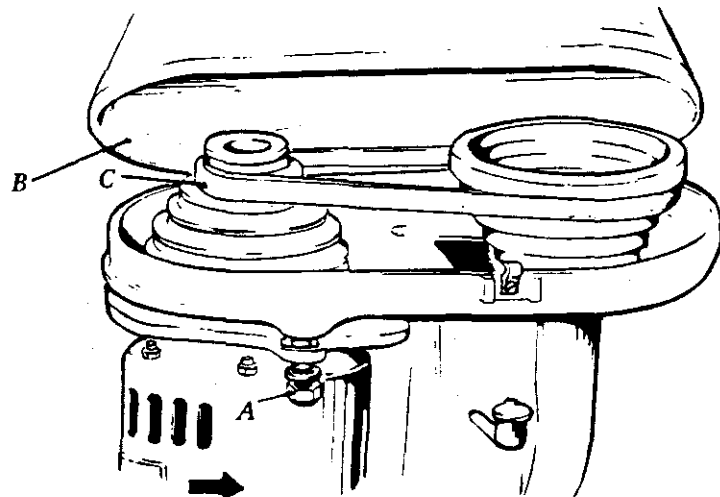

REMOVING REDUCTION DRIVE UNIT OR RAM

1. Slacken hex nuts 'A' and remove motor.
2. Remove vee belt pulley 'C'.
3. Remove two screws 'D' from air vent cover 'E' and bring into view the top end of the connecting rod.
4. Remove two flat headed screws 'F' and bearing retaining washer 'G'.
5. Remove three socket screws 'H' and split the gearhousing from the ram housing.
6. The reduction drive unit may now be removed complete whilst the ram may be drawn out downwards from the clapperbox end.

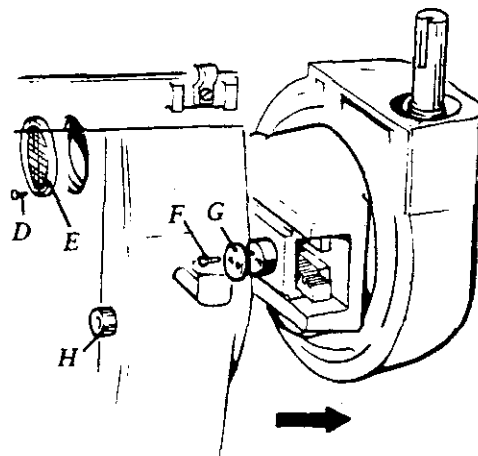

Maintenance

CHANGING THE GEARCASE OIL

Drain and refill gearcase with $\frac{1}{2}$ pint of sony 600W cylinder oil or equivalent after first two months of normal service and twice yearly thereafter. Oil should flow when both plugs are removed and attachment inverted in the vertical axis, be sure to replace plugs in proper holes. Top plug is drilled for vent.

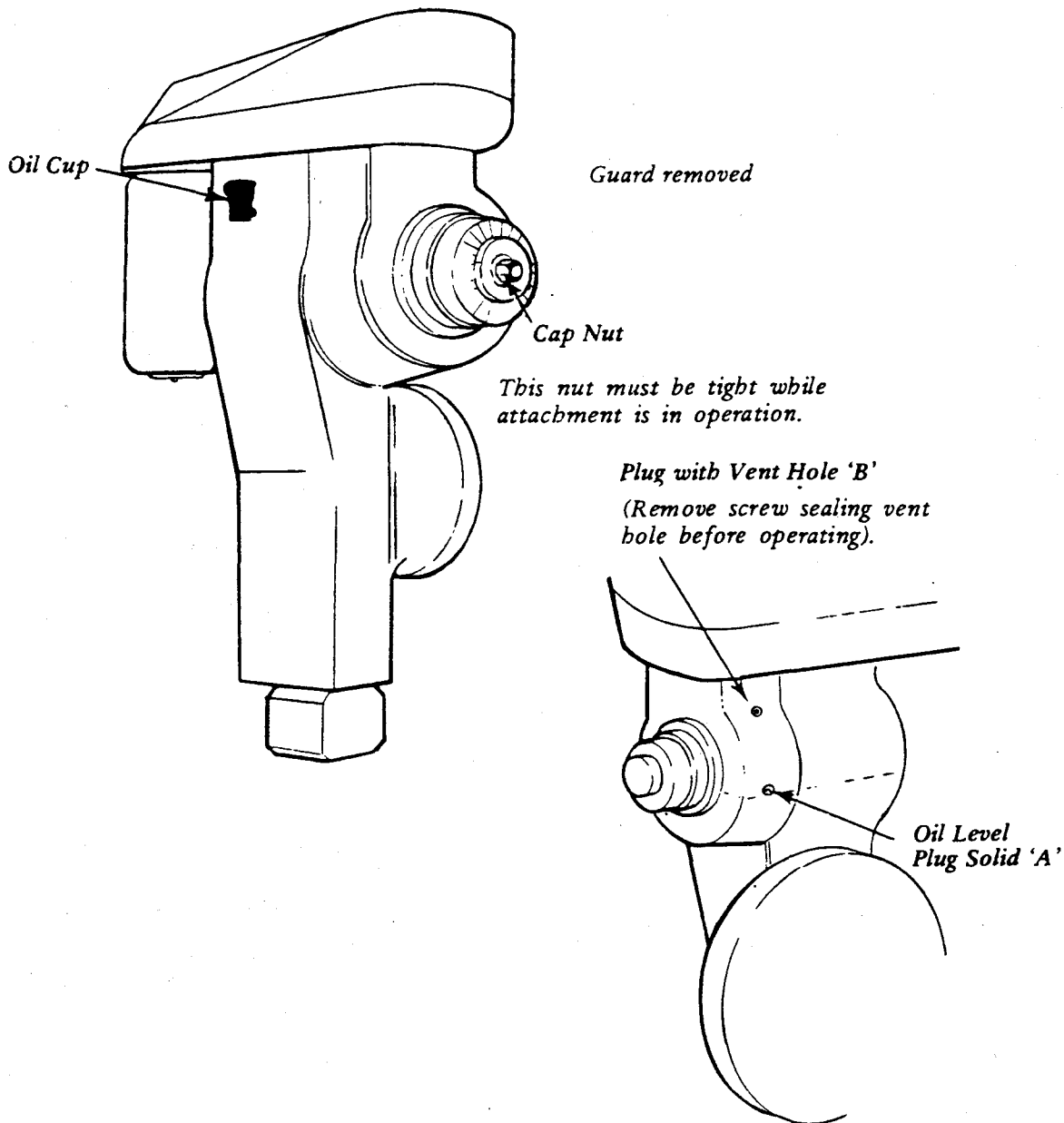

**Specification
and
Extra Equipment**

NOTES



Specification

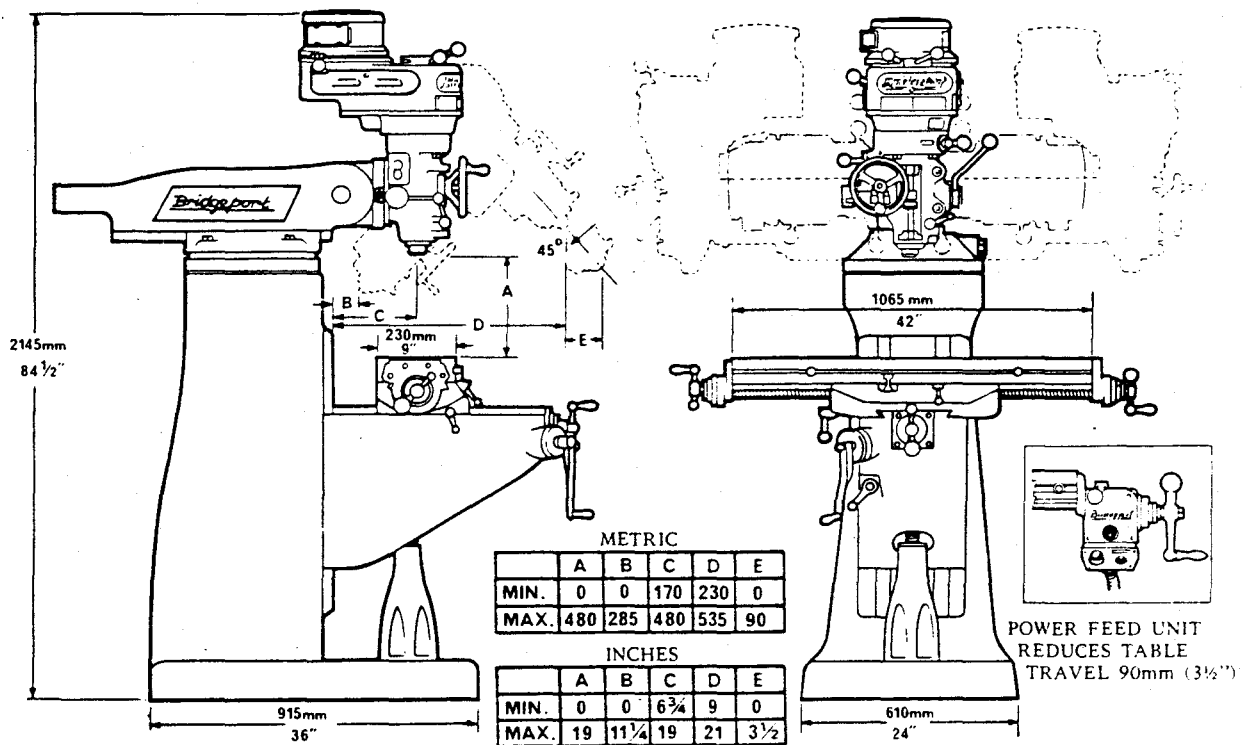

METRIC					
	A	B	C	D	E
MIN.	0	0	170	230	0
MAX.	480	285	480	535	90

INCHES					
	A	B	C	D	E
MIN.	0	0	6 3/4	9	0
MAX.	19	11 1/4	19	21	3 1/2

Table Size	1065 x 230 mm	42" x 9"
Longitudinal Traverse Hand only	760 mm	30"
Power Feed fitted	675 mm	26 1/2"
Cross Traverse	305 mm	12"
Vertical Traverse	405 mm	16"
Number of Tee Slots	3	3
Width and Centres	15.9 mm at 63.5 mm	5/8" at 2 1/2"
Ram Movement	305 mm	12"
Spindle Speeds Number	15	15
Range rpm	67-4600	67-4600
Spindle Centre to Column Face	170-480 mm	6 3/4"-19"
Spindle to table	0-480 mm	0-19"
Quill Feeds per rev of Spindle	.04 mm, .08 mm, .15 mm	0.0015"-0.003"-0.006"
Motor	1/4-1 1/2 kw	1-2 h.p.
Shipping Particulars Space Occupied	3.26 cu.m	115 cu.ft.
Nett Weight (Basic Machine)	889 kg	1960 lb
Gross Weight (Basic Machine)	1168 kg	2576 lb

- Machines can also be fitted with a 915 x 230 mm (36" x 9") or a 1220 x 230 mm (48" x 9") table with a longitudinal traverse of 610 mm (24") and 915 mm (36") respectively. If longitudinal power feed unit is fitted the table traverse is reduced by 90 mm (3 1/2").
- Machines can be fitted with a tee ram to allow up to 3 milling heads to be mounted side by side.

Specification

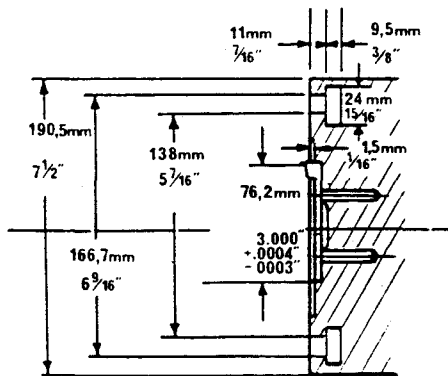
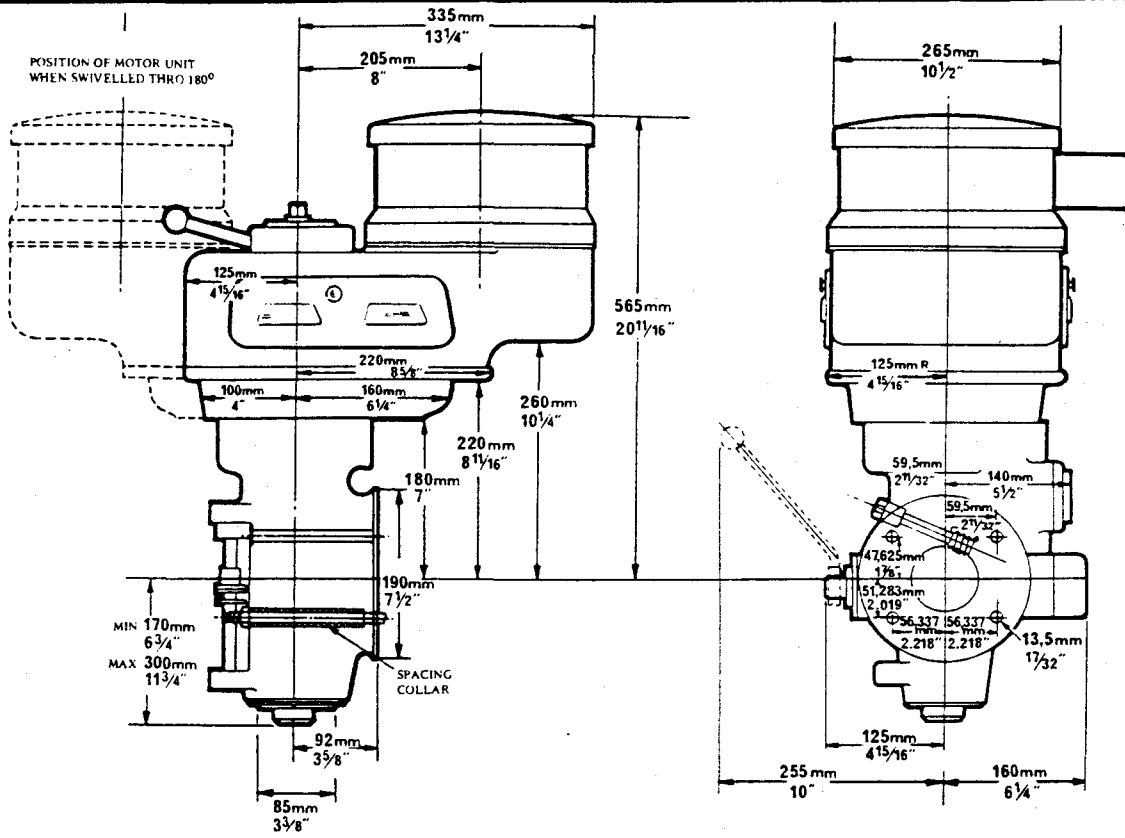

Details of mounting and swivelling face.

Spindle Taper	R8				R8			
	High Range				Low Range			
Spindle Speeds—rpm	134	230	360	550	67	115	180	275
	1110	1840	3000	4600	550	920	1500	2300
Motor	1/4 - 1 1/2 kw				1-2 h.p.			
Quill Travel	125 mm				5"			
Power Feed of Quill	0.05 mm				0.0015"			
per rev of Spindle (3 rates)	0.08 mm				0.003"			
	0.15 mm				0.006"			
Collet Capacity	2-20 mm x 1 mm				1/8" - 3/4" - 1/16"			
Weight	76 kg				168 lb			

5.2 Bridgeport J - Head

Specification

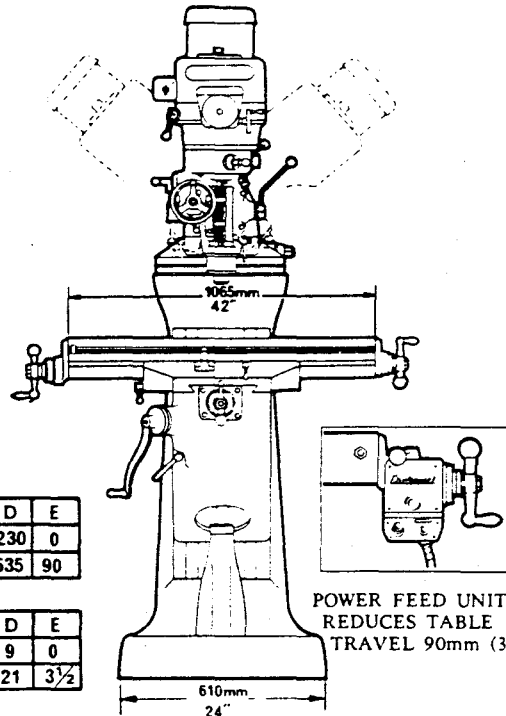
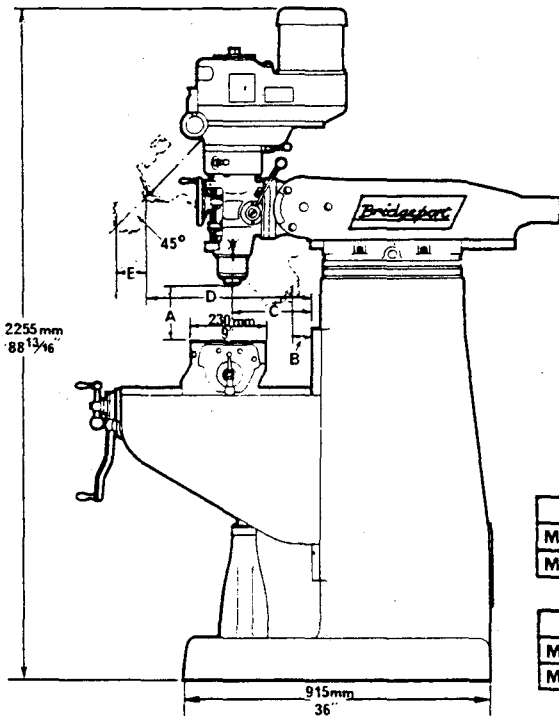

METRIC					
	A	B	C	D	E
MIN.	0	0	170	230	0
MAX.	480	285	480	535	90

INCHES					
	A	B	C	D	E
MIN.	0	0	6 3/4	9	0
MAX.	19	11 1/4	19	21	3 1/2

Table Size	1065 x 230 mm	42" x 9"
Longitudinal Traverse Hand only	760 mm	30"
Power Feed fitted	675 mm	26 1/2"
Cross Traverse	305 mm	12"
Vertical Traverse	405 mm	16"
Number of Tee Slots	3	3
Width and Centres	15.9mm at 63.5 mm	5/8" at 2 1/2"
Ram Movement	305 mm	12"
Spindle Speeds - rpm (infinitely variable)	50-3750	50-3750
Spindle Centre to Column Face	170-480 mm	6 3/4"-19"
Spindle to Table	0-480 mm	0-19"
Quill Feeds per rev of Spindle	.04 mm, .08 mm, .15 mm	0.0015"-0.003"-0.006"
Shipping Particulars Space Occupied	3.26 cu.m	115 cu.ft.
Nett Weight (Basic Machine)	900 kg	1988 lb
Gross Weight (Basic Machine)	1180 kg	2604 lb

- Machines can also be fitted with a 915 x 230 mm (36" x 9") or a 1220 x 230 mm (48" x 9") table with a longitudinal traverse of 610 mm (24") and 915 mm (36") respectively. If longitudinal power feed unit is fitted the table traverse is reduced by 90 mm (3 1/2").
- Machines can be fitted with a tee ram to allow up to 3 milling heads to be mounted side by side.

Specification

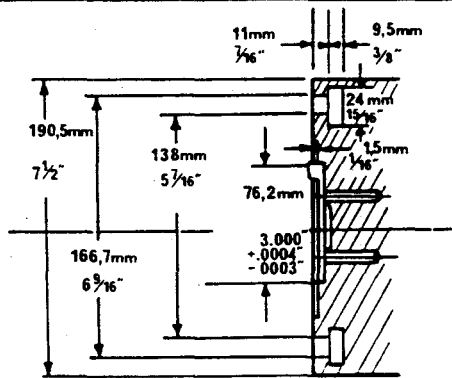
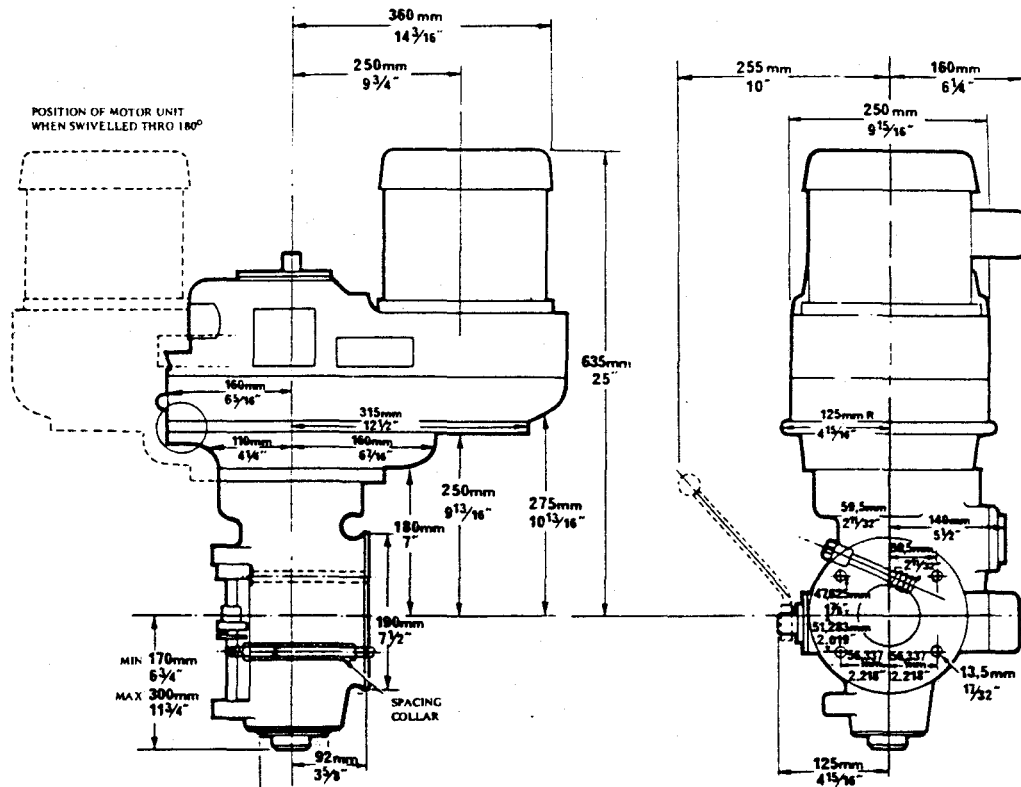

Details of mounting and swivelling face

Spindle Taper	R8	R8
Spindle Speeds—rpm	50—3750	50—3750
Motor	1 1/2 kw	2 h.p.
Quill Travel	127 mm	5"
Power Feed of Quill	0.04 mm	0.0015"
per rev of Spindle (3 rates)	0.08 mm	0.003"
	0.15 mm	0.006"
Collet Capacity	2—20 mm x 1 mm	1/8" - 3/4" x 1/16"
Weight	89 kg	196 lb

5.4 Bridgeport 2J2 - Head

Specification

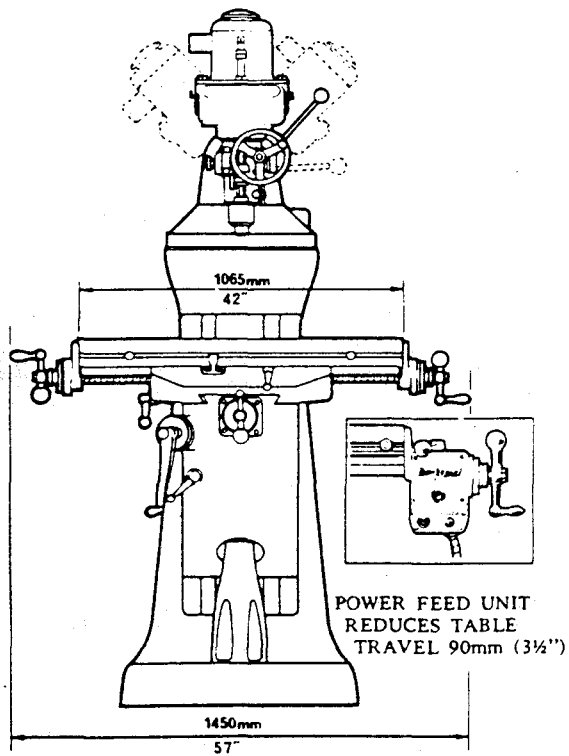
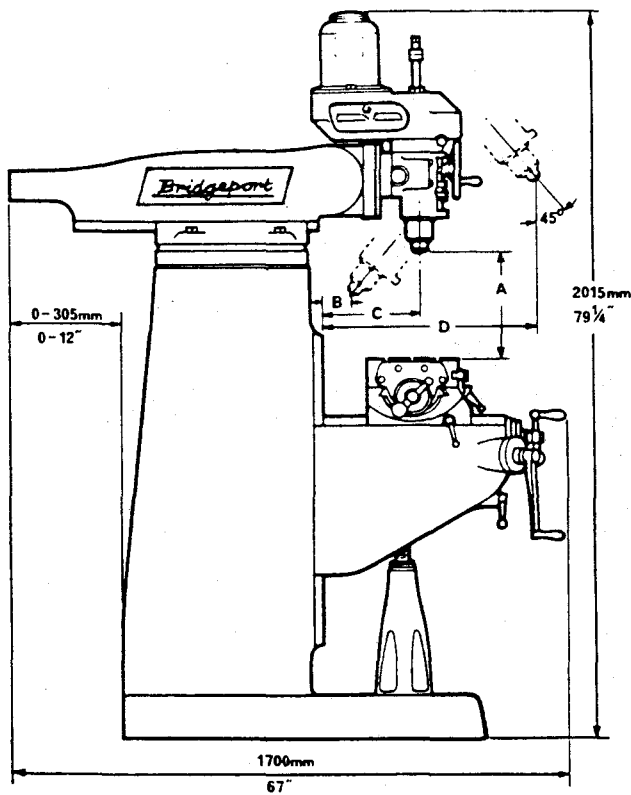

METRIC				
	A	B	C	D
MIN.	95	25	191	234
MAX.	495	343	508	552

INCHES				
	A	B	C	D
MIN.	3 3/4	1	7 1/2	9 1/4
MAX.	19 1/2	13 1/2	20	21 3/4

Table Size	1065 x 230 mm	42" x 9"
Longitudinal Traverse Hand only	760 mm	30"
Power Feed fitted	675 mm	26 1/2"
Cross Traverse	305 mm	12"
Vertical Traverse	405 mm	16"
Number of Tee Slots	3	3
Width and Centres	15.9 mm at 63.5 mm	5/8" at 2 1/2"
Ram Movement	305 mm	12"
Spindle Speeds Number	6	6 (see Note 2)
Range-rpm	330-5100	330-5100
Spindle to Column Face	190-510 mm	7 1/2" - 20"
Spindle to Table	95-495 mm	3 3/4" - 19 1/2"
Motor	1/2 kw	3/4 h.p.
Shipping Particulars Space Occupied	3.26 cu.m	115 cu.ft.
Nett Weight (Basic Machine)	854 kg	1882 lb
Gross Weight (Basic Machine)	1133 kg	2498 lb

1. Machines can also be fitted with a 915 x 230 mm (36" x 9") or a 1220 x 230 mm (48" x 9") table with a longitudinal traverse of 610 mm (24") and 915 mm (36") respectively. If longitudinal power feed unit is fitted the table traverse is reduced by 90 mm (3 1/2").

Specification

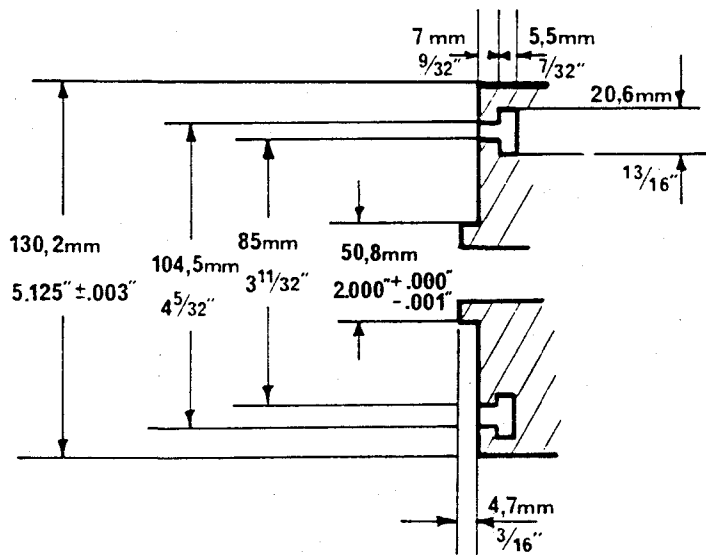
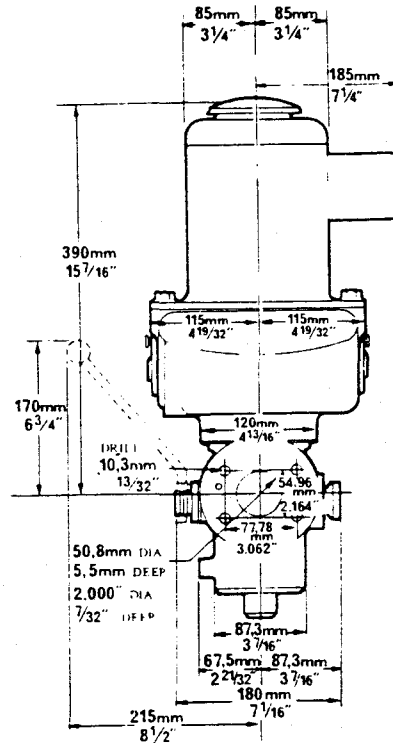
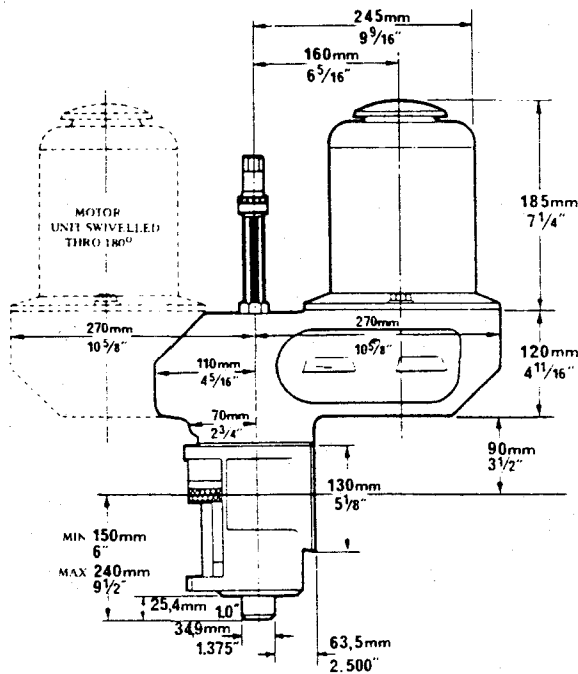

Details of mounting and swivelling face

Spindle Taper
 Spindle Speeds—rpm
 Motor
 Quill Travel
 Collet Capacity
 Weight

No. 2 Morse Taper
 330, 540, 900, 1290, 2625, 5100
 9/16k w. 3/4h.p.
 90 mm 3 1/2"
 2—13 mm x 1 mm 1/16" - 1/2" x 1/16"
 40 kg 90 lb

5.6 Bridgeport M-Head

Specification

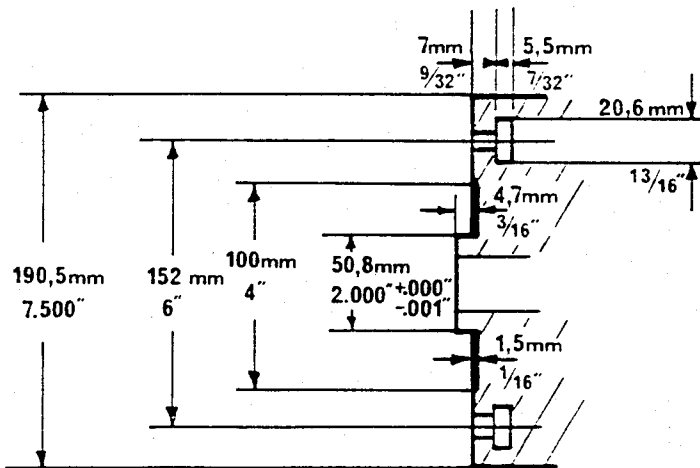
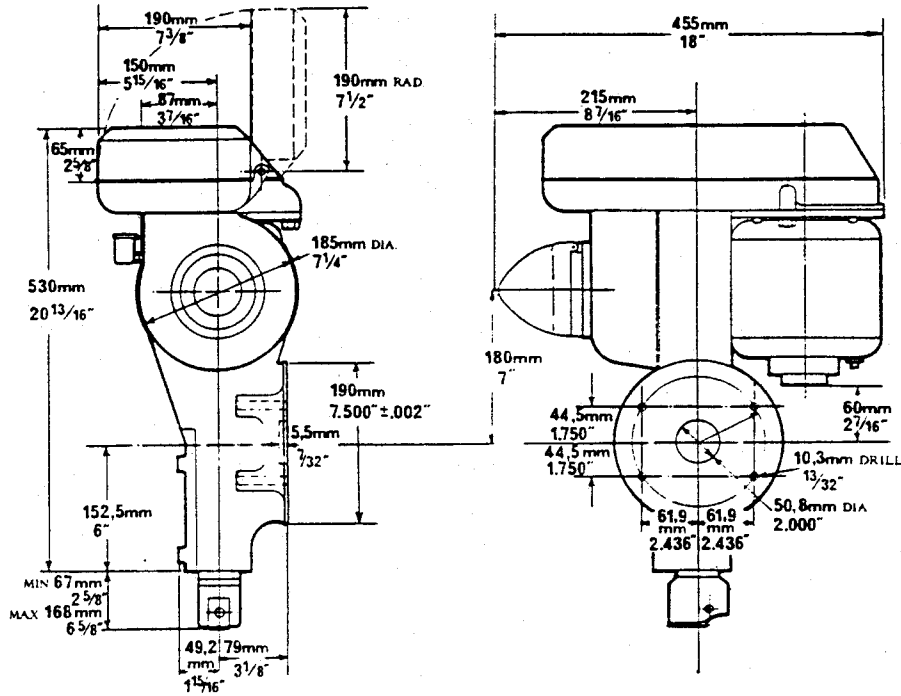

Details of mounting and swivelling face.

Oscillation Rate (Strokes per Minute)		60	85	120
		170	245	350
Motor	1/4kw			1/3 h.p.
Stroke Adjustment	3-100 mm x 3 mm			1/8" - 4" x 1/8"
Tool Capacity Horizontally Mounted	9 mm			3/8"
Vertically Mounted	15 mm			5/8
Weight	51 kg			112 lb

Extra Equipment

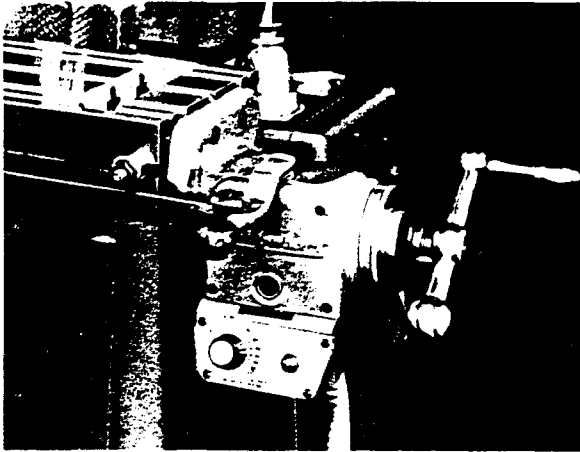

- ▲ 2 Axis Digital Read - Out System
- ◀ Infinitely Variable Longitudinal Power Feed Unit with Rapid Traverse

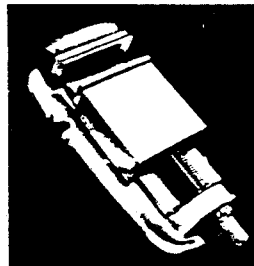

▲ Machine Vices

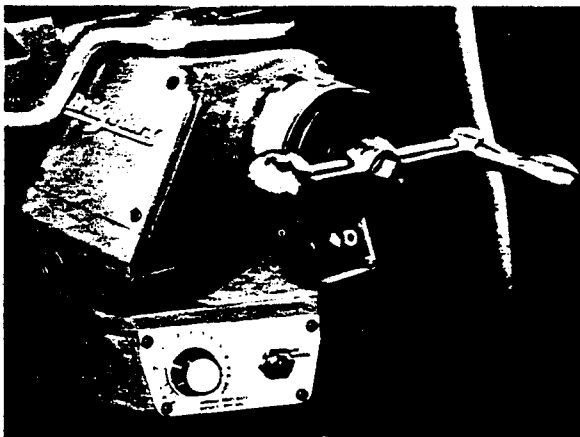

- ◀ Infinitely Variable Cross Feed Power Unit with Rapid Traverse

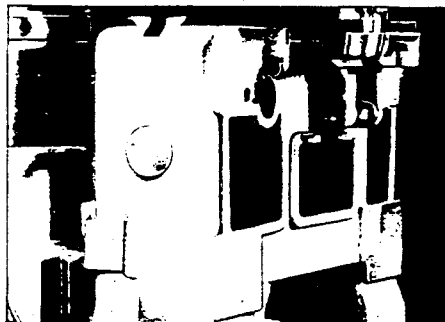

▲ Raiser Blocks



▲ Splash Tray for Base

Extra Equipment

COLLETS

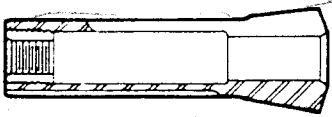

7/16 20THD

ADAPTORS – R8 TAPER

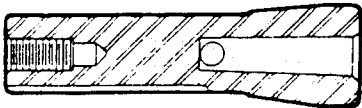

7/16 20THD

A comprehensive range of collets is available to fit J, 2J2 and M heads and right angle attachments.

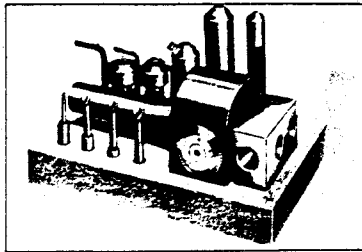

◀ Boring Heads

▶ Hi-Speed Flycutter

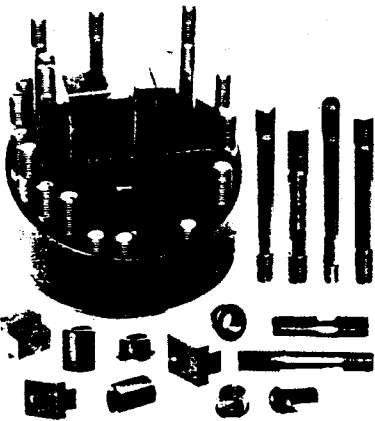
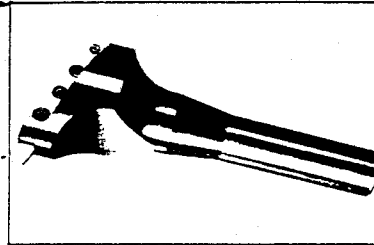

▲ Holding Down Bolts, Clamps and Nuts

STUB ARBORS

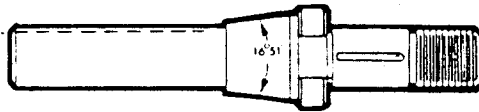

SHELL END MILL ARBORS

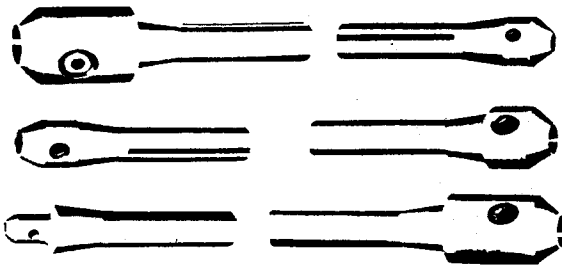
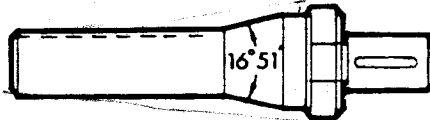
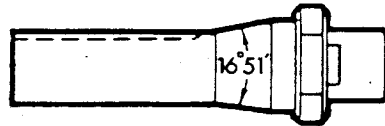

END MILL HOLDERS

5.8 For the Bridgeport

Extra Equipment

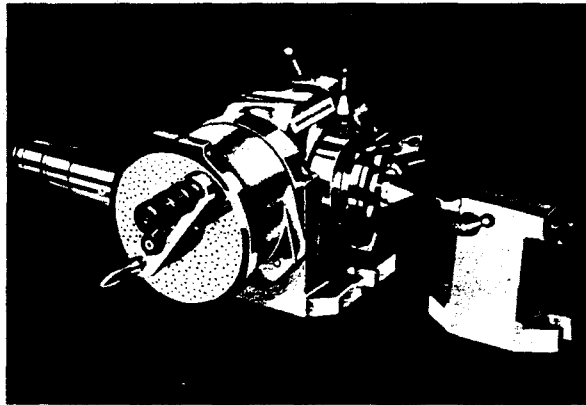

▲ Dividing Heads

▼ Rotary Tables

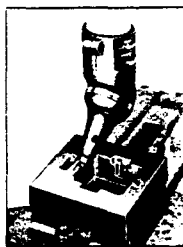
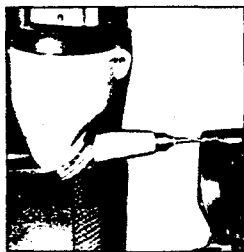
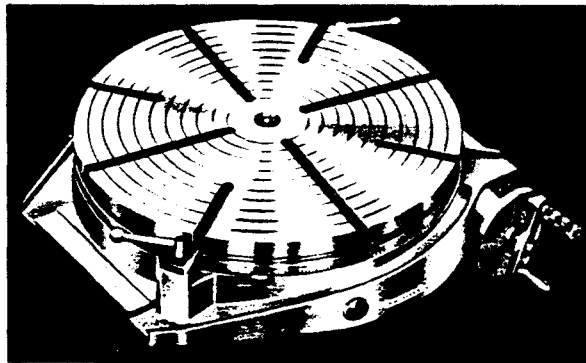

▲ Quillmaster

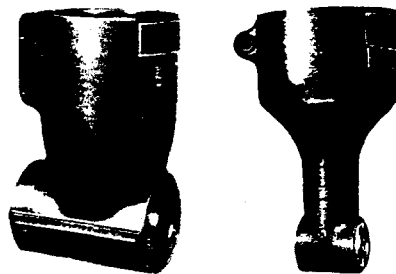

◀ Right Angle Attachment

▼ Equipment Cabinet

▼ Right Angle Arbor Support Bracket

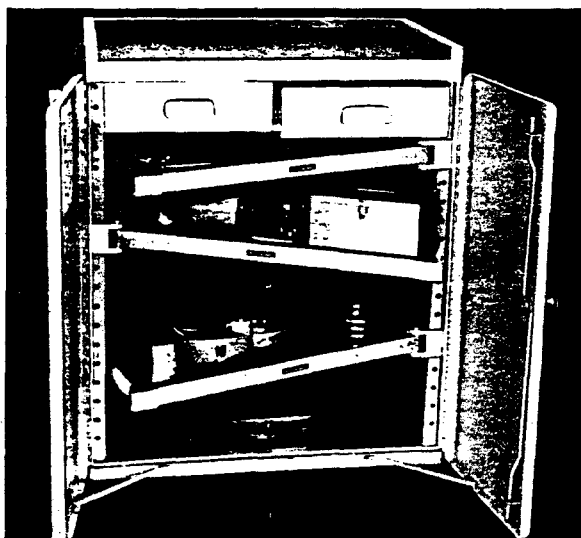
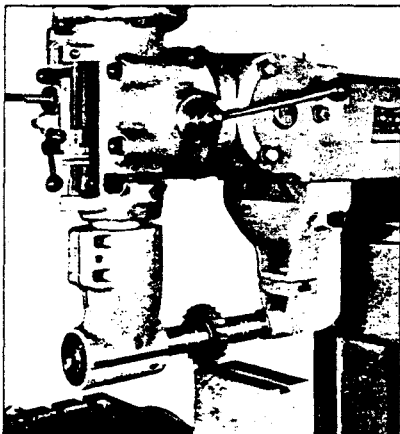

Spare Parts

When ordering replacement parts please quote:-

- THE MACHINE SERIAL No. stamped on the lubrication plate.
- THE HEAD SERIAL No. found on the front of the Belt Housing.
- ITEM NUMBER.
- COMPUTER NUMBER.
- PART NUMBER.
- DESCRIPTION.
- QUANTITY.

* PARTS OBTAINABLE IN ENGLISH OR METRIC.

NOTE

Please refer to additional information at the end of this section.

Spare Parts BASIC MACHINE

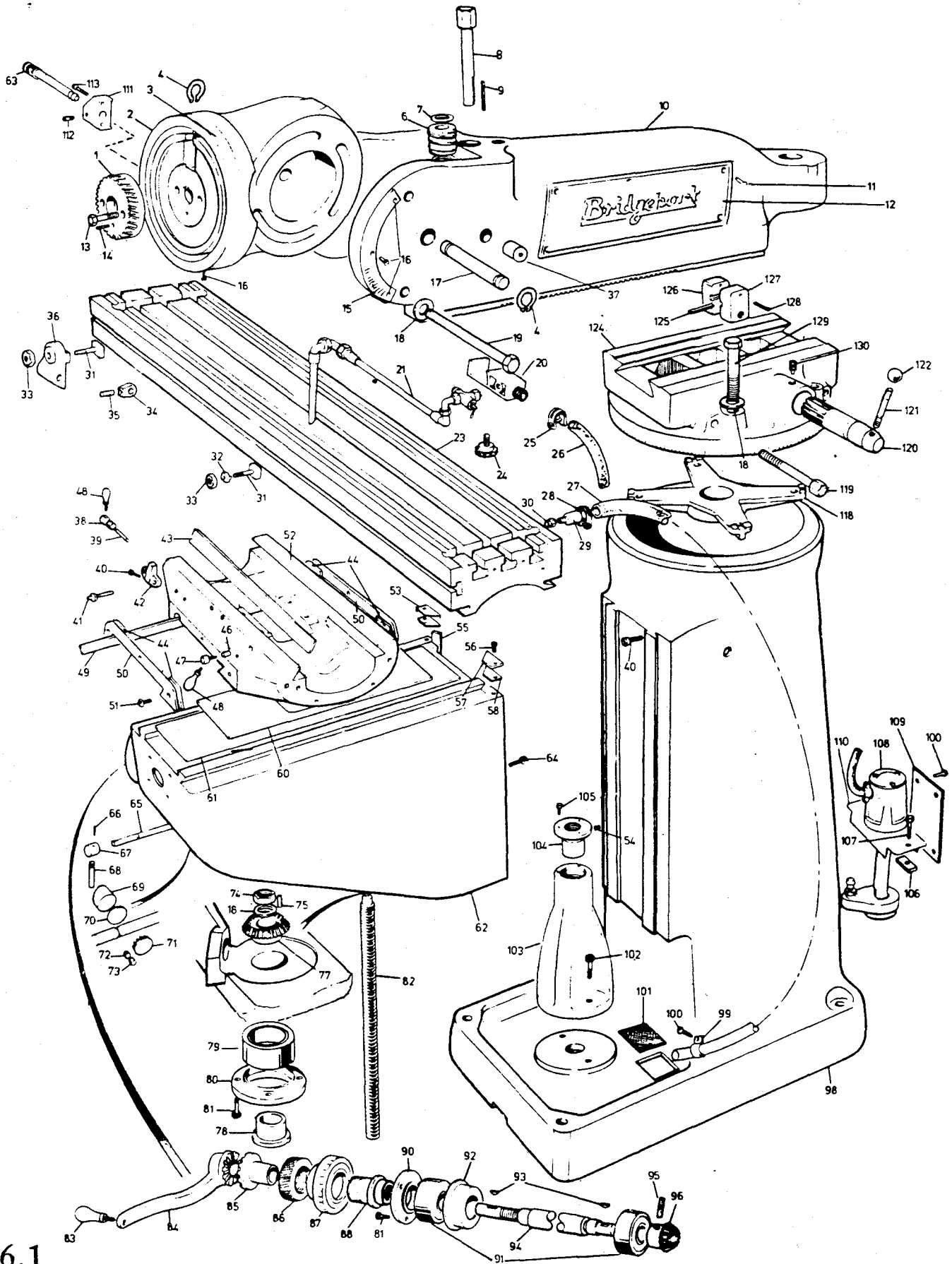

Spare Parts

BASIC MACHINE

ITEM NO	COMP NO	PART NO	DESCRIPTION	QTY
1	8007144	J-144	Quill Housing Adj. Gear	1
2	8005225	H-225	Ram Adaptor	1
3	8007501	J-501	Adaptor Scale	1
4	8300649	ST649	External Circlip	2
6	8005226	H-226	Vertical Adjusting Worm	1
7	8005232	H-232	Worm Thrust Washer	2
8	8005227	H-227	Vertical Adjusting Worm Shaft	1
9	8300091	ST 91	Worm Key 3/16" x 2"	1
10	8005224	H-224	Ram	1
11	8300134	ST 134	Avdel Chebaert Rivets	12
12	8014684	BM 684	Ram Nameplates	2
13	8300627	ST 627	5/16" UNF x 1 1/4" Socket Cap Screw	2
14	8300629	ST 629	3/8" dia. x 1 1/2" lg. Hardened Dowel	1
15	8005236	H-236	Angle Plate	1
16	8300118	ST 118	Round HD. Drive Screws No. 6 x 3/8" long	5
17	8005643	H-643	Adaptor Pivot Pin	1
18	8300379	ST 379	1/2" x 1/8" x 1" Chamfered & Hardened Washer	8
19	8005240	H-240	Adaptor Locking Bolt	3
20	8005501	H-500/1	Tap Bracket (Aluminium)	1
21	8303818	ST 431	LP 398 Suds Tap	1
23	8005114	H-114	Table	1
24	8300406	ST 406	Knob & Screw	1
25	8300389	ST 389	Hose Clip 3/4"	1
26	8300433	ST 433	Plastic Hose 1/2" Bore 42" long	1
27	8300434	ST 434	Plastic Hose 3/4" Bore 44" long	2
28	8300390	ST 390	Hose Clip 1"	2
29	8005507	H-507/A	Gas Adaptor 1/2"	2
30	8300138	ST 138	Plug for 5/8" Coolant Hole	2
31	8005126	H-126	Stop Piece T-Bolt	3
32	8005125	H-125	Table Stop Piece	2
33	8300357	ST 357	3/8" - 16 Hexagon Nut	3
34	8001069	F-69	Stop Collar	2
35	8300219	ST 219	1/4" x 20 x 1/4" S.S.S.	2
36	8001068	F-68	Stop Rod Clamp	1
37	8005700	H-700	Bush	1
38	8005133	H-133	Saddle Lock Bolt	1
39	8005132	H-132	Saddle Lock Plunger	1
40	8300176	ST 176	3/8" - 16 x 1/2" Hollow Head Cap Screw	4
41	8005088	H-88	Strip Adjusting Screw	3
42	8005123	H-123	Table Stop Bracket	1
43	8005119	H-119	Saddle/Table Gib	1
44	8005130	H-130	Felt Wipers	4
46	8005120	H-120	Table Lock Plunger	1
47	8005121	H-121	Table Lock Bolt	1
48	8009053	H-122	Table Lock Bolt Handle	2
49	8005131	H-131	Saddle/Knee Gib	1
50	8005129	H-129	Saddle Knee Wiper Plate	2

Items 51 Continued.....

Spare Parts BASIC MACHINE

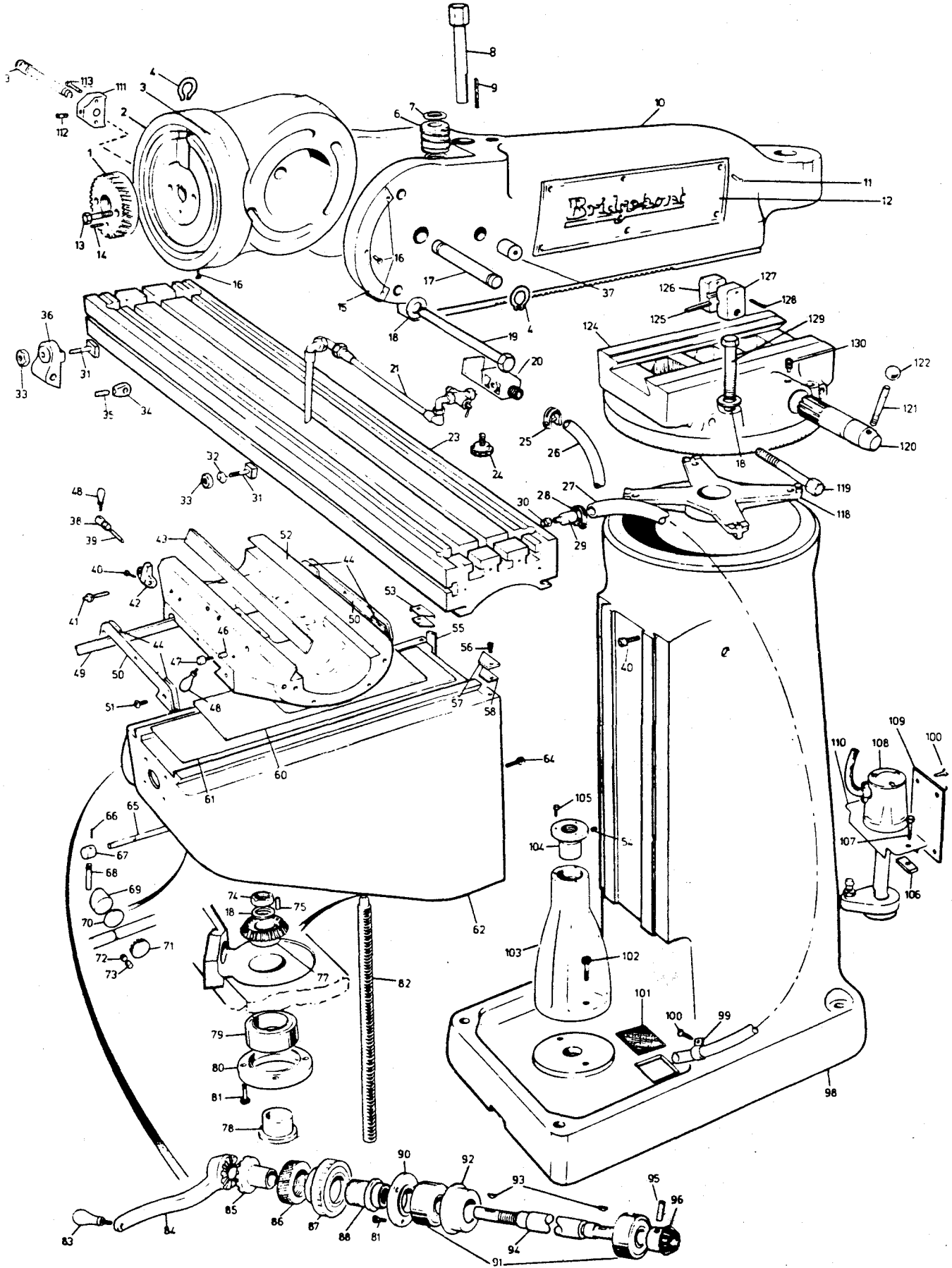

Spare Parts

BASIC MACHINE

ITEM NO	COMP NO	PART NO	DESCRIPTION	QTY
51	8300325	ST325	No.10 - 32 x 1/2" Oval Head Screw	6
52	8005105	H-105	Saddle	1
53	8036056	DR56	Left Hand Column Wiper Holder (for use on DRO only)	1
54	8300135	ST135	1/8" BSP x 3/8" Long Taper Socket Screw	1
55	8005264	H-264	Knee/Column Gib	1
56	8300318	ST318	1/4" UNC x 1/2" Csk. Head Screw	2
57	8036055	DR55	Right Hand Column Wiper Holder (for use on DRO only)	1
58	8005099	H-99	Knee Wiper Felt	2
60	8005268	H-268	Chip Guards	1 pr
61	8005269	H-269	Chip Guards	
62	8005263	H-263	Knee 12"	1
63	8005179	H-179	Head Rotation Stop Pin	1
65	8005266	H-266	Knee Lock Shaft	1
66	8300001	ST1	No. 1 x 1" Taper Pin	1
67	8005093	H-93	Lock Shaft Boss	1
68	8005094	H-94	Lock Shaft Handle	1
69	8005089	H-89	Knee Lock Plunger	1
70	8005538	H-538	Washer Distance/Spacer	1
71	8005146	H-146	Knee Binder Plug (Plastic)	1
72	8300229	ST229	5/16" - 18 x 5/16" Dog Pt. Set Screw	1
73	8300228	ST228	5/16" - 18 x 5/16" Set Screw	1
74	8300349	ST349	1/2" - 20 Jam Nut	1
75	8300086	ST86	3/16" x 3/16" x 7/8" Key	1
77	8005059	H-59	Bevel Gear	1
78	8005055	H-55	Bearing Bush	1
79	8302014	H-52	No. 3606 Grease Sealed Ball Bearing	1
80	8005053	H-53	Bearing Retainer Ring	1
81	8300158	ST158	1/4" x 20 x 1/2" Hollow Head Cap Screw	6
82*	8005051	H-51	Elevating Screw - Imperial (Metric - 8005601)	1
83	8005028	H-28	Handle	1
84	8014682	H-71	Elevating Crank	1
85	8005070	H-70	Gearshaft Clutch Insert	1
86	8005069	H-69	Dial Locknut	1
87	8005067	H-67	Dial with 100 Graduations - Imperial (Metric - 8005604)	1
88	8005068	H-68	Dial Holder	1
90	8005065	H-65	Bearing Retaining Ring	1
91	8302015	H-62	No. 77020 Grease Sealing Bearing	2
92	8005064	H-64	Bearing Cap	1
93	8300068	ST68	No.7 Woodruff Key	2
94	8005265	H-265	Elevating Shaft for 12" Knee	1
95	8300219	ST219	1/4" - 20 x 1/4" Long Set Screw	1
96	8005060	H-60	Bevel Pinion	1
98	8005271	H-271	Column	1
99	8300114	ST114	Clip N5	2
100	8300119	ST119	10 - 24 x 5/8" Self Tap Screw	7

Items 101 continued

Spare Parts BASIC MACHINE

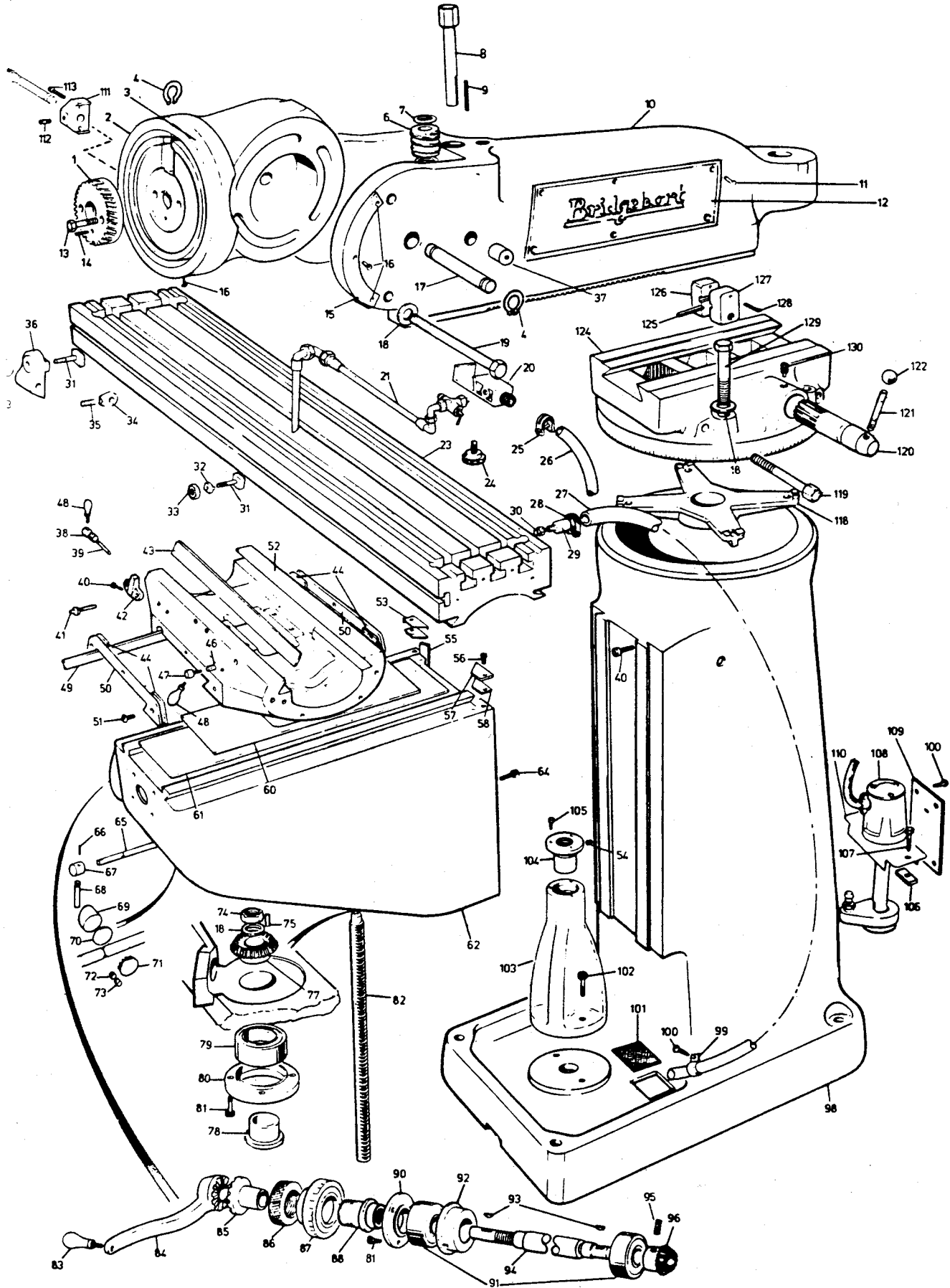

Spare Parts

BASIC MACHINE

ITEM NO	COMP NO	PART NO	DESCRIPTION	QTY
101	8005545	H-545	Strainer	2
102	8300177	ST177	3/8" - 16 x 1" Hollow Head Cap Screw	2
103	8005002	H-2	Elevating Screw Housing	1
104*	8005003	H-3	Elevating Screw Nut - Imperial (Metric - 8005600)	1
105	8300160	ST160	1/4" - 20 x 3/4" Hollow Head Cap Screw	3
106	8005551	H-551	Clamp Bar	2
107	8300161	ST161	Socket Cap Screw 1/4" UNC x 1"	2
108	7008001	AQ3	MG Electric Coolant Pump Motor No. A030	1
109	8005544	H-544	Column Cover	1
110	8500590	ES590	Coolant Pump Mounting Plate	1
111	8005180	H-180	Stop Block (Head Rotation)	1
112	8026040	PF40	Spring Plunger	1
113	8300147	ST147	10 - 24 UNC x 1/2" Long Cap Screw	2
118	8005256	H-256	Spider	1
119	8005230	H-230	Ram Lock Stud	2
120	8005231	H-231	Ram Pinion	1
121	8005237	H-237	Ram Pinion Handle	1
122	8300410	ST410	3/8" x 16 Ball 1 1/4" x 3/8" UNC	1
124	8005254	H-254	Turret	1
125	8005234	H-234	Ram Clamp Bar	2
126	8005239	H-239	Ram Clamp - Blank	2
127	8005233	H-233	Ram Clamp - Screwed	2
128	8300109	ST109	Split Pin 3/8" x 2 1/2"	2
129	8005270	H-270	Locking Pin	4
130	8005238	H-238	Ram Pinion Screw	1
131	8303801	J-326	1 1/4" Open End & 1 - 1/16" Box End Wrench	1

6.2

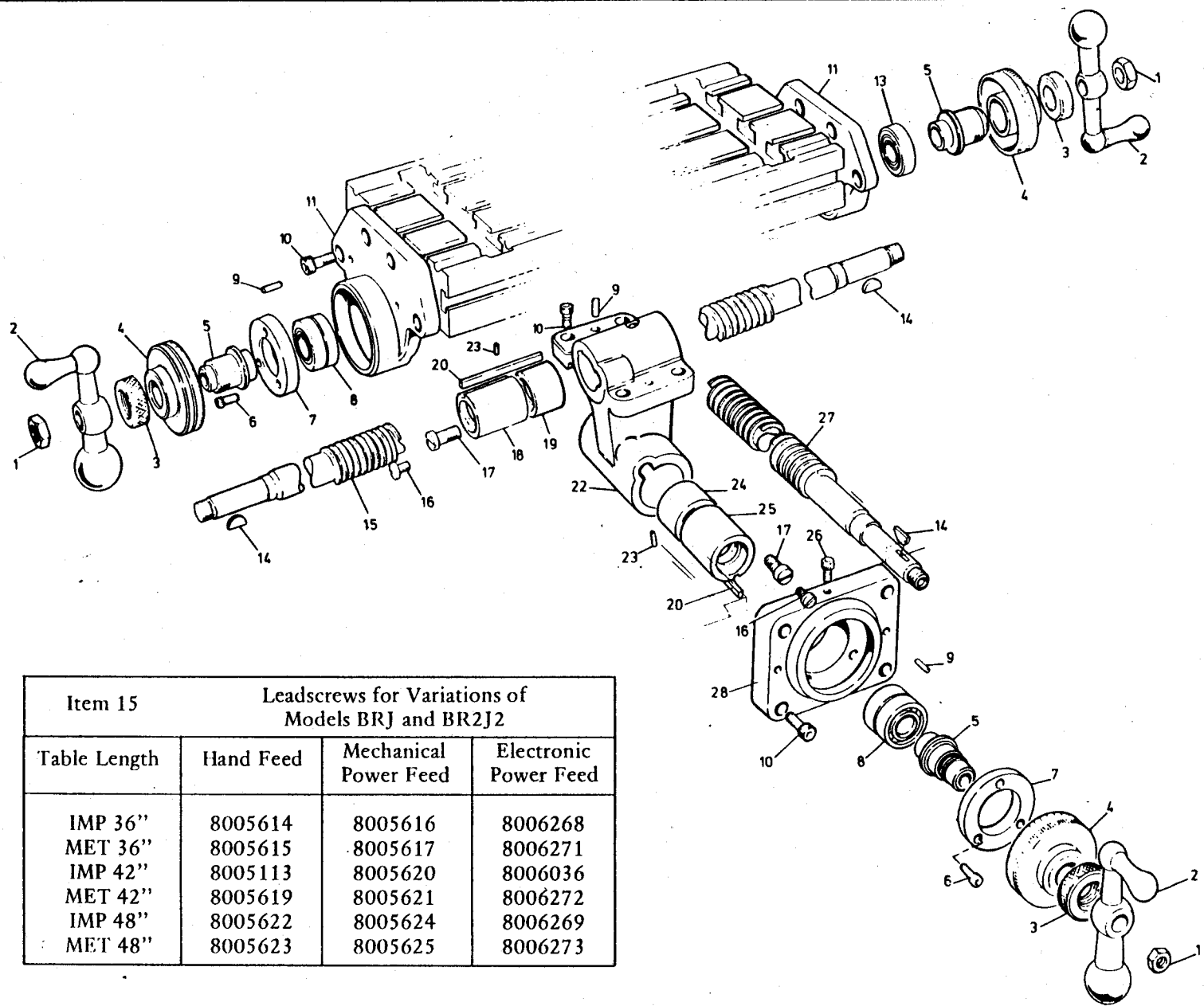

Item 15 Leadscrews for Variations of Models BRJ and BR2J2			
Table Length	Hand Feed	Mechanical Power Feed	Electronic Power Feed
IMP 36"	8005614	8005616	8006268
MET 36"	8005615	8005617	8006271
IMP 42"	8005113	8005620	8006036
MET 42"	8005619	8005621	8006272
IMP 48"	8005622	8005624	8006269
MET 48"	8005623	8005625	8006273

Spare Parts LEADSCREW ASSEMBLY

ITEM NO	COMP NO	PART NO	DESCRIPTION	QTY
1	8300349	ST 349	½" - 20 Jam Nut	3
2	8005080	H-80	Ball Crank Handle	3
3	8005069	H-69	Dial Lock Nut	3
4 *	8005078	H-78	Dial with 200 graduations - Imperial (Metric = 8005605)	3
5	8005079	H-79	Dial Holder	3
6	8300158	ST 158	¼" - 20 x ½" hollow head cap screw	6
7	8005065	H-65	Bearing Retainer Ring	2
8	8302016	H-76	MBU - 011 grease sealed ball bearing	2 PR
9	8300018	ST 18	3/16" x 1" dowel pin	8
10	8300177	ST 177	3/8" - 16 x 1" hollow head cap screw	16
11	8005115	H-115	Bearing brackets	2
13	8302015	H-62	No. 77020 grease sealed ball bearing	1
14	8300068	ST 68	No. 7 Woodruff key	3
15*	See Parts Drawing	H-113	Longitudinal Feed Screw (36", 42", 48") (Plain or Power Feed available in English or Metric)	1
16	8300295	ST 295	No. 8 - 30 x 3/8" washer head screw	2
17	8005108	H-108	Cross Feed Nut Retaining Screw	2
18*	8005112	H-112A	Longitudinal Feed Nut A) supplied as (Metric...8005608A)	1
19*	8005630	H-112B	Longitudinal Feed Nut B) one unit 8005609B)	1
20	8300092	ST 92	3/16" x 3/16" x 2½" key	2
22	8005110	H-110	Feed Nut Bracket	1
23	8005104	H-104	3/32" x ½" steel dowel	2
24*	8005106	H-106A	Cross Feed Nut A) supplied as (Metric 8005606A)	1
25*	8005628	H-106B	Cross Feed Nut B) one unit 8005607B)	1
26	8300498	ST 498	No. 10 - 32 x ¼" stop screw	1
27*	8005267	H-267	Cross Feed Screw for 12" knee - Imperial (Metric - 8005640)	1
28	8005077	H-77	Cross Feed Bearing Bracket	1

Spare Parts J-HEAD TOP HOUSING

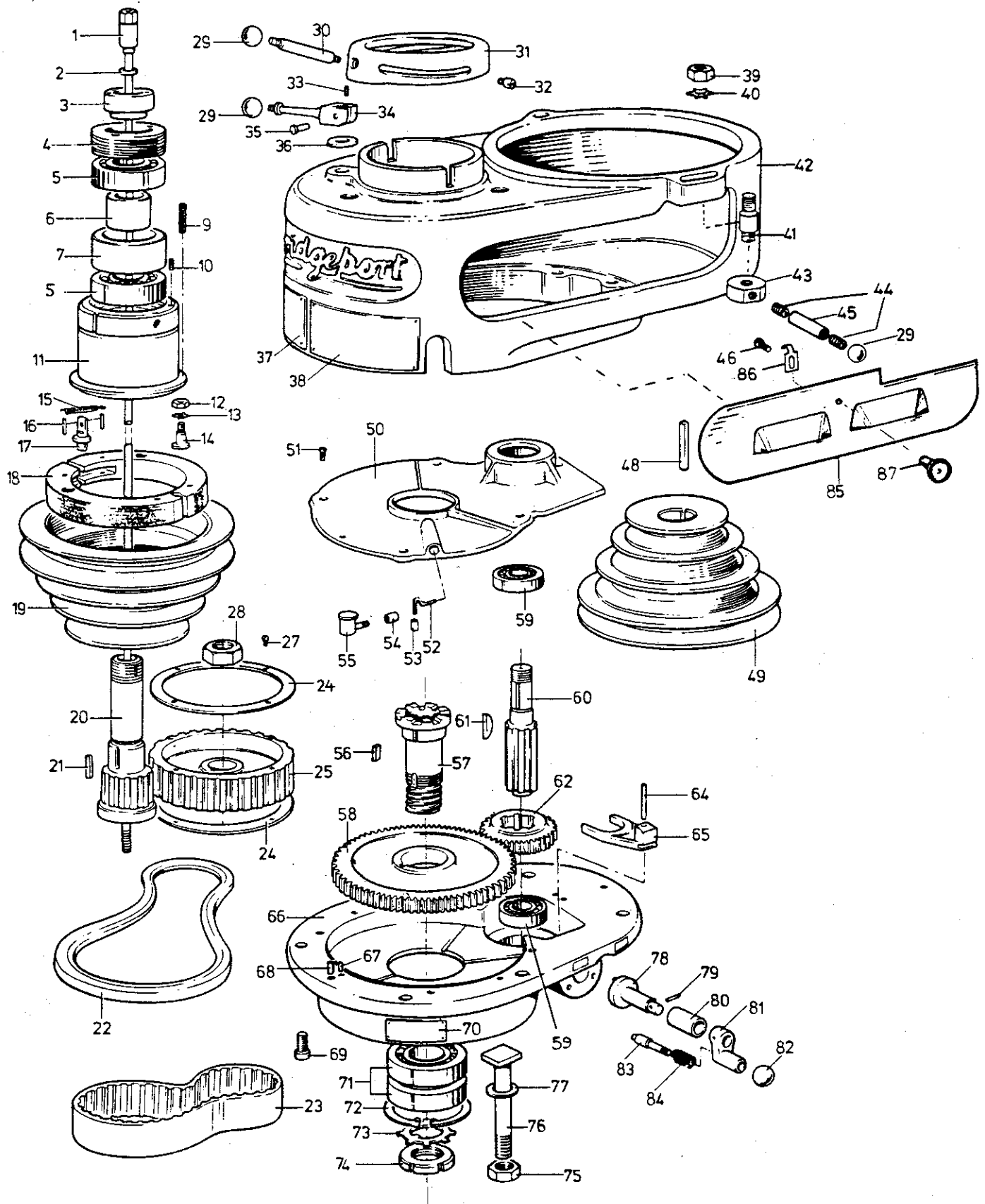

Spare Parts

J-HEAD TOP HOUSING

ITEM NO	COMP NO	PART NO	DESCRIPTION	QTY
1	8007031	J31/2	Drawbar for R.8. Collet	1
2	8007149	J-149	Drawbar Washer	1
3	8007083	J-83	Upper Bearing Locknut	1
4	8007082	J-82	Bearing Sleeve Locknut	1
5	8302018	J-293	M207 KDD - DBJ 773 Bearing	1pr
6	8007081	J-81	Upper Bearing Spacer (small)	1pr
7	8007080	J-80	Upper Bearing Spacer (large)	1pr
9	8300144	ST-144	Compression Spring	4
10	8300200	ST-200	6-32 NC x ¼" KP Socket Set Screw	2
11	8007013	J-13	Spindle Pulley Bearing Sleeve	1
12	8300353	ST353	5/16" 18 Jam Nut	3
13	8300375	ST375	5/16" External Lock Washer	3
14	8007088	J-88	Brake Ring Screw	3
15	8300141	ST141	WB Jones No. 167 - External Spring	2
16	830005	ST5	3/32" x 5/8" Long Roll Pin	4
17	8007089	J-89	Brake Lock Stud	1
18	8007087	J-87	Brake Block	1pr
19	8007005	J-5	Spindle Pulley	1
20	8007075	J-75	Spindle Pulley Hub	1
21	8300096	ST96	Spindle Pulley Key	1
22	8300398	ST398	'V' Belt - Gilmer 4LS 345	1
23	8303792	J-329	Timing Belt 1-1¼" wide	1
24	8007008	J-8	Timing Belt Pulley Flange	2
25	8007007	J-7	Timing Belt Pulley	1
27	8300308	ST308	Flat Head Screw No. 6-32 x 3/8" long	8
28	8300362	ST362	5/8" - 18 Hex. Jam Nut	1
29	8300408	ST408	Black Plastic Ball 1" dia.	4
30	8007085	J-85	Spindle Clutch Lever	1
31	8007084	J-84	Cam Ring	1
32	8007086	J-86	Spindle Clutch Cam Ring Pin	2
33	8300213	ST213	10 - 32 x ¼" long Socket Set Screw	1
34	8007092	J-92	Brake Lock Handle	1
35	8007093	J-93	Brake Lock Pin	1
36	8007091	J-91	Brake Lock Washer	1
37	8007341	J339/B	Spindle Speed Plate	1
38	8007340	J-340	Operating Instruction Plate	1
39	8300341	ST341	3/8" - 24 Hex Jam Nut	2
40	8300373	ST373	3/8" Lock Washer	2
41	8007133	J-133	Motor Mounting Studs	2
42	8007004	J-4	Belt Housing	1
43	8007131	J-131	Motor Locknut	2
44	8300223	ST223	¼" UNC x ¾" Socket Set Screw	4
45	8007132	J-132	Motor Locknut Handle	2
47	8300228	ST228	Socket Set Screw 5/16" - 18 x 5/16" long KP	1
48	8300570	ST570	Key 3/16" x 3/16" x 1¼" Sq. Ends.	1
49	8007006	J-6	Motor Pulley	1
50	8007003	J-3	Gear Housing Cover	

Items 51 continued

Spare Parts J-HEAD TOP HOUSING

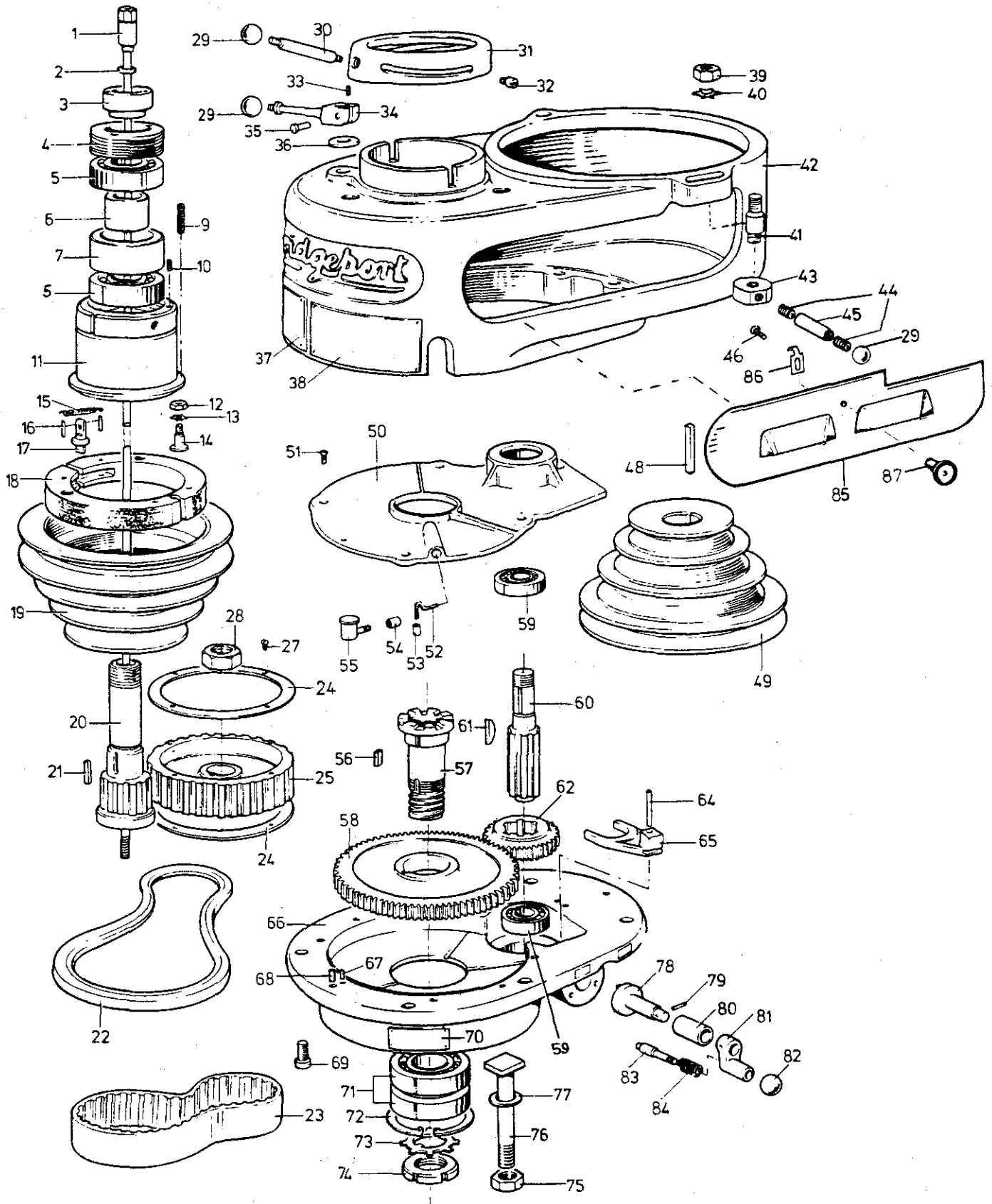

Spare Parts J-HEAD TOP HOUSING

ITEM NO	COMP NO	PART NO	DESCRIPTION	QTY
51	8300262	ST262	Round head Screw No.10-24 x 3/8" long	5
52	8300395	ST395	Wick - 1/8" O.D.	1
53	8007077	J-77	Oiler Tube	1
54	8007078	J-78	Oiler Plug	1
55	8300122	ST122	Gits Oil Cup No.1207	1
56	8300009	ST99	Bull Gear Key	1
57	8007072	J-72	Splined - Gear Key	1
58	8007074	J-74	Spindle Bull Gear	1
59	8302019	J-301	6203 - 2 RS Double Seal Bearing	1pr
60	8007095	J-95	Countershaft	1
61	8300065	ST65	No.9 Woodruff Key	1
62	8007096	J-96	Countershaft Gear	1
64	8300060	ST60	5/16" x 2" long Dowel Key	1
65	8007012	J-12	Back Gear Shifter Fork	1
66	8007002	J-2	Gear Housing	1
67	8300017	ST17	Dowel Pin 3/16" x 1/2" long	2
68	8300024	ST24	1/4" x 1/4" Roller Pins	2
69	8300165	ST165	5/16" - 18 x 5/8" long Socket Cap Screw	6
70	8007354	J-354	Disengage Feed Instruction Plate	1
71	8302017	J-292	M208 K - DB/J732 Bearing	1pr
72	8300103	ST103	No.5000 - 315 Snap Ring	1
73	8007291	J-291	W-08 Lockwasher	1
74	8007290	J-290	N-08 Special 5/16" Thick Bearing Locknut	1
75	8300347	ST347	7/16" - 14 Hex. Nut Hardened	3
76	8007070	J-70	Vertical Tee Bolt	3
77	8007071	J-71	Vertical Tee Washer	3
78	8007153	J-153	Back Gear Shift Crank	1
79	8300013	ST13	1/8" x 7/8" long Roll Pin	1
80	8007152	J-152	Back Gear Shift Bushing	1
81	8007014	J-14	Shift Crank	1
82	8300408	ST408	Black Plastic Ball 1" Dia.	1
83	8007097	J-97	Gearshift Plunger	1
84	8300140	ST140	Compression Spring	1
85	8014601	BM601	Belt Guard for J Head	1pr
86	8014231	BM231	Large Clip	1pr
87	8014234	BM234	Handle Model No.1069	1pr

(Supplied as Assembly 7234001)

Spare Parts J-HEAD J-1 ASSEMBLY

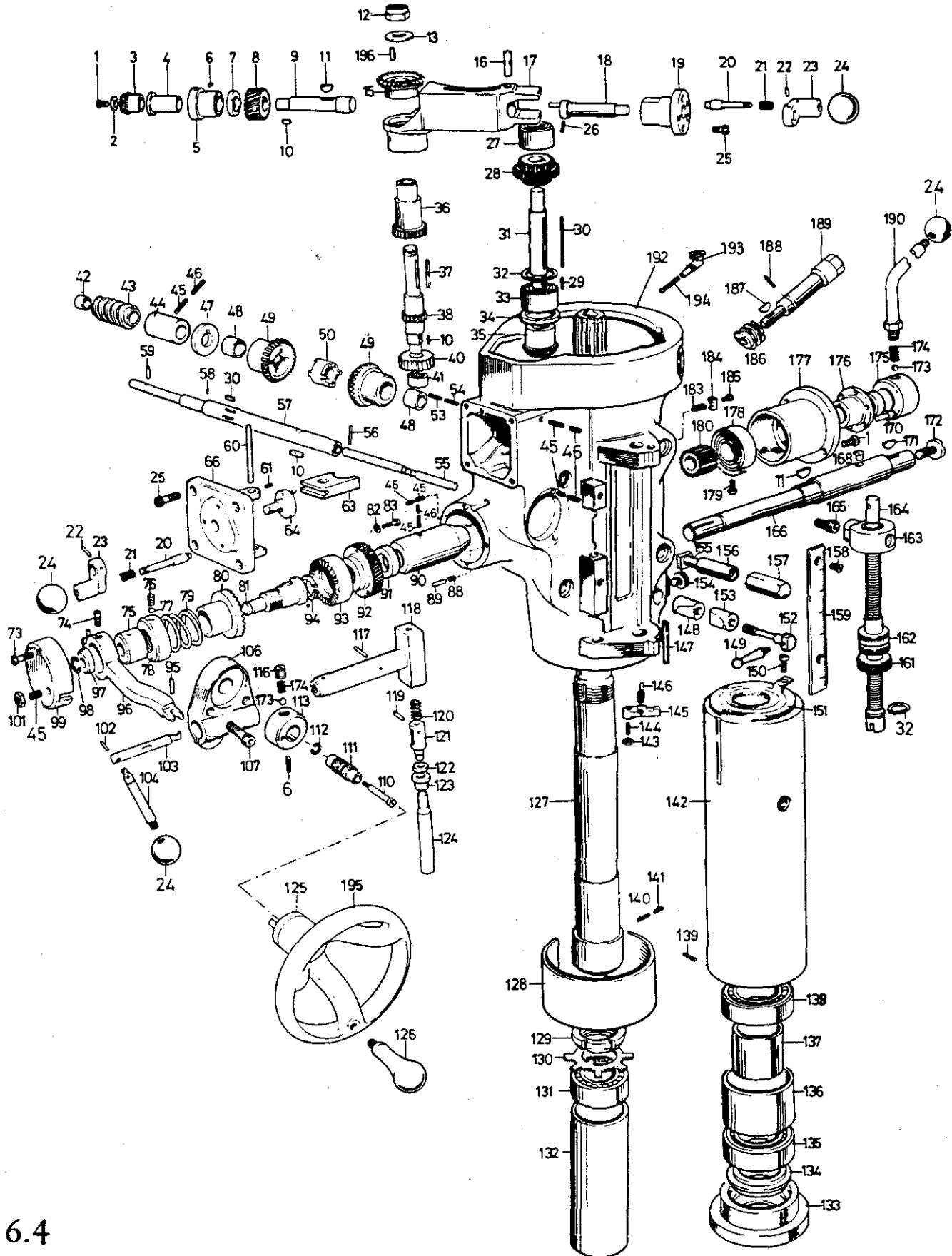

Spare Parts J-HEAD J-1 ASSEMBLY

ITEM NO	COMP NO	PART NO	DESCRIPTION	QTY
1	8300262	ST262	No.10 - 24 x 3/8" Long Rd. Hd. Screw	3
2	8007123	J-123	Bevel Pinion Washer	1
3	8007327	J-327	Feed Bevel Pinion	1
4	8007124	J-124	Feed Worm Gear Shaft Sleeve	1
5	8007136	J-136	Worm Cradle Bushing	1
6	8300220	ST220	1/4" - 20 x 5/16" Grub Screw	2
7	8007125	J-125	Worm Gear Spacer	1
8	8007126	J-126	Feed Drive Worm Gear	1
9	8007127	J-127	Feed Drive Worm Gear Shaft	1
10	8300074	ST74	1/8" Sq. x 3/8" Round End Key	3
11	8300068	ST68	No.7 Woodruff Key	2
12	8300342	ST342	3/8 - 24 Floploc Stop & Locknut	1
13	8300377	ST377	Washer 3/8"	1
15	8007324	J-324	Feed Reverse Bevel Gear	1
16	8007128	J-128	Feed Engage Pin	1
17	8007009	J-9	Worm Gear Cradle	1
18	8007129	J-129	Worm Gear Cradle Throw-out	1
19	8007130	J-130	Shift Sleeve	1
20	8007097	J-97	Gearshift Plunger	2
21	8300140	ST140	Compression Spring	2
22	8300013	ST13	1/8" x 7/8" Roll Pin	2
23	8007014	J-14	Shift Crank	2
24	8300408	ST408	Black Plastic Ball 1" Dia.	4
25	8300147	ST147	No.10 - 24 x 1/2" Long Cap Screw	7
26	8300209	ST209	No. 10 - 24 x 3/8" K.P. Grub Screw	1
27	8007147	J-147	Cluster Gear Shaft Upper Bearing	1
28	8007099	J-99-101	Cluster Gears Assembly (supplied as one unit)	1 Unit
29	8300576	ST576	1/8" Sq. x 1 1/4" Round End Key	1
30	830075	ST75	1/8" Sq. x 9/16" Round End Key	2
31	8007106	J-106	Cluster Gear Shaft	1
32	8300106	ST106	External Circlip 5100-62	2
33	8007108	J-108	Bevel Gear Bearing	1
34	8007109	J-109	Bevel Gear Thrust Spacer	1
35	8007146	J-146	Feed Reverse Bevel Pinion	1
36	8007105	J-105	Feed Driving Gear	1
37	8300077	ST77	1/8" Sq. x 3/4" Round End Key	1
38	8007104	J-104	Cluster Gear Input Shaft	1
40	8007103	J-103	Feed Drive Gear	1
41	8302020	J303	B-66 Torrington Needle Bearing	1
42	8007353	J-353	Bushing	1
43	8007307	J-307	Boston Worm No.HLVH	1
44	8007114	J-114	Feed Worm Shaft Bushing	1
45	8300222	ST222	1/4" - 20 x 1/2" Long Socket Set Screw	6
46	8300225	ST225	1/4" - 20 Mock It Lockscrew	5
47	8007111	J-111	Feed Worm Shaft Thrust Washer	1
48	8007305	J-305	Oilite Bearing Inc. in Bevel Gear J110	2
49	8007110	J-110	Feed Reverse Bevel Gear	2
50	8007112	J-112	Feed Reverse Clutch	1

Items 53 continued

pare Parts J-HEAD J-1 ASSEMBLY

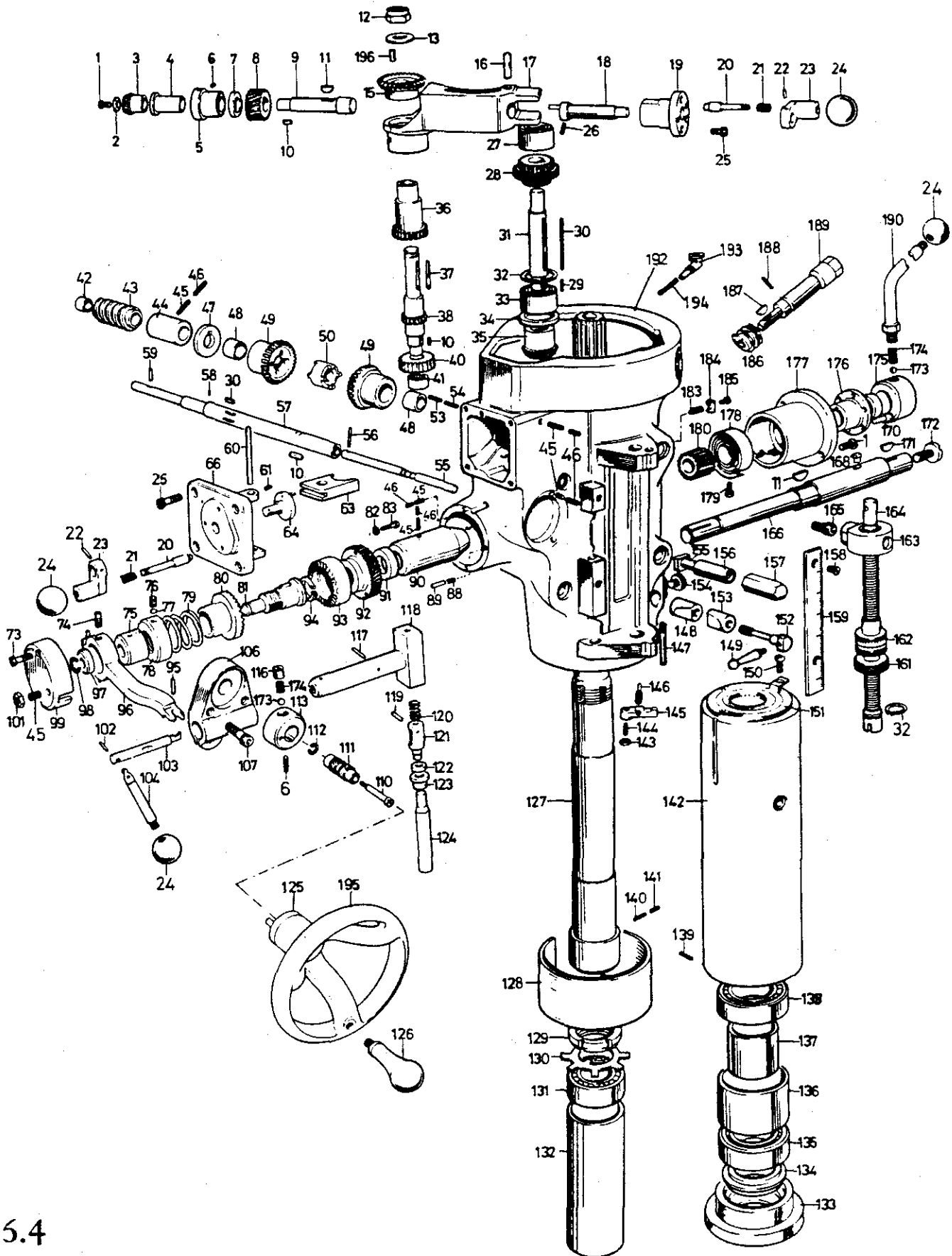

Spare Parts J-HEAD J-1 ASSEMBLY

ITEM NO	COMP NO	PART NO	DESCRIPTION	QTY
53	8300226	ST226	Special Hollow Set Screw 5/16" Chem. bl.	1
54	8300229	ST229	5/16" UNC x 5/16" Dog Point Grub Screw	1
55	8007116	J-116	Reverse Clutch Rod	1
56	8300006	ST6	3/32" x 1/4" Long Roll Pin	1
57	8007188	J-188	Feed Worm Shaft	1
58	8300031	ST31	3/32" x 5/16" Long Pin	1
59	8007308	J-308	110 x 7/16" Long Pin	1
60	8007145	J-145	Feed Shift Rod	1
61	8300213	ST213	10 - 32 x 1/4" Long KP Grub Screw	1
63	8007011	J-11	Feed Gear Shift Fork	1
64	8007098	J-98	Cluster Gear Shift Crank	1
66	8007015	J-15	Cluster Gear Cover	1
73	8300150	ST150	10 - 24 x 1 1/2" Cap Screw	2
74	8007154	J-154	Clutch Ring Pin	2
75	8007053	J-53	Clutch Ring	1
76	8300219	ST219	1/4" UNC x 1/4" Grub Screw	1
77	8300525	ST525	Brass Plug 3/16" Dia. x 3/32"	1
78	8001061	F-61	Overload Clutch Locknut	1
79	8300146	ST146	Safety Clutch Spring	1
80	8007058	J-58	Overload Clutch	1
81	8007054	J-54	Overload Clutch Sleeve	1
82	8300374	ST374	Single Spring Washer	3
83	8300256	ST256	8 - 32 x 5/8" Round Head Screw	3
88	8300144	ST144	Compression Spring 1/4" Dia. x 1 1/4"	1
89	8007051	J-51	Overload Clutch Lever Spring Plunger	1
90	8007062	J-62	Quill Pinion Shaft Bushing	1
91	8007061	J-61	Pinion Shaft Worm Gear Spacer	1
92	8007060	J-60	Overload Clutch Worm Gear	1
93	8007059	J-59	Overload Clutch Ring	1
94	8300105	ST105	External Circlip 5108-59	1
95	8300044	ST44	3/16" x 5/8" Dowel Pin	1
96	8007010	J-10	Overload Clutch Trip Lever	1
97	8007052	J-52	Overload Clutch Washer	1
98	8300101	ST101	External Circlip 5100-37	1
99	8007018	J-18	Clutch Arm Cover	1

Items 101 continued

pare Parts J-HEAD J-1 ASSEMBLY

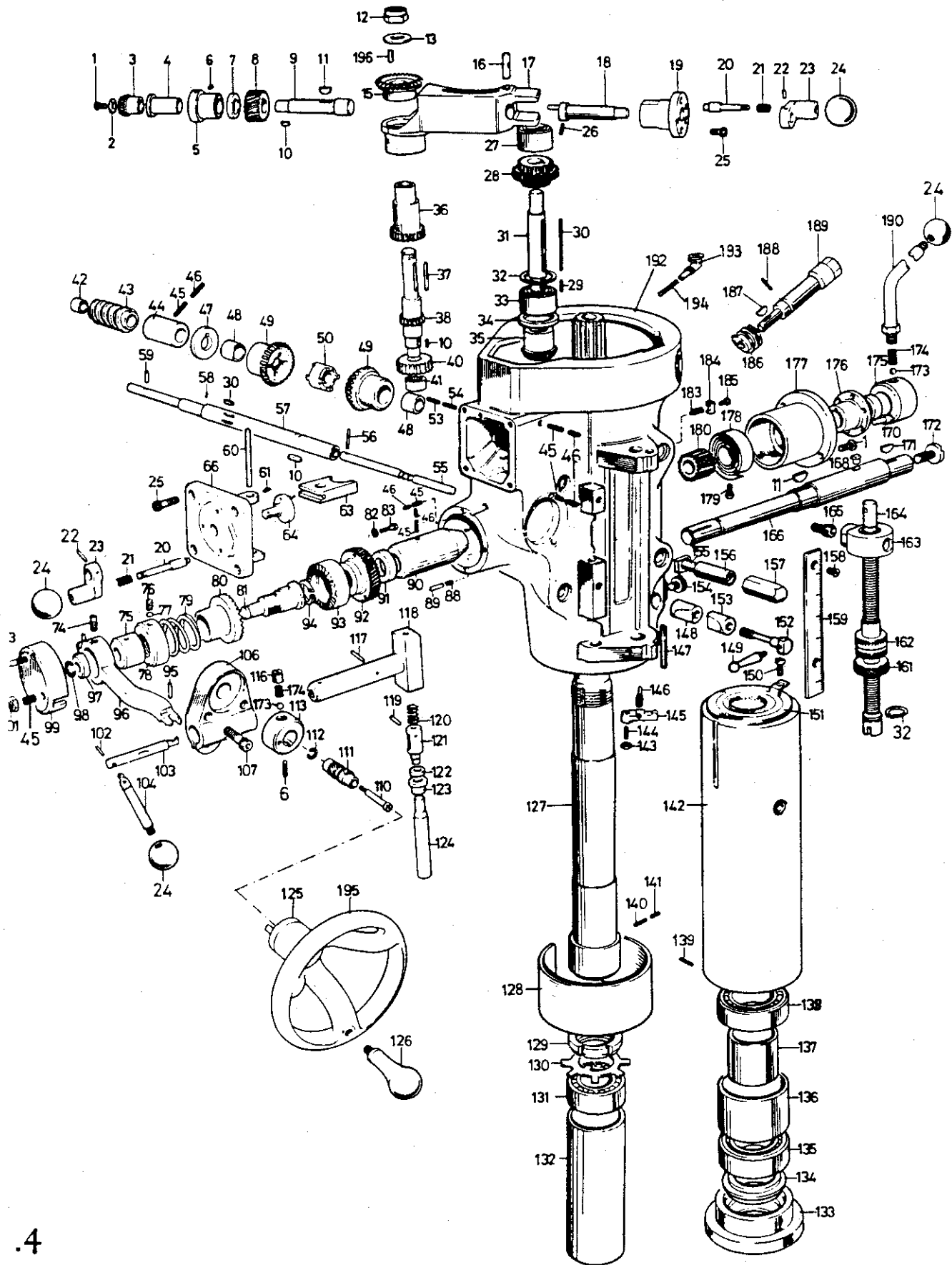

Spare Parts

J-HEAD J-1 ASSEMBLY

ITEM NO	COMP NO	PART NO	DESCRIPTION	QTY	
101	8300352	ST52	Chem. Blacked Locknut ¼ x 20 UNC	1	
102	8300045	ST45	3/16" x ¾" Dowel Pin	1	
103	8007048	J-48	Cam Rod	1	
104	8007049	J-49	Tryg Handle	1	
106	8007017	J-17	Feed Trip Bracket	1	
107	8300161	ST161	¼" - 20 x 1" Long Cap Screw	2	
110	8007156	J-156	Feed Reverse Knob Stud	1	
111	8007117	J-117	Reverse Knob	} (Supplied as Assembly - 7000117)	
112	8300102	ST102	External Circlip 5100-25		1
113	8007118	J-118	Handwheel Clutch		1
116	8007113	J-113	Handwheel Clutch Spring Screw	1	
117	8300011	ST11	1/8" x 9/16" Long Roll Pin	1	
118	8007047	J-47	Cam Rod Sleeve Assembly	1	
119	8300009	ST9	1/8" x 7/16" Long Roll Pin	1	
120	8300139	ST139	Compression Spring	1	
121	8007045	J-45	Trip Plunger	1	
122	8007046	J-46	Feed Trip Plunger Bushing	1	
123	8007044	J-44	Trip Plunger Bushing	1	
124	8007043	J-43	Feed Trip Plunger	1	
125		J-119	Handwheel Insert. inc. with J120	} (Supplied as Assembly - 7000120)	
126	8009043	M-43	Handwheel Handle		1
127	8007166	J-166	Spindle (Serial J-1200 and up-only)	Supplied as Quill Spindle	
128	8007035	J-35	Quill Skirt	Assembly - 7000171)	
129	8007272	J-272	No.06 Locknut	1	
130	8007273	J-273	W-06 Lockwasher	1	
131	8302023	J-349	Fafnir Bearing M206 K 132J30	1	
132	8007176	J-176	Sleeve for Ser J-1750	1	
133	8007172	J-172	Nose-piece	1	
134	8007169	J-169	Spindle Dirt Shield	1	
135	8302022	J-348	Fafnir MM207 LU35T Bearing	1pr	
136	8007170	} J-170	Bearing Spacer Large from J-1750	1pr	
137			J-171		Bearing Spacer Small
138	8302022	J-348	Fafnir MM207 LU35T Bearing		
139	8300219	ST219	¼" UNC x ¼" Grub Screw	1	
140	8007138	J-138'S'	¼" - 32 x 3/4 Collet Alignment Screw	1	
141	8007139	J-139'A'	¼" - 32 x 1/8" Special Locking Grub Screw	1	
142		J-167	Quill (Only Supplied as Quill Spindle Assembly - 7000171)	1	
143	8300336	ST 336	Steel Nut 6-32 NC	1	
144	8300609	ST609	6 - 32 x ¾" Grub Screw	1	
145	8007042	J-42	Feed Trip Lever	1	
146	8007151	J-151	Trip Lever Pin	1	
147	8009052	M-52	Indicator Rod		
148	8007065	J-65	Quill Lock Sleeve Tapped	1	
149	8009047	M-47	Lock Handle	1	
150	8007276	J-276	10-32 x 5/16" Long RD. HD. Screw	2	

Spare Parts

J-HEAD J-1 ASSEMBLY

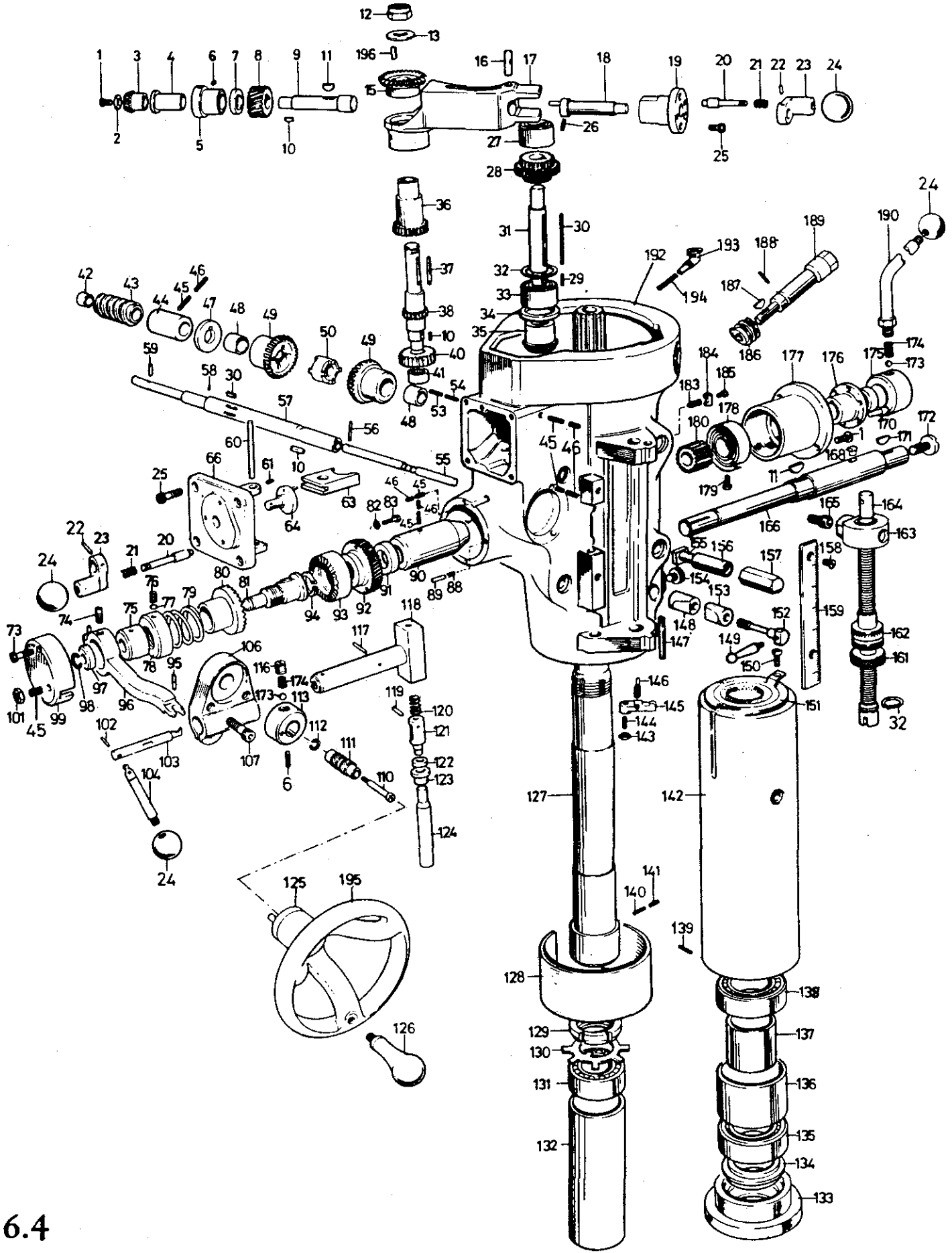

Spare Parts

J-HEAD J-1 ASSEMBLY

ITEM NO	COMP NO	PART NO	DESCRIPTION	QTY
151	8007368	J-368	Oil Strainer for Quill Bearing	1
152	8007067	J-67	Quill Lock Bolt	1
153	8007066	J-66	Drilled Lock Sleeve	1
154	8009051	M-51	Indicator Rod Screw	1
155	8007601	J-601	½" - 6-3/16" Tee Bolt	4
156	8007094	J-94	Lower Clamping Bolt Spacer	2
157	8007603	J-603	½" - 1½" Adaptor Nut	4
158	8300252	ST 252	6 - 32 x ¼" Chem. Blacked Rd. Hd. Screw	2
*159	8007322	J-322	Micrometer Scale - Imperial (Metric 8007624)	1
*161	8007157	J-157	Quill Micro-Stop Nut (included with 8007037)	1
*162	8007038	J-38	Micrometer Nut (Included with 8007037)	1
163	8007036	J-36	Quill Stop Knob	1
*164	8007037	J-37	Quill Stop Micro-Screw - Imperial (Metric - 8007611)	1
165	8300184	ST184	3/8" UNF x 5/8" Cap Screw	1
166	8007063	J-63	Quill Pinion Shaft	1
168	8009089	M-89	Spring Pin	1
170	8300030	ST 30	3/16" x ¼" Long Dowel Pin	1
171	8300066	ST 66	No. 3 Woodruff Key	1
172	8007148	J-148	Pinion Shaft Hub Screw	1
173	8300132	ST 132	3/16" Steel Ball	2
174	8300145	ST145	½" Long Compression Spring	2
175	8009053	M-53	Rack Feed Handle Hub	1
176	8009033	M-33	Pinion Shaft Hub Sleeve	1
177	8007016	J-16	Spring Cover	1
178	8007328	J-328	Clock Spring 1" x .020" x 42"	1
179	8007150	J-150	Outside Clock Spring Pin	1
180	8007064	J-64	Quill Pinion	1
183	8007039	J-39	Reverse Trip Ball Lever	1
184	8007040	J-40	Feed Reverse Trip Plunger	1
185	8007041	J-41	Reverse Trip Ball Lever Screw	1
186	8007140	J-140	Worm Gear	1
187	8300067	ST 67	No. 5 Woodruff Key	1
188	8300227	ST 227	Socket Set Screw ¼" UNC x 20 x ¼"	1
189	8007141	J-141	ADJ Worm Shaft	1
190	8009054	M-54	Pinion Shaft Hub Handle (Supplied with 8009053 Item 175)	1
192	8007001	J-1	Quill Housing	1
193	8303779	J-339	Oil Cup	1
194	8300395	ST 395	Wick	1
195		J120	Handwheel Moulding (Supplied with 1256126 as 7000120)	1
196	8300071	ST71	1/8" Sq. x 5/16" Round End Key	1

Spare Parts 2J2-HEAD TOP HOUSING

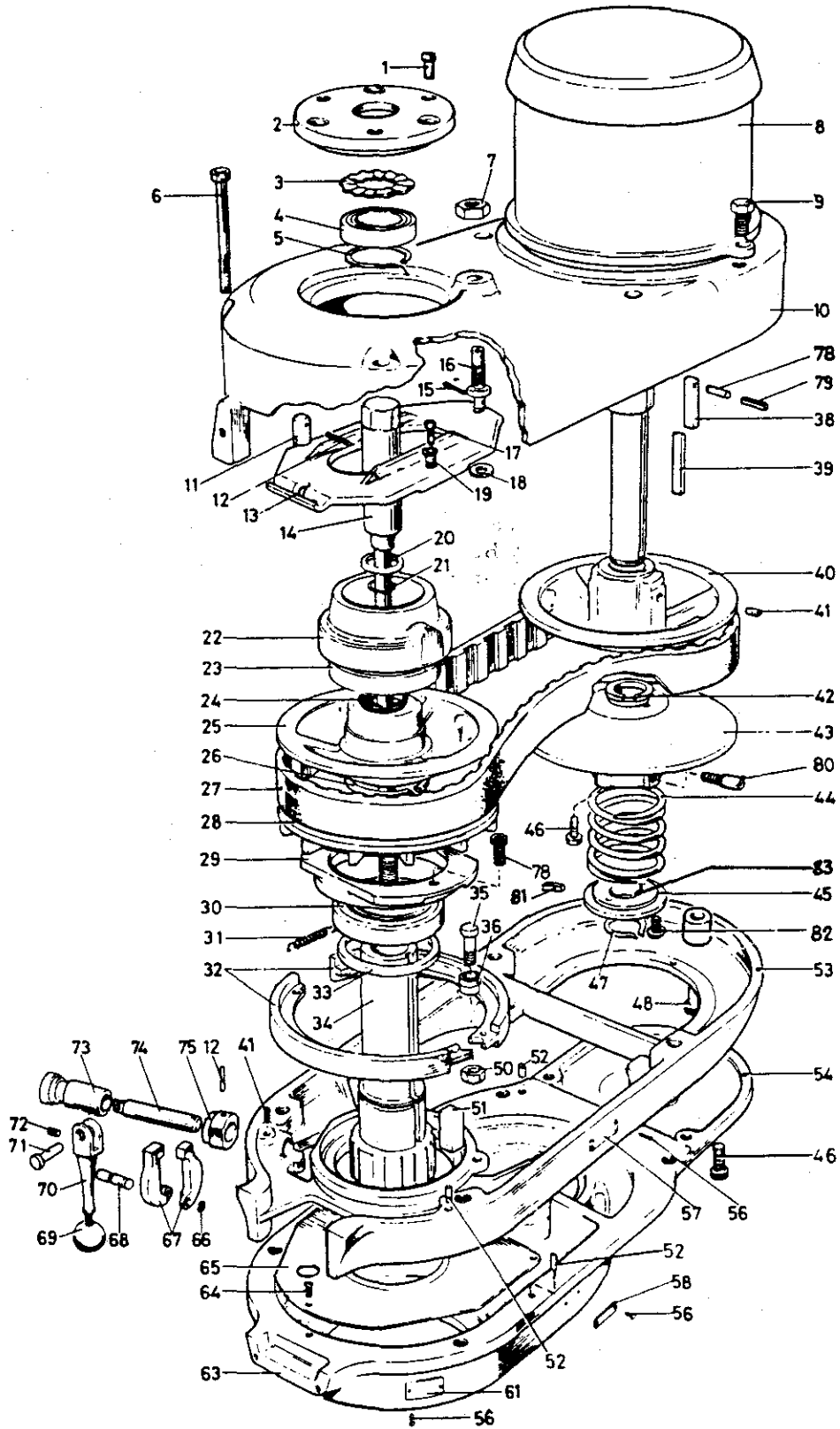

Spare Parts 2J2-HEAD TOP HOUSING

ITEM NO	PART NO	COMP NO	DESCRIPTION	QTY
1	8300160	ST 160	¼" - 20 x ¾" Socket Cap Screw	3
2	8025601	2J-601	Top Bearing Cap	1
3	8025552	2J-552	Wave Spring Washer	1
4	8302037	2J-587	Ball Bearing Fafnir No. RM9107NPP - E9147	1
5	8300124	ST 124	Snap Ring No. 5100 - 137	1
6	8300194	ST 194	5/16" - 18 x 6" Socket HD. Cap Screw	2
7	8300351	ST 351	3/8" - 16 UNC Hex. Jam Nut	1
8	7007606	2J-667	Motor 2HP (complete unit)(1.5 h.p. = 7007603)	1
9	8300460	ST 460	3/8" - 16 x 1" Hex. HD. Screws	2
10	8025500	2J-500	Belt Housing (Supplied with Item 53 as Pair)	1
11	8025515	2J-515	Speed Change Chain Stud	1
12	8300022	ST 22	5/32" Dia. x 7/8" Long Roll Pin	2
13*	8025507	2J-507	Speed Change Plate	1
14	8025543	2J-543	Drawbar	1
15	8300005	ST 5	3/32" Dia. x 5/8" Cotter Pin	1
16	8025526	2J-526	Speed Change Plate Pivot Stud	1
17	8025566	2J-566	10 - 32 x 5/8" Socket HD. Cap Screw Loc-wel	2
18	8025602	2J-602	Washer for 2J-526	1
19	8025546	2J-546	Pivot Sleeve for 2J-507	2
20	8025600	2J-600	Drawbar Washer	1
21	8025573	2J-573	"O" Ring Parker No. 2-14	1
22	8025505	2J-505	Spindle Pulley Bearing Sliding Housing	1
23	8302038	2J-588	Ball Bearing, Fafnir No. PM9110NPP - E9147	1
24	8025665	2J-665	Plastic Insert (Not Supplied as Separate Item see Item 25)	2
25	7012533	2J-533	Adjustable - Driven Varidisc	1
26	8300123	ST 123	Circlip No. 5102-156	1
27	8303793	2J-668	Belt	1
28	7012534	2J-534	Stationary Drive Varidisc	
29	8025506	2J-506	Brake Bearing Cap	1
30	8302038	2J-038	Ball Bearing Fafnir No. PM9110NPP - E9147	1
31	8025524	2J-524	Brake Spring	2
32	8025525	2J-525	Brake Shoes	2
33	8025530	2J-530	Spindle Pulley Spacer	1
34	8025707	2J-707	Spindle Pulley Hub	1
35	8025578	2J-578	¼" - 20 x ¾" Hex. HD. Screw	1
36	8025522	2J-522	Brake Shoe Pivot Sleeve	1
37				
38	8025647	2J-647	Drive Key	1
39	8025646	2J-646	Key for ADJ. Varidisc Motor Shaft (Only Supplied with	1
40	7012532	2J-532	Stationary Mortor Varidisc	Item 43)
41	8025571	2J-571	¼" - 20 x ¾" Socket Set Screw	2
42	8025648	2J-648	Plastic Insert	2
43	7012642	2J-642	Adjustable Motor Varidisc 2 h.p. (1½ h.p. - 7012531)	1
44	8025661	2J-661	Spring for Varidisc Motor Shaft	Not Supplied as Individual
45	8025644	2J-644	Adjustable Varidisc Spring Collar	Item, only as Item 43 Assembly
46	8300175	ST 175	10 - 24 UNC x 1" Long Socket Cap Head Screw	3
47	8300546	ST546	Ret. Ring No. 5103-93	1
48	8300166	ST 166	5/16" x ¾" Socket Cap Screw	1
49	8025663	2J-663	Plastic Key for 2J-533 (Supplied only as Item 25)	1
50	8300352	ST 352	Chem Blacked Locknut ¼" - 20 UNC	1

Items 51 Continued.....

Spare Parts 2J2-HEAD TOP HOUSING

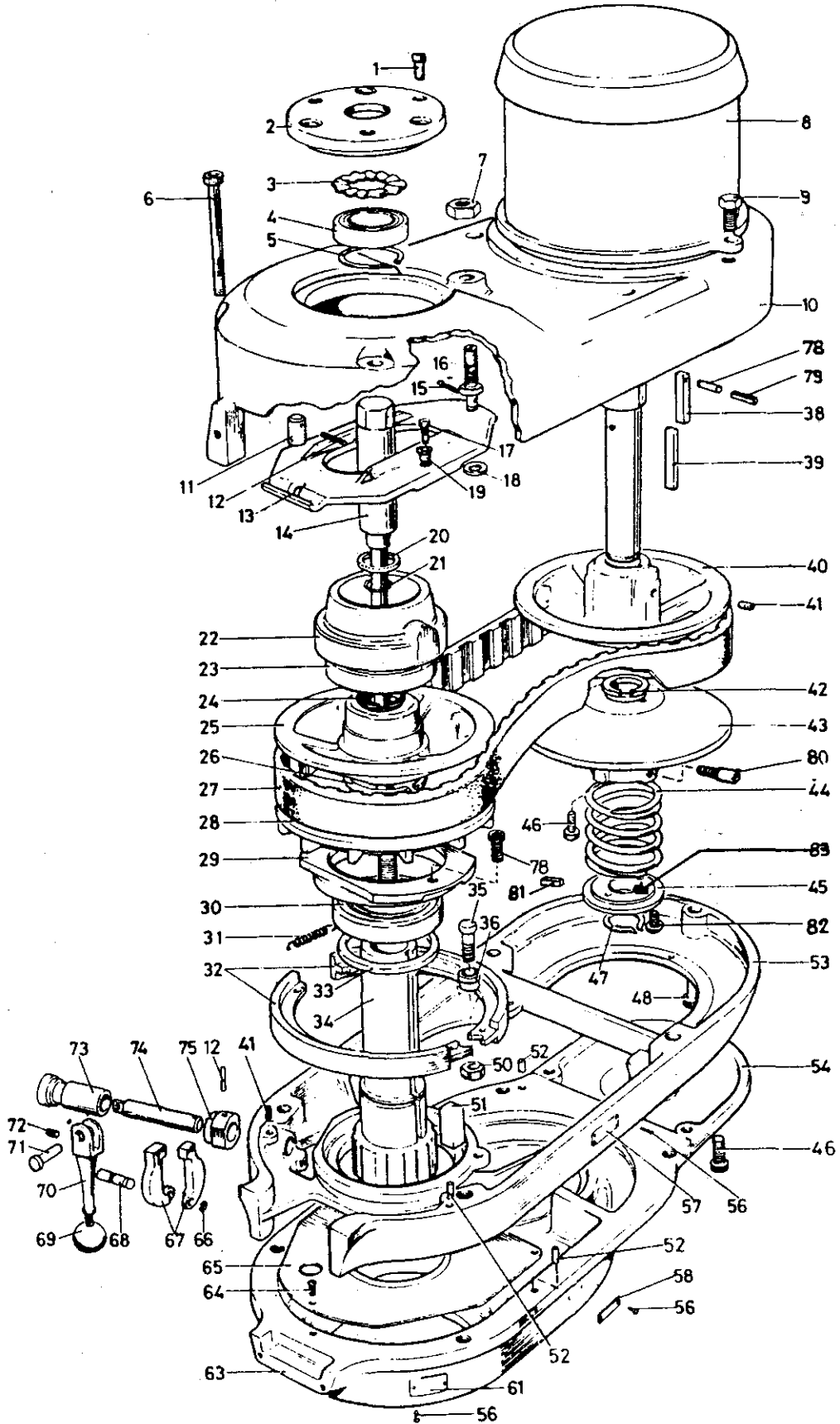

Spare Parts 2J2-HEAD TOP HOUSING

ITEM NO	COMP NO	PART NO	DESCRIPTION	QTY
51	8025536	2J-536	Key for 2J-509 - 2J-534	1
52	8025677	2J-677	Taper Pin No. 4 x 1"	4
53	8025501	2J-501	Belt Housing Base (supplied as one unit part of 2J-500)	1
54	8025545	2J-545	Motor Pulley Cover	1
55				
56	8300131	ST 131	Avdel Choebert Rivets	8
57	8025619	2J-619	Nameplate for Varidrive	1
58	8025654	2J-654	HI-LOW Range Nameplate	1
60				
61	8025655	2J-655	Quill Feed Nameplate	1
63	8025502	2J-502	Gear Housing	1
64	8300262	ST262	No. 10 - 24 x 3/8" Round Hd. Machine Screw	3
65	8025538	2J-538	Gear Housing Plate	1
66	8300102	ST 102	Snap Ring No. 5100-25	1
67	8025523	2J-523	Brake Operating Finger	2
68	8025535	2J-535	Brake Finger Pivot Stud	1
69	8300408	ST 408	1/4" x 20 Bakelite Ball Handle	1
70	8007092	J-92	Brake Lock Handle	
71	8007093	J-93	Brake Lock Pin	
72	8300213	ST 213	10 - 32 x 1/4" Long Socket Set Screw	
73	8025614	2J-614	Sleeve for Brake Lock Shaft 2J-521	1
74	8025521	2J-521	Brake Lock Shaft	1
75	8025519	2J-519	Brake Lock Cam	
77	8025571	2J-571	1/4" - 20 x 3/4" Socket Set Screw	1
78	8300007	ST-7	Roll Dowel	1
79	8300015	ST-15	Roll Dowel Pin	1
80	8300151	ST151	Screw	1
81	8025645	2J-645	Key	1
82	8300616	ST 616	Round HD. Screw	1
83	8025645	2J-645	Key	1

Refer to page 6-4

Spare Parts 2J2 -HEAD BACK GEAR

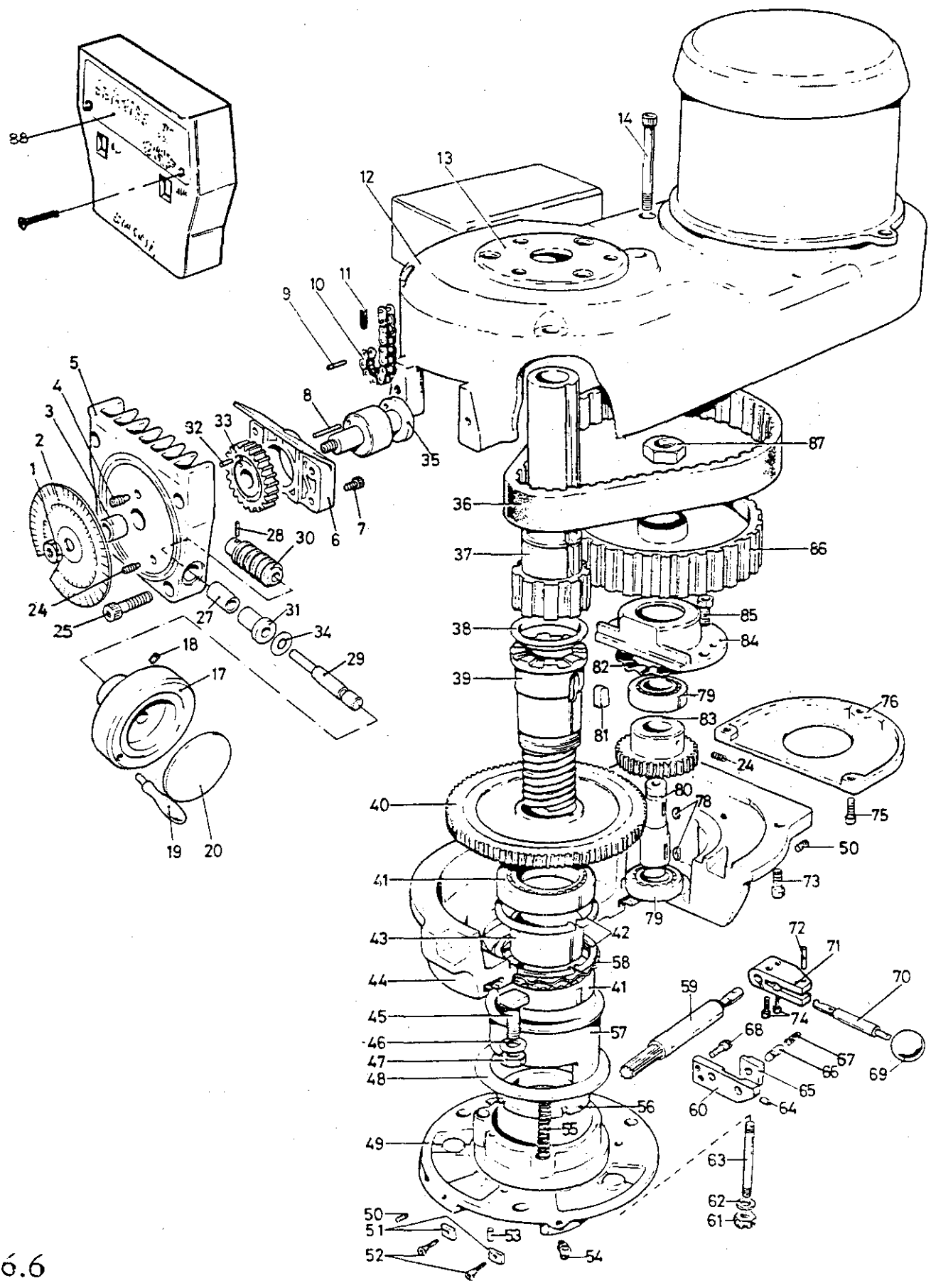

Spare Parts 2J2-HEAD BACK GEAR

ITEM NO	COMP NO	PART NO	DESCRIPTION	QTY
1	8300354	ST354	5/16" Hex. nut	1
2	8014634		50 Hz Dial (8014613 60 50 Hz Dial) 6 Hz)	1
3	8302043	2J-658	Bronze Bearing Boston No. B810-4	1
4	8025585	2J-585	¼" - 20 x ½" Full Dog Socket Set Screw	1
5	8025504	2J-504	Speed Changer Housing	1
6	8025720	2J-720	Plastic Bearing Block	1
7	8300159	ST159	1/4" UNC x 5/8" Socket Head Cap Screw	4
8	8302036	2J-537	Bearing for 2J-504	1
9	8300021	ST21	1/8" Dia. x 1" Long Roll Pin	1
10	8025572	2J-572	Speed Changer Chain	1
11			Split Link supplied with 2J-572	1
12	8025500	2J-500	Belt Housing	1
13	8025601	2J-601	Top Bearing Cap	1
14	8300193	ST193	5/16" - 18 - 4" Socket Head Cap Screw	1
17	8025719	2J-719	Speed Change Hub	1
18	8300221	ST221	1/4" UNC x 3/8" Socket Set Screw	1
19	8025599	2J-599	Machine Handle No. 3302	1
20	8025653	2J-653	Caution Plate	1
24	8025571	2J-571	¼" - 20 x ¼" Socket Set Screw	2
25	8300162	ST162	socket Headed Cap Screw	4
27	8302042	2J-657	Bronze Bearing Boston No, B79-10	1
28	8300619	ST619	2.5 mm Dia. x 12 mm Long Roll Dowel	1
29	8025716	2J-716	Speed Control Shaft	1
30	8007307	J-307	Boston Worm Gear	1
31	8302041	2J-656	Bronze Bearing Boston Bo. B56-5	1
32	8300638	ST638	5/16" Dia. x 3/8" Long Roll Dowel	1
33	8025547	2J-547	Speed Change Spur Gear	1
34	8300637	ST637	3/8" Inside Dia. Wavy Spring Washer	1
35	8025514	2J-514	Speed Change Chain Drum	1
36	8303791	2J-650	Belt - 2 h.p. (1½ h.p. - 8303792)	1
37	8025707	2J-707	Spindle Pulley Hub 2 h.p. (1½ h.p. - 8025509)	1
38	8025513	2J-513	Timing Pulley Clutch Sleeve - (Bought in situ)	1
39	8025508	2J-508	Splined Gear Hub	1
40	8025511	2J-511	Spindle Bull Gear (Must Also Order Item 83 as Matched Pair)	1
41	8302039	2J-039	Ball Bearing Fafnir RM9308NPP-E9147	2
42	8300097	ST97	Snap Ring No.5000-244	2
43	8025512	2J-512	Bull Gear Bearing Spacer	1
44	8025502	2J-502	Gear Housing	1
45	8025541	2J-541	Vert. Tee Bolts	3
46	8300368	ST368	15/32" ID x 15/16" OD x 1/16" Steel Washer	3
47	8300343	ST343	7/16" - 14 Hex. Jam Nut - finished HDN	3
48	8025618	2J-618	Ball Bearing Gear Sleeve Washer	1
49	8025503	2J-503	Fixed Clutch Bracket for J-1	1
50	8300211	ST211	5/16" - 24 x 5/16" Socket Set Screw	2

Items 51 continued

Spare Parts 2J2 -HEAD BACK GEAR

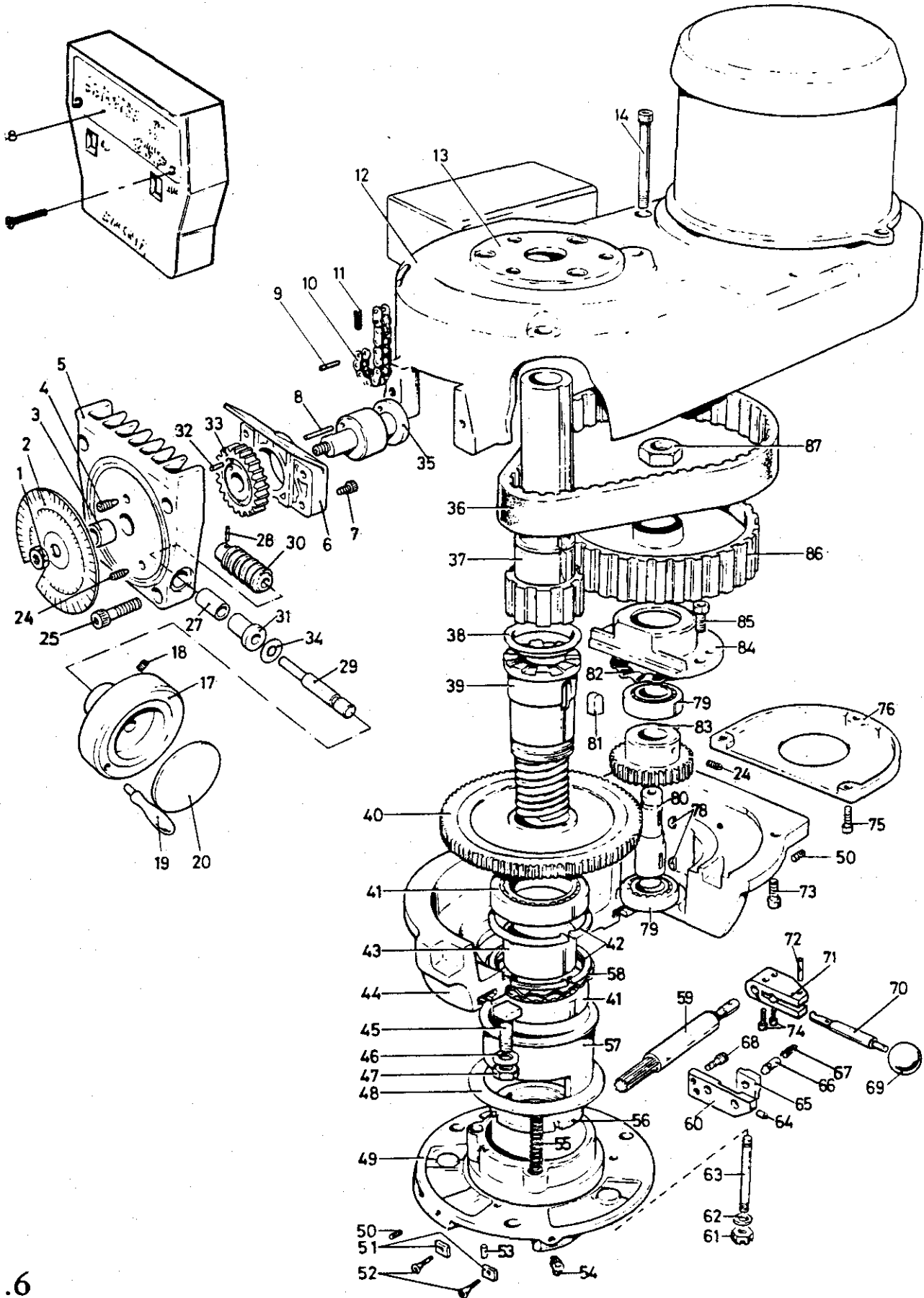

Spare Parts 2J2-HEAD BACK GEAR

ITEM NO	COMP NO	PART NO	DESCRIPTION	QTY
51	8025615	2J-615	Guide for 2J-503, 2J-510	2
52	8025671	2J-671	10-32 x 3/8" Flat HD. Socket Cap Screw	2
53	8300007	ST 7	Roll Dowel 1/8" x 1/4" Long Loc-wel	1
54	8025597	2J-597	Gits Style L No. 1202 Oil Cup	1
55	8025577	2J-577	3/8" OD. x 3" Long Compression Spring	3
56	8025557	2J-557	N-08 Bearing Locknut	1
57	8025510	2J-510	Bearing Sleeve	1
58	8025552	2J-552	Wave Spring Washer	1
59	8025516	2J-516	Bull Gear Shift Pinion	1
60	8025604	2J-604	HI-LOW Detent Plate	1
61	8300581	ST 581	3/8" - 16 Hex. Nut	3
62	8300363	ST 363	3/8" Lock Washer	3
63	8025542	2J-542	Studs for J1 - to 2J-503	3
64	8300214	ST214	10-32 x 3/8" Cup Point	1
65	8025605	2J-605	Adjustable Plate for 2J-604	1
66	8025607	2J-607	HI-LOW Detent Plunger	1
67	8025582	2J-582	Spring 3/4" x .032 x 9/16"	1
68	8300153	ST 153	10-32 x 1/2" Long Socket Cap Screw	2
69	8300408	ST 408	1/4" x 20 Bakelite Ball Handle	1
70	8025606	2J-606	HI-LOW Shift Crank	1
71	8025603	2J-603	HI-LOW Pinion Block	1
72	8300016	ST16	1/8" Dia. x 5/8" Long Roller Pin	1
73	8300166	ST166	5/16" x 3/4" Socket Cap Screw	4
75	8300175	ST175	No.10 - 24 x 1" Socket Hd. Cap Screw	1
76	8025545	2J-545	Motor Pulley Cover	1
78	8300065	ST65	No.9 Woodruff Key	2
79	8302040	2J-590	Ball Bearing Fafnir No. RM203NPP-E9147	2
80	8025527	2J-527	Bull Gear Pinion Counter Shaft	1
81	8025613	2J-613	Key for 2J-508, 2J-511	1
82	8025551	2J-551	Wave Spring Washer	1
83	8025529	2J-529	Bull Gear Pinion	1
84	8025528	2J-528	Bull Gear Pinion Bearing Cap	1
85	8300149	ST149	10 - 24 x 5/8" Socket Hd. Cap Screw	2
86	8025708	2J-708	Timing Belt Pulley	1
87	8300362	ST362	5/8" - 18 NF Jam Nut	1
88	8014636	BM636/C	Speed Change Name Plate	1
89	8300618	ST618	10 - 32 x 3/4" C/s, Slotted Screws	2
90	8025693	2J-693	Lubrication Plate	1
91	8300131	ST131	Avdel Choebert Rivets	4
74	8300153	ST153	10/32 UNF x 1/2" Socket Cap Screw	2

Spare Parts 6F LONGITUDINAL VARIFEED BOX

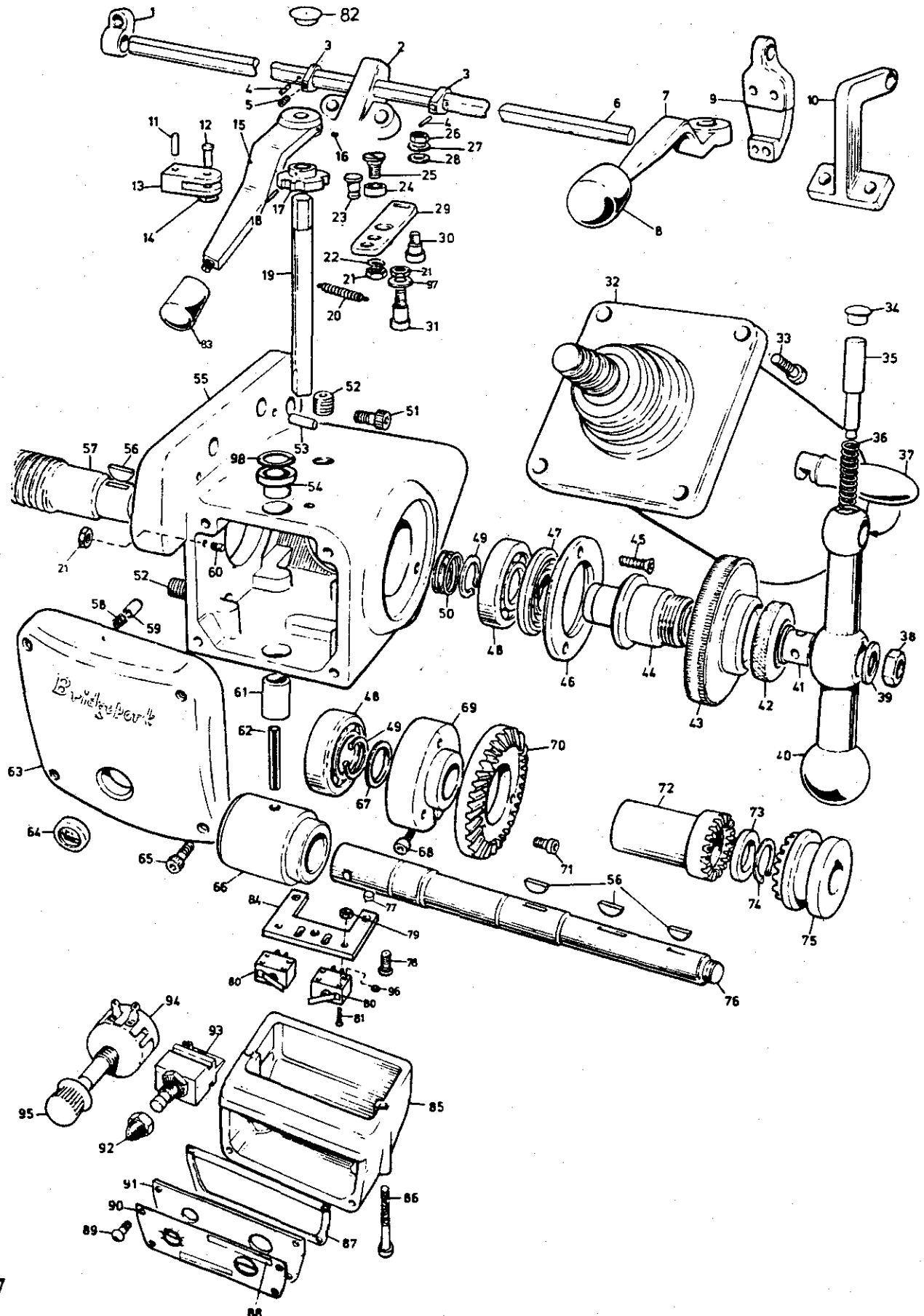

Spare Parts 6F LONGITUDINAL VARIFEED BOX

ITEM NO	COMP NO	PART NO	DESCRIPTION	QTY
1	8001068	F-68	STD. Stop Rod Clamp	1
2	8005123	H-123B	STD. Bracket with hole for power feed	1
3	8001069	F-69	Stop Collar	2
4	8300010	ST 10	1/8" x 1/2" Roll Dowel	2
5	8300219	ST 219	1/4" x 20 x 1/4" Socket Set Screw	2
6	8006034	F-6034	Stop Rod 42" Table	1
7		OF-120	Control Lever for Optics (Obsolete, must order Item 15	1
8	8006073	F-6073	Red Knob Ref. 3200 and Item 19)	1
9	8019107	OF-107	Stop Rod Clamp on Optics	1
10	8019079	OF-79	Optical Bracket with hole for Power Feed	1
11	8300005	ST 5	3/32" x 5/8" Roll Dowel	1
12	8001075	F-75	Fork Pin	1
13	8006027	F-6027	Stop Rod Fork	1
14	8300093	ST 93	Retaining Ring 5115-18	1
15	8006225	F6225/1	Handle (aluminium)	1
16	8300222	ST 222	Grub Screw - 1/4" x 20 x 1/4" Long	1
17	8006028	F-6028	Clutch Detent Cam	1
18	8300574	ST 574	1/8" x 5/8" Long Taper Pin	1
19	8006223	F6223/1	New type shaft for control lever	1
20	8006024	F-6024	Spring to Clutch Arm	1
21	8300352	ST352	1/4" x 20 Locknut	3
22	8300396	ST 396	Lockwasher Type 11	1
23	8006032	F-6032	Clutch Arm Spring Pin	1
24	8006030	F-6030	Clutch Arm Detent Roller	1
25	8006040	F-6040	Detent Roller Pin	1
26	8300338	ST 338	10-32 Hex. Nut	1
27	8300374	ST 374	No. 10 Lockwasher	1
28	8300376	ST 376	3/16" Washer	1
29	8006029	F-6029	Clutch Arm complete with Adaptor Bronze Bush	1
30	8302026	F-6065	Cam Follower	1
31	8006086	F-6086	5/16" x 5/8" - 1/4" - 20 Self Locking Shoulder Screw	1
32	8600001		Motor Assembly	1
33	8300160	ST 160	1/4" x 1/4" Socket Cap Screw	4
34	8006217	F-6217	Plug	1
35	8006216	F-6216	Plunger	1
36	8006218	F-6218	Handle Spring	1
37	8006214	F-6214	Handle	1
38	8300349	ST 349	1/2" - 20 Jam Nut	1
39	8300379	ST 379	Washer 17/32" D. x 1.1&160D" x 3/32"	1
40	8006213	F-6213	Handle	1
41	8006215	F-6215	Crank Handle Bush	1
42	8005069	H-69	Dial Locknut	1
43*	8005078	H-78	Dial with 200 graduations - Imperial (Metric - 8005605)	1
44	8006222	F-6222	Dial Holder Right Hand	1
45	8300316	ST 316	10 - 24 x 1/2" Socket Lead Screws	3
46	8006044	F-6044	Take-up Cap	1
47	8006020	F-6020	Lead Screw Seal	1
48	8302027	F-6072	Bearing FBC 204 NPP	2
49	8300100	ST 100	Retaining Ring 5100-78	1
50	8006033	F-6033	Clutch Spring	1

Items 51 Continued.....

Spare Parts 6F LONGITUDINAL VARIFEED BOX

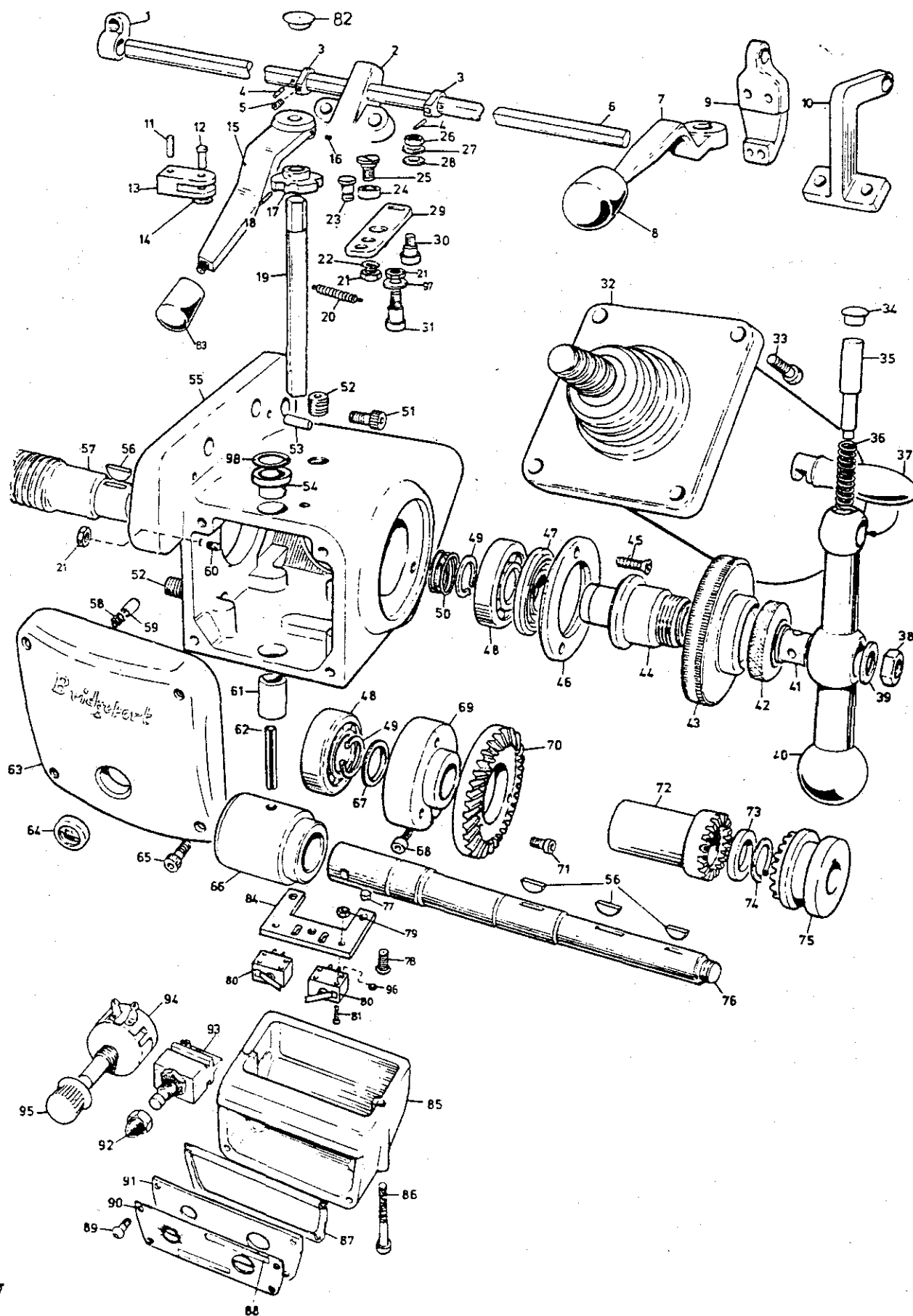

Spare Parts 6F LONGITUDINAL VARIFEED BOX

ITEM NO	COMP NO	PART NO	DESCRIPTION	QTY
51	8300177	ST 177	3/8" - 16 x 1" Hollow Head Cap Screws	3
52	8006071	F-6071	Taper Plug 1/4 NPTF - 3/8" Long	2
53	8300018	ST 18	3/16" x 1" Roll Pin	2
54	8014617	BM 617	B68 - 3 Bronze Bearing	1
55	8006001	F-6001	Main Housing	1
56	8300068/1	ST 68/1	Pre-ground No. 7 Woodruff key	4
57*	8006036	F-6036	FE. Longitudinal Lead Screw (36", 42", 48" also available)	1
58	8006061	F-6061	Spring for Detent Pin	1
59	8006021	F-6021	Detent Pin	1
60	8006031	F-6031	Pin for F-6024 Spring	1
61	8302029	F-6068	N-68-12 Bronze Bearing	1
62	8300020	ST 20	Roll Dowel 3/16" x 1 1/2"	1
63	8006003	F-6003	Side Cover	1
64	8006069	F-6069	Oil Sight B5095	1
65	8300147	ST 147	10-24 x 5/8" Socket Cap Screw	4
66	8006013	F-6013	Coupling	1
67	8006048	F-6048	LH. Thrust Washer	1
68	8300467	ST 467	1/4" - 20 x 1 1/4" Socket HD. Screw	1
69	8006023	F-6023	Gear Mounting Hub	1
70	8006022	F-6022	Drive Shaft Gear (Spiroid)	1
71	8300151	ST 151	10-32 x 3/8" Socket Head Cap Screw	3
72	8006015	F-6015	Clutch-Driver	1
73	8006026	F-6026	RH. Thrust Bearing Washer	1
74	8300094	ST 94	Retaining Ring 5100-78	1
75	8006016	F-6016	Clutch-Driven	1
76	8006049	F-6049	Drive-Shaft	1
77	8006019	F-6019	Switch Mounting Plate Spacer	3
78	8300250	ST 250	10-24 x 5/8" RD. Head Slotted Screw	3
79	8300327	ST 327	4-40 Hex. Nut	4
80	7002063		Sealed Microswitch (Retrofit Assembly)	2
81	8300639	ST 639	4-40 x 3/4" Pan. Head Machine Screw (included in Above)	4
82	8014618	BM 618	Handle Cap	1
83	8006073	F 6073	Red Knob - handle	1
84	8006006	F-6006/1	Switch Mounting Plate (included in Item 80)	1
85	8006002	F-6002	Control Box	1
86	8300468	ST 468	1/4" - 20 x 2 1/2" Socket Head Cap Screw	2
87	8006280	F-6004/1	Control Box Joint	1
88	8006100	F-6100	Lubrication Plate	1
89	8300206	ST 206	8-32 x 1/4" Button HD. Socket Screw	4
90	8006281	F-6004/2	Control Box Scale Plate	1
91	8006004	F-6004	Cover for Control Box	1
92	8500359	ES 359	Boot for AH and H Rapid	1
93	8500358	ES 358	Rapid Traverse Button	1
94	8500357	ES 357	Potentiometer 50KL Taper	1
95	8006101	F-6101	Black Knob 4190/4194 for Potentiometer	1
96	8300393	ST 393	Washer 1/8" bore steel	4
97	8300579	ST 579	Washer 6mm bore steel	1
98	8014619	BM 619	Seal	1
	8006099	F-6099	Mobilube HD140 oil	

Spare Parts 6F CROSS VARIFEED BOX

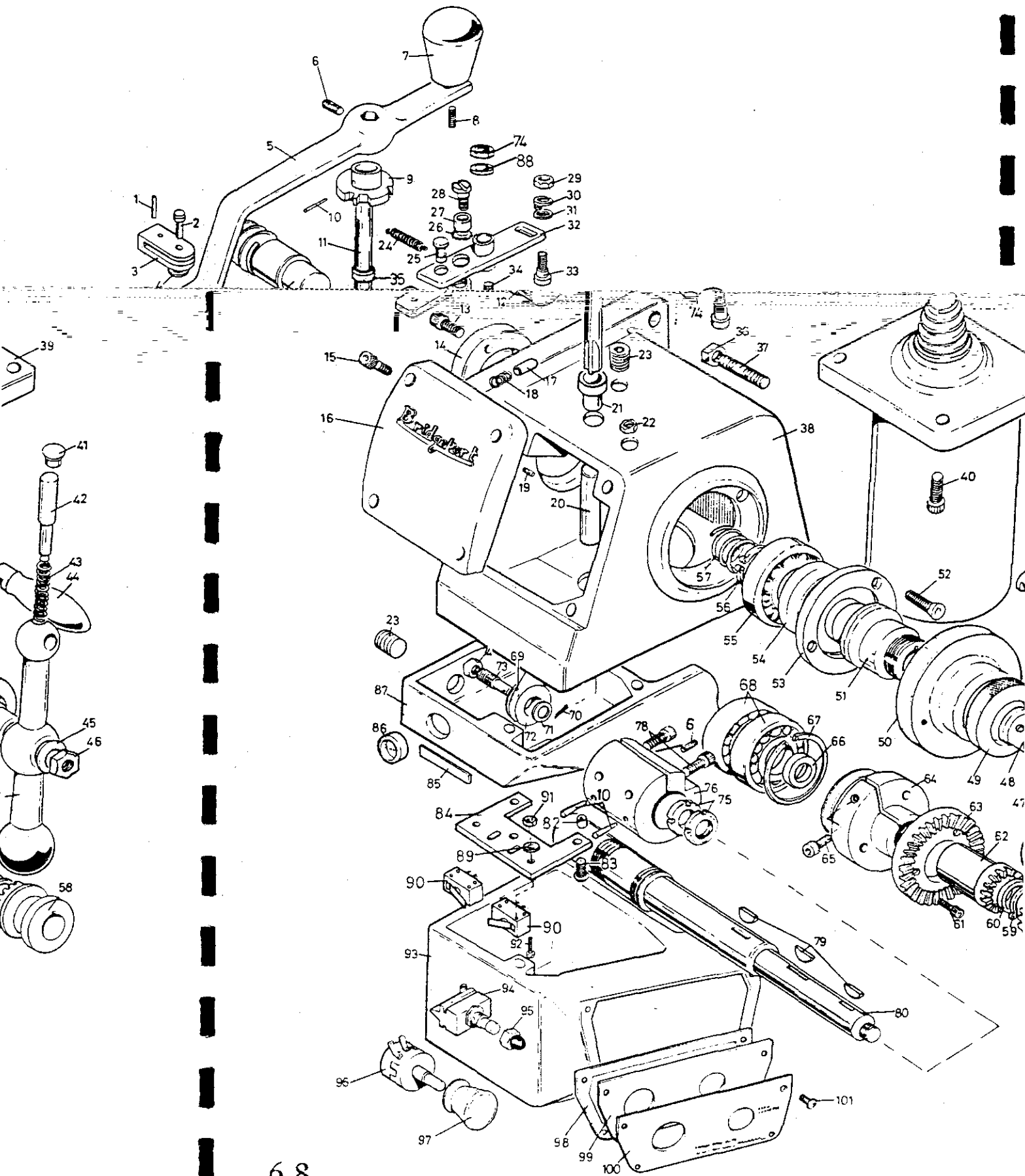

Spare Parts 6F CROSS VARIFEED BOX

ITEM NO	COMP NO	PART NO	DESCRIPTION	QTY
1	8300005	ST 5	Roll Dowel 3/32" x 5/8" Long	1
2	8001075	F-75	Fork Pin	1
3	8006027	F-6027	Stop Rod Fork	1
4	8300093	ST 93	Fastener	1
5	8002018	FX-6018/1	Control Lever Polished	1
6	8300222	ST222	5/16" x 18 x 1/2" Socket Set Screw	2
7	8006073	F-6073	Red Knob Ref: 3200	1
8	8300234	ST 234	Socket Set Screw 3/8" UNC x 16 x 3/4"	1
9	8006028	F-6028	Clutch Detent Cam (Not Bronze Bearing)	1
10	8300574	ST574	Taper Pin	2
11	8002005	FX-6005	Clutch and Limit Switch Actuating Shaft	1
12	8002036	FX-6036	Cross Screw	1
13	8300149	ST 149	Socket Cap Screw 10-24 x 5/8"	3
14	8002237	FX-6237	Bearing Cap	1
15	8300147	ST 147	10-24 x 1/2" Socket Cap Screw	4
16	8002003	FX-6003	Power Feed Top Side Cover	1
17	8006021	F-6021	Detent Pin	1
18	8006061	F-6061	Spring for Detent Pin	1
19	8006031	F-6031	Pin for F-6024 Spring	1
20	8302029	F-6068	N-68-12 Bronze Bearing	1
21	8014617	BM 617	Bearing Oilite 3/8" dia. x 1/2" x 3/8"	1
22	8300230	ST 352	1/4" x 20 UNC Chem Blacked Locknut	1
23	8006071	F-6071	Taper Plug 1/4" NPTF - 3/8" Long	2
24	8006024	F-6024	Spring for Clutch Arm	1
25	8006032	F-6032	Clutch Arm Spring Pin	1
26	8300396	ST 396	Lockwasher Type 11	1
27	8006030	F-6030	Clutch Arm Detent Roller	1
28	8006040	F-6040	Detent Roller Pin	1
29	8300338	ST 338	10-32 UNF Hex. Nut	1
30	8300374	ST 374	No. 10 Lockwasher	1
31	8300376	ST 376	3/16" Washer (Chem Blacked)	1
32	8006029	F-6029	Clutch Arm Complete with Adaptor Bronze Bush	1
33	8302026	F-6065	Cam Follower	1
34	8006086	F-6086	5/16" x 5/8" - 1/4" 20 Self Locking Shoulder Screw	1
35	8014619	BM 619	Rubber seal	1
36	8300358	ST 358	3/8" UNC full nut	4
37	8002236	FX-6236	Fixing Stud	4
38	8002001	FX-6001	Main Housing	1
39	8600001		Motor Assembly	1
40	8300160	ST 160	Socket Cap Screw 1/4" UNC x 1/4"	4
41	8006217	F-6217	Plug	1
42	8006216	F-6216	Plunger	1
43	8006218	F-6218	Handle Spring	1
44	8006214	F-6214	Handle	1
45	8300379	ST 379	Washer 1/8" x 1" x 1/8"	1
46	8300349	ST 349	Jam Nut	1
47	8002213	FX-6213	Handle	1
48	8006215	F-6215	Crank Handle Bush	1
49	8005069	H-69	Dial Locknut	1
50*	8005078	H-78	Dial with 200 graduations - Imperial (Metric - 8005605)	1

Items 51 Continued.....

Spare Parts 6F CROSS VARIFEED BOX

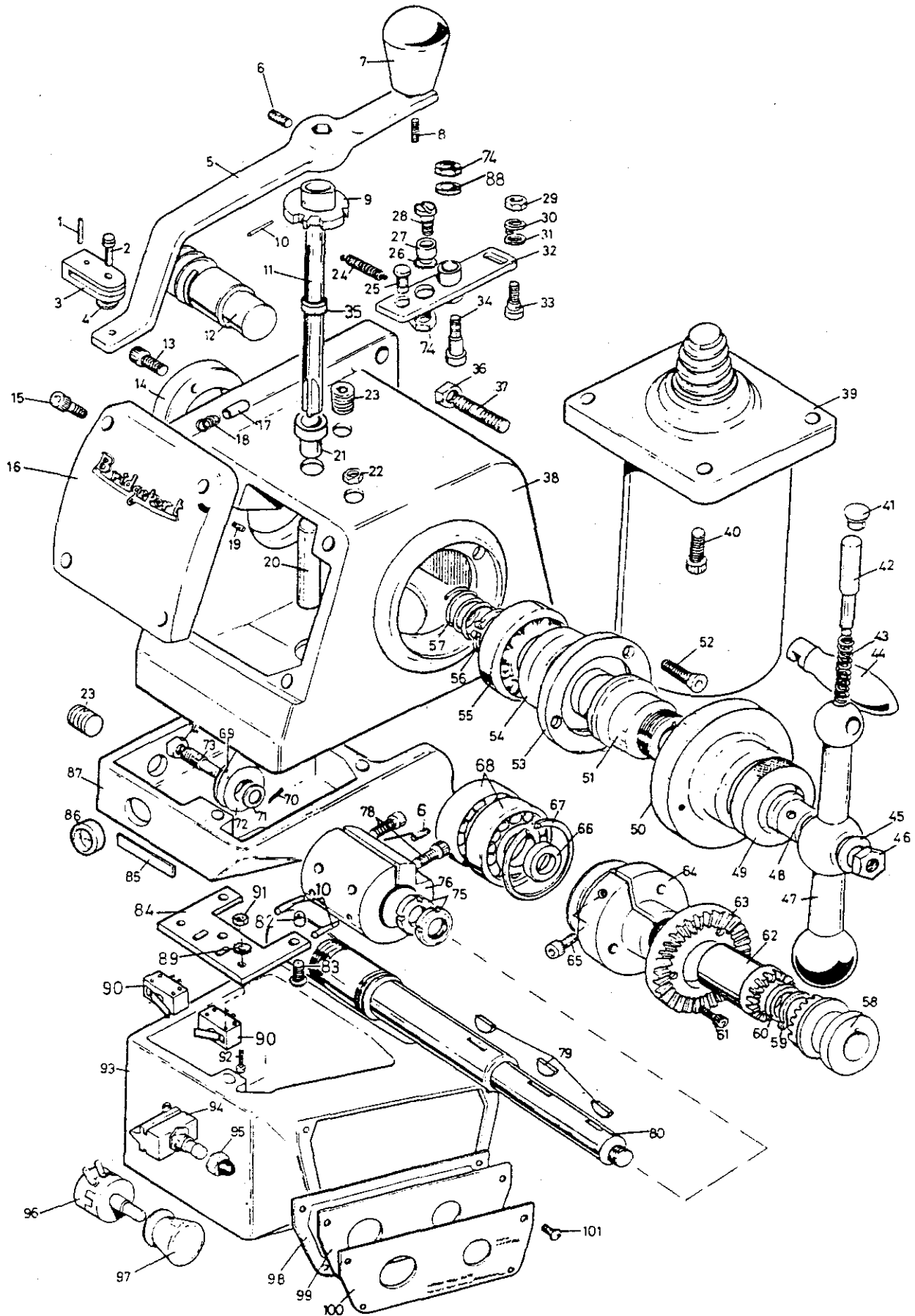

Spare Parts

6F CROSS VARIFEED BOX

ITEM NO	COMP NO	PART NO	DESCRIPTION	QTY
51	8006222	F-6222	Dial Holder RH.	1
52	8300316	ST 316	Csk. Hd. Socket Screw 10 - 24 x 1/2" UNC	3
53	8006044	F-6044	Take-up Cap	1
54	8006020	F-6020	Head Screw Seal	1
55	8302027	F-6072	Bearing 204KK with Boulter B3	1
56	8300100	ST 100	Retaining Ring 5100-78	1
57	8006033	F-6033	Clutch Spring	1
58	8006016	F-6016	Clutch Driven (not driver)	1
59	8300094	ST 94	Retaining Ring 5100-78	1
60	8006026	F-6026	RH. Thrust Bearing Washer	1
61	8300151	ST 151	10-32 x 3/8" Socket Head Cap Screw	3
62	8006015	F-6015	Clutch Driver	1
63	8006022	F-6022	Drive Shaft Gear (Spiroid)	1
64	8002430	FX-6239/1	Gear Mounting Hub	1
65	8300467	ST 467	1/4" - 20 x 1 1/4" Socket HD. Screw	1
66	8006048	F-6048	LH. Thrust Washer	1
67	8300548	ST 548	Retaining Ring	1
68	8302016	H 76	Bearing LJ 20WRR	1 PR
69	8002227	FX-6227	Spring oil carrier (approx. 10")	1
70	8300107	ST 107	Split Pin 1/16" x 1/2" Long	1
71	8300376	ST 376	3/16" Chem Blacked Washer	1
72	8002231	FX-6231	Roller Pulley	1
73	8002232	FZ-6232	Roller Pin	1
74	8300352	ST352	1/4" UNC Thin Locknut	3
75	8002230	FX-6230	Retaining Nuts 3/4" x 16 UNF	2
76	8002013	FX-6013	Coupling	1
78	8300161	ST161	1/4" x 1" Socket Cap Screw	2
79	8300068	ST 68	Pre-Ground Woodruff Key No. 7	3
80	8002049	FX-6049	Drive Shaft	1
82	8006019	F-6019	Switch Mounting Plate Spacer	2
83	8300250	ST250	10 - 24 x 5/8" Round Hd. Slotted Screw	2
84	8006006	F-6006/1	Switch Mounting Plate	1
85	8006100	F-6100	Lubrication Plate	1
86	8006069	F-6069	Oil Sight	1
87	8002226	F-6226	Oil Sump	1
88	8300579	ST579	6mm Bore Steel Washer	1
89	8300393	ST393	1/8" Bore Steel Washer	4
90	8500630	ES 630	Sealed Microswitch	2
91	8300327	ST327	4 - 40 Hex. Nut	4
92	8300639	ST 639	4 - 40 x 3/4 Pan. Hd. Machine Screw	2
93	8006002	F-6002	Control Box	1
94	8500358	ES358	Rapid Traverse Button	1
95	8500359	ES359	Switch Seal	1
96	8500357	ES357	Potentiometer	1
97	8006101	F-6101	Black Knob for Potentiometer	1
98	8006004	F-6004/1	Control Box Joint	1
99	8006004	F-6004	Cover for Control Box	1
100	8006281	F-6004/2	Control Box Scale Plate	1
101	8300206	ST206	8 - 32 x 1/4" Button Hd. Socket Screw	4
102	8002034	FX6034	Stop Rod	1

Spare Parts E-HEAD

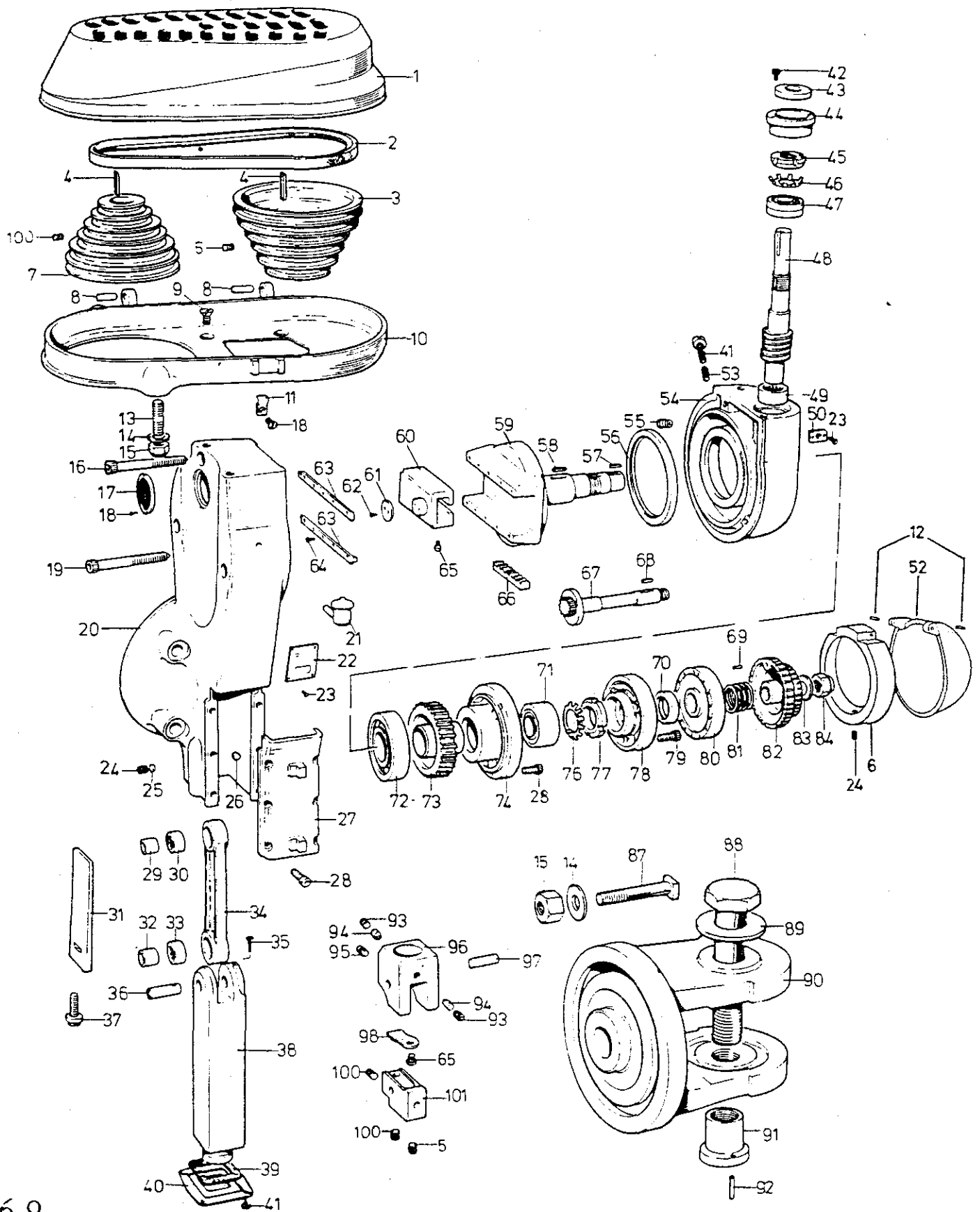

Spare Parts E-HEAD

ITEM NO	COMP NO	PART NO	DESCRIPTION	QTY
1	8000011	E-11	Belt Housing Cover	1
2	8300397	ST 397	Vee Belt	1
3	8000005	E-5	Worm Shaft Pulley	1
4	8300090	ST 90	Key 3/16" x 3/16" x 1 - 3/4"	2
5	8300230	ST 230	5/16" - 18 x 1/2" Set Screw	2
6	8000101	E-101	E Head Guard Ring	1
7	8000004	E-4	Motor Pulley	1
8	8300109	ST 109	1/8" x 2 1/4" Pin	2
9	8300318	ST 318	1/4" - 20 x 1/2" Flat Head Screw	4
10	8000010	E-10	Belt Housing	1
11	8000066	E-66	Belt Cover Clip	1
12	8300012	ST 12	Roll Dowel 1/8" x 1/4"	2
13	8300239	ST 239	Motor Mounting Ring Stud	2
14	8300381	ST 381	Motor Mounting Ring Stud Washer	6
15	8300357	ST357	Motor Mounting Ring Stud Nut	2
16	8300171	ST 171	5/16" - 18 x 2 3/4" Cap Screw	1
17	8000048	E-48	Air Vent Cover	1
18	8300295	ST 295	Pan Hd. Screw No. 8 - 32 x 3/8"	3
19	8300172	ST 172	5/16" UNC x 3 1/2" Socket Set Screw	2
20	8000001	E-1	Ram Housing	1
21	8300120	ST 120	90° Elbow Oiler 5/16" x 1/8" Gas	1
22	8000065	E-65	Nameplate (Speed)	1
23	8300116	ST116	Drive Pins No. 2 x 1/4"	6
24	8300219	ST 219	1/4" - 20 x 1/4" Socket Set Screw	2
25	8000092	E-92	Brass Plug	1
26	8300403	ST 403	Felt Plug	1
27	8000007	E-7	Ram Cover	1
28	8300158	ST 158	1/4" - 20 x 1/2" Cap Screw	9
29	8302005	E-37	No. 15 - 1312 Inner race	1
30	8302006	E-38	No. GL - 1612 x bearing	1
31	8000008	E-8	Gib	1
32	8302007	E-39	No. 15 - 8120 SC Inner race	1
33	8302008	E-40	No. GB 1212 X Bearing	1
34	8000017	E-17	Connecting Rod	1
35	8300264	ST 264	Ram Crank Pin Lock Screw	1
36	8000022	E-22	Ram Crank Pin	1
37	8005088	H-88	Gib Screw	1
38	8000015	E-15	Ram	1
39	8000031	E-31	Wiper-Felt	1
40	8000030	E-30	Wiper Plate	1
41	8300253	ST 253	5 - 40 x 5/16" Round Head Screw	4
42	8300148	ST 148	No. 10 - 24 x 3/8" Cap Screw	3
43	8303107	E-47	W1507531 - R4 Oil Seal	1
44	8000024	E-24	Worm Bearing Cover	1
45	8000043	E-43	No. N-04 Locknut	1
46	8000044	E-44	No. W-04 Lockwasher	1
47	8000034	E-34	No. LJT 21L Bearing	1 PR
48	8000009	E-9	Worm and Shaft	1
49	8302004	E-36	No. B - 1212X Bearing	1
50	8000094	E-94	Rotation Nameplate	1

Items 51 Continued.....

Spare Parts E-HEAD

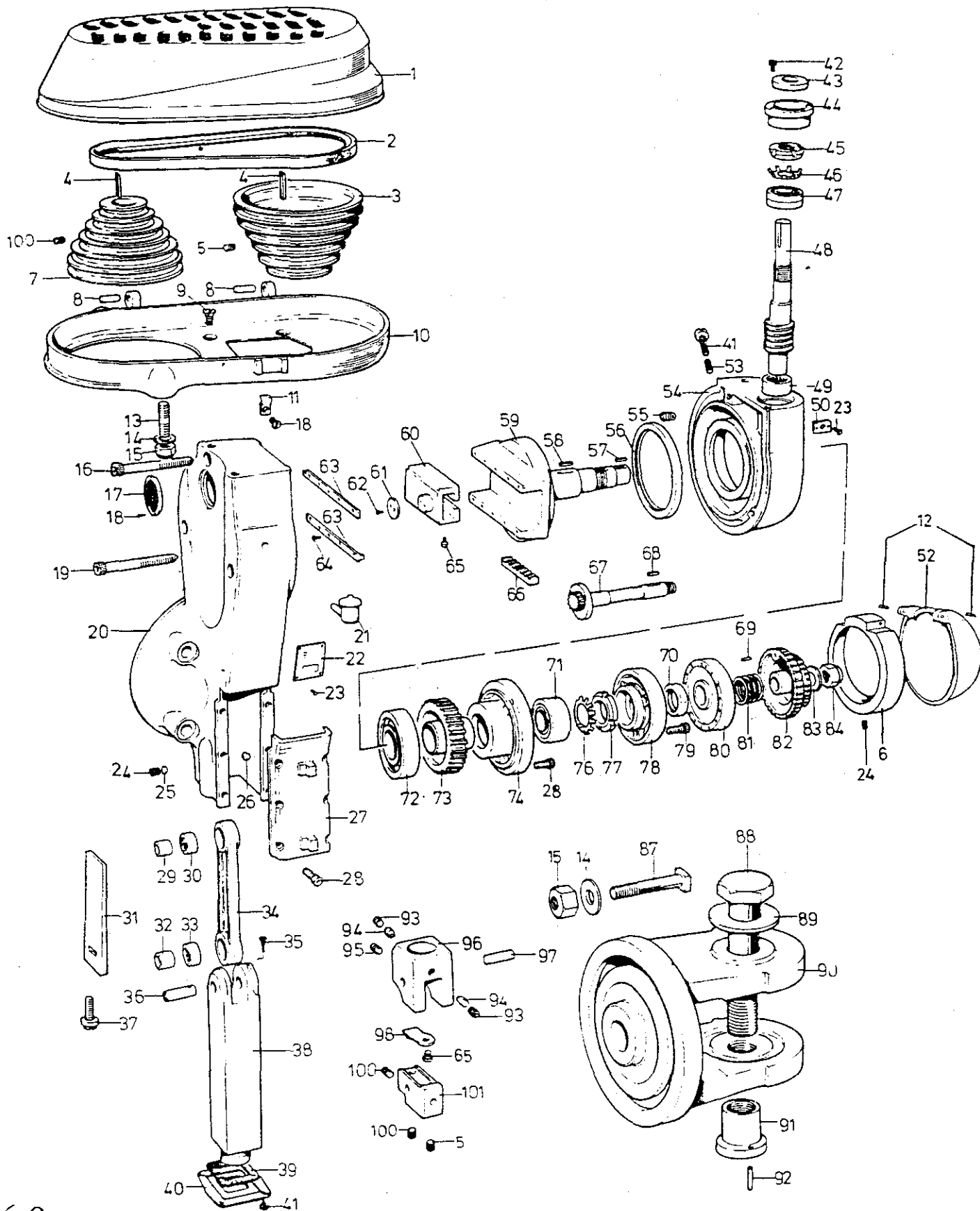

Spare Parts E-HEAD

ITEM NO	COMP NO	PART NO	DESCRIPTION	QTY
51	8300116	ST 116	Drive Pins No. 2 x ¼"	2
52	8000100	E-100	Plastic E Head Cover	1
53	8300136	ST 136	1/8" x 3/8" Slotted & Counter Bored, Drilled and Tapped Grub Screw	1
54	8000002	E-2	Gear Housing	1
55	8300137	ST 137	1/8" BSP Blanking Plug	1
56	8303015	E-45	Oil Seal 42531831 - R4	1
57	8300074	ST-74	1/8" sq. x 3/8" long key	1
58	8300087	ST 87	3/16" sq. x 13/16" long key	1
59	8000013	E-13	Crank and Shaft	1
60	8000014	E-14	Crankpin Block	1
61	8000025	E-25	Bearing Retaining Washer	1
62	8300307	ST 307	No. 5 - 40 x ¼" Flat Head Screw	2
63	8000020	E-20	Crankpin Block Hold-Down	2
64	8300313	ST 313	No. 10 - 24 x 3/8" Flat Head Screw	10
65	8300255	ST 255	No. 8 - 32 x 3/8" Washer Head Screw	4
66	8000019	E-19	Rack	1
67	8000052	E-52	Locking Bolt and Gear	1
68	8300077	ST 77	Key 1/8" x ¼" Long	1
69	8300043	ST 43	3/16" x 3/8" Pin	1
70	8303016	E-46	W15008 738 - R4 Oil Seal	1
71	8302001	E-32	Bearing No. 5205	1
72	8302002	E-33	Bearing No. R330	1
73	8000021	E-21	Worm Gear	1
74	8000003	E-3	Gear Housing Cover	1
76	8000042	E-42	No. W-05 Lockwasher	1
77	8000041	E-41	N-05 Locknut	1
78	8000018	E-18	Crank Bearing Cover	1
79	8300160	ST 160	¼" - 20 x ¾" Cap Screw	3
80	8000016	E-16	Stroke Adjustment Plate	1
81	8000062	E-62	Dial Spring	1
82	8000006	E-6	Stroke Adjustment Dial	1
83	8300378	ST 378	Washer 7/16" x 7/8"	1
84	8300346	ST 346	7/16" - 20 Acorn nut x 11/16" A/F	1
87	8022017	Q-17	Tee Bolt	4
88	8005038	H-38	Adaptor Lock Bolt	1
89	8005039	H-39	Washer	1
90	8000145	E-145	Ram Adaptor	1
91	8005040	H-40	Adaptor Lock Nut	1
92	8300125	ST 125	3/16" x ½" Steel Dowel	1
93	8300229	ST 229	5/16" - 18 x 5/16" Set Screw	2
94	8000028	E-28	Clapper Box Clamp Shoe	2
95	8300208	ST 208	No. 10 - 24 x ¼" Set Screw	1
96	8000026	E-26	Clapper Box	1
97	8300059	ST 59	5/16" x 1-7/8" Pin	1
98	8000012	E-12	Clapper Spring	1
100	8300231	ST 231	5/16" - 18 x 5/8" Set Screw	1
101	8000027	E-27	Clapper	1
	8600026	E50/51	E Head motor supplied on request	1

Spare Parts M-HEAD

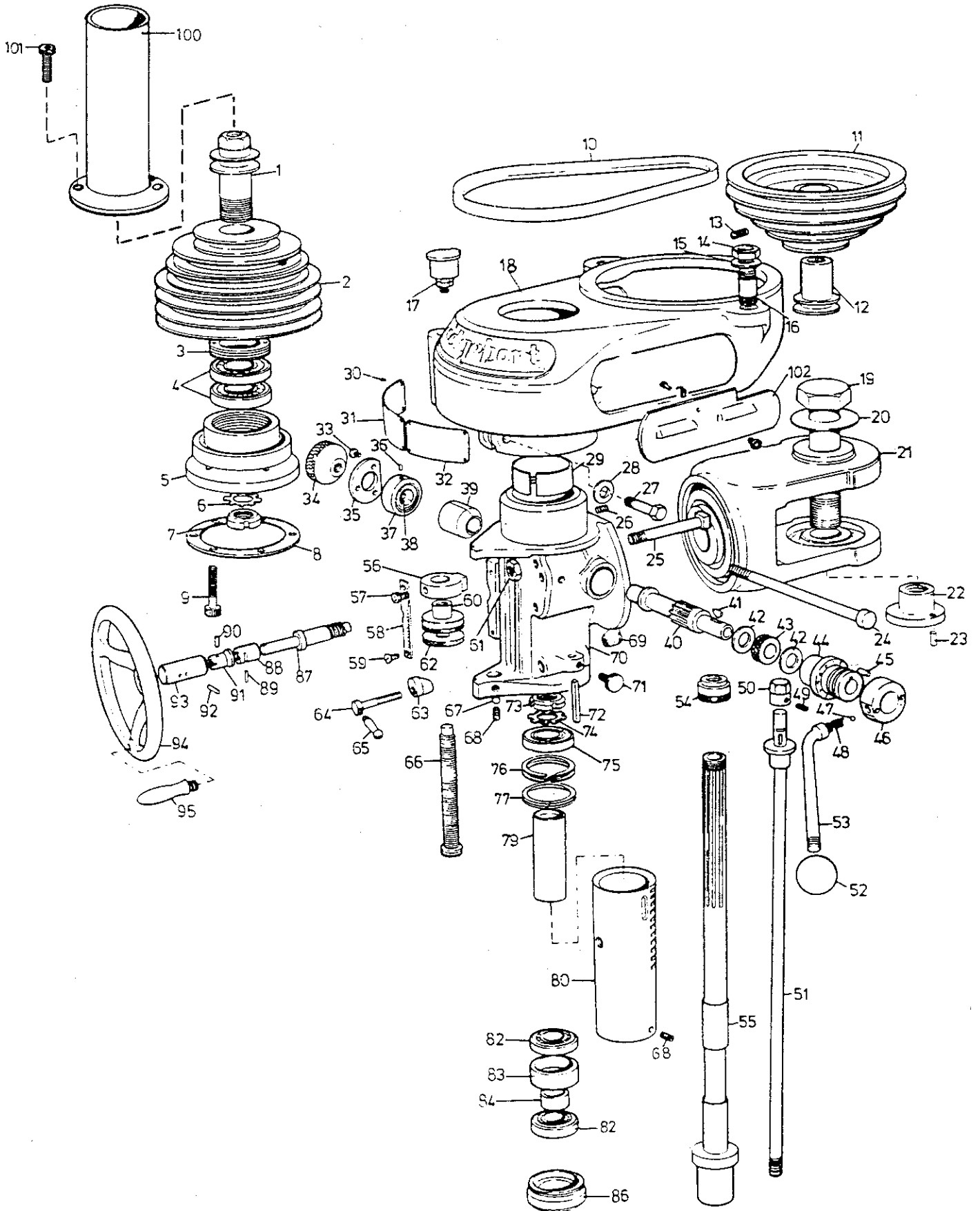

Spare Parts M-HEAD

ITEM NO	COMP NO	PART NO	DESCRIPTION	QTY
1	8009017	M-17/A	Spindle Pulley Hub, Single Belt Drive	1
2	8009018	M-18/A	Spindle Pulley, Single Belt Drive	1
3	8009021	M-21	Bearing Retainer Ring	1
4	8009219	M 219	Spindle Pulley Hub Ball Bearing	1 PR
5	8009020	M-20	Bearing Housing	1
6	8007273	J-273	No. W-05 Bearing Lock Washer	1
7	8007272	J-272	No. N-05 Bearing Lock Nut	1
8	8009084	M-84	Paper Gasket	1
9	8300164	ST 164	¼" x 1¾" Socket Head Cap Screw	6
10	8303786	M 86	V-Belt	1
11	8009030	M-30/A	Motor Pulley, Single Belt Drive	1
12	8009031	M-31	Motor Pulley Hub	1
13	8300218	ST 218	5/16" - 18 x ¼" Set Screw	1
14	8300349	ST 349	½" V.N.F. Full Nut Hexagon	2
15	8300379	ST 379	½" B.S.F. 1" OD. x ½" Thick Washer	2
16	8009070	M-70	Motor Mounting Ring Stud	2
17	8303777	M 56	Gits No. 2551 Oil Cup	1
18	8009002	M-2/S	Belt Housing Single Belt Drive	1
19	8005038	H-38	Lock Stud	1
20	8005039	H-39	Lockwasher	1
21	8005037	H-37	Adaptor for fitting on back of machine	1
22	8005040	H-40	Locknut	1
23	8300044	ST 44	3/16" x 5/8" Steel Dowel	1
24	8009032	M-32	Quill Feed Clutch Bolt	1
25	8009064	M-64	T-Bolt	4
26	8300217	ST 217	5/16" - 18 x 3/8" Set Screw	1
27	8300445	ST 445	½" x 13 x 3¼" Hex. Head Screw	1
28	8300383	ST 383	½" ID. x 7/8" OD. Washer	1
29	8009058	M-58	Brass Quill Skirt	1
30	8300131	ST 131	Chebaert Rivets	8
31	8009100	M-100	Instruction Plate	1
32	8009102	M101/A	5100 r.p.m. speed plate	1
33	8300262	ST262	10 - 24 x 3/8" x 1/16" Flat Headed Screw	3
34	8009040	M-40	Quill Feed Clutch Knob	1
35	8009039	M-39	Spring Cover	1
36	8009063	M-63	Outside Spring Pin	1
37	8009038	M-38	Clock Spring	1
38	8009089	M-89	Pinion Spring Pin	1
39	8009037	N-37	Split Bushing	1
40	8009034	M-34	Quill Feed Pinion	1
41	8300066	ST 66	No. 30 Woodruff Key	1
42	8300367	ST367	1" x 5/8" x 1/16" Thick Fibre Washer	2
43	8009035	M-35	Quill Feed Worm Wheel	1
44	8009033	M-33	Quill Feed Hub	1
45	8300042	ST 42	3/16" x ¼" straight pin	1
46	8009053	M-53	Rack Feed Handle Hub	1
47	8300132	ST 132	Steel Ball 3/16" Dia.	1
48	8300565	ST 565	3/16" dia. Spring	1
49	8300219	ST 219	½" UNC x 20 x ¼" Socket Set Screw	1
50	8009028	M-28	Draw Bar Knob	1

Items 51 Continued.....

Spare Parts M-HEAD

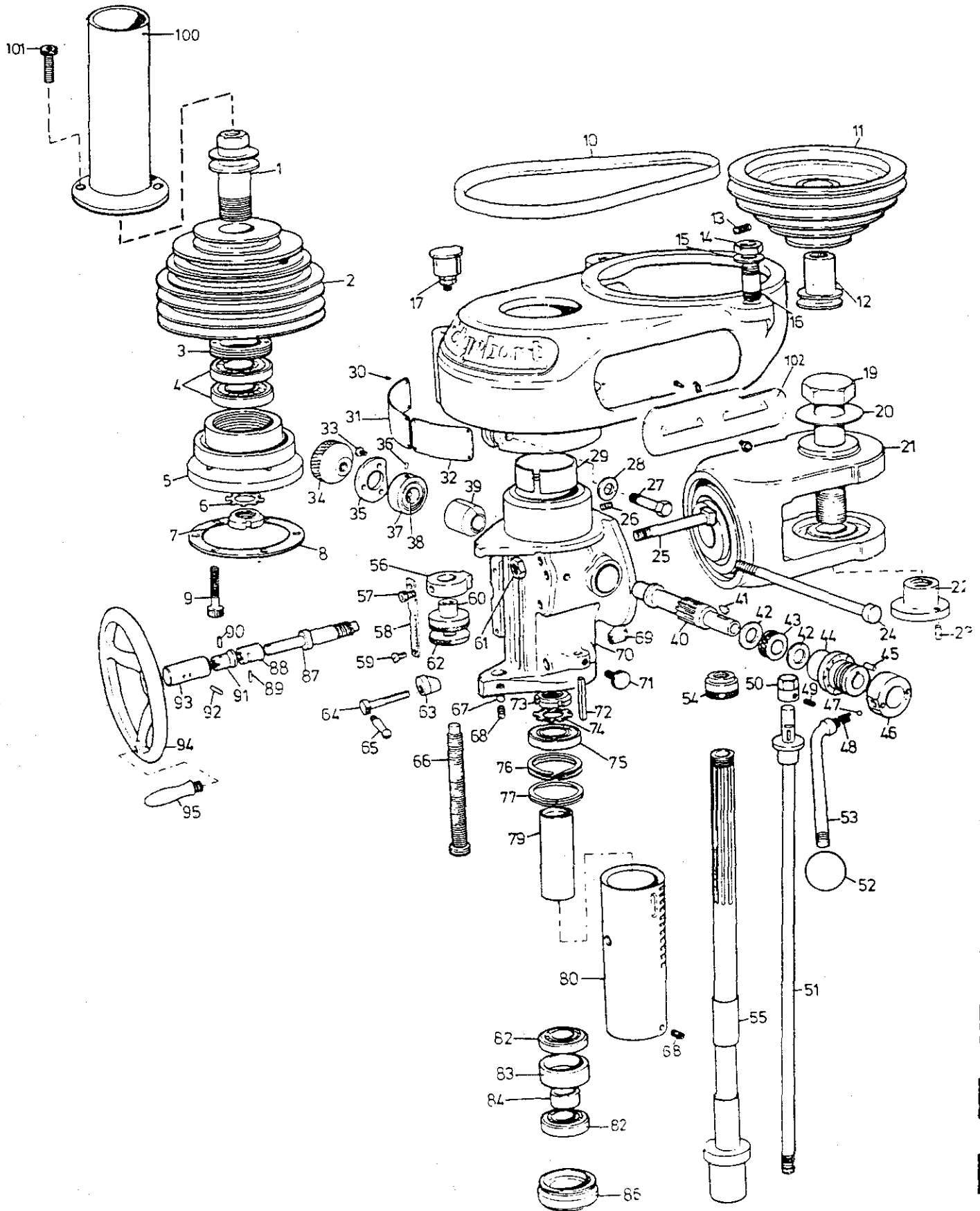

Spare Parts M-HEAD

ITEM NO	COMP NO	PART NO	DESCRIPTION	QTY
51	8009027	M-27/C	Drawbar, Single Belt No. 7 or No. 2 Spindle	1
52	8300408	ST 408	Black Plastic Ball 1" Dia.	1
53	8009054	M-54	Rack Feed Handle	1
54	8009026	M-26	Drawbar Nut (Left Hand Thread)	1
55	8009004	M-4/A	Spindle, Single Belt No. 2 Morse Taper (with M6 fitted)	1
	8009004	M-4/B	Spindle, Single Belt No. 7B & S Taper	1
56	8009022	M-22	Micrometer Stop	1
57	8300192	ST 192	7/16" x 20 x 1/2" Cap Screw	1
58*	8009041	M41/A/B	Micrometer Scale /B Metric	1
59	8300252	ST 252	Round Headed Screw 6-32 x 3/16" long	2
60	8007038	J-38	Micrometer Nut	1
61	8300341	ST 341	3/8" x 16 Hex. Nut	4
62*	8009024	M-24	Micrometer Lock Nut	1
63	8009049	M-49	Quill Lock Sleeve Drilled	1
64	8009048	M-48	Quill Lock Bolt	1
65	8009047	M-47	Quill Lock Bolt Handle	1
66*	8009025	M-25	Micrometer Screw	1
67	8009088	M-88	Brass Plug 3/16" x 3/16"	1
68	8300219	ST 219	1/4" - 20 x 1/4" long socket set screw	2
69	8009050	M-50	Quill Lock Sleeve Tapped	1
70	8009001	M-1	Quill Housing	1
71	8009051	M-51	Indicator Rod Clamp Screw	1
72	8009052	M-52	Indicator Rod	1
73	8000041	E-41	No. N-05 Bearing Lock Nut	1
74	8000042	E-42	No. W-05 Bearing Lock Washer	1
75	8302056	M-220	RMM 205 KCR Fafnir Bearing	
76	8009218	M-218	Wallace Barnes Wavy Washer	
77	8009204	M-204	Wavy Spring Spacer	1
79	8009010	M-10	Long Spacer	1
80	8009003	M-3	Quill	1
82	8302057	M-221	5mm 205 W1-CR-DUL-FS-275 Fafnir Bearing	1 PR
83	8009009	M-9	0.750 Outside Bearing Spacer	1
84	8009008	M-8	0.750 Inside Bearing Spacer	1
86	8009005	M-5	Nose Cap	1
87	8009046	M-46	Quill Feed Worm Shaft	1
88	8009055	M-55	Bronze Worm Bushing	1
89	8300035	ST 35	1/8" x 1" hardened straight pin	1
90	8300010	ST 10	Taper Pin	1
91	8009045	M-45	Quill Feed Worm Hub	1
92	8009062	M-62	Straight Pin 3/16" x 1"	1
93	8009044	M-44	Quill Worm Feed Hand Wheel Hub	1
94	8009042	M-42	Quill Worm Feed Handwheel	1
95	8009043	M-43	Quill Worm Feed Handwheel Handle	1
96	8500061	ES 61	Motor Switch	
97	8600126	M-83	M-Head Motor 380/440v - 3 PH - 50 HZ	
98	8014219	BM219	M HeadBelt Guard	1 set
99	8300426	ST426	1 1/4" AF Spanner	1
100	8300427	ST427	1 1/16" x 3/4" AF Spanner	
101			Knob Model No 1069	1pr
102	8014219		Belt Guard M-Head	1pr
103			Large Clip	1pr
104			Rd. Hd. Screw	1pr

Spare Parts CENTRALISED LUBRICATION SYSTEM

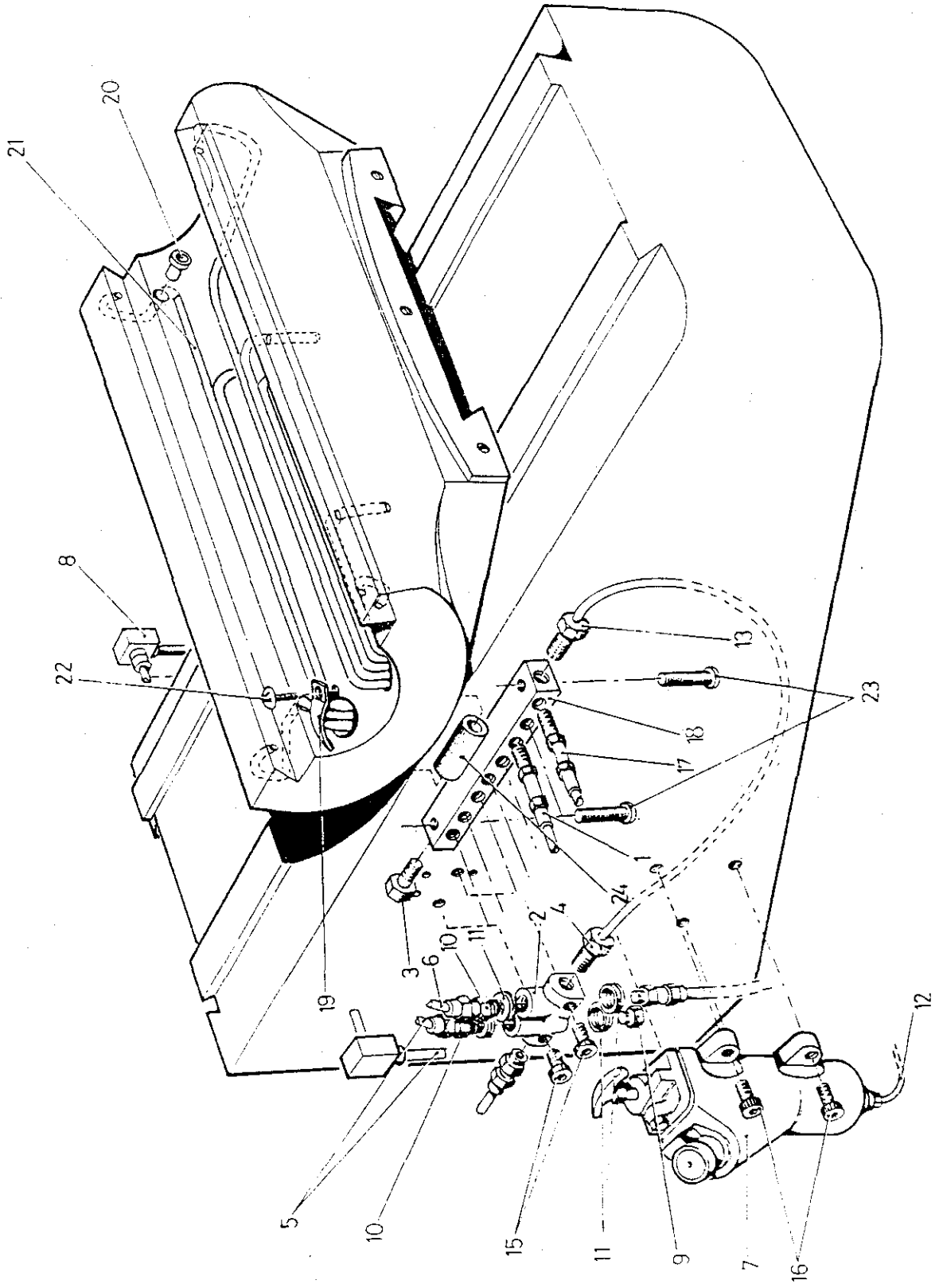

Spare Parts

CENTRALISED LUBRICATION SYSTEM

ITEM NO.	COMP NO.	PART NO.	DESCRIPTION	QTY	WHERE USED
1	8303702		Meter units	3	
2	8303723		Six-way double junction	1	ONE-SHOT
3	8303740		Plug	1	KNEE
4	8303731		Bushing	1	JUNCTION
5	8303715		Nylon tubing 5/32" O.D.	4 ft.	
6	8303711		Brass pipe x 5/32" O.D.	1.5 ft.	
7	8303701		Teclamit Lubricator	1	
8	8303736		Elbow adaptor	2	ONE-SHOT
9	8303740		Plug	1	KNEE
10	8303731		Bushing	4	ASSEMBLY
11	8303745		Olives	4	
12	8303715		Cone nylon tubing 5/32" O.D.	5 ft.	
13	8303708		Special hose assembly	2 ft.	
15	8300161	ST 161	¼ UNC x 1" long cap screw	2	(6-way)
16	8300162	ST 162	¼ UNC x 1¼" long cap screw	4	(pump)
17	8303703		Meter unit	5	
18	8303726		Ten-way junction	1	ONE-SHOT
19	8303718		Clips	2	SADDLE
20	8303733		Drive bushings	6	ASSEMBLY
21	8303715		Nylon tube 5/32" O.D.	6 ft.	
22	8300119	ST 119	10-32 x ½" posi screw	2	(hose clips)
23	8300566	ST 566	¼" UNC x 1¼" pan head screw	2	(10 way)
24	8300489		¼" P.V.C. sleeve 13mm I.D.	2	

Spare Parts

HEIDENHAIN D.R.O. VRZ 710

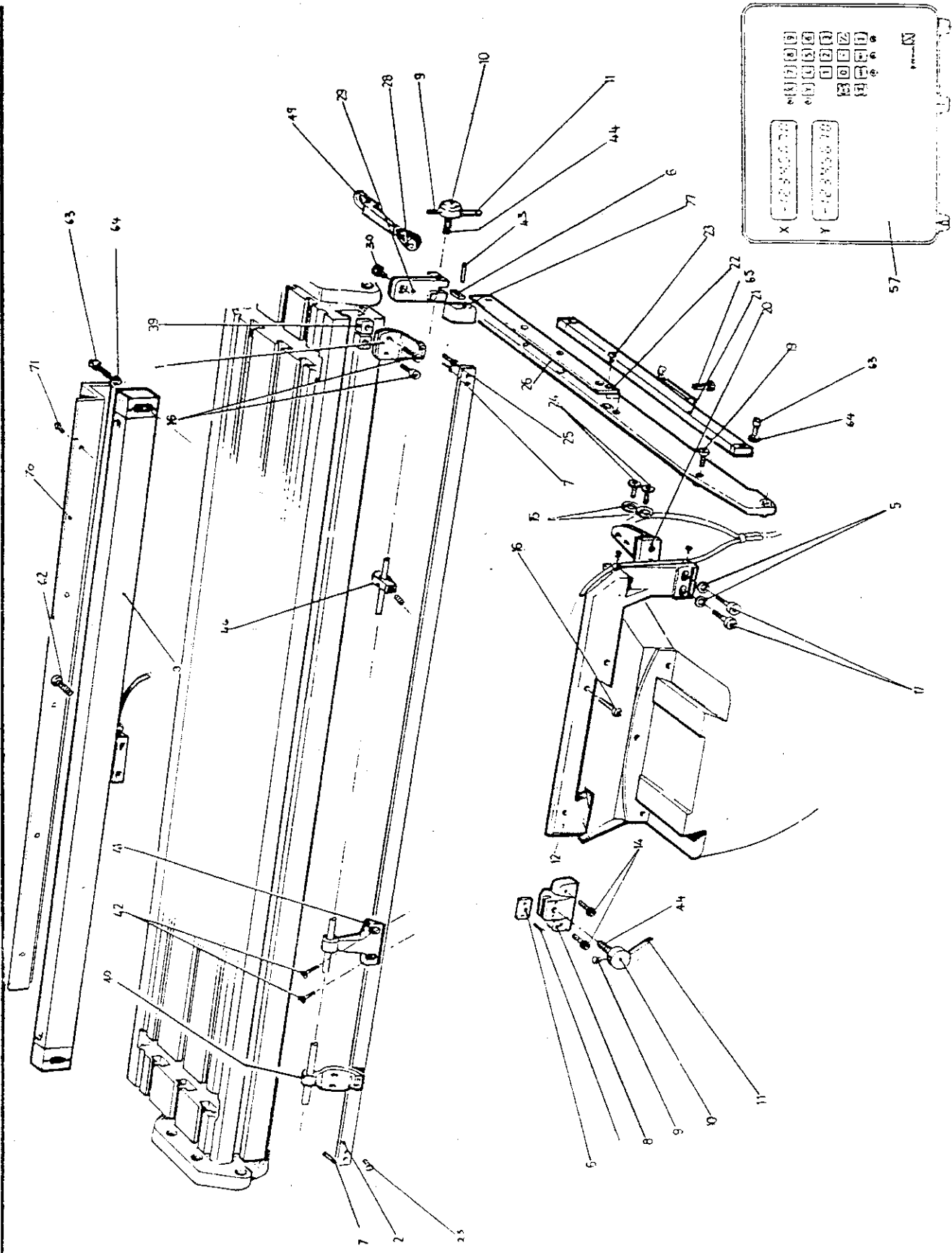

Spare Parts Heidenhain Digital Read-Out VRZ 710

ITEM NO	COMP NO	PART NO	DESCRIPTION	QTY
1	8012024	0 - 24	Binding strip dog (2 hand feed only)	1
2	8012313	0 - 313	Bind strip - 42"	1
3	8036064	DR 64	X axis transducer	1
4	8300162	ST 162	Socket cap screw	4
5	8300557	ST 557	1/4" bore std washer (chemically blackened)	6
6	8012011	0 - 11	Binding bracket plate	2
7	8300008	ST 8	Roll dowel 1/8" x 3/8" long	2
8	8012014	0 - 14	Table binder bracket	1
9	8300503	ST 53	1/4" - 28 UNF x 1/4" socket cap screw	2
10	8012018	0 - 48	Binder hub	2
11	8012015	0 - 15	Binder handle	2
12	8036054	DR 54	Dovetail bracket	1
14	8300165	ST 165	5/16" - 18 UNC x 5/8" socket cap screw	2
16	8300154	ST 154	10 - 32 UNF x 3/4" long socket cap screw	4
17	8300162	ST 162	Socket cap screw	4
18				
19	8300177	ST 177	Socket cap screw	3
20	8036052	DR 52	Cross reader bracket - New Version - 8036080	1
21	8036065	DR 65	Y axis transducer	1
22	8004038	G 38	Saddle locking strip 12"	1
23	8300244	ST 244	10 - 32 UNF x 5/16" round head screw	3
25	8300317	ST 317	1/4" - 20 UNC x 1/2" c'sunk socket head screw	2
26	8036053	DR 53	Cross beam bracket	4
27	8036006	DR 6/A	Beam packing block	2
28	8006073	F 6073	Red knob	1
29	8012010	0 - 10	Cross travel binder bracket	1
30	8300167	ST 167	5/16" UNC x 1" long socket cap screw	2
39	8012308	0 - 308	'T' slot nut	4
40	8019107	OF 107	Securing bracket	1
41	8036005	DR 5	DRO feed knock off bracket	1
42	8301014	ST 1014	Head screw 1/4" UNC x 3/4" c'sunk	2
43	8300007	ST 7	1/8" dia. x 1/4" long roll dowel	4
44	8300177	ST 177	3/8" UNC x 1" socket cap screw	2
45	8005123	H-123	Table stop bracket	1
46	8001069	F-69	Stop collar	2

Spare Parts

HEIDENHAIN D.R.O. VRZ 710

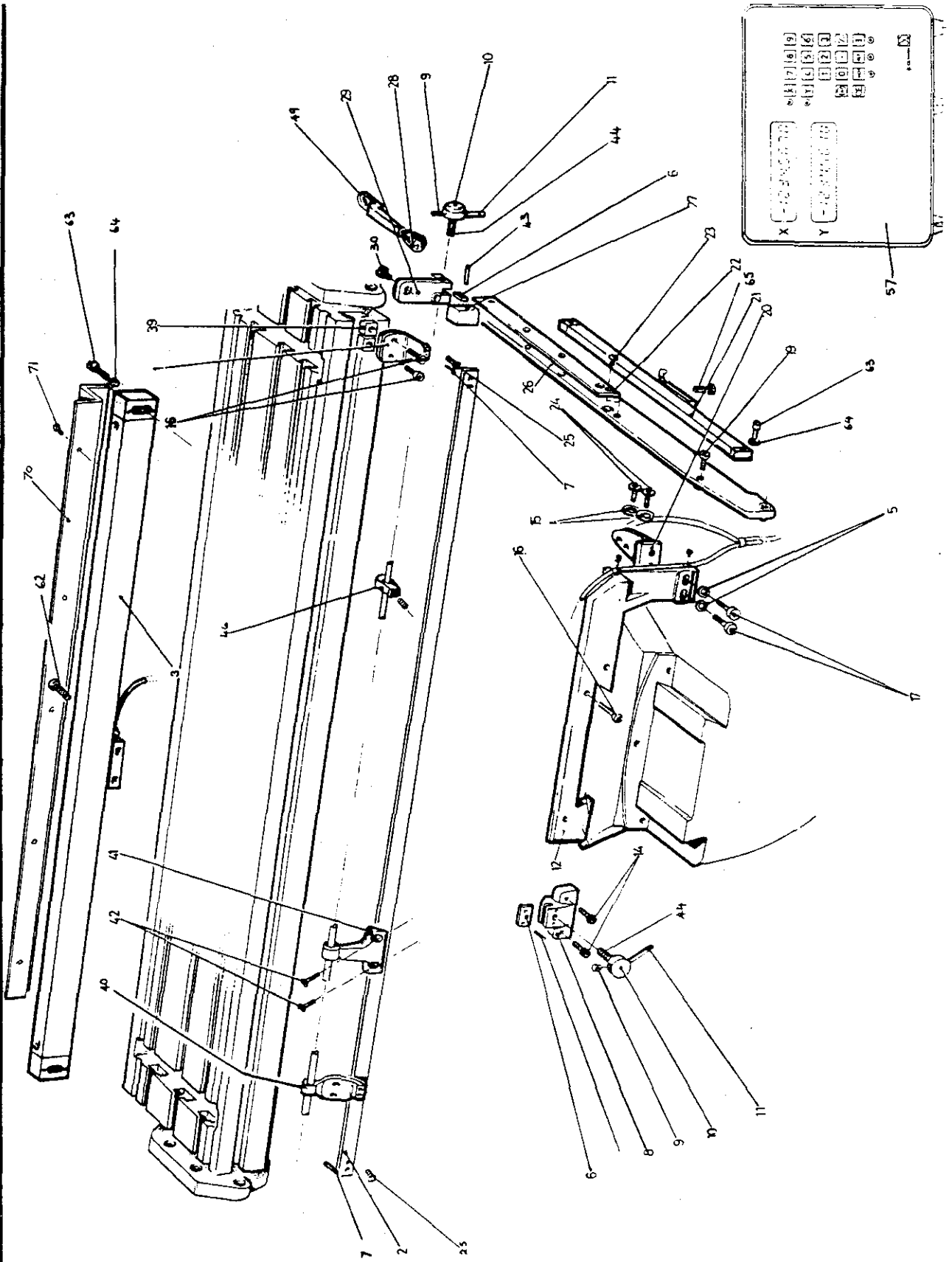

Spare Parts Heidenhain Digital Read-Out VR2 710

ITEM NO	COMP NO	PART NO	DESCRIPTION	QTY
48	8005129	H-129	Saddle knee wiper plate	2
49	8019120	OF 120	Control lever for optics	1
50	8036078/1	DR 78/1/C	Digital readout display mounting bracket	1
51	8036078/2	DR 78/2	Bush for digital readout bracket	1
52	8036078/3	DR 78/3	Lock handle	1
53	8300237	ST 237	Socket set screw	2
54	8300186	ST 186	Cap Screw 3/8" UNC x 3/4"	4
55	8036078/4	DR 78/4/A	Bolt for digital arm	1
56	8036078/5	DR 78/5	Digital readout display mounting bracket	1
57	8036063	DR 63	Reader preset	1
58	8036055	DR55	Wiper holder RH (see page 6-1)	1
59	8036056	DR56	Wiper holder LH (see page 6-1)	1
60	8036057	DR57	Steel shim 010	1
61	8036058	DR58	Steel shim 020	1
62)	8300613	ST613	M4 x 20 mm socket cap screw	6
63)				4
64	8300634	ST634	4 mm washers	2
65	8300612	ST612	4 mm x 16 mm socket cap screw	10
66	8300593	ST593	.002" plastic shim washer	5
67	8300594	ST594	.005" plastic shim washer	6
68	8300595	ST595	0.010" plastic shim	3
69	8300611	ST611	M5 x 12 mm button hd. socket screw	
70	8014745		Readout cover	1
71	8301919	ST 1919	1/4 dia x 3/8 round headscrew	5

Additional Manuals Available

Note:

Any information regarding the Mechanical Feed, T-Head, Optical Measuring System, End Rod System, Digital Optical Measuring Unit, DRO (LS803) and DRO (LS801) can be obtained from Bridgeport Machines in the form of a separate handbook.

REF	AA	WAS	UA
1			

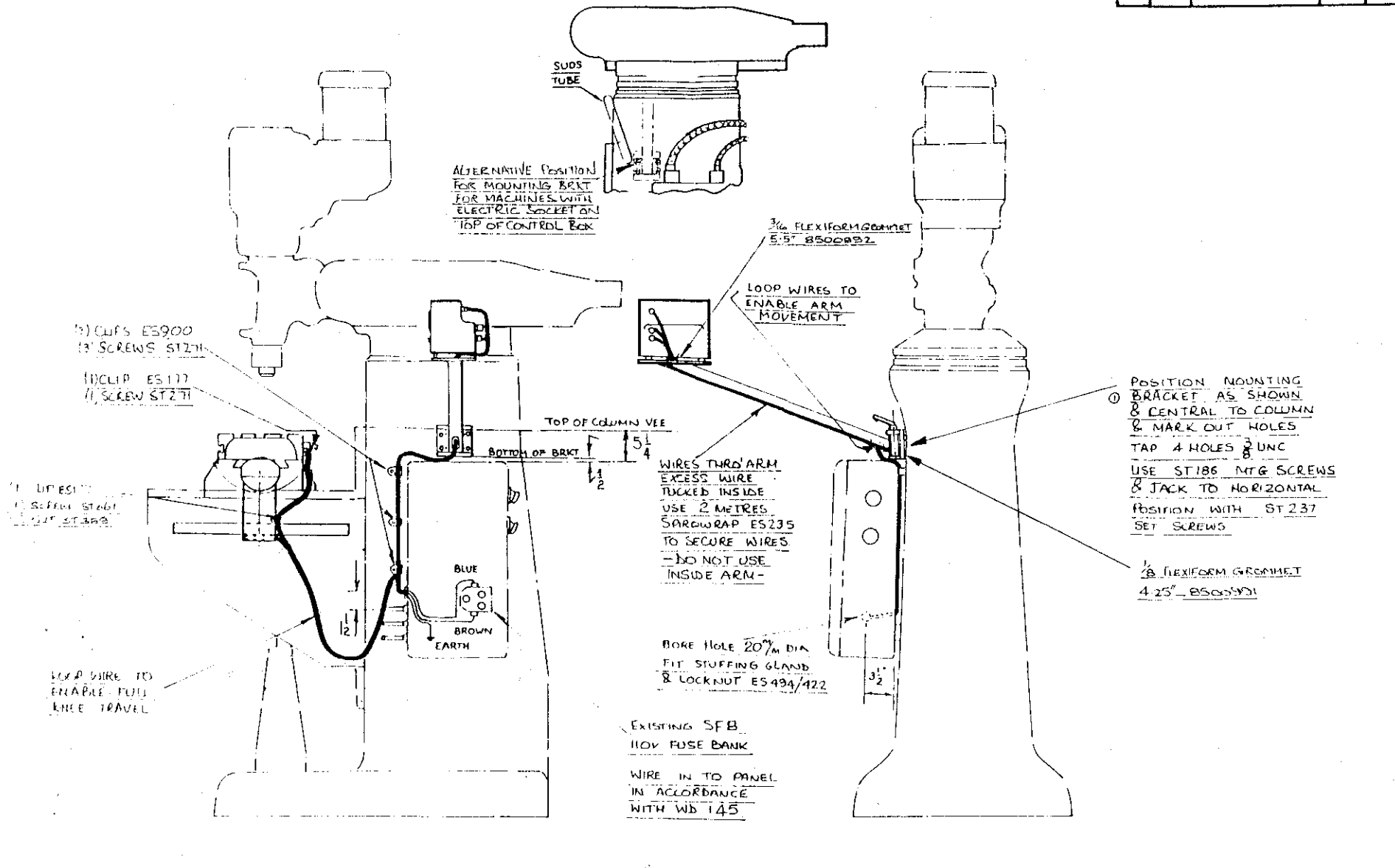

TITLE WIRING LAYOUT FOR DIGITAL READOUT WITH SIDE MOUNTED ARM DR 78

<p>ALL DIMENSIONS IN INCHES UNLESS STATED OTHERWISE</p> <p>Bridgeport</p>	<p>BREAK SHARP CORNERS</p>	<p>TOLERANCES</p> <p>UNLESS OTHERWISE SPECIFIED FRACTIONAL DIMENSIONS MUST BE HELD ± .015" AND DECIMAL DIMENSIONS MUST BE HELD ± .005"</p>	DRAWN	DA	<p>MATERIAL</p>	SCALE	1/8	<p>PART No.</p>	<p>DRAWING No.</p> <p>WD 156/B</p>	<p>ISSUE</p> <p>0</p>	
			CHECKED	B		DATE	22-1-79				1 - M/C FINISH
			<p>WIRE IN TO PANEL IN ACCORDANCE WITH WD 145</p>								G - GROUND FINISH
								SHEET	OF	SHEETS	

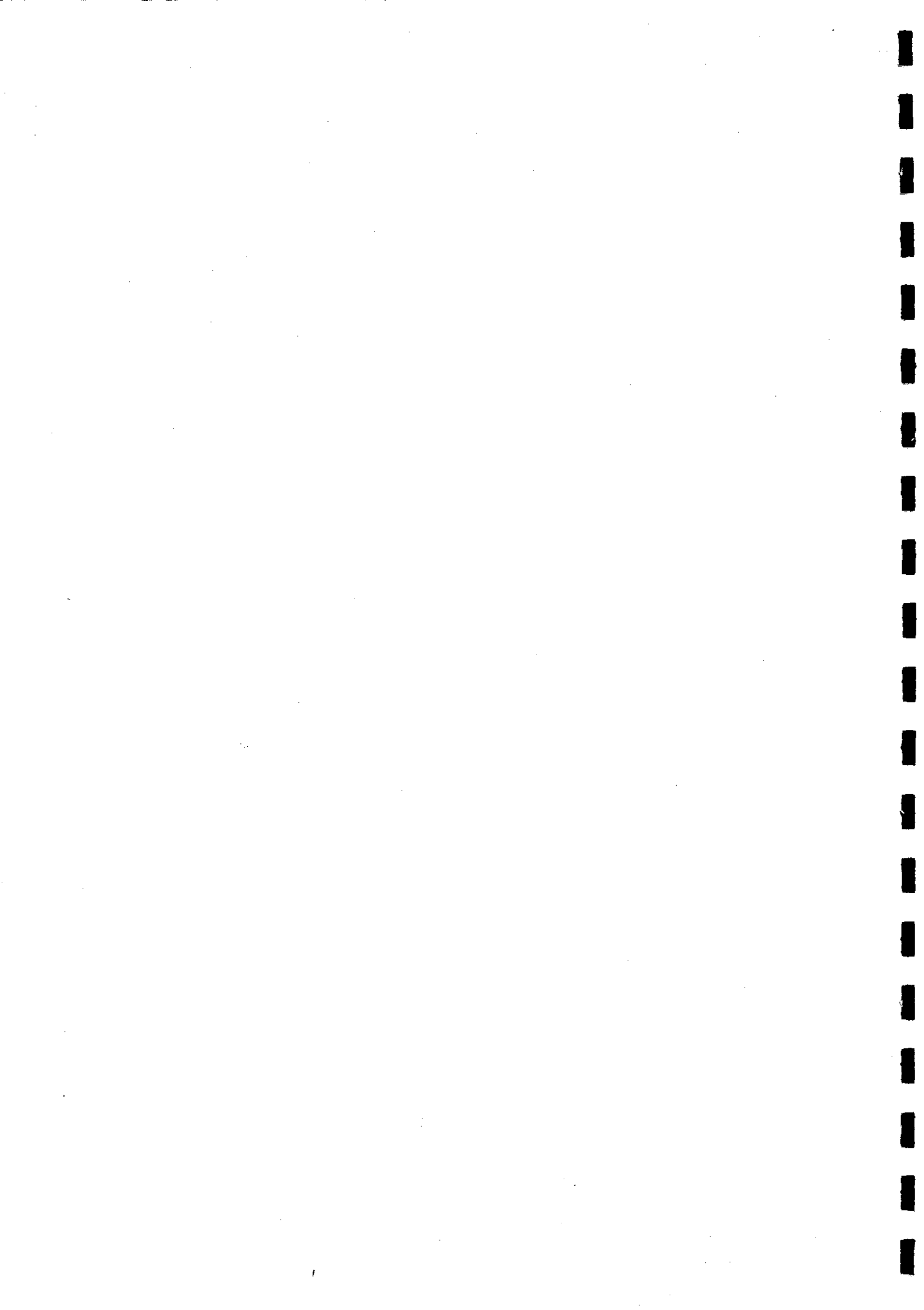

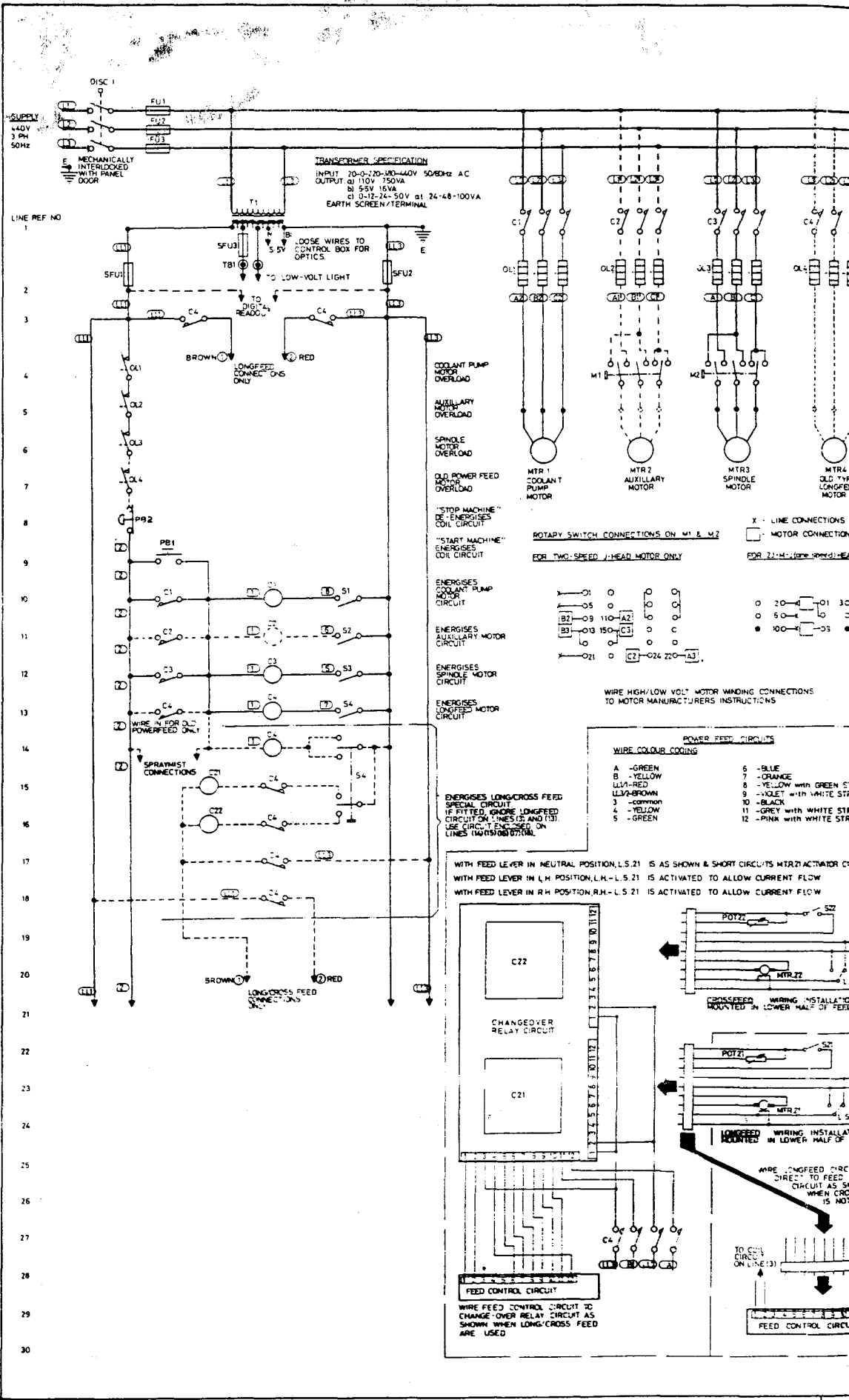

TRANSFORMER SPECIFICATION
 INPUT 20-0-20-30-40V 50/60Hz AC
 OUTPUT (a) 110V 150VA
 (b) 55V 15VA
 (c) 0-12-24-50V at 24-48-100VA
 EARTH SCREEN/TERMINAL

ROTARY SWITCH CONNECTIONS ON M1 & M2
 FOR TWO-SPEED HEAD MOTOR ONLY
 FOR 22-1/2" LONG-SPINDLE HEAD

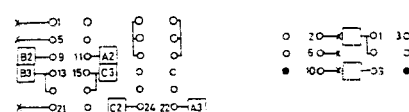

POWER FEED CIRCUITS
WIRE COLOUR CODING

A - GREEN	6 - BLUE
B - YELLOW	7 - ORANGE
UL1 - RED	8 - YELLOW WITH GREEN STR
UL2 - BROWN	9 - VIOLET WITH WHITE STR
3 - common	10 - BLACK
B3 - 013 150 - C31	11 - GREY WITH WHITE STR
4 - YELLOW	12 - PINK WITH WHITE STR
5 - GREEN	

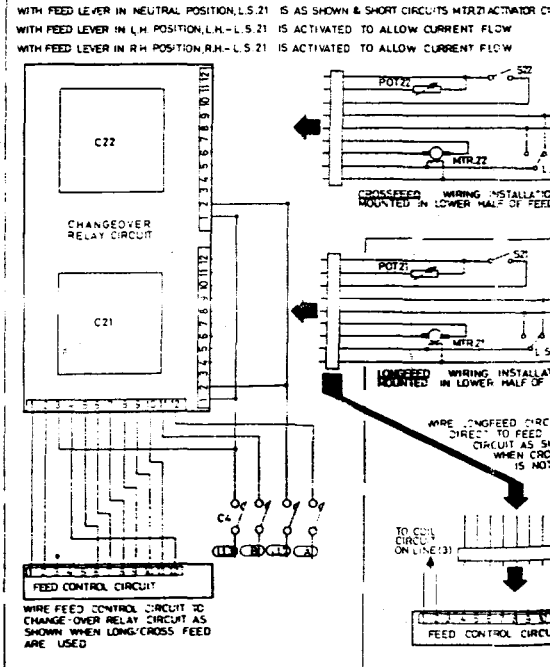

TITLE
 ELECTRICAL WIRING DIAGRAM for BRIDGEPORT MILLING MACHINE fitted with
 STANDARD PANEL 3 LONG/CROSSFEED TYPE

REV	AA	WAS	DATE	INIT
1	1501	PANEL 3 WD 145	11/07/78	DSM
2		PANEL LAYOUT REDESIGNED MTR 2 & B PLUGS & SOCKETS REMOVED, NOW WIRED DIRECT.	7/1-81	RE

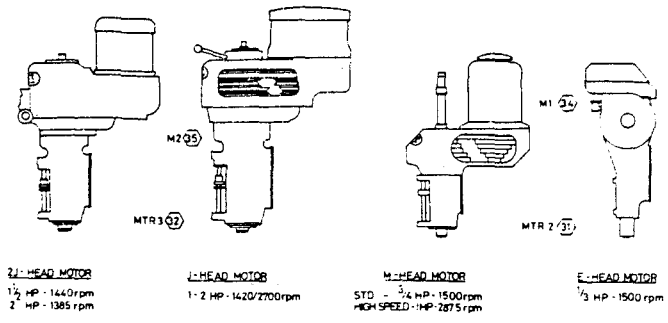

(IF SUPPLIED WITH
AUXILIARY HEAD)

REF	DESCRIPTION	FUNCTION	QTY	UNIT PRICE	OF DEP NO
1	DISC1	MAINS ISOLATOR	1	8500.071	
2	FU#	MAIN FUSE BANK	16A CARTRIDGE	1	8500.036
3	SFU#	110V/240V FUSE BANK	TO SUIT CUSTOMERS REQUIREMENTS	1	1.00
4	T1	TRANSFORMER	COIL CIRCUIT & AUXILIARIES	1	8500.470
5	C1	CONTACTOR	CONTROL OF MTR1 THRU S1	1	8500.070
6	OL1	OVERLOAD - 0.21A	PROTECT MTR1	1	8500.070
7	C2	CONTACTOR	CONTROL OF MTR2 THRU S2	1	8500.070
8	OL2	OVERLOAD - 7.1A	PROTECT MTR2	1	8500.075
9	C3	CONTACTOR	CONTROL OF MTR3 THRU S3	1	8500.070
10	OL3	OVERLOAD - 3.7A	PROTECT MTR3	1	8500.074
11	C4	CONTACTOR	CONTROL OF FEED MTR THRU S4	1	8500.070
12	OL4	OVERLOAD - 1.2A	PROTECT MTR4	1	8500.076
13	S1	TOGGLE SWITCH	ISOLATE MTR1 THRU C1	1	8500.058
14	S2	TOGGLE SWITCH	ISOLATE MTR2 THRU C2	1	8500.058
15	S3	TOGGLE SWITCH	ISOLATE MTR3 THRU C3	1	8500.058
16	S4	TOGGLE SWITCH	ISOLATE LONGFEED MTR THRU C4	1	8500.058
17	S5	TOGGLE SWITCH	ISOLATE LONG/CROSSFEED MTR THRU C4	1	8500.437
18	PB1	START PUSH BUTTON	ENERGISES COIL CIRCUIT	1	8500.058
19	PB2	STOP PUSH BUTTON	DE-ENERGISES COIL CIRCUIT	1	8500.447
20					
21					
22	CB21	FEED CONTROL CIRCUIT INCLUDES CIRCUIT BREAKER		8500.367	
23	CB22	LONG & CROSS FEED CHANGE OVER RELAY CIRCUIT		8500.438	
24	MTR21	LONGFEED MOTOR	D.C. TYPE	8500.001	
25	S21	RAPID TRAVERSE BUTTON - OVERRIDES POT21		8500.358	
26	POT21	FEED POTENTIOMETER	CONTROL OUTPUT OF CONTROL CIRCUIT	8500.357	
27	MTR22	CROSSFEED MOTOR	D.C. TYPE	8500.001	
28	S22	RAPID TRAVERSE BUTTON - OVERRIDES POT22		8500.358	
29	POT22	FEED POTENTIOMETER	CONTROL OUTPUT OF CONTROL CIRCUIT	8500.357	
30	MTR1	COOLANT PUMP MOTOR	3PH A.C. TYPE	8500.010	
31	MTR2	AUXILIARY MOTOR	STD M-HEAD HIGH SPEED M-HEAD E-HEAD	8500.125 8500.141 8500.076	
32	MTR3	SPINDLE MOTOR	2J-HEAD 2HP 2J-HEAD 1 1/2HP J-HEAD 2HP	8500.140 8500.137 8500.130	
33	MTR4	OLD TYPE FEED MOTOR	THRU OL4 - C4 - S4	8500.160	
34	M1/2	ROTCARY SWITCH	J-HEAD 2HP 2" M-HSM HEAD	8500.062 8500.361	
35	M1	TOGGLE SWITCH	E-HEAD	8500.059	
36	LS21	MICRO SWITCH	TWO PER SET LONGFEED	8500.630	
37	LS22	MICRO SWITCH	TWO PER SET CROSSFEED	8500.630	
38		PANEL TYPE 3	ES396 TRANSFORMER BACKPLATE ES406 BACKPLATE	8500.394 8500.405	
			ES987 PANEL BOX - LONG/CROSSFEED TYPE	8500.887	
39		MACHINE CONTROL STATION	ES414	8500.414	
40	TB1	TERMINAL BLOCK	FITTED FOR LOW-VOLT LIGHT	8500.180	

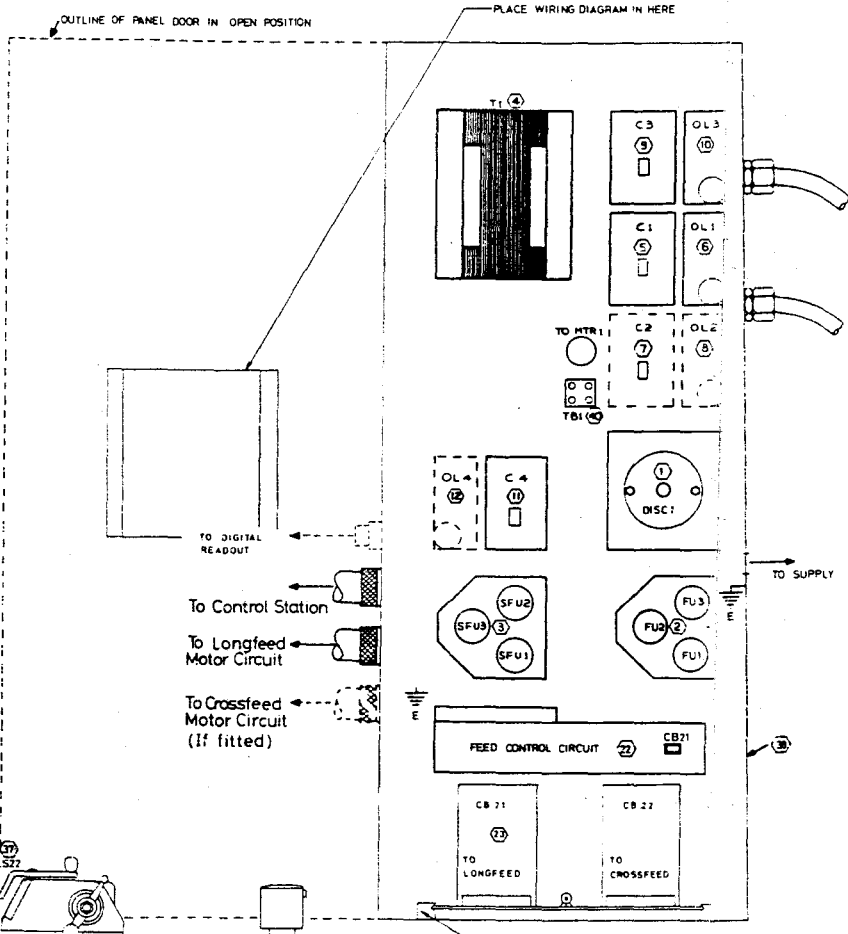

NOTES ON MACHINE WIRING

- FOR MACHINES WIRED FOR A MAINS SUPPLY OTHER THAN 440V 3PH 50HZ CONTACTOR COILS, FUSES & MOTOR SPECIFICATIONS MAY BE ALTERED.
- ALL WIRE MARKINGS INDICATED BY () MAIN/TRANSFORMER LINE WIRES. () COIL CIRCUIT WIRES.
- HIGH VOLTAGE SUPPLY WIRES: ON BACKPLATE SINGLE BLACK 2.5mm RATED 18A TO SOCKETS, SINGLE BLACK 3mm RATED 16A
- 110V COIL CIRCUIT WIRES ON BACKPLATE SINGLE RED 1.0mm RATED 3A CONTROL LOCK WIRE SINGLE RED 0.5mm RATED 5A
- ALLEARTH WIRE SINGLE GREEN/YELLOW 1.0mm RATED 10A.
- ALL LOW VOLT AUXILIARIES RATED 3A EXCEPT D.C. POWER FEED CIRCUIT

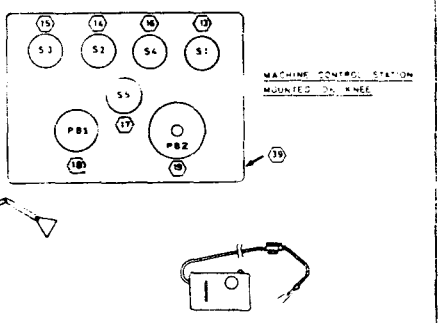
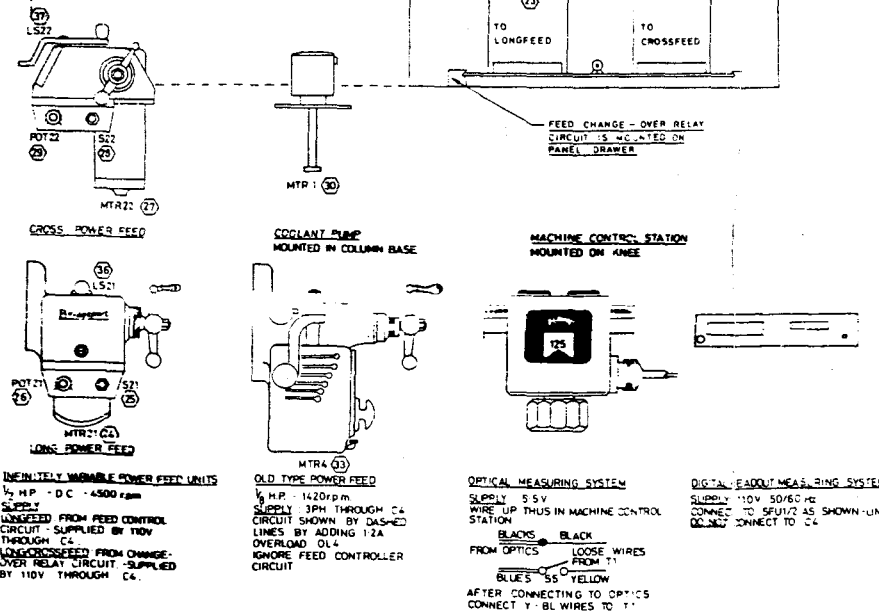

idgeport

DRAWN	D.S. McLachlan	PART No.	DRAWING No.
CHECKED	D.S. McLachlan		WD 153/D
DATE	5-9-79		SHEET 1 OF 1



THE QUEEN'S AWARD FOR
EXPORT ACHIEVEMENT

Bridgeport

SERIES ONE
(models BRJ/BR2J2)
Vertical Milling Machine

**OPERATION AND
MAINTENANCE MANUAL
(INCLUDING SPARE PARTS CATALOGUE)**

PART NO. 1800234