

Code No. 11040077

**QUICK CHANGE TOOLING
AND
ACCESSORIES
FOR
J HEAD
AND
2J VARIABLE SPEED HEAD**

Bridgeport[®]

Bridgeport Machines Division of Textron Inc.

**QUICK CHANGE TOOLING
AND ACCESSORIES
FOR THE J HEAD AND
2J VARIABLE SPEED HEAD**

Code No. 11040077

(Formerly M-122)

MAY 1981

Bridgeport[®]

Bridgeport Machines Division of Textron Inc.

INDEX

#30 QUICK CHANGE TOOLING FOR THE BRIDGEPORT "J" HEAD AND "2J" VARIABLE SPEED HEAD

Model	Description	Page No.
#30	Tooling Package for J and 2J Head	i
#30	Tooling Package for Series I Numerical Control	ii
#30 QC	Bridgeport Spindle with #30 Quick Change	1
#309	Double Angle Collet Chuck - Less Collet	3
#189	Double Angle Collet Chuck - Less Collet	4
	Double Angle Collets	
#300	Collets for 1/32", 1/16" Drill	10
#300	Collet for 3/32" Drill	10
#300	Collets for 1/8" thru 1/4" drill in 1/32" Increments	10
#200	Collets for 1/8" thru 3/8" drill in 1/32" Increments	10
#100	Collets for 1/4" thru 9/16" drill in 1/32" Increments	10
#180	Collets for 1/4" thru 3/4" drill in 1/32" Increments	10
#309	Double Pin Type Floating Holder - Less Collet	7
#209	Double Pin Type Floating Holder - Less Collet	8
#075 HTG	Drill and End Mill Chuck - Less Collet	12
#100 HTG	Drill and End Mill Chuck - Less Collet	13
	End Mill Adapters	
	3/16 End Mill Shank Diameter	21
	3/8 End Mill Shank Diameter	21
	1/2 End Mill Shank Diameter	21
	5/8 End Mill Shank Diameter	21
	3/4 End Mill Shank Diameter	21
	7/8 End Mill Shank Diameter	21
	1" End Mill Shank Diameter	21
#303	Extension Chuck - Less Collet	9
#203	Extension Chuck - Less Collet	9
#103	Extension Chuck - Less Collet	9
#L09	Full Roller Drive Floating Holder - Less Collet	5
	Jacobs Taper Adapters	
#3	Jacobs External Taper	24
#4	Jacobs External Taper	24
#6	Jacobs External Taper	24
	Morse Taper Adapters	
#1	Morse Taper Socket	23
#2	Morse Taper Socket	23
#3	Morse Taper Socket	23
#180NP	Non-Pullout End Mill Collets for 3/8", 1/2", 5/8", & 3/4"	11
075 NPTG	Non-Pullout End Mill Collets 3/8", 1/2", & 5/8"	17
100 NPTG	Non-Pullout End Mill Collets 3/8", 1/2", 5/8", & 3/4"	17
100 NPTG	Non-Pullout End Mill Collets 1"	17
#30 QC	Preset Fixture	31
#30 QC	#30 Quick Change Holder with R-8 Mounting	2
"L"	Reamer Collets 15/64" thru 27/32"	6
	Shell Mill Adapters	
	.500 Pilot Diameter	22
	.750 Pilot Diameter	22
	1.000 Pilot Diameter	22
T.G.	T.G. Collet Specifications	14
	T.G. Collets in 1/64" Increments	

Model	Description	Page No.
#075	T.G. Collets 1/16" thru 3/4"	15
#100	T.G. Collets 3/32" thru 1"	16
	Tap Collets	
#D09	Tap Collets #0 thru 1/4" Hand Tap	30
#F09	Tap Collets 1/4" thru 7/8" Hand Tap	30
#F09	Tap Collets 1/16" thru 1/2" Pipe Tap	30
#G09	Tap Collets 3/4" thru 1-1/4" Pipe tap	30
	Taper Boring Bars	
#30	#30 N.M.T.B. Taper Boring Bar 1/2 to 19/32	25
#30	#30 N.M.T.B. Taper Boring Bar 9/16 to 13/16	25
#30	#30 N.M.T.B. Taper Boring Bar 3/4 to 15/16	25
#30	#30 N.M.T.B. Taper Boring Bar 55/64 to 1-15/64	25
#30	#30 N.M.T.B. Taper Boring Bar 1-11/64 - 1-47/64	25
#30	#30 N.M.T.B. Taper Boring Bar 1-23/32 to 2-17/32	25
#30	#30 N.M.T.B. Taper Boring Bar 2-15/32 to 3-21/32	25
#D09	Tension and Compression "Safe-Drive" Tap Holder - Less Collet	27
#F09	Tension and Compression "Safe-Drive" Tap Holder - Less Collet	29
#D09	Tension Type Tap Holder - Less Collet	26
#F09	Tension Type Tap Holder - Less Collet	28
#37	Tenthset Boring Bars	
	.375 Diameter x 1.50 Length	20
	.375 Diameter x 3.00 Length	20
	.375 Diameter x 5.00 Length	20
#50	Tenthset Boring Bars	
	.500 Diameter x 2.00 Length	20
	.500 Diameter x 4.00 Length	20
	.500 Diameter x 6.50 Length	20
#37	Tenthset Boring Cutters	
	.18 Minimum Bore - .56 Maximum Depth	20
	.18 Minimum Bore - .94 Maximum Depth	20
	.25 Minimum Bore - .75 Maximum Depth	20
	.25 Minimum Bore - 1.25 Maximum Depth	20
	.31 Minimum Bore - .94 Maximum Depth	20
	.31 Minimum Bore - 1.56 Maximum Depth	20
	.37 Minimum Bore - 1.12 Maximum Depth	20
	.37 Minimum Bore - 1.88 Maximum Depth	20
#50	Tenthset Boring Cutters	
	.25 Minimum Bore - .75 Maximum Depth	20
	.25 Minimum Bore - 1.25 Maximum Depth	20
	.31 Minimum Bore - .94 Maximum Depth	20
	.31 Minimum Bore - 1.56 Maximum Depth	20
	.37 Minimum Bore - 1.12 Maximum Depth	20
	.37 Minimum Bore - 1.88 Maximum Depth	20
	.44 Minimum Bore - 1.31 Maximum Depth	20
	.44 Minimum Bore - 2.18 Maximum Depth	20
	.50 Minimum Bore - 1.50 Maximum Depth	20
	.50 Minimum Bore - 2.50 Maximum Depth	20
#37	Tenthset Boring Head and Adapter	18
#50	Tenthset Boring Head and Adapter	19

**BRIDGEPORT RECOMMENDED TOOLING PACKAGE FOR
STANDARD MACHINE WITH
"J" HEAD AND "2J" VARIABLE SPEED HEAD
(PACKAGE CODE #1-57-0003)**

QUAN	BRIDGEPORT NO.	DESCRIPTION
1	1-57-0005	#309 Collet Chuck #30 MMT
1	1-57-0053	#300 Collet 1/8" I. D.
1	1-57-0054	#300 Collet 5/32" I. D.
1	1-57-0055	#300 Collet 3/16" I. D.
1	1-57-0056	#300 Collet 7/32" I. D.
1	1-57-0057	#300 Collet 1/4" I. D.
1	1-57-0045	#303 Tool Extension Chuck (Uses #300 Collets Above)
1	1-57-0006	#189 Collet Chuck #30 MMT
1	1-57-0120	#180 Collet 1/4" I. D.
1	1-57-0122	#180 Collet 5/16" I. D.
1	1-57-0124	#180 Collet 3/8" I. D.
1	1-57-0126	#180 Collet 7/16" I. D.
1	1-57-0128	#180 Collet 1/2" I. D.
1	1-57-0130	#180 Collet 9/16" I. D.
1	1-57-0132	#180 Collets 5/8" I. D.
1	1-57-0134	#180 Collets 11/16" I. D.
1	1-57-0136	#180 Collets 3/4" I. D.
		Non-Pullout End Mill Collets
1	1-57-0150	3/8"
1	1-57-0151	1/2"
1	1-57-0152	5/8"
1	1-57-0153	3/4"
1	1-57-0346	1" End Mill Adapter
1	1-57-0350	1/2" Pilot Shell Mill Adapter
1	1-57-0548	Open End Wrench 1 1/2"
1	1-57-0549	Open End Wrench 11/16"
<p>Note: 1. To order complete package, use Bridgeport #1-57-0003. 2. For additional items, order above package plus any additional items required.</p>		

**BRIDGEPORT RECOMMENDED #30 QUICK CHANGE TOOLING PACKAGE
FOR BRIDGEPORT SERIES I N/C MACHINE
(PACKAGE CODE # 1-57-0550)**

Consists of a Bridgeport #30 Quick Change basic tooling package composed of collets as listed, corresponding tool holders, a locking fixture for assembly of cutters in the holders, and wrenches.

Quantity	Bridgeport Code No.	Description
6	#1-57-0006	Drill and end mill chuck Range: 1/4 to 3/4
1	#1-57-0120	Collet 1/4"
1	#1-57-0122	Collet 5/16"
5	#1-57-0124	Collet 3/8"
1	#1-57-0126	Collet 7/16"
2	#1-57-0128	Collet 1/2"
1	#1-57-0130	Collet 9/16"
1	#1-57-0132	Collet 5/8"
1	#1-57-0134	Collet 11/16"
1	#1-57-0136	Collet 3/4"
1	#1-57-0150	Collet 3/8" (non pullout)
1	#1-57-0151	Collet 1/2" (non pullout)
1	#1-57-0152	Collet 5/8" (non pullout)
1	#1-57-0153	Collet 3/4" (non pullout)
2	#1-57-0005	Drill Chuck Range: 1/8 to 1/4
1	#1-57-0053	Collet 1/8"
1	#1-57-0054	Collet 5/32"
1	#1-57-0055	Collet 3/16"
1	#1-57-0056	Collet 7/32"
1	#1-57-0057	Collet 1/4"
1	#1-57-0548	Open End Wrench 1-1/2"
1	#1-57-0549	Open End Wrench 11/16"
1	#1-57-2335	Locking Fixture for Chucks

NOTE: to order complete package, use Bridgeport Code #1-57-0550.

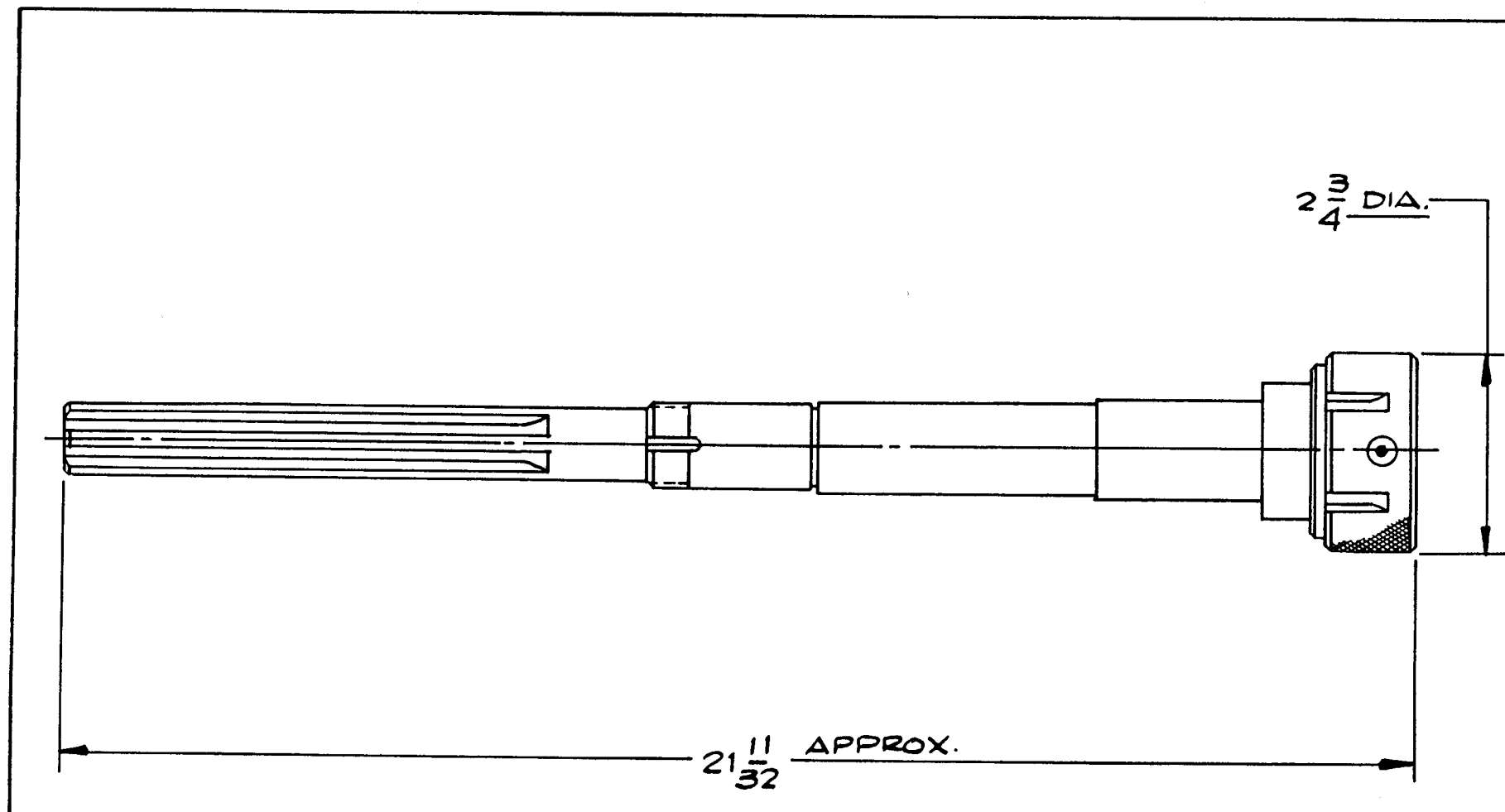

BRIDGEPORT #1-57-0000

(Includes Wrench
& Drive Keys)

**#30 QUICK CHANGE SPINDLE FOR BRIDGEPORT
J HEAD & 2J VARIABLE SPEED HEAD**

#30 M.M.T. SOCKET
3.500 T.P.F.

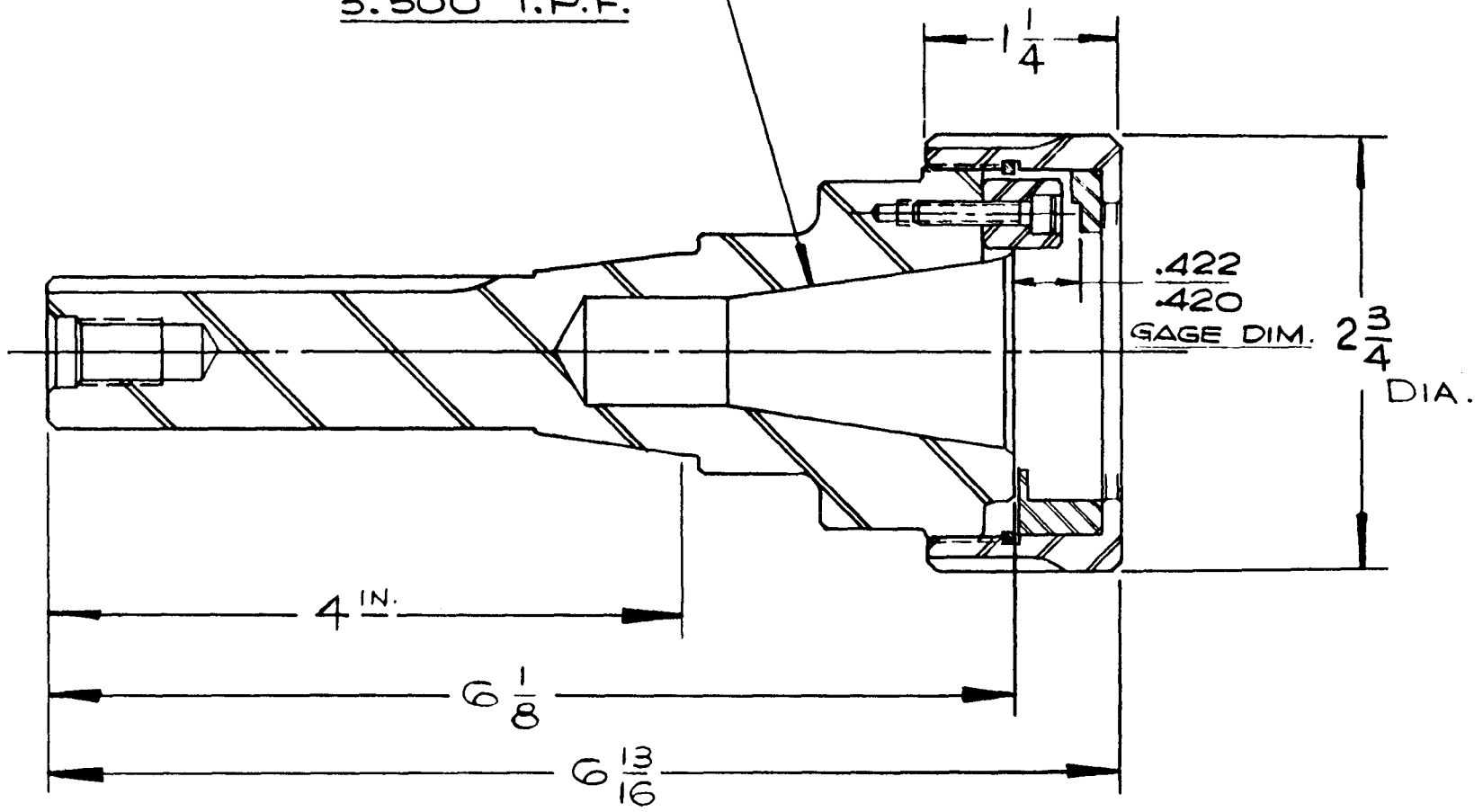

.422
.420
GAGE DIM. 2 ³/₄ DIA.

2

BRIDGEPORT #1-57-0001

#30 QUICK-CHANGE HOLDER
W/#R-8 MTG.

1/4 MAX. DIA.
THRU SHANK

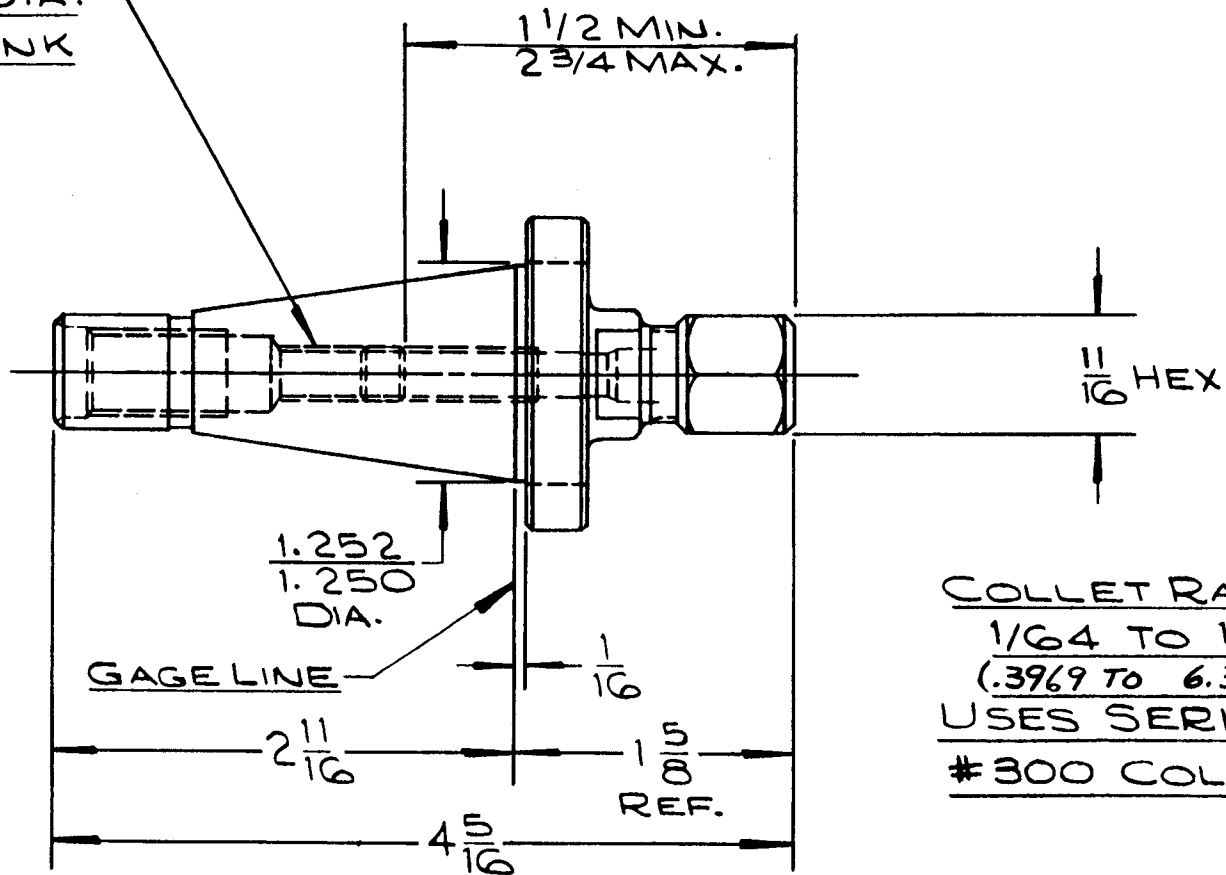

COLLET RANGE
1/64 TO 1/4 INS.
(.3969 TO 6.35 MM.)
USES SERIES
#300 COLLETS

BRIDGEPORT #1-57-0005

#309 DOUBLE ANGLE COLLET CHUCK
W/ #30 M.M.T. MTG.

3/4 MAX. DIA.
THRU SHANK

$1\frac{15}{16}$ MIN.
 $2\frac{1}{4}$ MAX.

$1\frac{1}{2}$ HEX

COLLET RANGE
 $\frac{1}{4}$ TO $\frac{3}{4}$ INS.
(6.35 TO 19.05 MM)

$\frac{1.252}{1.250}$
DIA.

GAGE LINE

$\frac{1}{16}$

$2\frac{11}{16}$

$2\frac{1}{16}$
REF.

$4\frac{3}{4}$

USES SERIES
#180 COLLETS

BRIDGEPORT #1-57-0006

#189 DOUBLE ANGLE COLLET CHUCK
W/ #30 M.M.T. MTG.

COLLET RANGE :
15/64 TO 27/32 REAMER
(5.9531 TO 21.4313 MM)

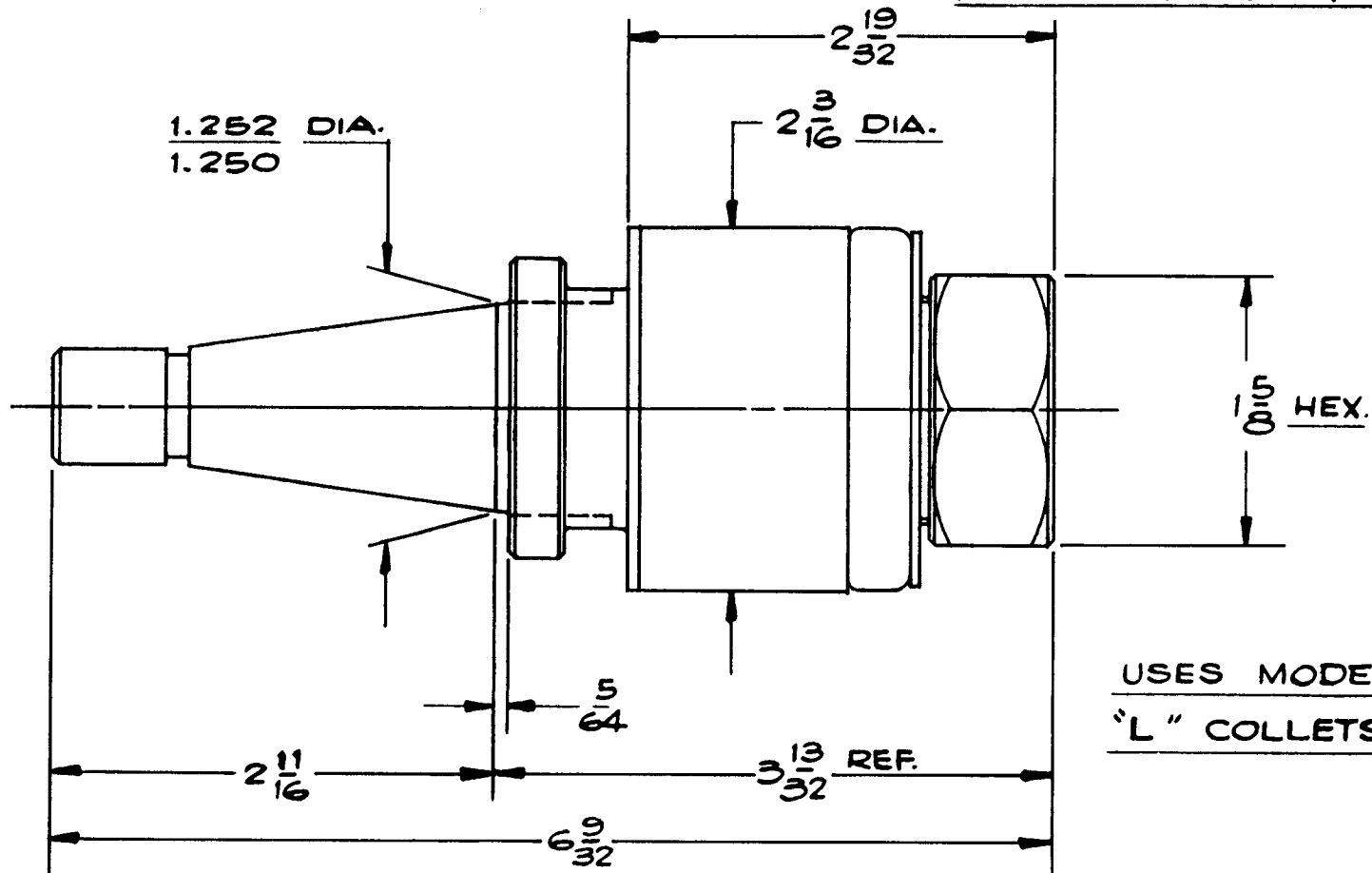

USES MODEL
"L" COLLETS

BRIDGEPORT #1-57-0010

L-09 FULL ROLLER DRIVE FLOATING
HOLDER w/ #30 N.M.T.B. MTG.

"L" REAMER COLLETS

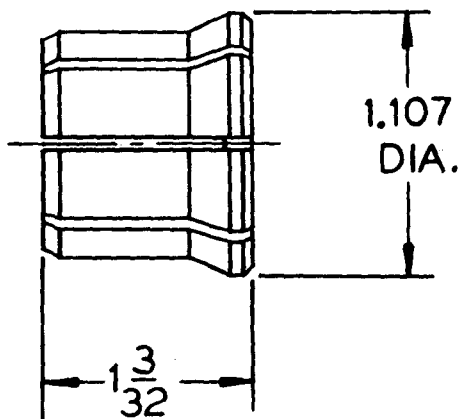

REAMER SIZE	BRIDGEPORT NUMBER	COLLET SIZE	
		INCH	MM.
15/64 & 1/4	1-57-0011	.241	6.1214
17/64 & 9/32	1-57-0012	.250	6.35
19/64 to 11/32	1-57-0013	.281	7.1374
23/64 to 13/32	1-57-0014	.312	7.9248
27/64 to 15/32	1-57-0015	.375	9.525
31/64 to 19/32	1-57-0016	.437	11.0998
5/8 to 23/32	1-57-0017	.562	14.2748
3/4 to 27/32	1-57-0018	.625	15.8750

NOTE: HOLDER HAS BOTH PARALLEL & ANGULAR FLOAT

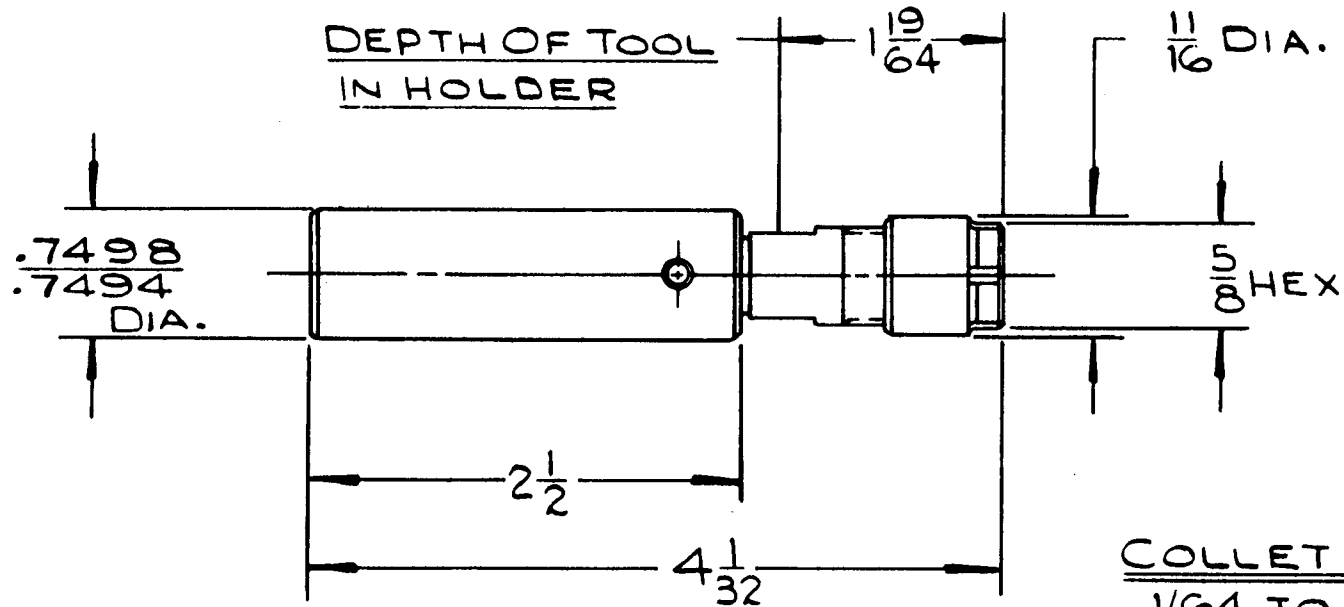

COLLET RANGE:
 $\frac{1}{64}$ TO $\frac{1}{4}$ INS.
(.3969 TO 6.35 MM)
USES SERIES
#300 COLLETS

BRIDGEPORT #1-57-0040

#309 DOUBLE PIN TYPE FLOATING HOLDER
WITH $\frac{3}{4}$ DIA. x $2\frac{1}{2}$ LG. STRAIGHT SHANK

NOTE: HOLDER HAS BOTH PARALLEL & ANGULAR FLOAT

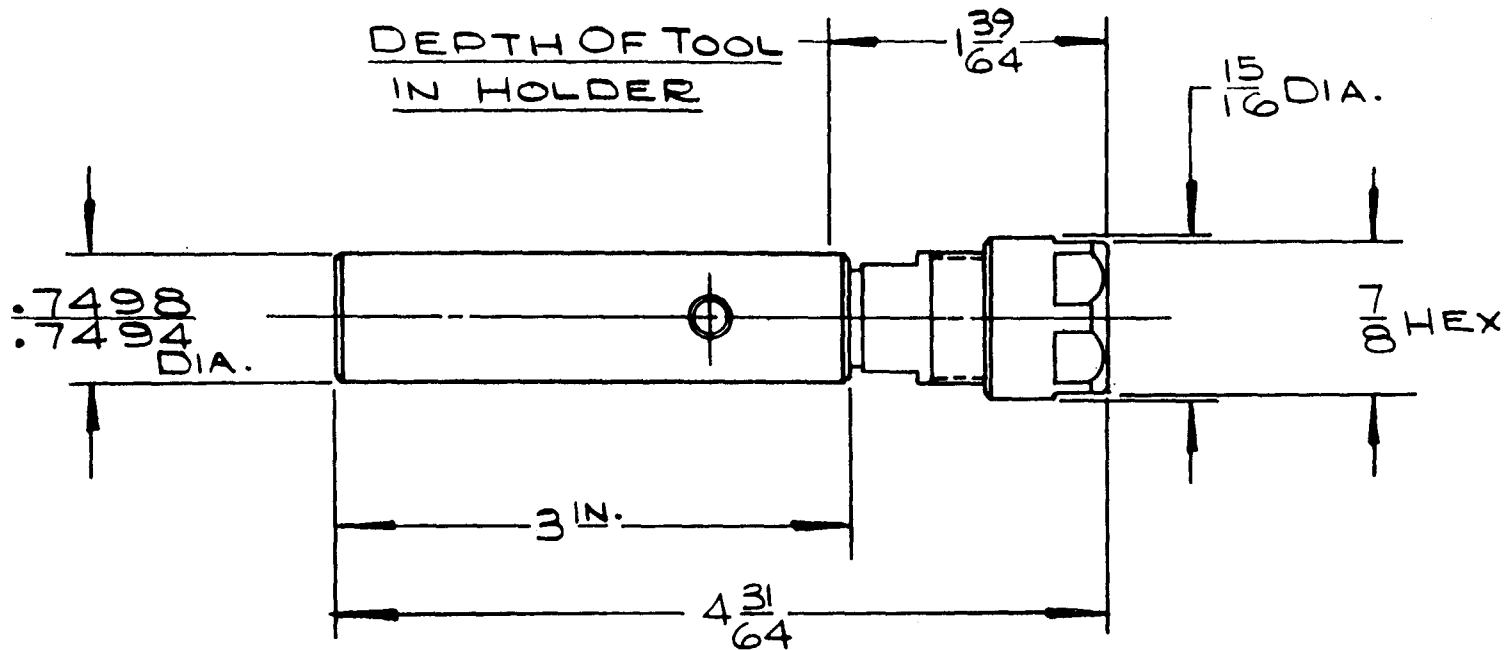

COLLET RANGE:
 $\frac{1}{64}$ TO $\frac{3}{8}$ INS.
(.3969 TO 9.525 MM)
USES SERIES
#200 COLLETS

BRIDGEPORT #1-57-0041

209 DOUBLE PIN TYPE FLOATING HOLDER
WITH $\frac{3}{4}$ DIA. X 3 IN. LG. STRAIGHT SHANK

'03 TOOL EXTENSIONS

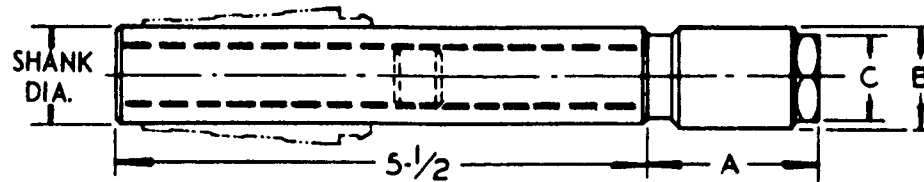

CHUCK CAPACITY		SHANK DIA.	A	B	C	COLLET SERIES	BRIDGEPORT NO.
INCH	MM						
.013-1/4	.3302-6.35	1/2	1-5/16	.560	1/2 HEX	300	1-57-0045
1/8-3/8	3.175-9.525	3/4	1-5/8	13/16	11/16 HEX	200	1-57-0046
1/8-9/16	3.175-14.2875	1 inch	1-13/16	1-1/16	7/8 HEX	100	1-57-0047

NOTE: MAX. DIA. THRU SHANK, IS SAME AS MAX. CHUCK CAPACITY.

6

DOUBLE ANGLE COLLETS

ALL COLLETS HAVE 1/32" COLLAPSE SO THAT A 300 COLLET 3/64" CAPACITY WILL GRIP SECURELY AND ACCURATELY A DRILL MEASURING .013 - #80.

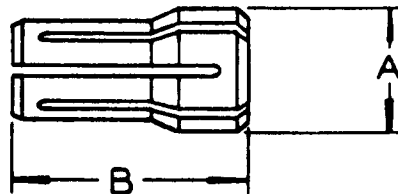

COLLET SERIES	COLLET RANGE		A	B
	INCH	MM		
300	.013-1/4	.3302-6.35	.375	1 in.
200	1/8-3/8	3.175-9.525	.539	1-3/16
100	1/4-9/16	6.35-14.2875	.769	1-7/16
180	1/4-3/4	6.35-19.05	1.035	1-5/8

* See following page for collet ordering numbers.

DOUBLE ANGLE COLLETS

300 COLLETS		
BRIDGEPORT NO.	SIZE	
	INCH	MM
1-57-0050	1/32	.7938
1-57-0051	1/16	1.5875
1-57-0052	3/32	2.3813
1-57-0053	1/8	3.1750
1-57-0054	5/32	3.9688
1-57-0055	3/16	4.7625
1-57-0056	7/32	5.5563
1-57-0057	1/4	6.35
200 COLLETS		
1-57-0070	1/8	3.1750
1-57-0071	5/32	3.9688
1-57-0072	3/16	4.7625
1-57-0073	7/32	5.5563
1-57-0074	1/4	6.35
1-57-0075	9/32	7.1438
1-57-0076	5/16	7.9375
1-57-0077	11/32	8.7313
1-57-0078	3/8	9.525

100 COLLETS		
BRIDGEPORT NO.	SIZE	
	INCH	MM
1-57-0090	1/4	6.35
1-57-0091	9/32	7.1438
1-57-0092	5/16	7.9375
1-57-0093	11/32	8.7313
1-57-0094	3/8	9.525
1-57-0095	13/32	10.3188
1-57-0096	7/16	11.1125
1-57-0097	15/32	11.9063
1-57-0098	1/2	12.70
1-57-0099	17/32	13.4938
1-57-0100	9/16	14.2875

180 COLLETS		
BRIDGEPORT NO.	SIZE	
	INCH	MM
1-57-0120	1/4	6.35
1-57-0121	9/32	7.1438
1-57-0122	5/16	7.9375
1-57-0123	11/32	8.7313
1-57-0124	3/8	9.525
1-57-0125	13/32	10.3188
1-57-0126	7/16	11.1125
1-57-0127	15/32	11.9063
1-57-0128	1/2	12.70
1-57-0129	17/32	13.4938
1-57-0130	9/16	14.2875
1-57-0131	19/32	15.0813
1-57-0132	5/8	15.875
1-57-0133	21/32	16.6688
1-57-0134	11/16	17.4625
1-57-0135	23/32	18.2563
1-57-0136	3/4	19.05

**NON-PULLOUT END MILL COLLETS
FOR USE WITH #189 CHUCK**

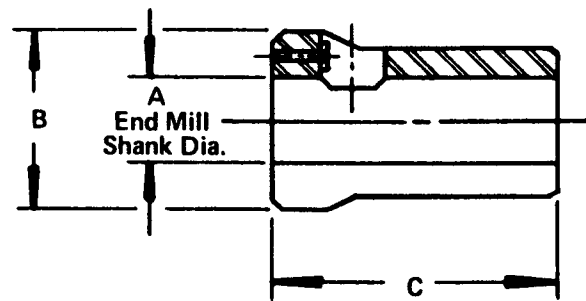

MODEL NO.	USED WITH	A		B	C	BRIDGEPORT NO.
		INCH	MM			
180 N.P.	3/4 CAP. CHUCK	3/8	9.525	1.035	1-5/8	1-57-0150
180 N.P.	3/4 CAP. CHUCK	1/2	12.70	1.035	1-5/8	1-57-0151
180 N.P.	3/4 CAP. CHUCK	5/8	15.875	1.035	1-5/8	1-57-0152
180 N.P.	3/4 CAP. CHUCK	3/4	19.05	1.035	1-5/8	1-57-0153

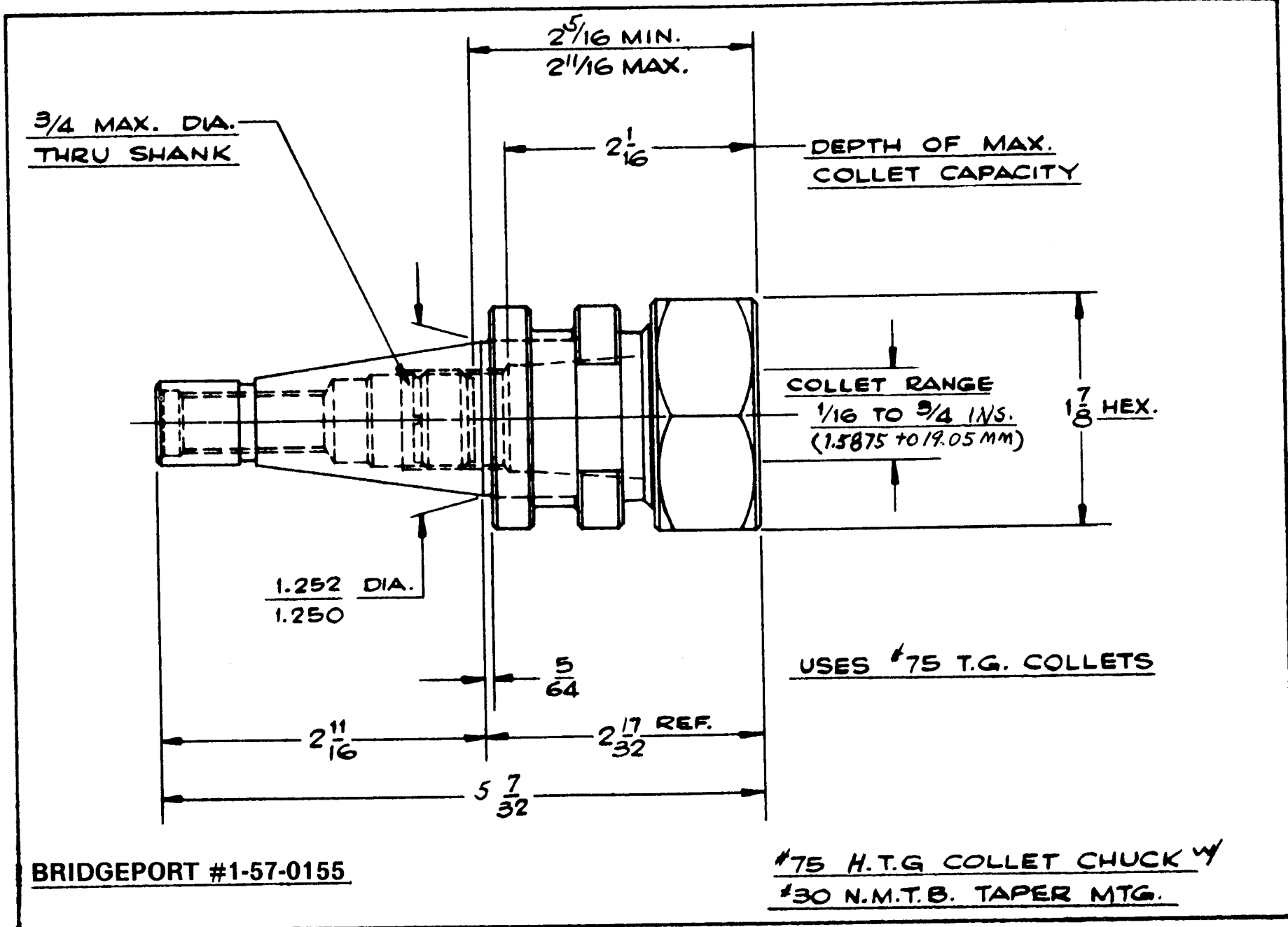

BRIDGEPORT #1-57-0155

#75 H.T.G COLLET CHUCK
#30 N.M.T.B. TAPER MTG.

3/4 MAX. DIA.
THRU SHANK

$2\frac{15}{16}$ MIN.
 $3\frac{15}{16}$ MAX.

$2\frac{15}{16}$
DEPTH OF MAX.
COLLET CAPACITY

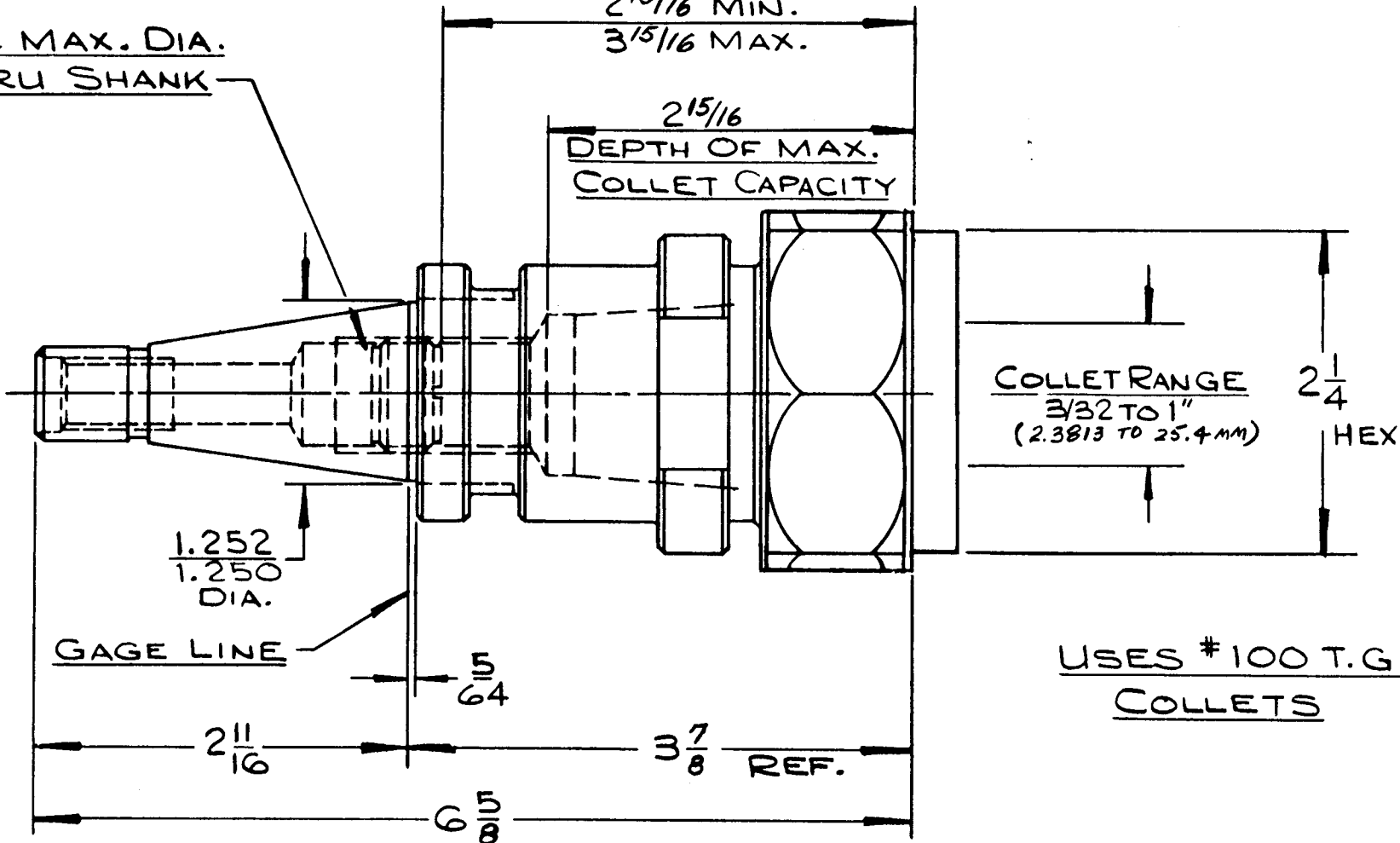

COLLET RANGE $2\frac{1}{4}$
 $\frac{3}{32}$ TO 1"
(2.3813 TO 25.4 MM)
HEX

USES #100 T.G.
COLLETS

BRIDGEPORT #1-57-0156

#100 H.T.G. DRILL & END MILL CHUCK
W/ # 30 M.M.T. MTG.

T.G. COLLETS

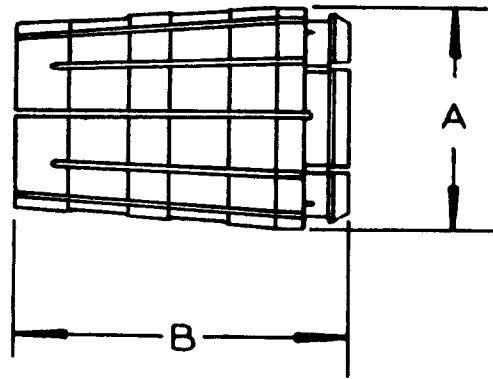

COLLET RANGE		MODEL	A	B
INCH	MM			
1/16 to 3/4	1.5875-19.05	075	1.063	1-27/32
3/32 to 1	2.3813-25.4	100	1.379	2-3/8

See next page for collet ordering numbers.

075 T.G. COLLETS

BRIDGEPORT NO.	SIZE	
	INCH	MM
1-57-0160	1/16	1.5875
1-57-0161	5/64	1.9844
1-57-0162	3/32	2.3813
1-57-0163	7/64	2.7781
1-57-0164	1/8	3.1750
1-57-0165	9/64	3.5719
1-57-0166	5/32	3.9688
1-57-0167	11/64	4.3656
1-57-0168	3/16	4.7625
1-57-0169	13/64	5.1594
1-57-0170	7/32	5.5563
1-57-0171	15/64	5.9531
1-57-0172	1/4	6.35
1-57-0173	17/64	6.7469
1-57-0174	9/32	7.1438

BRIDGEPORT NO.	SIZE	
	INCH	MM
1-57-0175	19/64	7.5406
1-57-0176	5/16	7.9375
1-57-0177	21/64	8.3344
1-57-0178	11/32	8.7313
1-57-0179	23/64	9.1281
1-57-0180	3/8	9.525
1-57-0181	25/64	9.9219
1-57-0182	13/32	10.3188
1-57-0183	27/64	10.7156
1-57-0184	7/16	11.1125
1-57-0185	29/64	11.5094
1-57-0186	15/32	11.9063
1-57-0187	31/64	12.3031
1-57-0188	1/2	12.70
1-57-0189	33/64	13.0969

BRIDGEPORT NO.	SIZE	
	INCH	MM
1-57-0190	17/32	13.4938
1-57-0191	35/64	13.8906
1-57-0192	9/16	14.2875
1-57-0193	37/64	14.6844
1-57-0194	19/32	15.0813
1-57-0195	39/64	15.4781
1-57-0196	5/8	15.875
1-57-0197	41/64	16.2719
1-57-0198	21/32	16.6688
1-57-0199	43/64	17.0656
1-57-0200	11/16	17.4625
1-57-0201	45/64	17.8594
1-57-0202	23/32	18.2563
1-57-0203	47/64	18.6531
1-57-0204	3/4	19.05

100 T.G. COLLETS

BRIDGEPORT NO.	SIZE		BRIDGEPORT NO.	SIZE		BRIDGEPORT NO.	SIZE	
	INCH	MM		INCH	MM		INCH	MM
1-57-0220	3/32	2.3813	1-57-0240	13/32	10.3188	1-57-0260	23/32	18.2563
1-57-0221	7/64	2.7781	1-57-0241	27/64	10.7156	1-57-0261	47/64	18.6531
1-57-0222	1/8	3.175	1-57-0242	7/16	11.1125	1-57-0262	3/4	19.05
1-57-0223	9/64	3.5719	1-57-0243	29/64	11.5094	1-57-0263	49/64	19.4469
1-57-0224	5/32	3.9688	1-57-0244	15/32	11.9063	1-57-0264	25/32	19.8438
1-57-0225	11/64	4.3656	1-57-0245	31/64	12.3031	1-57-0265	51/64	20.2406
1-57-0226	3/16	4.7625	1-57-0246	1/2	12.70	1-57-0266	13/16	20.6375
1-57-0227	13/64	5.1594	1-57-0247	33/64	13.0969	1-57-0267	53/64	21.0344
1-57-0228	7/32	5.5563	1-57-0248	17/32	13.4938	1-57-0268	27/32	21.4313
1-57-0229	15/64	5.9531	1-57-0249	35/64	13.8906	1-57-0269	55/64	21.8281
1-57-0230	1/4	6.35	1-57-0250	9/16	14.2875	1-57-0270	7/8	22.225
1-57-0231	17/64	6.7469	1-57-0251	37/64	14.6844	1-57-0271	57/64	22.6219
1-57-0232	9/32	7.1438	1-57-0252	19/32	15.0813	1-57-0272	29/32	23.0188
1-57-0233	19/64	7.5406	1-57-0253	39/64	15.4781	1-57-0273	59/64	23.4156
1-57-0234	5/16	7.9375	1-57-0254	5/8	15.875	1-57-0274	15/16	23.8125
1-57-0235	21/64	8.3344	1-57-0255	41/64	16.2719	1-57-0275	61/64	24.2094
1-57-0236	11/32	8.7313	1-57-0256	21/32	16.6688	1-57-0276	31/32	24.6063
1-57-0237	23/64	9.1281	1-57-0257	43/64	17.0656	1-57-0277	63/64	25.0031
1-57-0238	3/8	9.525	1-57-0258	11/16	17.4625	1-57-0278	1"	25.40
1-57-0239	25/64	9.9219	1-57-0259	45/64	17.8594			

**NON-PULLOUT END MILL COLLETS
FOR USE WITH T.G. & H.T.G. CHUCKS**

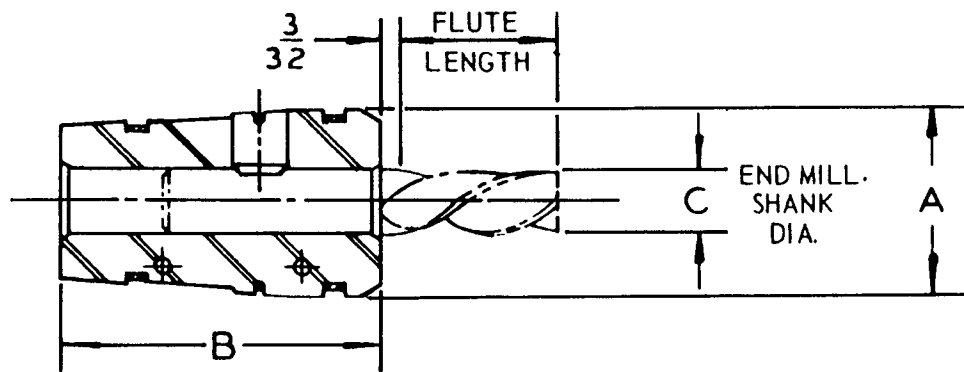
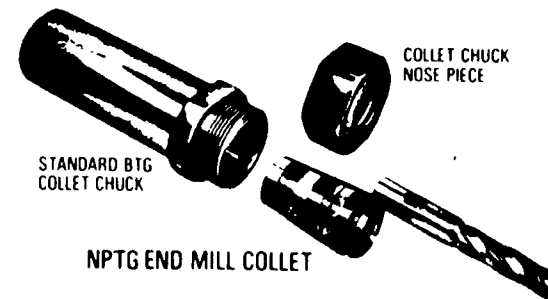

MODEL NO.	USED WITH	A	B	C		BRIDGEPORT NO.
				INCH	MM	
075 N.P.T.G.	3/4" Cap. Chuck	1.063	1-27/32	3/8	9.525	1-57-0300
075 N.P.T.G.	3/4" Cap. Chuck	1.063	1-27/32	1/2	12.70	1-57-0301
075 N.P.T.G.	3/4" Cap. Chuck	1.063	1-27/32	5/8	15.875	1-57-0302
100 N.P.T.G.	1" Cap. Chuck	1.379	2-3/8	3/8	9.525	1-57-0305
100 N.P.T.G.	1" Cap. Chuck	1.379	2-3/8	1/2	12.70	1-57-0306
100 N.P.T.G.	1" Cap. Chuck	1.379	2-3/8	5/8	15.875	1-57-0307
100 N.P.T.G.	1" Cap. Chuck	1.379	2-3/8	3/4	19.05	1-57-0308
100 N.P.T.G.	1" Cap. Chuck	1.379	2-3/8	1"	25.40	1-57-0309

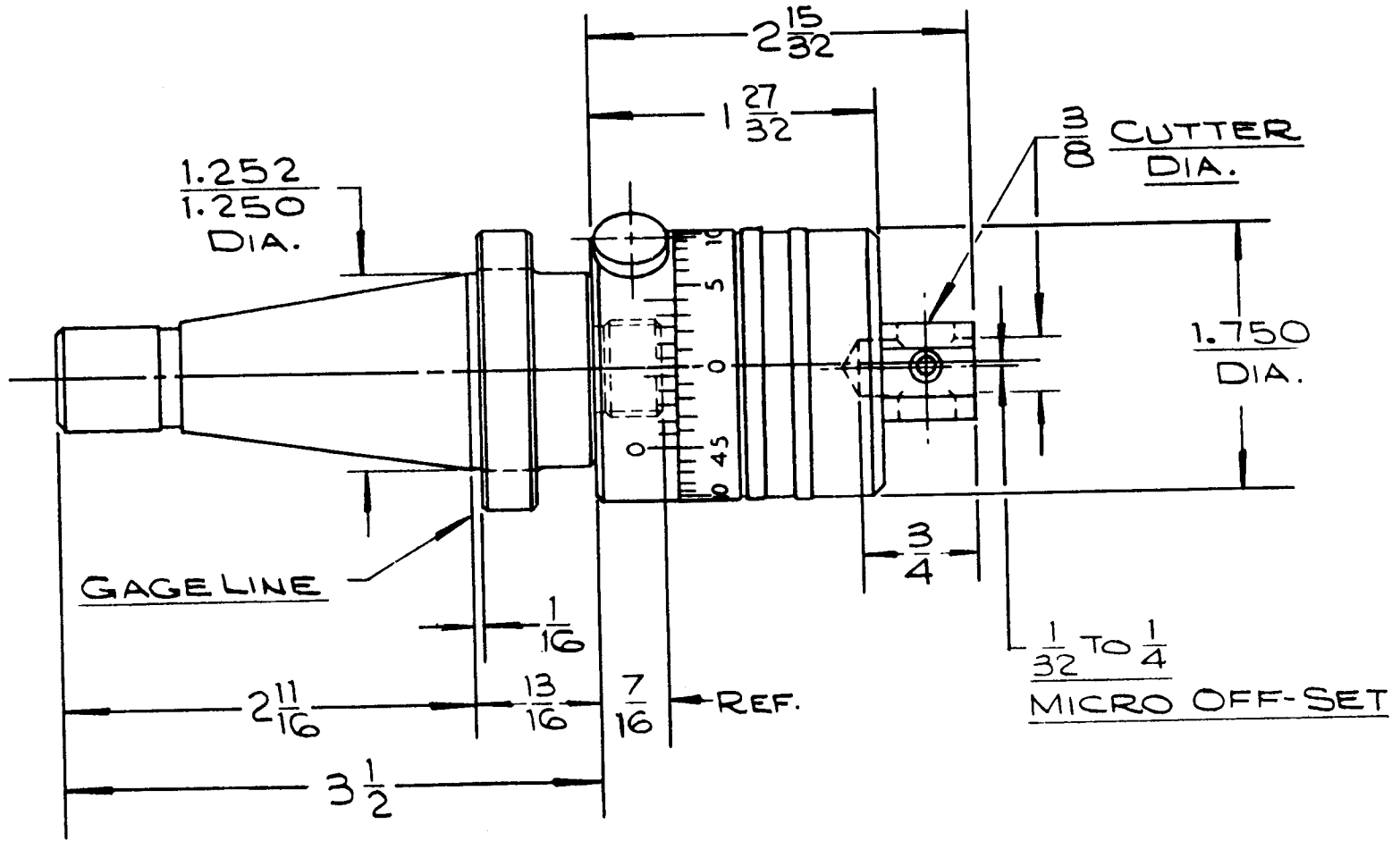

BRIDGEPORT #1-57-0310

#37 TENTH SET BORING HEAD ADAPTER
W/ #30 M.M.T. MTG.

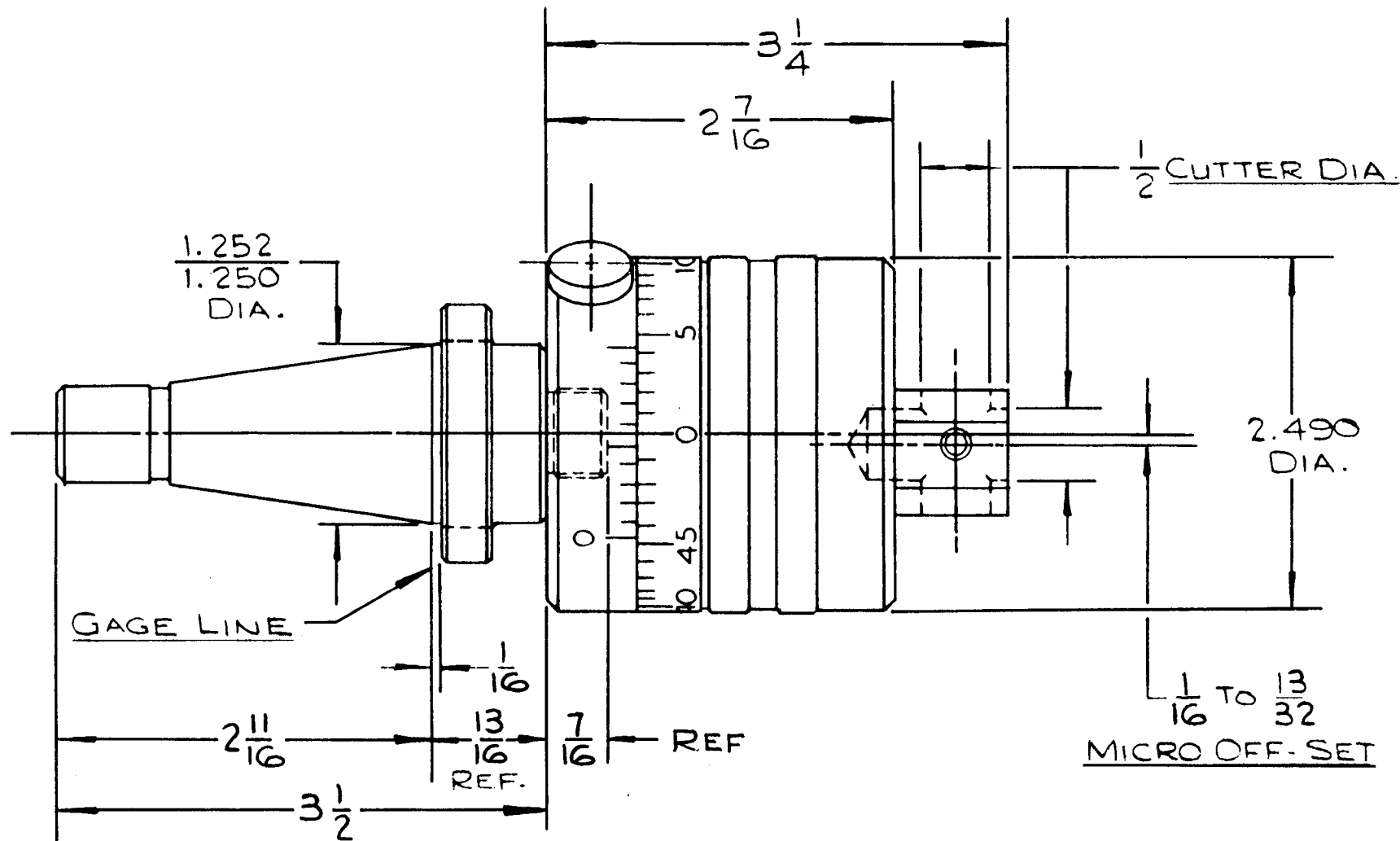

BRIDGEPORT #1-57-0311

50 TENTHSET BORING HEAD & ADAPTER
w/ # 30 M.M.T. MTG.

TENTHSET BORING BARS

BORING HEAD NO.	BORING BAR DIA.	BORING BAR LENGTH	BRIDGEPORT NO.
#37	.375	1.500	1-57-0312
#37	.375	3.000	1-57-0313
#37	.375	5.000	1-57-0314
#50	.500	2.000	1-57-0315
#50	.500	4.000	1-57-0316
#50	.500	6.500	1-57-0317



TENTHSET BORING CUTTERS

BORING HEAD NO.	MINIMUM BORE	MAXIMUM DEPTH	BRIDGEPORT NO.
#37	.18	.56	1-57-0320
#37	.18	.94	1-57-0321
#37	.25	.75	1-57-0322
#37	.25	1.25	1-57-0323
#37	.31	.94	1-57-0324
#37	.31	1.56	1-57-0325
#37	.37	1.12	1-57-0326
#37	.37	1.88	1-57-0327
#50	.25	.75	1-57-0328
#50	.25	1.25	1-57-0329
#50	.31	.94	1-57-0330
#50	.31	1.56	1-57-0331
#50	.37	1.12	1-57-0332
#50	.37	1.88	1-57-0333
#50	.44	1.31	1-57-0334
#50	.44	2.18	1-57-0335
#50	.50	1.50	1-57-0336
#50	.50	2.50	1-57-0337



NOTE: CARBIDE TIPPED CUTTERS AVAILABLE ON REQUEST.

END MILL
ADAPTERS
W/ #30 M.M.T. MTG.

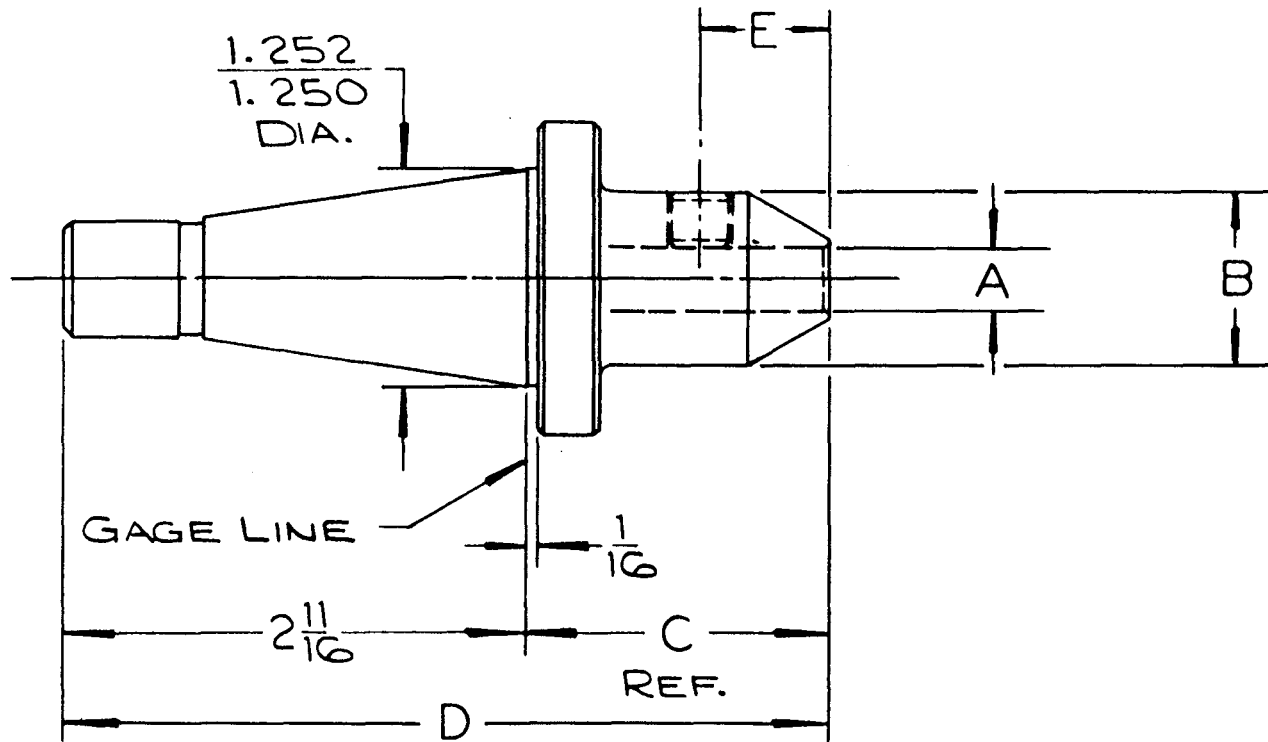

21

A	B	C	D	E	END MILL	BRIDGEPORT NO.
3/16	11/16	1 3/4	4 7/16	9/16	SINGLE OR DOUBLE	1-57-0340
3/8	1".	1 3/4	4 7/16	3/4	SINGLE OR DOUBLE	1-57-0341
1/2	1 1/4	1 3/4	4 7/16	7/8	SINGLE	1-57-0342
5/8	1 7/16	1 3/4	4 7/16	15/16	SINGLE	1-57-0343
3/4	1 13/16	2 1/8	4 13/16	1".	SINGLE	1-57-0344
7/8	1 7/8	2 1/2	5 3/16	1".	SINGLE	1-57-0345
1".	2".	2 11/16	5 3/8	1 1/8	SINGLE	1-57-0346

SHELL MILL
ADAPTERS W/
#30 M.M.T. MTG.

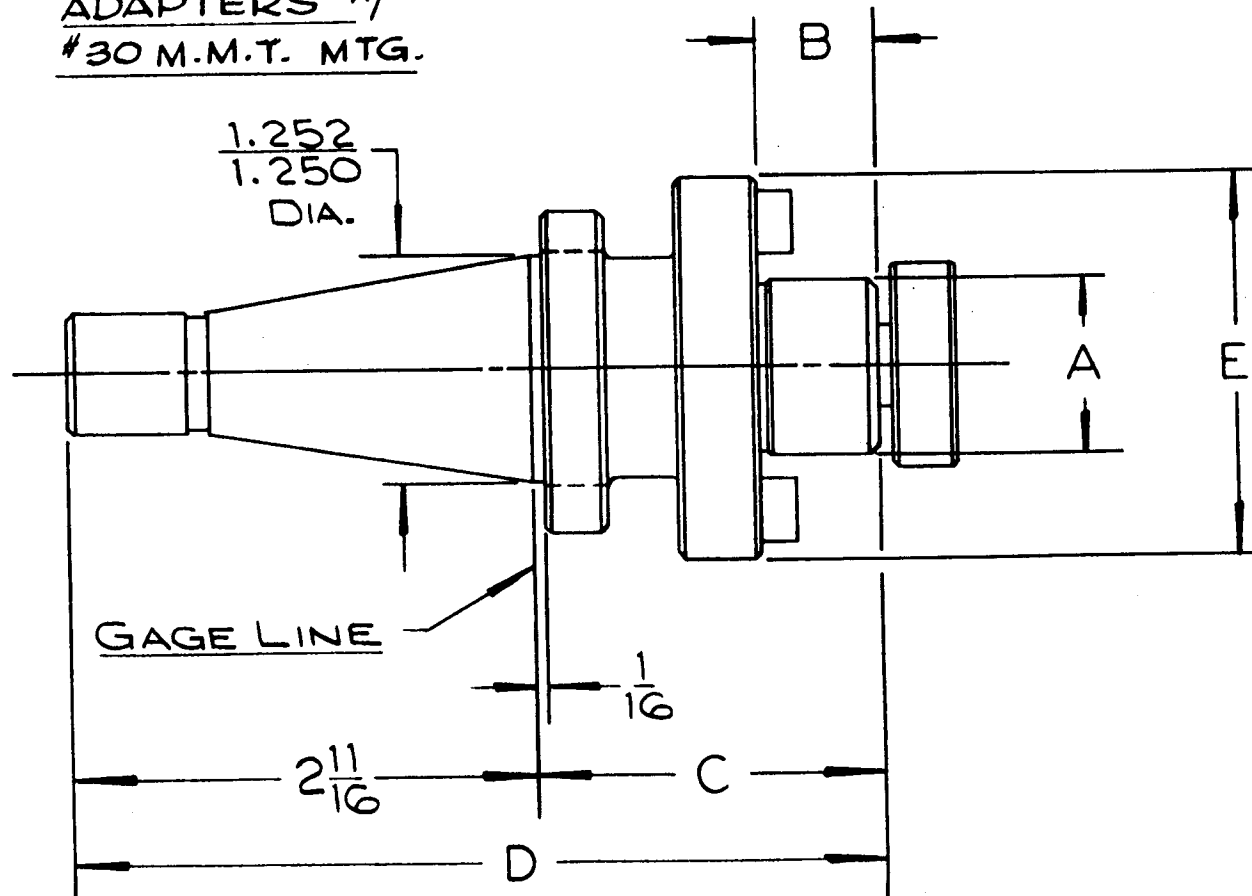

A	B	C	D	E	BRIDGEPORT NO.
.500	9/16	1 3/16	4 1/2	1 7/16	1-57-0350
.750	1 1/16	2 IN.	4 11/16	1 3/4	1-57-0351
1.000	1 1/16	2 IN.	4 11/16	2 3/16	1-57-0352

MORSE TAPER
ADAPTERS
W/ 30 M.M.T. MTG.

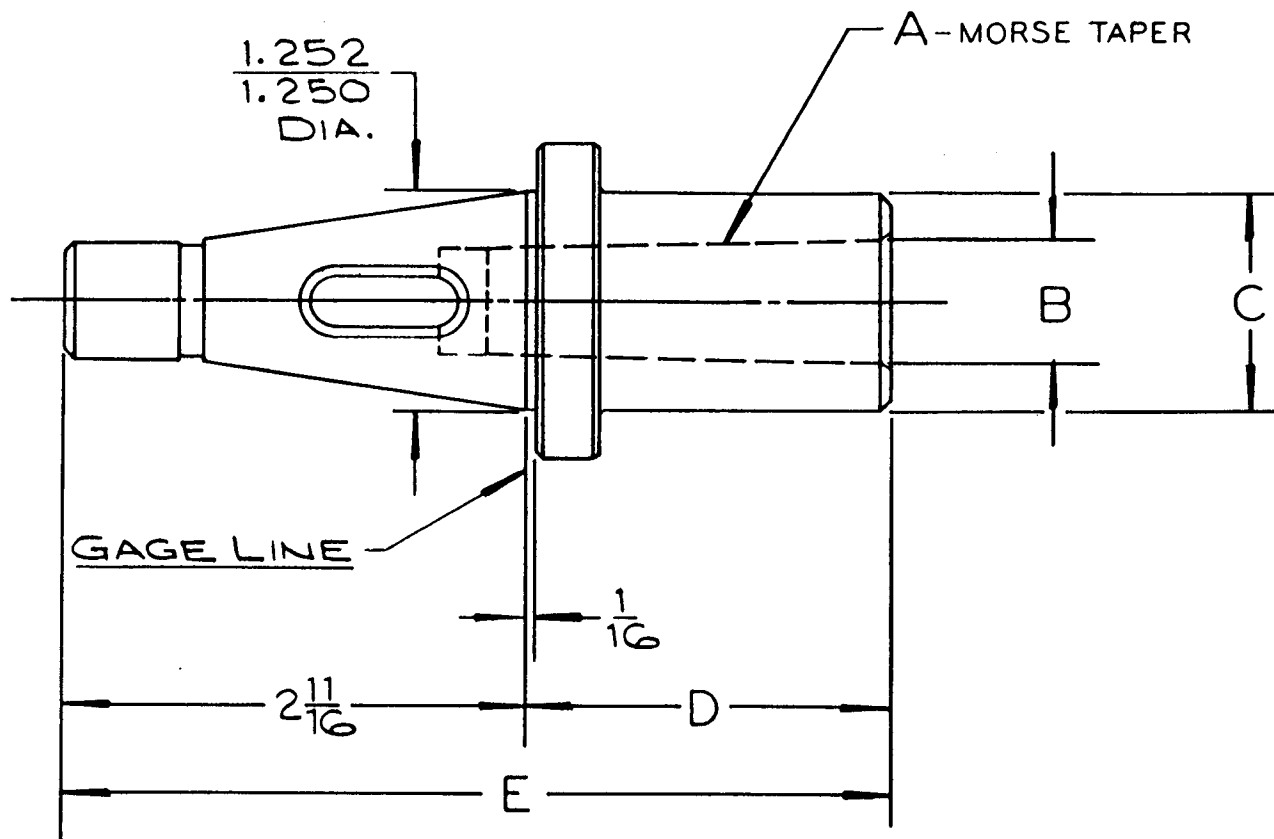

23

A	B	C	D	E	BRIDGEPORT NO.
#1	.475	1 $\frac{1}{2}$ "	1 $\frac{1}{2}$ "	3 $\frac{1}{16}$	1-57-0360
#2	.700	1 $\frac{1}{4}$ "	2 $\frac{1}{8}$ "	4 $\frac{13}{16}$	1-57-0361
#3	.938	1 $\frac{3}{8}$ "	2 $\frac{13}{16}$ "	5 $\frac{1}{2}$ "	1-57-0362

JACOBS TAPER
ADAPTERS W/
#30 M.M.T. MTG.

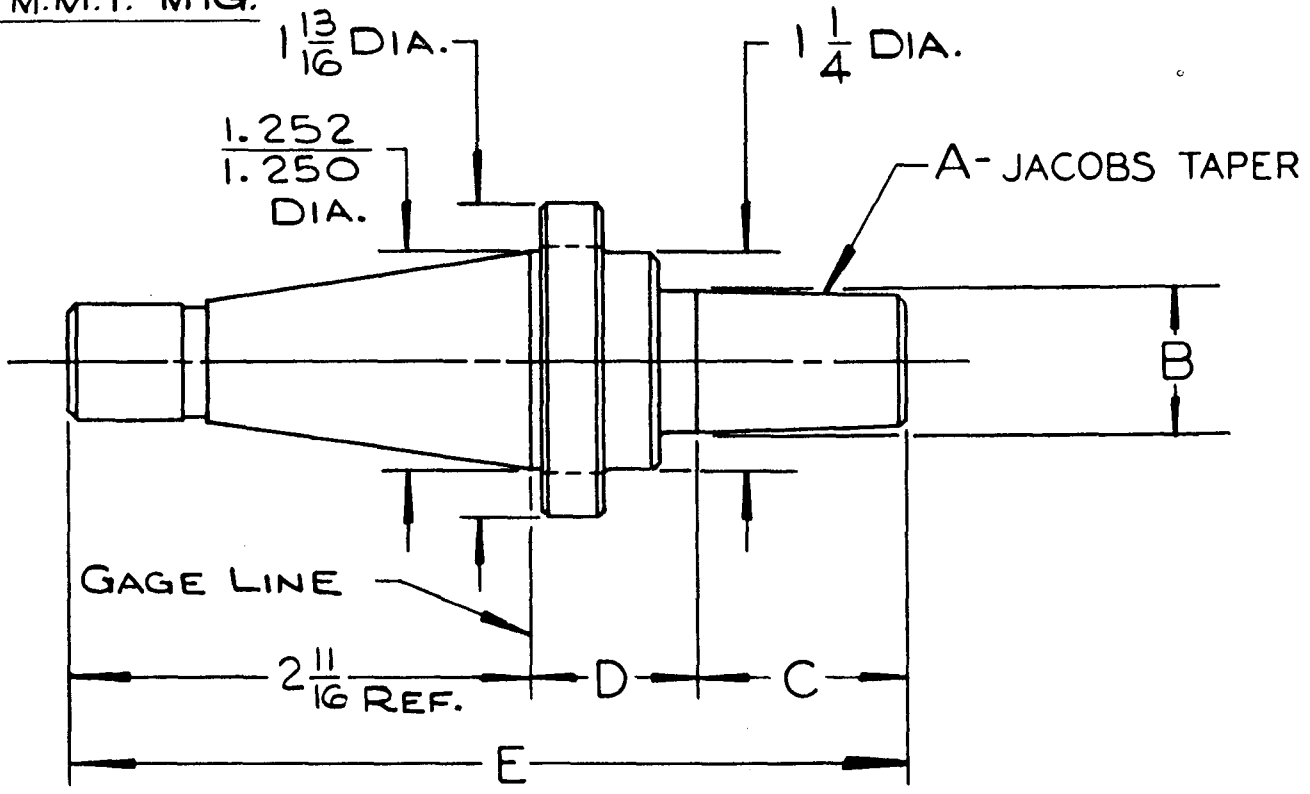

24

A	B	C	D	E	BRIDGEPORT NO.
#3	.812	1-7/32	31/32	4-7/8	1-57-0370
#4	1.125	1-21/32	31/32	5-5/16	1-57-0371
#6	.677	1 IN.	31/32	4-21/32	1-57-0372

1/2" TENSION

HOLDER CAPACITY:
0 THRU 1/4 TAPS
(# 0 THRU 6.35 MM TAPS)

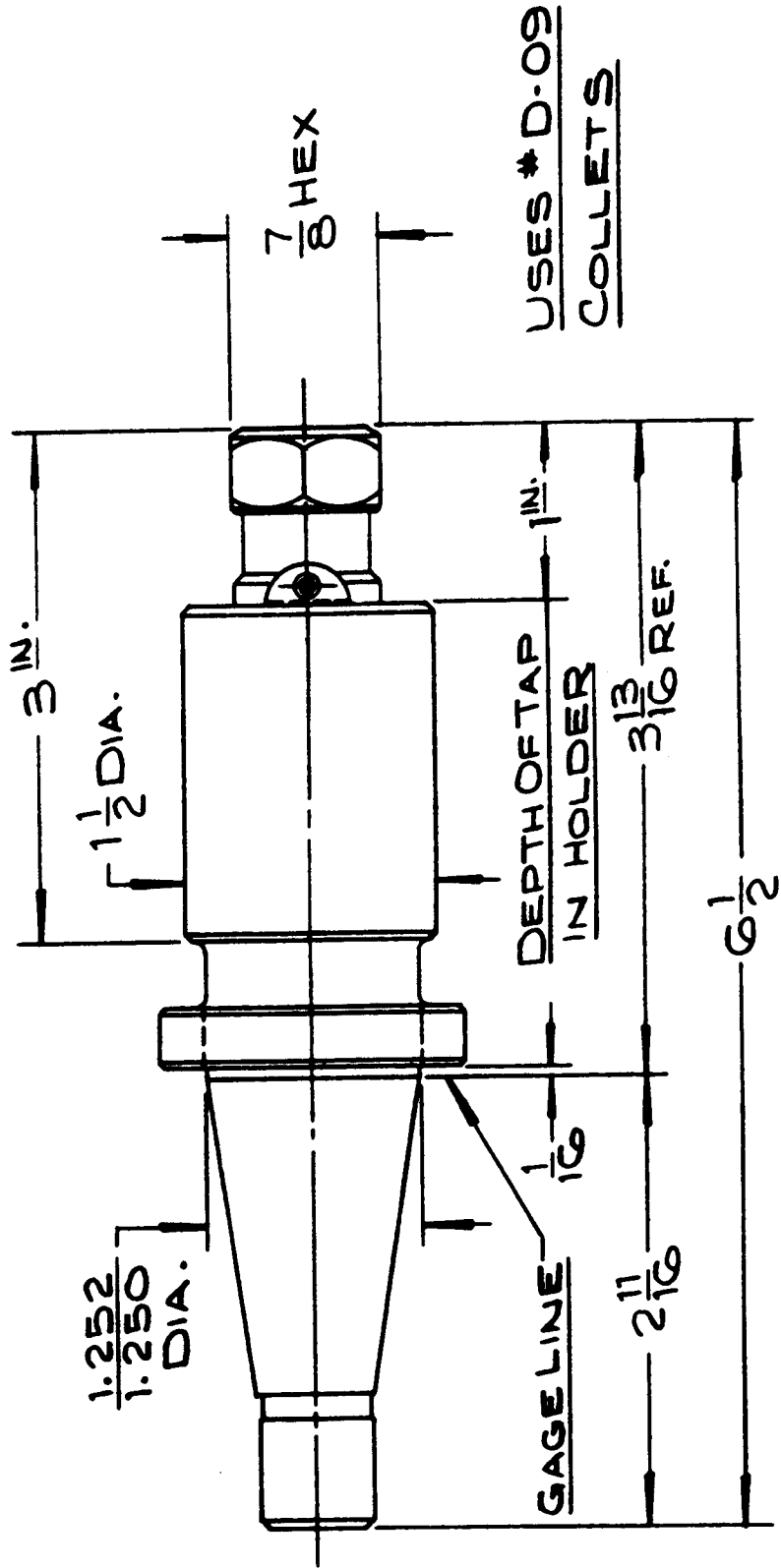

BRIDGEPORT #1-57-0400

D-09 TENSION TYPE TAP HOLDER
W/ # 30 M.M.T. MTG.

1/2" TENSION ~ 1/2" COMPRESSION

HOLDER CAPACITY:

0 THRU 1/4 TAPS
(# 0 THRU 6.35 MM TAPS)

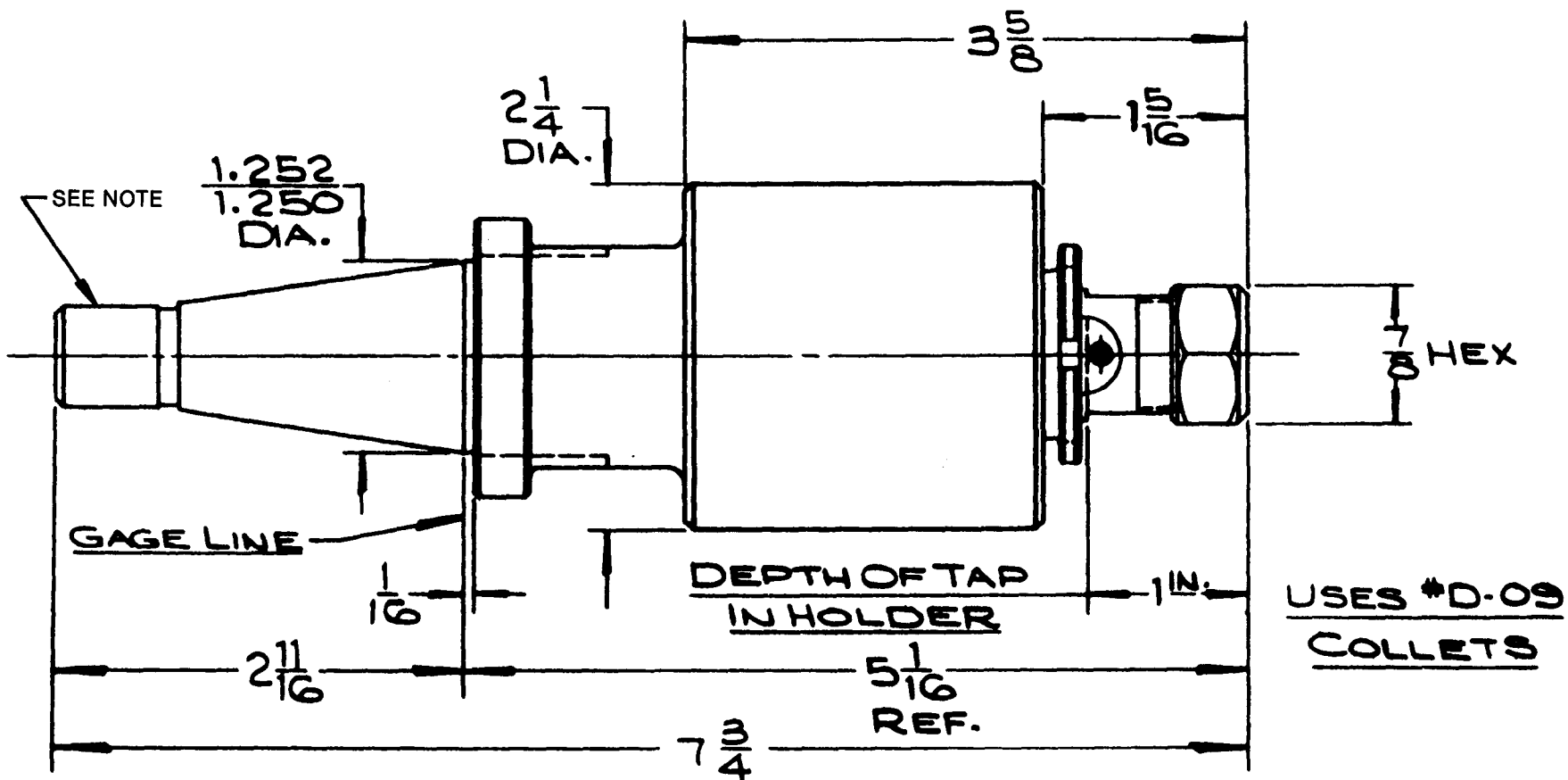

USES #D-09
COLLETS

NOTE: The shank is not internally tapped. This tool is not suited to drawbar operation.

BRIDGEPORT #1-57-0401

#D-09 TENSION & COMPRESSION
'SAFE-DRIVE' TAP HOLDER w/#30 M.M.T. MTG.

1/2" TENSION

HOLDER CAPACITY:

1/4 THRU 7/8 HAND TAP (6.35 THRU 22.225 MM)

1/16 THRU 1/2 PIPE TAP

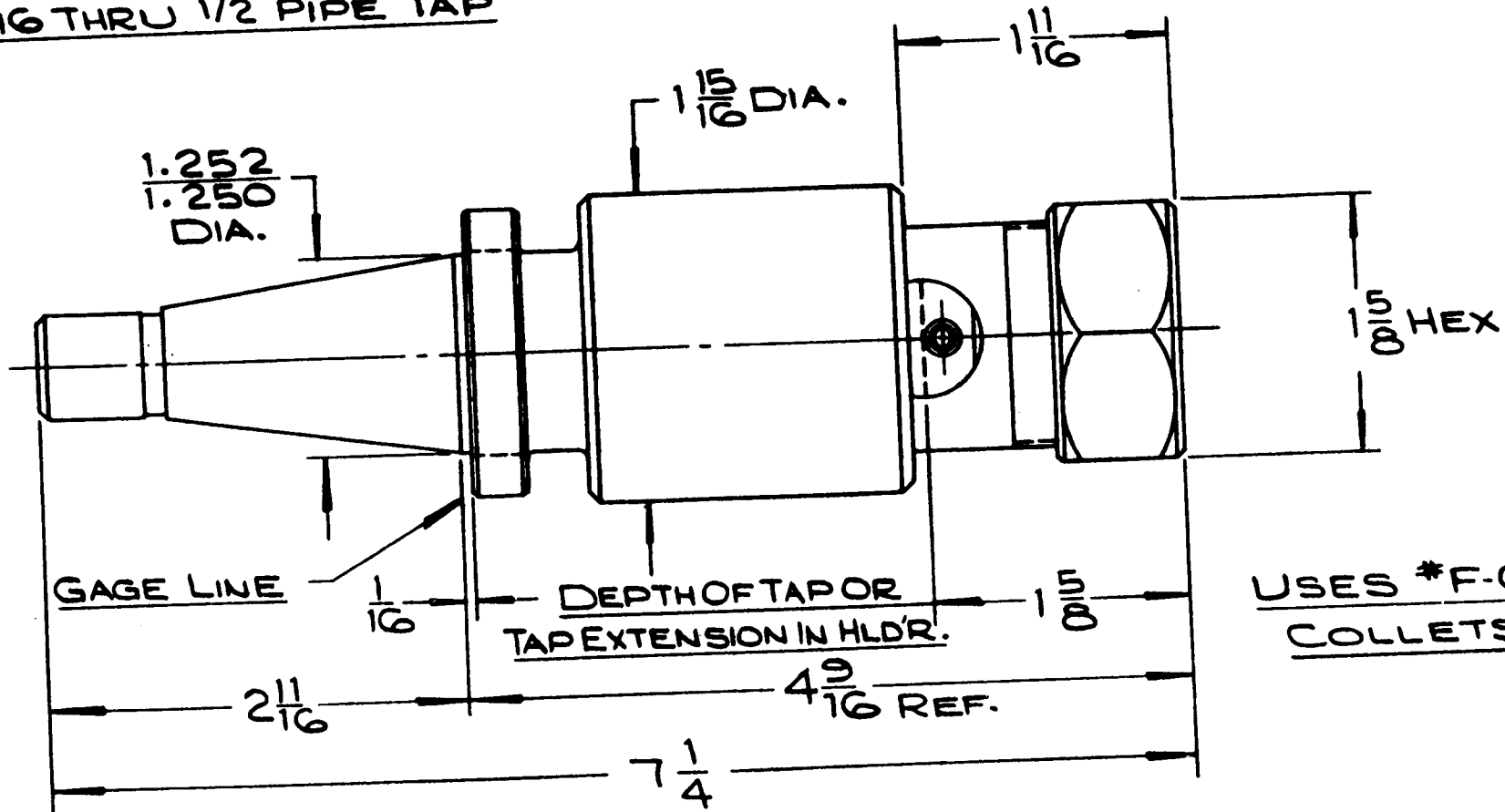

USES #F-09
COLLETS

BRIDGEPORT #1-57-0402

#F-09 TENSION TYPE TAP HOLDER
W/*30 M.M.T. MTG.

1/2" TENSION ~ 1/2" COMPRESSION

HOLDER CAPACITY:
1/4 THRU 7/8 HAND TAP
(6.35 THRU 22.225 MM)

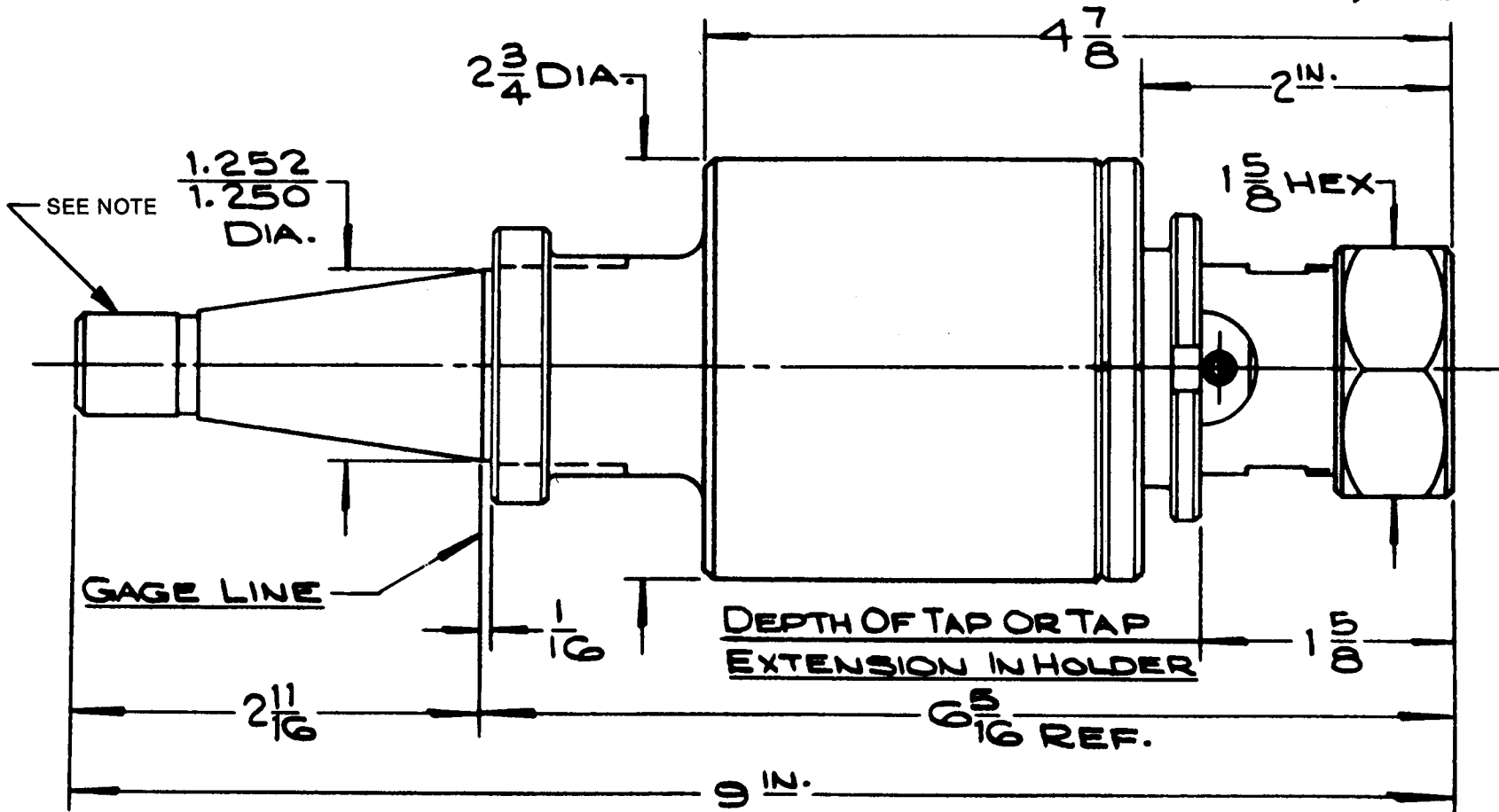

NOTE: The shank is not internally tapped. This tool is not suited to drawbar operation.

USES #F-09
COLLETS

BRIDGEPORT #1-57-0403

#F-09 TENSION & COMPRESSION 'SAFE-DRIVE'
TAP HOLDER W/ #30 M.M.T. MTG.

TAP COLLETS

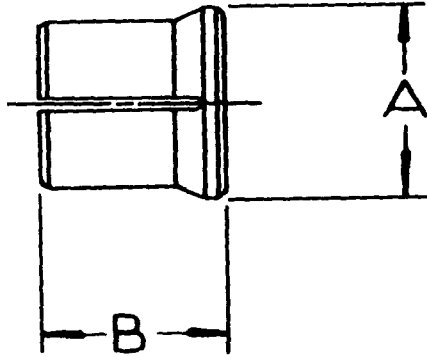

COLLET RANGE	MODEL	A	B
#0 THRU 1/4	D-09	.539	5/8
1/4 THRU 7/8	F-09	1.107	1-3/32
3/4 THRU 1-1/2	G-09	1.813	1-3/16

D-09 #0 THRU 1/4 TAPS				F-09 1/4 THRU 7/8 TAPS				G-09 3/4 THRU 1-1/2 TAPS			
TAP SIZE	HOLE SIZE		BRIDGEPORT NO.	TAP SIZE	HOLE SIZE		BRIDGEPORT NO.	TAP SIZE	HOLE SIZE		BRIDGEPORT NO.
	INCH	MM			INCH	MM			INCH	MM	
#0 thru #6	.141	3.5814	1-57-0410	1/4	.255	6.477	1-57-0430	3/4	.590	14.986	1-57-0450
#8	.168	4.2672	1-57-0411	5/16	.318	8.0772	1-57-0431	7/8	.697	17.7038	1-57-0451
#10	.194	4.9276	1-57-0412	7/16	.323	8.2042	1-57-0432	1"	.800	20.32	1-57-0452
#12	.220	5.588	1-57-0413	1/2	.367	9.3218	1-57-0433	1-1/8	.896	22.7584	1-57-0453
#14 & 1/4	.255	6.477	1-57-0414	3/8	.381	9.6774	1-57-0434	1-1/4	1.021	25.9334	1-57-0454
				9/16	.429	10.8966	1-57-0435	1-3/8	1.108	28.1434	1-57-0455
				5/8	.480	12.1920	1-57-0436	1-1/2	1.233	31.3182	1-57-0456
				3/4	.590	14.986	1-57-0437	3/8 pipe	.700		1-57-0457
				7/8	.697	17.7038	1-57-0438	1/2 pipe	.688		1-57-0458
				1/16 pipe	.313		1-57-0439	5/8 pipe	.813		1-57-0459
				1/8 pipe	.438		1-57-0440	3/4 pipe	.906		1-57-0460
				1/4 pipe	.563		1-57-0441	7/8 pipe	1.094		1-57-0461
				3/8 pipe	.700		1-57-0442	1" pipe	1.125		1-57-0462
				1/2 pipe	.688		1-57-0443	1-1/4 pipe	1.313		1-57-0463

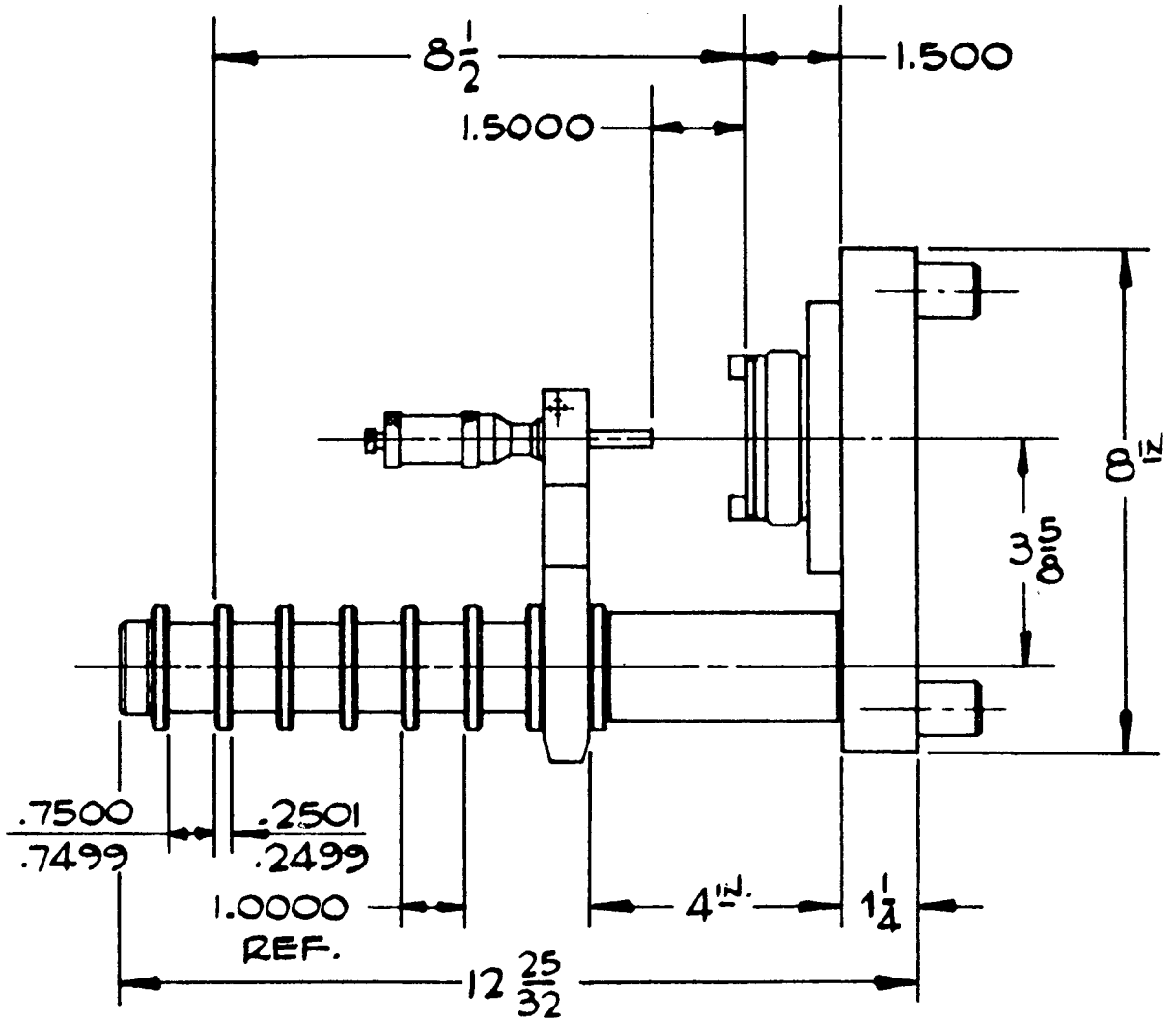
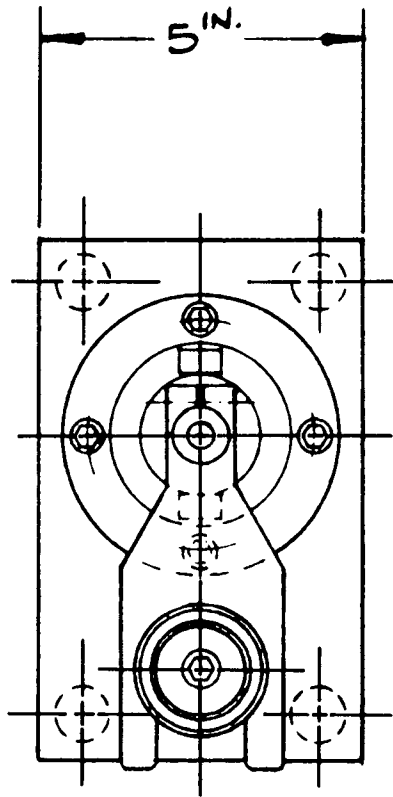

BRIDGEPORT #1-57-0480

PRE SET FIXTURE W/
Nº 30 M.M.T. SOCKET

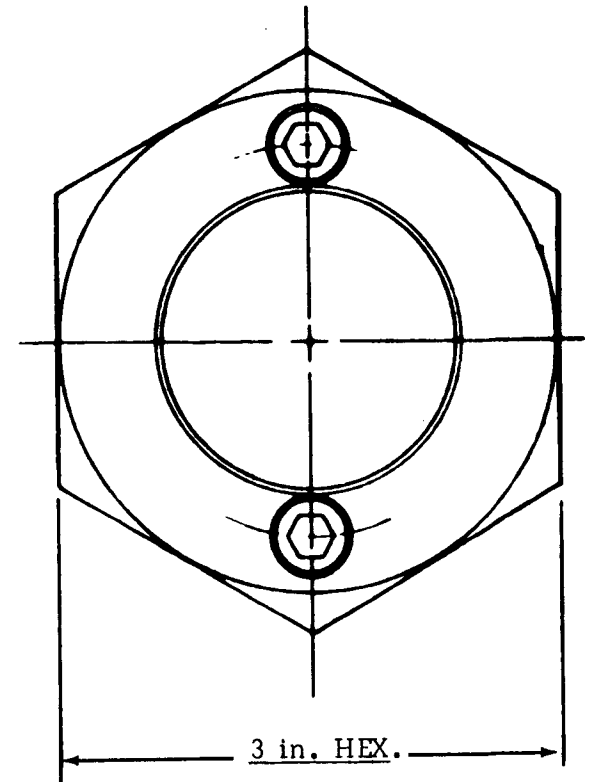
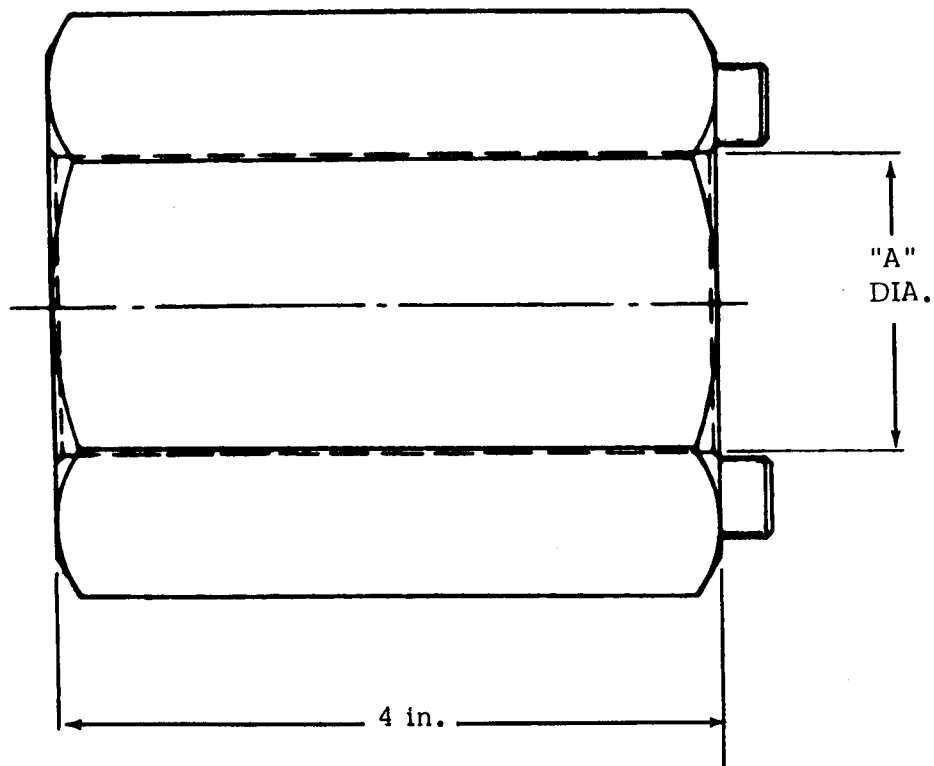

TIGHTENING FIXTURE

MODEL	"A"	BRIDGEPORT No.
#30	1.260	1-57-2335
#40	1.760	1-57-2336

Bridgeport[®]

Bridgeport Machines Division of Textron Inc.

© 1985 Bridgeport Machines Division of Textron Inc. All rights reserved.

Code No. 11040077
MAR 85 1M

G.P.I.
REV.1