

PART NUMBER	COLLET SERIES	A COLLET RANGE	B DIA.	C	D	COLLET NUT	STOP SCREW	COLLET NUT WRENCH
V50BF-100-300	BF100	.118-1.00	2.50	3.00	4.44	BFCN-100	1-1/8-LH	BFG100SW
V50BF-100-600	BF100	.118-1.00	2.50	6.00	6.00	BFCN-100	1-1/8-LH	BFG100SW

Order retention knobs separately, specify machine make and model #.

Includes collet nut and standard stop screw.

Purchase collets and wrenches separately, pages 89 and 95.

NOTE! Collet must be assembled into collet nut before inserting tool or assembling onto chuck.

NOTE! Do not exceed the following torque recommendations: BF100 - 75 ft/lbs.

BRINEY FLEX COLLET CHUCKS

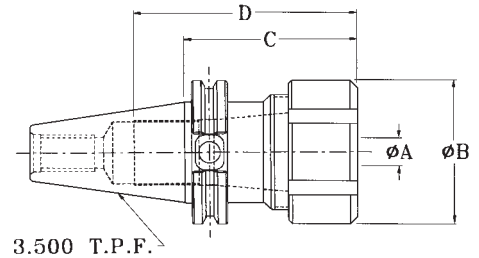

PART NUMBER	COLLET SERIES	A COLLET RANGE	B DIA.	C	D	COLLET NUT	STOP SCREW	COLLET NUT WRENCH
V50CH-100-300	BTG100	.093-1.000	2.245	3.00	4.50	BTGCN-100	1-1/8-LH	BTG100HW
V50CH-100-550	BTG100	.093-1.000	2.245	5.50	7.00	BTGCN-100	1-1/8-LH	BTG100HW
V50CH-100-750	BTG100	.093-1.000	2.245	7.50	9.00	BTGCN-100	1-1/8-LH	BTG100HW
V50CH-150-300	BTG150	.500-1.500	3.25	3.00	4.50	BTGCN-150	1-5/8-LH	BTG150SW
V50CH-150-500	BTG150	.500-1.500	3.25	5.00	7.00	BTGCN-150	1-5/8-LH	BTG150SW
V50CH-150-700	BTG150	.500-1.500	3.25	7.00	9.00	BTGCN-150	1-5/8-LH	BTG150SW

Order retention knobs separately, specify machine make and model #.

Includes collet nut and standard stop screw. Purchase collets and wrenches separately, pages 88 and 94.

NOTE! Collet must be assembled into collet nut before inserting tool or assembling onto chuck.

NOTE! Do not exceed the following torque recommendations:

BTG100 - 75 ft/lbs. BTG150 - 90 ft/lbs. BTG200 - 120 ft/lbs.

TG COLLET CHUCKS

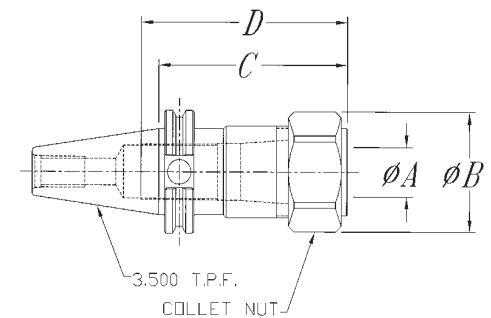

V FLANGE TOOLING

PART NUMBER	COLLET SERIES	A COLLET RANGE	B DIA.	C	D	COLLET NUT	STOP SCREW	COLLET NUT WRENCH
V50BR-16-400	BR16	.019-.393	1.10	4.00	3.00	BRCN-16	7/16-LH	BR16HW
V50BR-16-500	BR16	.019-.393	1.10	5.00	3.00	BRCN-16	7/16-LH	BR16HW
V50BR-16-700	BR16	.019-.393	1.10	7.00	3.00	BRCN-16	7/16-LH	BR16HW
V50BR-20-400	BR20	.039-.511	1.34	4.00	3.00	BRCN-20	9/16-LH	BR20HW
V50BR-20-600	BR20	.039-.511	1.34	6.00	3.00	BRCN-20	9/16-LH	BR20HW
V50BR-25-400	BR25	.039-.630	1.65	4.00	3.00	BRCN-25	M18LH	BR25SW
V50BR-25-600	BR25	.039-.630	1.65	6.00	3.00	BRCN-25	M18LH	BR25SW
V50BR-32-400	BR32	.078-.787	1.97	4.00	3.00	BRCN-32	7/8-LH	BR32SW
V50BR-32-650	BR32	.078-.787	1.97	6.50	3.00	BRCN-32	7/8-LH	BR32SW
V50BR-40-400	BR40	.118-1.024	2.48	4.00	3.00	BRCN-40	1-1/8-LH	BR40SW
V50BR-40-630	BR40	.118-1.024	2.48	6.30	3.00	BRCN-40	1-1/8-LH	BR40SW
V50BR-50-400	BR50	.394-1.339	3.07	4.00	3.00	BRCN-50	1-1/2-LH	BR50SW

Order retention knobs separately, specify machine make and model #.

Includes collet nut and standard stop screw. Purchase collets and wrenches separately, pages 90, 96 and 97.

NOTE! Collet must be assembled into collet nut before inserting tool or assembling onto chuck.

NOTE! Do not exceed the following torque recommendations: BR16 - 40 ft/lbs. BR20 - 65 ft/lbs.

BR25-65 ft/lbs. BR32 - 80 ft/lbs. BR40 - 90 ft/lbs. BR50 - 90 ft/lbs.

ULTRA PRECISION COLLET CHUCKS

