



**MOTOROLA**

# GM300

Mobile Radios

136-162 MHz

146-174 MHz

403-433 MHz

438-470 MHz

465-495 MHz

490-520 MHz

Service Manual



**Radius<sup>®</sup>**

6880902Z32-A



Scope of Manual . . . . .	iii
How to Use This Manual . . . . .	iii
Other Documentation . . . . .	iii
Technical Support . . . . .	iii
Service Policy . . . . .	iii
Ordering Replacement Parts . . . . .	iii
Model Charts . . . . .	iv
Accessories . . . . .	xv
Specifications . . . . .	xvii

## Section 1

### Disassembly/Re-assembly

Radio Disassembly and Assembly . . . . .	1-1
To Remove RF Chassis Shield . . . . .	1-1
To Remove the PA Heatsink . . . . .	1-1
To Remove the RF Circuit Boards . . . . .	1-1
To Remove the Logic Circuit Board . . . . .	1-2
To Remove the PA Circuit Board . . . . .	1-2
To Re-Assemble the Radio . . . . .	1-2
Alignment . . . . .	1-4
Programming . . . . .	1-4
Recommended Test Equipment . . . . .	1-4
Board Replacement and Calibration . . . . .	1-4

## Section 2

### Theory of Operation

RF Board . . . . .	2-1
VHF Receiver Front End, 146-174 MHz . . . . .	2-1
UHF Receiver Front End . . . . .	2-1
Receiver Back End . . . . .	2-2
Frequency Synthesizer . . . . .	2-2
Charge Pump . . . . .	2-5
Loop Filter . . . . .	2-5
Reference Oscillator . . . . .	2-5
VCO's and Buffers . . . . .	2-5
Logic Board . . . . .	2-6
DC Distribution and Regulation . . . . .	2-6
Microcomputer and Logic . . . . .	2-7
Microcomputer Start-Up Routine . . . . .	2-7
Microcomputer Operation-Expanded Logic . . . . .	2-7
Reading or Writing in Memory-Expanded Logic . . . . .	2-8
Programmable I/O's . . . . .	2-8
Receiver Audio . . . . .	2-8
Voice Path . . . . .	2-8
Data Path . . . . .	2-9
Transmitter Audio . . . . .	2-9
Voice Path . . . . .	2-9
Data Path . . . . .	2-9

Transmitter Power Control .....	2-10
Control Line Functions .....	2-10
Power Control Operation .....	2-10
RF Power Amplifiers .....	2-10
1-10 Watt VHF Power Amplifier .....	2-10
10-25 Watt VHF Power Amplifier .....	2-11
25-45 Watt VHF Power Amplifier .....	2-11
1-10 Watt UHF Power Amplifier .....	2-11
10-25 Watt UHF Power Amplifier .....	2-12
25-35/40 Watt UHF Power Amplifiers .....	2-12
Front Panel Boards .....	2-13
Display Board .....	2-13
Display Board (8/16 Freq Models) .....	2-13
Vol/Mic Board .....	2-14
Front Panel Filter Board .....	2-14

### Section 3

#### Jumper-Selectable Options

Overview .....	3-1
Jumper Positions .....	3-1

### Section 4

#### Non-Field Servicable Components

Operation of the Reference Oscillator .....	4-1
Non-Field Servicable Components .....	4-1

#### Schematic Diagrams & Circuit Board Details

Schematic Diagram for HLD8265A and HLD88266A VHF RF Boards, 136-162 MHz .....	1
Circuit Board Details for HLD8265A and HLD8266A VHF RF Boards, 136-162 MHz .....	2
Schematic Diagram for HLD8029A and HLD8031A VHF RF Boards, 146-174 MHz .....	3
Circuit Board Details for HLD8029A and HLD8031A VHF RF Boards, 146-174 MHz .....	4
Schematic Diagram for HLE8229A and HLE8230A UHF RF Boards, 403-433 MHz .....	5
Circuit Board Details for HLE8229A and HLE8230A UHF RF Boards, 403-433 MHz .....	6
Schematic Diagram for HLE8300A and HLE8301A UHF RF Boards, 438-470 MHz .....	7
Circuit Board Details for HLE8300A and HLE8301A UHF RF Boards, 438-470 MHz .....	8
Schematic Diagram for HLE8263A and HLE8264A UHF RF Boards, 465-490 MHz .....	9
Circuit Board Details for HLE8263A and HLE8264A UHF RF Boards, 465-490 MHz .....	10
Schematic Diagram for HLE8227A and HLE8228A UHF RF Boards, 490-520 MHz .....	11
Circuit Board Details for HLE8227A and HLE8228A UHF RF Boards, 490-520 MHz .....	12
Schematic Diagram for HLE8074A Masked Logic Board (2-Layer) (Sheet 1 of 2) .....	13
Schematic Diagram for HLE8074A Masked Logic Board (2-Layer) (Sheet 2 of 2) .....	14
Circuit Board Details for HLN8074A Masked Logic Board (2-Layer) .....	15
Schematic Diagram for HLN8070A Expanded Logic Board (4-Layer) (Sheet 1 of 2) .....	16
Schematic Diagram for HLN8070A Expanded Logic Board (4-Layer) (Sheet 2 of 2) .....	17
Circuit Board Details for HLN8070A Expanded Logic Board (4-Layer) .....	18
Circuit Board Details and Schematic for HLD8293A VHF Power Amplifier, 136-162 MHz, 10-25 Watts .....	19
Circuit Board Details and Schematic For HLD8299A VHF Power Amplifier, 146-174 MHz, 1-10 Watts .....	20
Circuit Board Details and Schematic For HLD8033A VHF Power Amplifier, 146-174 MHz, 10-25 Watts .....	21
Circuit Board Details and Schematic for HLD8287A VHF Power Amplifier, 146-174 MHz, 25-45 Watts .....	22

Circuit Board Details and Schematic for HLE8385A UHF Power Amplifier, 403-433 MHz, 1-10 Watts .....	23
Circuit Board Details and Schematic for HLE8275A UHF Power Amplifier, 403-433 MHz, 25-40 Watts .....	24
Circuit Board Details and Schematic for HLE8267A UHF Power Amplifier, 438-470 MHz, 1-10 Watts .....	25
Circuit Board Details and Schematic for HLE8034A UHF Power Amplifier, 438-470 MHz, 10-25 Watts .....	26
Circuit Board Details, and Schematic for HLE8271A UHF Power Amplifier, 438-470 MHz, 25-40 Watts .....	27
Circuit Board Details and Schematic for HLE8284A UHF Power Amplifier, 465-495 MHz, 25-40 Watts .....	28
Circuit Board Details and Schematic for HLE8269A UHF Power Amplifier, 490-520 MHz, 25-35 Watts .....	29
Circuit Board Detail, Schematic and Parts List for Front Panel Filter Board (01-80704Y83) .....	30
Schematic Diagram and Parts List for HLN8075A Display Board .....	31
Circuit Board Details for HLN8075A Display Board .....	32
Circuit Board Detail, Schematic and Parts List for HLN8071A Volume/Microphone Board .....	33
Exploded View, Schematic, Circuit Board Detail and Parts List for Microphone .....	34
Exploded Mechanical View and Parts List for Radio .....	35

## Parts Lists for RF, Logic, & PA Boards

RF Boards .....	
Logic Boards .....	
PA Boards .....	



## Scope of Manual

This manual is intended for use by experienced technicians familiar with similar types of equipment. It contains all service information required for the equipment described and is current as of the printing date. Changes which occur after the printing date are incorporated by instruction manual revision. These revisions are added to the manuals as the engineering changes are incorporated into the equipment.

## How to Use This Manual

This manual contains introductory material such as model charts, accessories, and specifications, as well as four sections that deal with specific service aspects of the GM300. Refer to the Table of Contents for a general overview of the manual, or to the "Overview" paragraph in each section for a specific overview of the information in that section.

## Other Documentation

Table 1 lists other documentation for the GM300 Mobile Radios.

*Table 1.*

Information	Location
Basic Use of GM300	GM300 Owner's Manual (6880902Z09)
Programming	GM300 RSS Basic Manual (6880902Z36)
	GM300 RSS RapidCall Manual (6880902Z64)

## Technical Support

To obtain technical support, you may call Motorola's Radius Product Services. When you call, we ask that you have ready the model and serial numbers of the respective radio or its parts.

## Service Policy

If malfunctions occur within 30 days that cannot be resolved over the phone with Radius Product Services, a defective major component should be returned. You must obtain authorization from Radius Product Services before returning the component.

## Ordering Replacement Parts

You can order additional components and some piece parts directly through your Radius price pages. When ordering replacement parts, include the complete iden-

tification number for all chassis, kits, and components. If you do not know a part number, include with your order the number of the chassis or kit which contains the part, and a detailed description of the desired component. If a Motorola part number is identified on a parts list, you should be able to order the part through Motorola Parts. If only a generic part is listed, the part is not normally available through Motorola. If no parts list is shown, generally, no user serviceable parts are available for the kit.

### Technical Support

Radius Product Services  
Hwy. 34 West  
Mt. Pleasant, IA 52641 USA  
1-800-356-1520  
319-385-5395 (International)

### Radius 30-Day Warranty

Radius Repair Depot  
Attention: Warranty Return  
1000 W. Washington Street  
Mt. Pleasant, IA 52641 USA  
1-800-356-1520  
319-385-5395 (International)

### Radius Major Component Repair

Radius Repair Depot  
1000 W. Washington Street  
Mt. Pleasant, IA 52641 USA

### Motorola Parts

Worldwide System and  
Aftermarket Products Division  
Attention: Order Processing  
1313 E. Algonquin Road  
Schaumburg, IL 60196

Worldwide System and  
Aftermarket Products Division  
Attention: International Order Processing  
1313 E. Algonquin Road  
Schaumburg, IL 60196

### Customer Service

1-800-422-4210  
1-708-538-8198 (FAX)

### Parts Identification

1-708-538-0021  
1-708-538-8194

## Model Charts

MODEL	FREQ.	DESCRIPTION									
M33GMC00D1A_	8	GM300 12.5 kHz									
M33GMC20D1A_	8	GM300 20/25/30 kHz									
M33GMC09C1A_	16	GM300 12.5 kHz									
M33GMC29C1A_	16	GM300 20/25/30 kHz									
<b>GM300</b> <b>VHF Mobile Radio</b> <b>136 - 162 MHz</b> <b>10 - 25 Watts RF Power</b>											
ITEM											DESCRIPTION
HLD8266_											RF Board 12.5 kHz
HLD8265_											RF Board 20/25/30 kHz
HLN8074_											Logic Board Masked
HLN8070_											Logic Board, Expanded
HLN8075_											Display Board 8/16 Frequency
HLN8071_											Vol/Mic Board
HLN8072_											Front Panel Hardware, 8/16 Freq
HLD8293_											PA Board
HLN8295_											PA Hardware
HLN8076_											Chassis Hardware
Item	Description										
X				HUD3834_	Chassis, 12.5 kHz (Masked)	X	X				X
	X			HUD3833_	Chassis, 20/25/30 kHz (Masked)		X	X			X
		X		HUD3832_	Chassis, 12.5 kHz (Expanded)	X		X			X
			X	HUD3831_	Chassis, 20/25/30 kHz (Expanded)		X	X			X
X	X	X	X	HLD3850_	PA Kit (part of chassis)					X	X
X	X	X	X	HCN3503_	Control Head, 8/16 Channel				X	X	X
X	X			HLN8122_	Front Panel Lens, 8 Channel						
		X	X	HLN8123_	Front Panel Lens, 16 Channel						
X	X			HHN8073_	Housing Kit, masked						
		X	X	HHN8170_	Housing Kit, expanded						
X	X	X	X	HLN8120_	Nameplate						
		X	X	HLN8121_	ROM Kit						
X	X	X	X	HKN4137_	Power Cable						
X	X	X	X	HMN3413_	Microphone w/hangup clip						
X	X	X	X	HLN5189_	Installation Kit						
X	X	X	X	6880902Z09	Owners Manual GM300						
X	X			6880902Z26	Operator Card 8 Channel						
		X	X	6880902Z41	Operator Card 16 Channel						

MODEL	FREQ.	DESCRIPTION																
M03GMC00D2A_	8	GM300 12.5 kHz	<p align="center"><b>GM300 VHF Mobile Radio 146 - 174 MHz 1 - 10 Watts RF Power</b></p>															
M03GMC20D2A_	8	GM300 20/25/30 kHz																
M03GMC09C2A_	16	GM300 12.5 kHz																
M03GMC29C2A_	16	GM300 20/25/30 kHz																
ITEM	DESCRIPTION																	
HLD8029_	RF Board 12.5 kHz																	
HLD8031_	RF Board 20/25/30 kHz																	
HLN8074_	Logic Board Masked																	
HLN8070_	Logic Board, Expanded																	
HLN8075_	Display Board 8/16 Frequency																	
HLN8071_	Vol/Mic Board																	
HLN8072_	Front Panel Hardware, 8/16 Freq																	
HLD8299_	PA Board																	
HLN8274_	PA Hardware																	
HLN8076_	Chassis Hardware																	
		Item	Description															
X		HUD3794_	Chassis, 12.5 kHz (Masked)	X		X												X
	X	HUD3792_	Chassis, 20/25/30 kHz (Masked)		X	X												X
		X	HUD3793_	Chassis, 12.5 kHz (Expanded)	X			X										X
		X	HUD3791_	Chassis, 20/25/30 kHz (Expanded)		X		X										X
X	X	X	X	HLD3852_	PA Kit (part of chassis)												X	X
X	X	X	X	HCN3503_	Control Head, 8/16 Channel					X	X	X						
X	X			HLN8122_	Panel Lens 8 Channel													
		X	X	HLN8123_	Panel Lens 16 Channel													
X	X			HHN8073_	Housing Kit, masked													
		X	X	HHN8170_	Housing Kit, expanded													
X	X	X	X	HLN8120_	Nameplate													
		X	X	HLN8121_	ROM Kit													
X	X	X	X	HKN4137_	Power Cable													
X	X	X	X	HMN3413_	Microphone w/hangup clip													
X	X	X	X	HLN5189_	Installation Kit													
X	X	X	X	6880902Z09	Owners Manual GM300													
X	X			6880902Z26	Operator Card 8 Channel													
		X	X	6880902Z41	Operator Card 16 Channel													



## Model Charts

MODEL	FREQ.	DESCRIPTION
M33GMC00D2A_	8	GM300 12.5 kHz
M33GMC20D2A_	8	GM300 20/25/30 kHz
M33GMC09C2A_	16	GM300 12.5 kHz
M33GMC29C2A_	16	GM300 20/25/30 kHz
<b>GM300</b> <b>VHF Mobile Radio</b> <b>146 - 174 MHz</b> <b>10 - 25 Watts RF Power</b>		
ITEM	DESCRIPTION	
HLD8029_	RF Board 12.5 kHz	
HLD8031_	RF Board 20/25/30 kHz	
HLN8074_	Logic Board Masked	
HLN8070_	Logic Board, Expanded	
HLN8075_	Display Board 8/16 Frequency	
HLN8071_	Vol/Mic Board	
HLN8072_	Front Panel Hardware, 8/16 Freq	
HLD8033_	PA Board	
HLN8069_	PA Hardware	
HLN8076_	Chassis Hardware	

	Item	Description																		
X		HUD3409_	Chassis, 12.5 kHz (Masked)	X		X														X
	X		HUD3410_	Chassis, 20/25/30 kHz (Masked)		X	X													X
		X		HUD3570_	Chassis, 12.5 kHz (Expanded)	X		X												X
		X		HUD3571_	Chassis, 20/25/30 kHz (Expanded)		X	X												X
X	X	X	X	HLD3502_	PA Kit (part of chassis)											X	X			
X	X	X	X	HCN3503_	Control Head, 8/16 Channel					X	X	X								
X	X			HLN8122_	Front Panel Lens, 8 Channel															
		X	X	HLN8123_	Front Panel Lens, 16 Channel															
X	X			HHN8073_	Housing Kit, masked															
		X	X	HHN8170_	Housing Kit, expanded															
X	X	X	X	HLN8120_	Nameplate															
		X	X	HLN8121_	ROM Kit															
X	X	X	X	HKN4137_	Power Cable															
X	X	X	X	HMN3413_	Microphone w/hangup clip															
X	X	X	X	HLN5189_	Installation Kit															
X	X	X	X	6880902Z09	Owners Manual GM300															
X	X			6880902Z26	Operator Card 8 Channel															
		X	X	6880902Z41	Operator Card 16 Channel															

MODEL	FREQ.	DESCRIPTION
M43GMC00D2A_	8	GM300 12.5 kHz
M43GMC20D2A_	8	GM300 20/25/30 kHz
M43GMC09C2A_	16	GM300 12.5 kHz
M43GMC29C2A_	16	GM300 20/25/30 kHz
M43GMR29C2A_	16	GM300 20/25/30 kHz
<b>GM300</b> <b>VHF Mobile Radio</b> <b>146 - 174 MHz</b> <b>25 - 45 Watts RF Power</b>		
ITEM	DESCRIPTION	
HLD8029_	RF Board 12.5 kHz	
HLD8031_	RF Board 20/25/30 kHz	
HLD9002_	RF Board 20/25/30 kHz	
HLN8074_	Logic Board Masked	
HLN8070_	Logic Board, Expanded	
HLN8075_	Display Board 8/16 Frequency	
HLN8071_	Vol/Mic Board	
HLN8072_	Front Panel Hardware, 8/16 Freq	
HLD8287_	PA Board	
HLN8289_	PA Hardware	
HLN8076_	Chassis Hardware	

	Item	Description																		
X		HUD3931_	Chassis, 12.5 kHz (Masked)	X			X													X
	X	HUD3790_	Chassis, 20/25/30 kHz (Masked)		X		X													X
		X	HUD3930_	Chassis, 12.5 kHz (Expanded)	X				X											X
			X	HUD3823_	Chassis, 20/25/30 kHz (Expanded)		X			X										X
			X	HUD3123_	Chassis, 20/25/30 kHz (Expanded)			X		X										X
X	X	X	X	X	HLD3848_	PA Kit (part of chassis)											X	X		
X	X	X	X	X	HCN3503_	Control Head, 8/16 Channel					X	X	X							
X	X				HLN8122_	Front Panel Lens, 8 Channel														
		X	X	X	HLN8123_	Front Panel Lens, 16 Channel														
X	X				HHN8073_	Housing Kit, masked														
		X	X	X	HHN8170_	Housing Kit, expanded														
X	X	X	X	X	HLN8120_	Nameplate														
		X	X	X	HLN8121_	ROM Kit														
X	X	X	X	X	HKN4137_	Power Cable														
X	X	X	X	X	HMN3413_	Microphone w/hangup clip														
X	X	X	X	X	HLN5189_	Installation Kit														
X	X	X	X	X	6880902Z09	Owners Manual GM300														
X	X				6880902Z26	Operator Card 8 Channel														
		X	X	X	6880902Z41	Operator Card 16 Channel														

MODEL	FREQ.	DESCRIPTION
M04GMC00D1A_	8	GM300 12.5 kHz
M04GMC20D1A_	8	GM300 20/25 kHz
M04GMC09C1A_	16	GM300 12.5 kHz
M04GMC29C1A_	16	GM300 20/25 kHz
<b>GM300</b> <b>UHF Mobile Radio</b> <b>403 - 433 MHz</b> <b>1 - 10 Watts RF Power</b>		
ITEM	DESCRIPTION	
HLE8301_	RF Board 12.5 kHz	
HLE8300_	RF Board 20/25 kHz	
HLN8074_	Logic Board Masked	
HLN8070_	Logic Board, Expanded	
HLN8075_	Display Board 8/16 Frequency	
HLN8071_	Vol/Mic Board	
HLN8072_	Front Panel Hardware, 8/16 Freq	
HLE8385_	PA Board	
HLN8386_	PA Hardware	
HLN8076_	Chassis Hardware	

	Item	Description																		
X		HUE3944_	Chassis, 12.5 kHz (Masked)	X		X														X
	X		HUE3945_	Chassis, 20/25 kHz (Masked)		X	X													X
		X		HUE3946_	Chassis, 12.5 kHz (Expanded)	X		X												X
		X		HUE3947_	Chassis, 20/25 kHz (Expanded)		X	X												X
X	X	X	X	HLE3929_	PA Kit (part of chassis)											X	X			
X	X	X	X	HCN3503_	Control Head, 8/16 Channel					X	X	X								
X	X			HLN8122_	Front Panel Lens, 8 Channel															
		X	X	HLN8123_	Front Panel Lens, 16 Channel															
X	X			HHN8073_	Housing Kit, masked															
		X	X	HHN8170_	Housing Kit, expanded															
X	X	X	X	HLN8120_	Nameplate															
		X	X	HLN8121_	ROM Kit															
X	X	X	X	HKN4137_	Power Cable															
X	X	X	X	HMN3413_	Microphone w/hangup clip															
X	X	X	X	HLN5189_	Installation Kit															
X	X	X	X	6880902Z09	Owners Manual GM300															
X	X			6880902Z26	Operator Card 8 Channel															
		X	X	6880902Z41	Operator Card 16 Channel															

MODEL	FREQ.	DESCRIPTION
M44GMC00D1A_	8	GM300 12.5 kHz
M44GMC20D1A_	8	GM300 20/25 kHz
M44GMC09C1A_	16	GM300 12.5 kHz
M44GMC29C1A_	16	GM300 20/25 kHz
<b>GM300</b> <b>UHF Mobile Radio</b> <b>403 - 433 MHz</b> <b>25 - 40 Watts RF Power</b>		
ITEM	DESCRIPTION	
HLE8230_	RF Board 12.5 kHz	
HLE8229_	RF Board 20/25 kHz	
HLN8074_	Logic Board Masked	
HLN8070_	Logic Board, Expanded	
HLN8075_	Display Board 8/16 Frequency	
HLN8071_	Vol/Mic Board	
HLN8072_	Front Panel Hardware, 8/16 Freq	
HLE8275_	PA Board	
HLN8277_	PA Hardware	
HLN8076_	Chassis Hardware	

	Item	Description																		
X		HUE3812_	Chassis, 12.5 kHz (Masked)	X		X														X
	X	HUE3811_	Chassis, 20/25 kHz (Masked)		X	X														X
		X	HUE3810_	Chassis, 12.5 kHz (Expanded)	X		X													X
		X	HUE3809_	Chassis, 20/25 kHz (Expanded)		X	X													X
X	X	X	X	HLE3853_	PA Kit (part of chassis)												X	X		
X	X	X	X	HCN3503_	Control Head, 8/16 Channel					X	X	X								
X	X			HLN8122_	Front Panel Lens, 8 Channel															
		X	X	HLN8123_	Front Panel Lens, 16 Channel															
X	X			HHN8073_	Housing Kit, masked															
		X	X	HHN8170_	Housing Kit, expanded															
X	X	X	X	HLN8120_	Nameplate															
		X	X	HLN8121_	ROM Kit															
X	X	X	X	HKN4137_	Power Cable															
X	X	X	X	HMN3413_	Microphone w/hangup clip															
X	X	X	X	HLN5189_	Installation Kit															
X	X	X	X	6880902Z09	Owners Manual GM300															
X	X			6880902Z26	Operator Card 8 Channel															
		X	X	6880902Z41	Operator Card 16 Channel															

MODEL		FREQ.		DESCRIPTION	
M04GMC00D3A_		8		GM300 12.5 kHz	
M04GMC20D3A_		8		GM300 20/25 kHz	
M04GMC09C3A_		16		GM300 12.5 kHz	
M04GMC29C3A_		16		GM300 20/25 kHz	
<p><b>GM300</b> <b>UHF Mobile Radio</b> <b>438 - 470 MHz</b> <b>1 - 10 Watts RF Power</b></p>					
ITEM		DESCRIPTION			
HLE8301_		RF Board 12.5 kHz			
HLE8300_		RF Board 20/25 kHz			
HLN8074_		Logic Board Masked			
HLN8070_		Logic Board, Expanded			
HLN8075_		Display Board 8/16 Frequency			
HLN8071_		Vol/Mic Board			
HLN8072_		Front Panel Hardware, 8/16 Freq			
HLE8267_		PA Board			
HLN8268_		PA Hardware			
HLN8076_		Chassis Hardware			
Item		Description			
X					HUE3816_ Chassis, 12.5 kHz (Masked) X X X X X X X X
	X				HUE3815_ Chassis, 20/25 kHz (Masked) X X X X X X X X
		X			HUE3814_ Chassis, 12.5 kHz (Expanded) X X X X X X X X
			X		HUE3813_ Chassis, 20/25 kHz (Expanded) X X X X X X X X
X	X	X	X		HLE3770_ PA Kit (part of chassis) X X X X X X X X
X	X	X	X		HCN3503_ Control Head, 8/16 Channel X X X X X X X X
X	X				HLN8122_ Front Panel Lens, 8 Channel X X X X X X X X
		X	X		HLN8123_ Front Panel Lens, 16 Channel X X X X X X X X
X	X				HHN8073_ Housing Kit, masked X X X X X X X X
		X	X		HHN8170_ Housing Kit, expanded X X X X X X X X
X	X	X	X		HLN8120_ Nameplate X X X X X X X X
		X	X		HLN8121_ ROM Kit X X X X X X X X
X	X	X	X		HKN4137_ Power Cable X X X X X X X X
X	X	X	X		HMN3413_ Microphone w/hangup clip X X X X X X X X
X	X	X	X		HLN5189_ Installation Kit X X X X X X X X
X	X	X	X		6880902Z09 Owners Manual GM300 X X X X X X X X
X	X				6880902Z26 Operator Card 8 Channel X X X X X X X X
		X	X		6880902Z41 Operator Card 16 Channel X X X X X X X X

MODEL		FREQ.	DESCRIPTION	
M34GMC00D3A_		8	GM300 12.5 kHz	
M34GMC20D3A_		8	GM300 20/25 kHz	
M34GMC09C3A_		16	GM300 12.5 kHz	
M34GMC29C3A_		16	GM300 20/25 kHz	
<b>GM300 UHF Mobile Radio 438 - 470 MHz 10 - 25 Watts RF Power</b>				
ITEM		DESCRIPTION		
HLE8301_		RF Board 12.5 kHz		
HLE8300_		RF Board 20/25 kHz		
HLN8074_		Logic Board Masked		
HLN8070_		Logic Board, Expanded		
HLN8075_		Display Board 8/16 Frequency		
HLN8071_		Vol/Mic Board		
HLN8072_		Front Panel Hardware, 8/16 Freq		
HLE8034_		PA Board		
HLN8068_		PA Hardware		
HLN8076_		Chassis Hardware		
Item		Description		
X		HUE3820_	Chassis, 12.5 kHz (Masked)	
	X	HUE3819_	Chassis, 20/25 kHz (Masked)	
		X	HUE3818_	Chassis, 12.5 kHz (Expanded)
		X	HUE3817_	Chassis, 20/25 kHz (Expanded)
X	X	X	X	HLE3501_ PA Kit (part of chassis)
X	X	X	X	HCN3503_ Control Head, 8/16 Channel
X	X			HLN8122_ Front Panel Lens, 8 Channel
		X	X	HLN8123_ Front Panel Lens, 16 Channel
X	X			HHN8073_ Housing Kit, masked
		X	X	HHN8170_ Housing Kit, expanded
X	X	X	X	HLN8120_ Nameplate
		X	X	HLN8121_ ROM Kit
X	X	X	X	HKN4137_ Power Cable
X	X	X	X	HMN3413_ Microphone w/hangup clip
X	X	X	X	HLN5189_ Installation Kit
X	X	X	X	6880902Z09 Owners Manual GM300
X	X			6880902Z26 Operator Card 8 Channel
		X	X	6880902Z41 Operator Card 16 Channel

## Model Charts

MODEL	FREQ.	DESCRIPTION
M44GMC00D3A_	8	GM300 12.5 kHz
M44GMC20D3A_	8	GM300 20/25 kHz
M44GMC09C3A_	16	GM300 12.5 kHz
M44GMC29C3A_	16	GM300 20/25 kHz
<b>GM300</b> <b>UHF Mobile Radio</b> <b>438 - 470 MHz</b> <b>25 - 40 Watts RF Power</b>		
ITEM	DESCRIPTION	
HLE8301_	RF Board 12.5 kHz	
HLE8300_	RF Board 20/25 kHz	
HLN8074_	Logic Board Masked	
HLN8070_	Logic Board, Expanded	
HLN8075_	Display Board 8/16 Frequency	
HLN8071_	Vol/Mic Board	
HLN8072_	Front Panel Hardware, 8/16 Freq	
HLE8271_	PA Board	
HLN8272_	PA Hardware	
HLN8076_	Chassis Hardware	
Item	Description	
X	HUE3918_	Chassis, 12.5 kHz (Masked)
X	HUE3822_	Chassis, 20/25 kHz (Masked)
X	HUE3917_	Chassis, 12.5 kHz (Expanded)
X	HUE3821_	Chassis, 20/25 kHz (Expanded)
X X X X	HLE3772_	PA Kit (part of chassis)
X X X X	HCN3503_	Control Head, 8/16 Channel
X X	HLN8122_	Front Panel Lens, 8 Channel
X X	HLN8123_	Front Panel Lens, 16 Channel
X X	HHN8073_	Housing Kit, masked
X X	HHN8170_	Housing Kit, expanded
X X X X	HLN8120_	Nameplate
X X	HLN8121_	ROM Kit
X X X X	HKN4137_	Power Cable
X X X X	HMN3413_	Microphone w/hangup clip
X X X X	HLN5189_	Installation Kit
X X X X	6880902Z09	Owners Manual GM300
X X	6880902Z26	Operator Card 8 Channel
X X	6880902Z41	Operator Card 16 Channel

MODEL	FREQ.	DESCRIPTION
M44GMC00D4A_	8	GM300 12.5 kHz
M44GMC20D4A_	8	GM300 20/25 kHz
M44GMC09C4A_	16	GM300 12.5 kHz
M44GMC29C4A_	16	GM300 20/25 kHz
<b>GM300</b> <b>UHF Mobile Radio</b> <b>465 - 495 MHz</b> <b>25 - 40 Watts RF Power</b>		
ITEM	DESCRIPTION	
HLE8264_	RF Board 12.5 kHz	
HLE8263_	RF Board 20/25 kHz	
HLN8074_	Logic Board Masked	
HLN8070_	Logic Board, Expanded	
HLN8075_	Display Board 8/16 Frequency	
HLN8071_	Vol/Mic Board	
HLN8072_	Front Panel Hardware, 8/16 Freq	
HLE8284_	PA Board	
HLN8286_	PA Hardware	
HLN8076_	Chassis Hardware	
Item	Description	
X	HUE3842_	Chassis, 12.5 kHz (Masked)
X	HUE3841_	Chassis, 20/25 kHz (Masked)
X	HUE3840_	Chassis, 12.5 kHz (Expanded)
X	HUE3839_	Chassis, 20/25 kHz (Expanded)
X X X X	HLE3847_	PA Kit (part of chassis)
X X X X	HCN3503_	Control Head, 8/16 Channel
X X	HLN8122_	Front Panel Lens, 8 Channel
X X	HLN8123_	Front Panel Lens, 16 Channel
X X	HHN8073_	Housing Kit, masked
X X	HHN8170_	Housing Kit, expanded
X X X X	HLN8120_	Nameplate
X X	HLN8121_	ROM Kit
X X X X	HKN4137_	Power Cable
X X X X	HMN3413_	Microphone w/hangup clip
X X X X	HLN5189_	Installation Kit
X X X X	6880902Z09	Owners Manual GM300
X X	6880902Z26	Operator Card 8 Channel
X X	6880902Z41	Operator Card 16 Channel



Model Charts

MODEL	FREQ.	DESCRIPTION
M44GMC00D5A_	8	GM300 12.5 kHz
M44GMC20D5A_	8	GM300 20/25 kHz
M44GMC09C5A_	16	GM300 12.5 kHz
M44GMC29C5A_	16	GM300 20/25 kHz
<b>GM300</b> <b>UHF Mobile Radio</b> <b>490 - 520 MHz</b> <b>25 - 35 Watts RF Power</b>		
ITEM	DESCRIPTION	
HLE8228_	RF Board 12.5 kHz	
HLE8227_	RF Board 20/25 kHz	
HLN8074_	Logic Board Masked	
HLN8070_	Logic Board, Expanded	
HLN8075_	Display Board 8/16 Frequency	
HLN8071_	Vol/Mic Board	
HLN8072_	Front Panel Hardware, 8/16 Freq	
HLE8269_	PA Board	
HLN8270_	PA Hardware	
HLN8076_	Chassis Hardware	

	Item	Description																			
X		HUE3838_	Chassis, 12.5 kHz (Masked)	X		X															X
	X		HUE3837_	Chassis, 20/25 kHz (Masked)		X	X														X
		X		HUE3836_	Chassis, 12.5 kHz (Expanded)	X		X													X
		X		HUE3835_	Chassis, 20/25 kHz (Expanded)		X	X													X
X	X	X	X	HLE3771_	PA Kit (part of chassis)											X	X				
X	X	X	X	HCN3503_	Control Head, 8/16 Channel					X	X	X									
X	X			HLN8122_	Front Panel Lens, 8 Channel																
		X	X	HLN8123_	Front Panel Lens, 16 Channel																
X	X			HHN8073_	Housing Kit, masked																
		X	X	HHN8170_	Housing Kit, expanded																
X	X	X	X	HLN8120_	Nameplate																
		X	X	HLN8121_	ROM Kit																
X	X	X	X	HKN4137_	Power Cable																
X	X	X	X	HMN3413_	Microphone w/hangup clip																
X	X	X	X	HLN5189_	Installation Kit																
X	X	X	X	6880902Z09	Owners Manual GM300																
X	X			6880902Z26	Operator Card 8 Channel																
		X	X	6880902Z41	Operator Card 16 Channel																

## Accessories

Radius offers many accessories to increase communications efficiency. Some of the accessories available are listed below. For a complete list, consult your Radius dealer.

### Antennas:

HAD4007_R	VHF 146-150.8 MHz, 1/4 wave roof mount
HAD4008_R	VHF 150.8-162 MHz, 1/4 wave roof mount
HAD4009_R	VHF 162-174 MHz, 1/4 wave roof mount
HAD4014_R	VHF 146-172 MHz, 3db gain roof mount
HAE4003_R	UHF 450-470 MHz, 1/4 wave roof mount
HAE4011_R	UHF 450-470 MHz, 3.5 db gain roof mount
HAE4019_R	UHF 450-470 MHz, 5 db gain roof mount
HAE4002_R	UHF 403-430 MHz, 1/4 wave roof mount
HAE4010_R	UHF 406-420 MHz, 3.5 db gain roof mount
HAE4004_R	UHF 470-512 MHz, 1/4 wave roof mount
HAE4012_R	UHF 470-494 MHz, 3.5 db gain roof mount
HAE4013_R	UHF 494-512 MHz, 5 db gain roof mount

### Installation Accessories:

HLN9284_R	Key lock mount
HLN5189_R	Non-locking bracket
HLN5226_R	Extra stability mount (use with HLN5189)
HLN9450_R	45 - 60 degree floor mount wedge (requires HLN9404)
HLN9404_R	Sleeve mounting bracket
HKN4137_R	Power cable w/ 15 Amp fuse
HLN5282_R	Mini-UHF connector
HKN9557_R	PL259/Mini-UHF antenna adapter - 8 inch cable
HLN8027_R	Mini-UHF to BNC antenna adapter
HLN8097_R	Removable slide mount tray package
HLN8098_R	Radio slide mount tray
HLN8099_R	Vehicle slide mount tray
HLN8413_R	Slidemount tray bracket
HLN8143_R	Remote mount kit (17 foot length)
HLN8144_R	Remote mount kit (8 foot length)
HLN9027_R	In-Dash mounting kit

### Control Station Accessories:

HMN1038_R	Desk Microphone
HMN3000_R	Desk Microphone (black)
HPN1007_R	Power supply, 117 Vac (for 25 Watt or less radio models only) <sup>1</sup>
HPN4001_R	Power supply and cables, 117 Vac (for any radio model up to 45 Watts)
HKN4139_R	Low power control station power cable (for HPN1007_R)
HKN9455_R	High power control station power cable (for HPN4001_R)

### Microphones:

HMN3596_R	Compact Microphone with 7 foot cord
HMN1035_R	Heavy Duty Palm Microphone with 10.5 foot cord
HMN1037_R	Touch-code Microphone with hang-up clip
TDN8305_R	Touch-code Microphone with backlit keypad & hang-up clip
TMN6169_R	Touch-code Microphone with memory dial, backlit keypad & hang-up clip
HMN3141_R	Handset with hang-up cup
HLN9559_R	7 foot coil cord Heavy Duty Microphones
HLN9560_R	10.5 foot extended coil cord for Heavy Duty Microphones
HLN9073_R	Microphone hang-up clip (all microphones)

1. Convertible to 230 Vac by changing internal switch and modifying the power cord.

## Accessories

**Accessories / Kits Interfacing with the 16 Pin Connector:**

HKN9327_R	Ignition switch cable
HSN8145_R	7.5 Watt external speaker - for receiver audio
HLN9457_R	Hardware kit-includes 16 connector pins, (9) 8" wires with pins & extra housing
HLN9328_R	Horn/Lights relay and cable (external alarm)
HLN9329_R	Emergency pushbutton switch and cable
HLN9330_R	Emergency footswitch and cable
HLN8375_R	DTMF Decoder board (mounts inside radio - soldering required)
HLN3145_R	Public Address kit <sup>2</sup>
HLN3333_	Repeater Interface kit
TDN8300_	DC Remote Adapter - 2 channel operation (requires at least one L1662 deskset)
TDN8301_	Tone Remote Adapter - 2 channel operation (requires at least one L1663 deskset)
L1661	C100 Extended Local Deskset
TDN8196	i50X Low Tier Radio-Telephone Interconnect and cable
TDN7891	i150X Mid Tier Radio-Telephone Interconnect and cable
TDN7892	i250X High Tier Radio-Telephone Interconnect and cable
HLN9573_R	Shorting Plug - fills microphone jack when no microphone is being used

**Manuals:**

6880902Z26	Operator's card - GM300 8 channel radios
6880902Z41	Operator's card - GM300 16 channel radios
6880902Z09	Owner's manual - GM300
6880902Z32	Service manual - GM300

---

2. The Public Address kit allows from one to five HSN1000\_ amplified speakers. A minimum of one HSN1000\_ speaker is required. One HKN9323\_R (8 foot) cable or one HKN9324\_R (15 foot) cable is required for each HSN1000\_ speaker.

# Specifications

## GENERAL

	VHF					UHF						
Model Series:	M03GMC	M33GMC	M33GMC	M43GMC	M43GMR	M04GMC	M34GMC	M44GMC	M44GMC	M44GMC	M44GMC	
Frequency Range:	146-174 MHz	136-162 MHz	146-174 MHz			403-433 MHz	438-470 MHz	438-470 MHz	403-433 MHz	438-470 MHz	465-495 MHz	490-520 MHz
RF Output:	1-10 W*	10-25 W*			45 W	25-45 W	1-10 W*	10-25 W*	25/40 W	25-40 W*	25/40 W	25/35 W
Channel Capacity:	8 or 16											
Frequency Separation:	28 MHz					32 MHz	32 MHz	30 MHz	32 MHz	30 MHz		
Primary Input Voltage EIA: CEPT 84:	13.8 ±10% 13.2 ±20%											
FCC Designation:	ABZ99FT3032	??	ABZ99FT3030	ABZ99FT3033	??	??	ABZ99FT4033	ABZ99FT4030	ABZ99FT4032	ABZ99FT4034	Pending	Pending
Typical Current Drain Rated Audio (7.5 W):	1.5A											
Transmit:	4.0A	??	7.0A	15.0A	??	??	4.0A	7.5A	12.5A			
Standby:	400 mA											
Squelch Capability:	Tone Coded, Digital Coded and/or Carrier Squelch											
Dimensions:	2" x 7" x 7.75" (50.8 x 178 x 198 mm)											
Weight:	61 z. (1.7 kg)											

\*Continuously variable power

## TRANSMITTER

	VHF		UHF	
Frequency Stability (-30°C to +60°C):	±.00025%			
Spurs/Harmonics 1 to 25 W: >25 W: Exceptions:	-36 dBm (0.25 µW) -13 dBm (50 µW) (403-433 MHz)/-36 dBm (0.25 µW)			
Audio Response: (From a 6 dB/Oct. Pre-Emphasis 300-3000 Hz, 2550 Hz @ 12.5 kHz)	+1 / -3 dB			
Audio Distortion: (@ 1000 Hz, 60% of Rated Max. Deviation)	<3% EIA			
FCC Modulation @20/25/30 kHz: @12.5 kHz:	16KOF1D, 16KOF2D, 16KOF3E, 11KOF1D, 11KOF2D, 11KOF3E			
Output Impedance:	50 ohms			
Modulation Sensitivity:	80 mV for 60% max. deviation at 1000 Hz			
Channel Spacing:	20/25/30 kHz	12.5 kHz	20/25/30 kHz	12.5 kHz
FM Noise EIA: CEPT 84:	45 dB 55 dB	40 dB 50 dB	40 dB 50 dB	35 dB 45 dB

## OPTIONAL SIGNALLING FEATURES WITH RAPIDCALL PACKAGE

Available in 16-Channel Models Only

Signalling Format: encode/decode	PTT ID	Call Alert	Voice Sel/Call	Emergency	Radio Check
MDC-1200:	X	X	X	X	X
Quick-Call II:		X	X		
DTMF:	X	X	X		
Start (encode only):	X			X	

Also includes Singletone Repeater Access &amp; DTMF - ANI for Phone Access &amp; Select V Signalling.

## MILITARY STANDARDS 810 C, D, & E

Applicable MIL-STD	810C		810D		810E	
	Methods	Procedures	Methods	Procedures	Methods	Procedures
Low Pressure:	500.1	1	500.2	1	500.3	1
High Temperature:	501.1	1, 2	501.2	1, 2	501.3	1, 2
Low Temperature:	502.1	1	502.2	1, 2	502.3	1, 2
Temperature Shock:	503.1	1	503.2	1	503.3	1
Solar Radiation:	505.1	1	505.2	1	505.3	1
Rain:	506.1	2	506.2	2	506.3	2
Humidity:	507.1	2	507.2	2	507.3	2
Salt Fog:	509.1	1	509.2	1	509.3	1
Dust:	510.1	1	510.2	1	510.3	1
Vibration:	514.2	8, 10	514.3	1	514.4	1
Shock:	516.2	1, 3, 5	516.3	1, 5	516.4	1, 5

## RECEIVER

	VHF		UHF	
Channel Spacing:	12.5 kHz	20/25/30 kHz	12.5 kHz	20/25 kHz
Sensitivity EIA: 12 dB SINAD: CEPT 84: 20 dB SINAD:	0.35 µV 0.45 µV	0.30 µV 0.40 µV	0.35 µV 0.45 µV	0.30 µV 0.40 µV
Squelch:	10 dB SINAD			
Selectivity EIA: CEPT 84:	-70 dB -70 dB	-80 dB -80 dB	-65 dB -65 dB	-75 dB -75 dB
Intermodulation* EIA: CEPT 84:	-70 dB -73 dB	-78 dB -73 dB	-65 dB -70 dB	-75 dB -70 dB
Frequency Stability: (-30°C to +60°C):	±.00025%			
Spur Rejection EIA: CEPT 84:	-80 dB -75 dB		-75 dB -70 dB	
Image Rejection EIA: CEPT 84:	-80 dB -80 dB		-75 dB -75 dB	
Audio Output: External Speaker (8Ω) EIA (@ <5% Dist): CEPT 84 (@ <10% Dist): Internal Speaker:	7.5 W 5.0 W 3.0 W Nominal			
EIA Usable Bandwidth:	1.2 kHz	20. kHz	1.2 kHz	2.0 kHz
Input Impedance:	50 Ω			

\* Local mode provides an additional 10 dB protection against wideband interference.



### Radio Disassembly and Assembly

#### To Remove Control Head & Chassis Covers

1. Remove control head mounting screws (Figure 1-1).
2. Pull control head off and away from the radio.
3. Carefully remove control head connectors from chassis.
4. Remove the two chassis cover screws from each side (Figure 1-1).
5. Remove top and bottom covers from chassis.

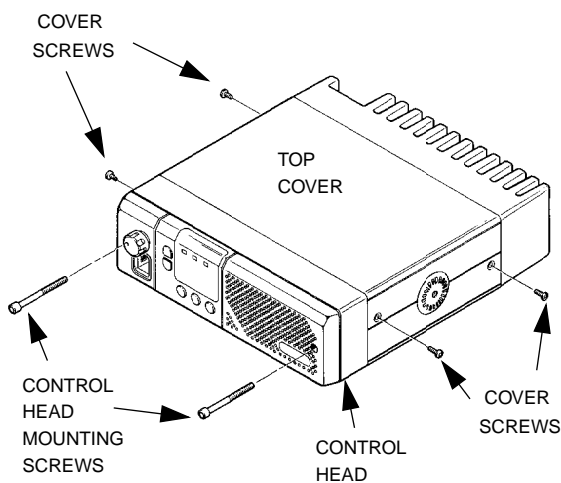

Figure 1-1.

#### To Remove RF Chassis Shield

Remove RF chassis shield by prying each of the four corners at the indentations provided (Figure 1-2). Be careful not to over bend any one corner.

#### To Remove the PA Heatsink

1. Disconnect the transmit and receive coaxial cables from the RF board (Figure 1-3).
2. Disconnect the 6-pin connector from the logic board (Figure 1-4).

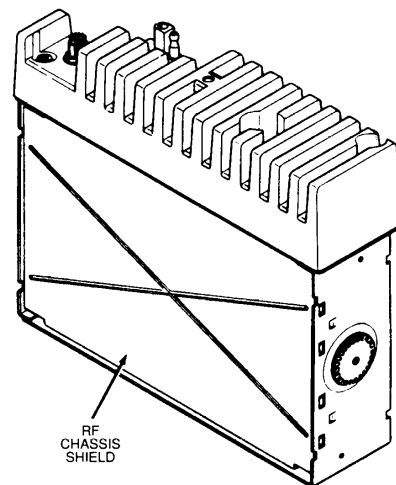

Figure 1-2.

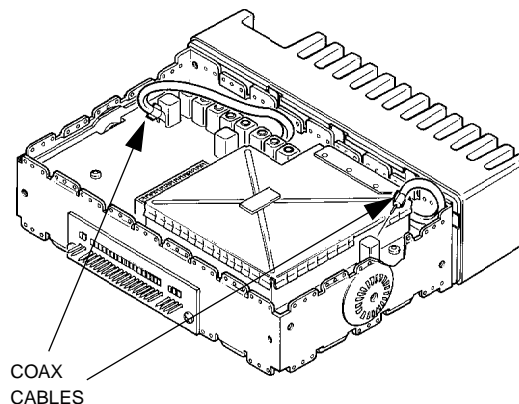

Figure 1-3.

3. Remove the heatsink mounting screws (Figure 1-4).
4. Pull heatsink off of chassis while carefully feeding the transmit and receive coax cables through their respective holes in the chassis.

#### To Remove the RF Circuit Boards

1. After the PA heatsink has been removed, pry off the RF shield (Figure 1-5). Be careful not to over bend any one corner or side.

## Radio Disassembly and Assembly

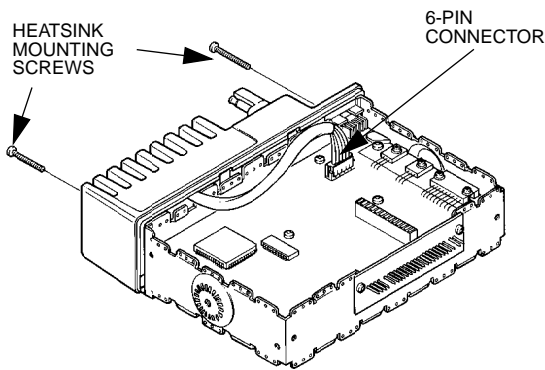

Figure 1-4.

2. After removing the RF shield, remove all RF board mounting screws and take out the RF board (Figure 1-5).

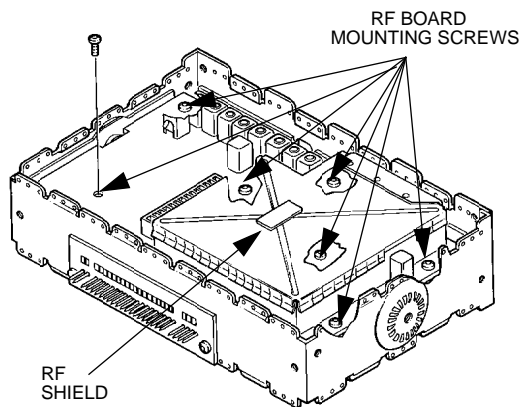

Figure 1-5.

**To Remove the Logic Circuit Board**

1. After the RF board has been removed, turn the radio over and pry off the logic shield, again being careful not to bend any one corner or side.
2. Remove all logic board mounting screws (Figure 1-6).
3. Remove the two filter board screws from the front of the chassis (Figure 1-6). The logic and filter boards can now be lifted out of the chassis.

**To Remove the PA Circuit Board**

1. Remove the power amplifier shield by carefully prying each corner and side until you can slide the shield off easily (Figure 1-7).
2. Remove the shield completely by guiding the coaxial cables out.

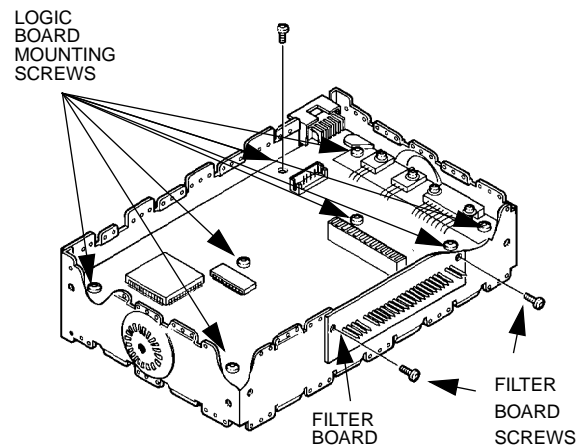

Figure 1-6.

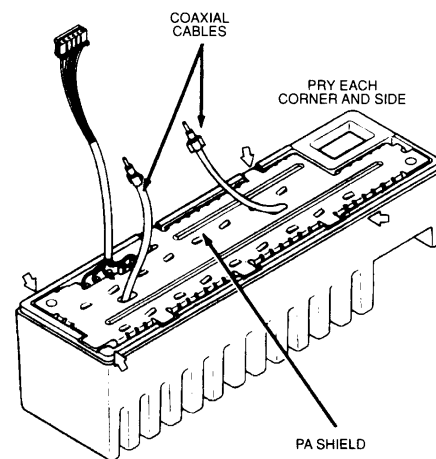

Figure 1-7.

3. Unsolder the A+ power connector feed-thru leads and the antenna connector lead (Figure 1-9).
4. UHF ONLY - Remove the stud mount transistor mounting nut from the back of the heat-sink (Figure 1-8).
5. Remove two power device mounting screws and all PA board mounting screws (Figure 1-9), and then take out the PA board.

**To Re-Assemble the Radio**

Reverse the disassembly procedure and tighten all screws to the torques specified in Table 1-1.

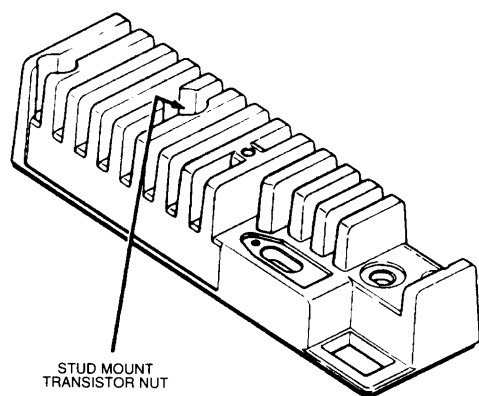

Figure 1-8.

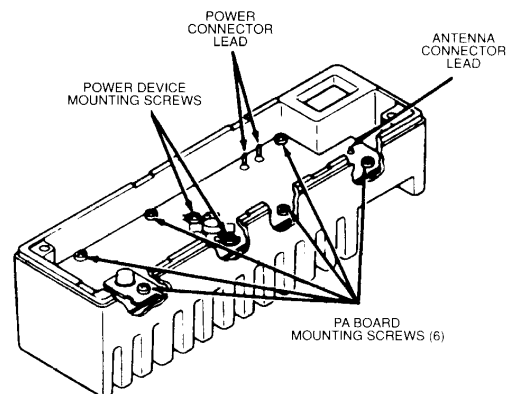

Figure 1-9.

Table 1-1. Fasteners, Tools and Torques

Part Number	Description	Location	Qty	Drv	Input Torq.	Repair Torq.
03-10945A11	M3 x 8 Plastite Slit Torx® Pan Hd.	Control Head Board and Internal Speaker	9	T10	8 in.-lbs.	8 in.-lbs.
03-80270L01	M4 x 0.7 x 38 Mach. Torx® Cap Scr Blk	Control Head Mount	2	T15	8 in.-lbs.	8 in.-lbs.
03-80271L01	M4 x 0.7 x 27 Mach. Slit Torx® Pan Hd Blk	Heatsink Mount	2	T15	12-14 in.-lbs.	12-14 in.-lbs.
03-10943M04	M2.5 x 8 Taptite Slit Torx® Pan Hd	Logic Heatsink Device Mount	2	T8	6-8 in.-lbs.	4-6 in.-lbs.
03-10943M09	M3 x 6 Taptite Slit Torx® Pan Hd	RF Board Mount Logic Board Mount Chassis Feedthru Plt Front Panel Filter Board	7 6 2 2	T10	8-10 in.-lbs.	6-8 in.-lbs.
03-10943M10	M3 x 8 Taptite Slit Torx® Pan Hd	PA Device / Board Mount Logic Heatsink to Chassis	8 2	T10	11-13 in.-lbs.	8-10 in.-lbs.
03-10943M11	M3 x 10 Taptite Slit Torx® Pan Hd	Power Connector Device to Logic Heatsink	2 2	T10	9-11 in.-lbs.	7-9 in.-lbs.
03-10943R55	M3 x 8 Taptite Torx® Flt Hd Blk	Chassis Covers	4	T10	8-10 in.-lbs.	6-8 in.-lbs.
02-00007003	Hex Nut 8-32	PA - Stud Device Mount	1	5/16" Hex	5 in.-lbs.	5 in.-lbs.
04-00136334	Flat Washer	Device to Logic Heatsink Power Connector	2 2	-- --	-- --	-- --
04-80943V01	Washer-Lock 3/8 Ext., Stl. Zinc	Antenna Connector	1	--	--	--
09-80131M01	3/8 Nut	Antenna Connector	1	3/8" Hex	18-20 in.-lbs.	18-20 in.-lbs.
38-80041M01	Plug, button	Heatsink Plug	1	--	--	--
03-11994A23	5-20 x 7/8" Plastite Phl Pan Hd	Mic. Rear Housing to Front Housing	3	1	9-11 in.-lbs.	9-11 in.-lbs.



## Alignment

## Alignment

The advanced design and manufacturing procedures eliminate the need for traditional tuning tasks.

All the circuits in the GM300 radio have been aligned at the factory with specialized equipment.

Alignment in the field should not be attempted or necessary.

## Programming

The GM300 radios can be programmed in the field to these parameters:

- Receive and transmit frequencies
- Transmit Frequency Adjustment (warp)
- PL or DPL encode and decode Codes
- Transmit Power Output
- Transmit Deviation
- Time Out Timer

Configuration information for programming these parameters is contained in the GM300 RADIO SERVICE SOFTWARE package HVN8177 Version B04.03.00 (or later versions) for 5.25 inch drives and 3.5 inch drive diskettes must be used.

A personal computer (P.C.) and the appropriate software diskette will be required in addition to the items listed in Recommended Test Equipment.

We strongly suggest the servicer become familiar with the programming techniques applicable to the GM300 radios.

## Recommended Test Equipment

R2001D: Communication Systems Analyzer

or

R2200B: Service Monitor

R1011B: Power Supply

R1037A: Digital Multimeter

or

R1024B: Digital Multimeter

## Board Replacement and Calibration

Replacement of the Logic board, RF board, or Power Amplifier requires that recalibration must be performed with the Motorola Radio Service Software. **The procedures for calibration are covered in the GM300 Radio Service Software Manual.**

Failure to perform the required calibration procedure will affect the performance of the Reference Oscillator, RF Power Leveling and Protection, and Transmitter Modulation over frequency and temperature. An uncalibrated radio may not comply with your Local Communications Agency rules and may be unreliable at temperature extremes.

The GM300 radio was designed to be serviced at the board level only. There are a number of non-field serviceable parts in the radio. Field replacement of these parts will affect the factory calibrated numbers on the tuning label. If any of these parts fail, board replacement is the only way to service the radio.

*Table 1-2. Error Tones*

Tone	Problem
1. High pitch Beep (900Hz 119ms) on initial turn on or when key is pressed.	1. Normal operation - no error.
2. Low pitched tone (163Hz) for 5 seconds following turn on.	2. Code plug error. For all code plug errors try to re-program radio. If this does not clear the fault or if problem recurs, replace the logic board
3. Low frequency (163Hz) continuous tone present whenever radio is on.	3. Logic board failure. Replace logic board.
4. Low pitch beep (300Hz 200 MS) when a button is pressed.	4. Button is not allowed in the current operating condition. Change operating condition (select another mode, etc.)
5. Low frequency (150Hz or 112.5Hz) continuous tone while PTT is held.	5. Transmit is not allowed. If it was time-out-timer, you may release PTT then continue your call.

# Theory of Operation

## RF Board

### VHF Receiver Front End, 146-174 MHz

The received signal applied to the radio's antenna input connector is first routed through the harmonic filter/antenna switch on the RF Power Amplifier Board, and then applied via coax to J4 on the RF Board. The insertion loss of the harmonic filter/antenna switch is less than 1 dB.

The signal applied to J4 is routed to a fixed-tuned 4-pole filter having a 3 dB bandwidth of 57 MHz and a 1 dB bandwidth of 37 MHz centered at 160 MHz. Insertion loss is 1.5 dB typically, and 2 dB at 146 MHz. Attenuation for image protection is 32 dB at 236 MHz, with increasing attenuation at higher frequencies.

The output of the filter is matched to the base of RF amplifier Q1, which provides 12 dB of gain and has a noise figure of 3.6 dB. Current source Q2 is used to maintain the collector current of Q1 constant at 26 mA. Diode CR2 clamps excessive input signals, protecting Q1.

The output of Q1 is applied to a 3-pole fixed-tuned filter having a 3 dB bandwidth of 59 MHz and a 1 dB bandwidth of 48 MHz centered at 160 MHz. Insertion loss is 1.3 dB. Attenuation for image protection is 35 dB at 236 MHz, with increasing attenuation at higher frequencies. Additional image protection is provided by the transmitter harmonic filter, which provides at least 20 dB of attenuation at 236 MHz and above.

A pin diode attenuator is located between the 3-pole filter and the first mixer. In the Distance mode, Q5 and Q6 are turned on, CR5 is forward-biased which bypasses R12, and no loss is introduced. In the Local mode, Q5, Q6 and CR5 are off, inserting 10 dB of attenuation due to R12. Because the attenuator is located after the RF amplifier, receiver sensitivity is reduced only by 5 dB, while the overall third order input intercept is raised by 15 dB. Thus, the Local mode significantly reduces the susceptibility to IM-related interference.

The first mixer is a passive, double-balanced type consisting of T1, T2 and U1. This mixer provides all of the necessary rejection of the half-IF spurious response, since the improvement due to filter selectivity is negligible for much of the band. High-side injection at

+13 dBm is delivered to the first mixer from the second RX buffer in the synthesizer circuit.

The mixer output is connected to a diplexer network which matches its output to the first IF amplifier Q51 at the IF frequency of 45.1 MHz, and terminates it in a 50 ohm resistor, R51, at all other frequencies.

### UHF Receiver Front End

The received signal applied to the radio's antenna input connector is first routed through the harmonic filter/antenna switch on the RF Power Amplifier Board, and then applied via coax to J4 on the RF Board. The insertion loss of the harmonic filter/antenna switch is less than 1 dB.

The signal applied to J4 is routed to a fixed-tuned 3-pole shunt resonator filter having the following characteristics:

Range	403-433	438-470	465-495	490-520
1 dB BW:	41 MHz	45 MHz	40 MHz	40 MHz
3 dB BW:	77 MHz	65 MHz	60 MHz	55 MHz
Loss:	3 dB	1.8 dB	2.2 dB	2.2 dB
$f_{\text{CENTER}}$ :	418 MHz	455 MHz	480 MHz	510 MHz
Image Rej:	33 dB	30 dB	35 dB	37 dB
At $f_{\text{IMAGE}}$ :	343 MHz	380 MHz	405 MHz	430 MHz

Attenuation for image protection increases for frequencies lower than  $f_{\text{IMAGE}}$ .

The output of the filter is matched to the base of RF amplifier Q1. Current source Q2 is used to maintain the collector current of Q1 constant at 30 mA. Transistors Q3 and Q4 turn off the DC supply to Q1 and Q2 during transmit, reducing the dissipation in Q1. Diodes CR2 and CR3 clamp excessive input signals, protecting Q1. The RF amplifier parameters are:

Range	403-433	438-470	465-495	490-520
Gain:	16 dB	15 dB	15 dB	15 dB
N.F.:	1.4 dB	1.4 dB	1.8 dB	1.8 dB

The output of Q1 is applied to a tunable 4 pole shunt resonator filter with these characteristics:

## RF Board

Range	403-433	438-470	465-495	490-520
1 dB BW:	35 MHz	45 MHz	40 MHz	40 MHz
3 dB BW:	44 MHz	60 MHz	60 MHz	55 MHz
Loss:	4.2 dB	3.7 dB	3.8 dB	3.8 dB
$f_{\text{CENTER}}$ :	418 MHz	455 MHz	480 MHz	510 MHz
Image Rej:	55 dB	40 dB	52 dB	54 dB
At $f_{\text{IMAGE}}$ :	343 MHz	380 MHz	405 MHz	430 MHz

Again, image attenuation increases for frequencies lower than  $f_{\text{IMAGE}}$ .

A pin diode attenuator is located between the 4 pole filter and the first mixer. In the Distance mode, Q5 and Q6 are turned on, CR5 is forward-biased which bypasses R12, and no loss is introduced. In the Local mode, Q5, Q6 and CR5 are off, inserting 10 dB of attenuation due to R12. Because the attenuator is located after the RF amplifier, receiver sensitivity is reduced only by 5 dB, while the overall third order input intercept is raised by 15 dB. Thus, the Local mode significantly reduces the susceptibility to IM-related interference.

The first mixer is a passive, double-balanced type consisting of T1, T2 and U1. This mixer provides all of the necessary rejection of the half-IF spurious response, since the improvement due to filter selectivity is negligible at 470 MHz. Low-side injection is delivered to the first mixer from the second RX buffer in the synthesizer circuit. The injection level is +11.6 dBm for 403-433 range, +5 dBm for the 438-470 MHz range, and +6.5 dBm for the 465-495 and 490-520 MHz ranges.

The mixer output is connected to a diplexer network which matches its output to the first IF amplifier Q51 at the IF frequency of 45.1 MHz, and terminates it in a 50 ohm resistor, R51, at all other frequencies.

## Receiver Back End

Q51 amplifies the IF signal by approximately 17 dB. The output of Q51 is filtered by a four pole crystal filter (comprised of two matched units Y51A and Y51B). The 3 dB bandwidth of the crystal filter is 14 kHz for 20/25 kHz channel spacing models, and 8 kHz for 12.5 kHz channel spacing models. The signal is amplified 18 dB by the second IF amplifier Q52, and applied to the input of the receiver system IC U51-19 (see Figure 2-1).

The 45.1 MHz first IF signal is applied to the second mixer section of U51. A 44.645 MHz crystal oscillator provides the low side injection signal, which is also applied to U51-19. The output of the second mixer is a 455 kHz second IF signal which is filtered by ceramic filter FL51, amplified, filtered by ceramic filter FL52, and applied to the audio detector. As with the crystal filter, the bandwidth of the ceramic filters are narrower for 12.5 kHz channel spacing models than for 20/25 kHz. The IF test point is located at the output of filter FL52. The level of the 455 kHz signal at this test

point is linearly related to the input signal level at the antenna, allowing a convenient metering point for filter tuning and gain measurements.

The audio detector is a peak-differential type, with the necessary phase shift (90° at 455 KHz) provided by L-C network L61. Recovered audio from U51-5 is routed to the receiver audio circuitry on the logic board, and to the squelch circuitry contained in U51. When an on-channel signal is present, the amount of high-frequency audio noise at the detector output is reduced. This change in noise level is sensed to indicate the presence of an on-channel signal. Audio noise at U51-5 is applied to U51-7 via R61 and C82. Extreme high-frequency noise is removed by C81. The noise is amplified and appears at U51-6 where it is coupled via C80 to the SQUELCH adjust pot R60. The output of this control is applied via R59, C79 and C78 to pin 8 which is the input of a limiting amplifier and threshold detector.

Noise levels greater than a preset threshold cause U51-11 to go high. This is buffered by Q53 and routed to the microcomputer circuitry on the logic board. This corresponds to no channel activity. When the noise level decreases below the threshold, due to on-channel quieting, U51-11 goes low, providing a low to the logic circuitry. This implies an on-channel signal is present, causing unmuting of the receive audio path by the microcomputer.

Components R58, C75 and C76 determine squelch time constants as a function of the charging currents supplied by U51. These charging currents vary from weak to strong signal conditions, providing a variable squelch closing time-constant. For weak signals the time constant is long to minimize "chattering" or rapid muting and unmuting of the audio. For strong signals, where the carrier-absent to carrier-present conditions are substantial, the closing time-constant is shortened to minimize the length of the "squelch-tail".

## Frequency Synthesizer

To determine the synthesizer's operating frequency, the microcomputer loads the frequency divider information into the PLL IC U101 (see Figure 2-2). The PLL IC contains three programmable dividers. The program is serially loaded via the SR DATA line to U101-10. The data is loaded one bit at a time, with each low-to-high transition of the SR CLOCK at U101-11 latching data from shift registers into the reference divider (R), divide-by-N, or divide-by-A latches depending on the control bit. A logic high of the control bit selects the reference counter latch, while a logic low selects the divide-by-N, or divide-by-A counter latch.

After the microcomputer loads data into the PLL IC, the SYNTH LATCH ENABLE line goes low. The synthesizer is then ready to generate a receive first-injection or transmit frequency.

*Figure 2-1. Receiver IC Block Diagram*

In UHF radios, for example, the latches are loaded with data to give 5 kHz (or 6.25 kHz) at the output of the divide-by-R counter when the reference signal is applied at U101-1, and 5 kHz (or 6.25 kHz) at the output of the divide-by-N counter when the VCO is operating at the desired receive injection or transmit frequency.

During the frequency synthesis, the divide-by-A and divide-by-N counters begin counting down from the programmed values (A and N respectively) at the same time. The modulus control line U101-12 is low so the divide-by-127/128 prescaler divides by 128. Therefore, the effect of the prescaler U102 is to divide the VCO output by 128 and apply it to U102-8. When the divide-by-A counter completes counting down, the control logic sets the modulus control line high, and the divide-by-127/128 prescaler divides by 127 until the divide-by-N counter completes the programmed value on N. After the divide-by-N counter completes counting down, the counters are set back to their programmed values. The effect of the prescaler and divide-by-A, divide-by-N counters is to divide the VCO frequency by a number, N, where:

$$N = 128 \times A + 127 \times (N-A) = 127 \times N + A$$

The output of the divide-by-N counter is equal to:

$$f_{VCO} / (127 \times N + A)$$

When the phase-locked loop is locked:

$$f_{VCO} / (127 \times N + A) = 5 \text{ kHz} = f_{VCO} / N^T$$

The reference oscillator frequency is 14.4 MHz and the output of the divide-by-R must be 5 kHz. Therefore:

$$R = 14.4 \text{ MHz} / 5 \text{ kHz}$$

The values of A and N are dependent on the desired VCO frequency which is equal to the transmit frequency, or to the receive frequency minus 45.1 MHz (for UHF radios).

$$N = \text{integer part of } N_T / 127$$

$$A = \text{remainder of } N_T / 127$$

The 5 kHz outputs of the divide-by-A and divide-by-N counters are applied to phase detector A. The output of

*Figure 2-2. Synthesizer Section Block Diagram*

phase detector A is applied to phase detector B. There are two output signals for phase detector B, phase R (U101-16) and phase V (U101-15), which consist of pulses whose pulse width depends on the phase error between the two signals at phase detector A. If the frequency  $f_V$  is greater than  $f_R$ , then error information is provided by phase V pulsing low, while phase R remains essentially high. When  $f_V$  and  $f_R$  are both in phase, both phase V and phase R remain high, except for a small minimum time period, and they both pulse low in phase. These pulses are applied to the charge pump and are used to correct (steer) the VCO frequency.

The above discussion is for a UHF radio with a 5 kHz reference frequency. VHF radios use a divide-by-64/65 prescaler, and the receive VCO frequency is equal to the receive frequency plus 45.1 MHz. Either a 5 or 6.25 kHz reference frequency may be used depending on the desired frequencies and channel spacing.

When the synthesizer is locked, U101-7 applies a high level signal with very narrow negative-going pulses to the out-of-lock detector. The very narrow low pulses have a high average DC level that is not sufficient to turn on transistor Q101. This keeps the voltage across C102 low, which indicates an in-lock condition.

When the synthesizer is out-of-lock, the output of U101-7 becomes a pulsating DC signal with an average DC level that varies between 0.5V and 4.4V. This turns on Q101 and charges C102 to at least 3.0 volts, indicating an out-of-lock condition. Transmitter output and receiver audio are inhibited under these circumstances.

The 5V DC operating voltage for the synthesizer and prescaler is derived from a voltage divider buffered by Q106. Due to the low and relatively constant current drain requirements, a more elaborate regulator is unnecessary.

### Charge Pump

The charge pump consists of Q102-Q105. The phase V (U101-15) signal from the PLL IC is applied to Q103 while phase R (U101-16) is applied to Q102. Then the synthesizer is locked, both signals consist of a pulse train with a period of 160 or 200 usec and negative-going pulses. The phase R negative pulse turns off Q102 and brings the emitter of Q104 to 9.6V which turns on Q104. The negative pulse of phase V turns Q103 off which reduces the current flow to R114 and in turn reduces the voltage across R114. This will cause Q105 to turn on and sink current from Q104.

When the synthesizer reaches lock, the voltage at the steering line will be between 1.3V and 7.8 V DC. When the synthesizer is reprogrammed to a new frequency, the previous SL voltage would now give a wrong frequency and will cause the phase R and phase V to have different pulse widths. This will cause Q104 and Q105 to turn on and off at different times, resulting in a series

of summed current pulses to the loop filter that charges or discharges C110 to the new SL voltage. If the frequency of the VCO is higher than that of phase R, then C110 discharges; if lower, C110 charges.

### Loop Filter

The loop filter consists of R119 through R121 and C109 through C112, as well as C205 and C258 in the VCO compartment. The loop filter is a low pass filter that attenuates noise and rejects the loop reference frequency so that these signals cannot modulate the VCO. The voltage across C110 is the steering line voltage which controls the VCO frequency.

### Reference Oscillator

The reference oscillator is a Colpitts design using a 14.4 MHz crystal element. Each crystal has a unique 8-digit temperature coefficient code which must be keyed into the radio during chassis auto tune. The reference oscillator is warped to the desired range by adjusting L151 while supplying  $5.2 \pm 0.01V$  DC at J6-9. Further frequency warp adjustment is done electronically by changing the control voltage applied to varactors CR151 and CR152 by the logic board.

Temperature compensation is applied in the same manner, based on the temperature of the crystal as sensed by zener diode VR176, which is physically close to Y151. The forward voltage drop of this diode is proportional to the actual crystal temperature. This forward voltage is amplified by a precision DC amplifier, U176 and associated components, to a DC level sufficient to be read by one of the A/D inputs of the microcomputer on the logic board. The appropriate control voltage is applied, based on the crystal's temperature coefficient code, to maintain  $\pm 2.5$  ppm stability over the entire operating temperature range.

For transmissions of PL/DPL or data with low-frequency content, the reference oscillator is modulated to extend the low frequency modulation capability of the synthesizer below the loop filter cutoff frequency. Modulation is applied to the frequency control varactors CR151 and CR152 via J6-13 and REF MOD adjust pot R164.

### VCO's and Buffers

Two VCO's are used, one for transmit and one for receive. These are selected by switching circuitry Q277 through Q279, which applies 8.5V DC supply voltage to the appropriate oscillator and buffers. The incoming 9.6V DC voltage is first filtered by Q276 to remove noise which might be introduced into the VCO's. Q276 acts as a C-multiplier, which effectively multiplies the capacitance of C277 by the gain of transistor Q276. In the receive mode, J6-4 is pulled high by R276, turning off Q277 and Q278, allowing Q279 to conduct and supply RX 8.5V. In the transmit mode, J6-4 is pulled low by

## Logic Board

the logic board. Q277 conducts to supply TX 8.5V, and Q278 saturates across the base-emitter of Q279, turning it off.

Each VCO consists of a FET oscillator whose frequency is determined by a parallel L-C network consisting of a tunable coil and a network of varactors. As the steering line varies over the range of 2V to 7.8V DC, the capacitance of the varactors decreases as voltage is raised, causing the oscillator frequency to increase. The transmit VCO has an additional varactor, CR208, which is very lightly coupled to the tank circuit, which provides frequency modulation of the VCO from the audio signal applied at J6-10 and adjusted by VCO MOD adjust pot R302.

Each VCO has an AGC rectifier circuit (CR206 or CR214) which varies the DC gate bias on the VCO FET as a function of the RF output level at the VCO's drain. This helps maintain a more constant VCO output level, and prevents RF voltages from increasing to levels which might cause rectification by the varactors.

Transistors Q204, Q205 are receive buffer amplifiers. These raise the RF output of the VCO to the level required as injection for the first mixer, typically between +5 and +13 dBm depending on the frequency band, as detailed in sections 1.1 and 1.2. The RF at Q205's base is sampled and fed back to the synthesizer via buffer Q107, allowing the synthesizer to "know" if the VCO is operating at the correct frequency.

Similarly, transistors Q207, Q208 are transmit buffer amplifiers. These raise the RF output of the VCO to the level required by the RF power amplifier, typically +13 to +14.5 dBm, as measured at J5, which is a 50 ohm port. The VCO frequency is sampled at Q208's base and fed back to the synthesizer via buffer Q107.

## Logic Board

There are two versions of logic boards used in GM300 series mobile radios, "masked" and "expanded." The expanded logic board has a shielded compartment which encloses the microcomputer, custom gate array, and external memory IC's, and has a four-layer printed circuit board layout. The masked logic board uses a two-layer circuit board without the shielded compartment, with all software functions contained in a single masked microcomputer IC. In general, the masked logic board is used in 2 and 8 channel models with basic signaling capabilities, while the expanded logic board is found in 16 channel models having more elaborate signaling systems or requiring programmable accessory connector I/O's.

The logic board circuitry consists of five major sections:

- DC distribution and regulation
- Microcomputer and logic

- Receiver audio circuitry
- Transmitter audio circuitry
- Transmitter power control circuitry

## DC Distribution and Regulation

All operating voltage for the radio is supplied from the RF power amplifier's battery input connector J2. This voltage is protected from reverse polarity or excessive positive transients by CR2270, CR2370, CR2470, CR2570, CR2670 or CR2770 (depending on power amplifier kit), which acts as a power diode for reverse polarity protection, as well as a power transient suppressor due to its reverse avalanche characteristics. The supply voltage is routed to the logic board via J7-5 (UNSW B+).

Whenever UNSW B+ is supplied, a continuous source of 5V DC is applied to pin 2 of the microcomputer from the RAM 5V supply (VR402, CR403, R410 and C408). This maintains the radio's scan list, current operating mode, etc., when the radio is turned off. Due to the storage of C408, this information can be maintained for up to several hours even if the battery supply voltage is interrupted.

When ignition control is not used, UNSW B+ via fuse F801 becomes B+ which is routed through the on-off switch to become SW B+. When ignition control is used, fuse F801 is removed, and the vehicle's ignition-switched voltage is supplied to J3-10 which is the B+ that is routed through the on-off switch to become SW B+. Thus, with ignition control, ignition-controlled voltage must be present at J3-10 for the radio to operate.

In 2-layer masked logic boards, when the radio is turned on, SW B+ turns on Q404 via R414, which then turns on Q403 via R412. When Q403 is on, UNSW B+ is applied to the supply pins of opamps U401 and U451 (energizing the 9.6 volt regulator and transmitter power control circuits). The low saturation voltage of Q403 keeps the supply voltage of the transmitter power control circuit essentially equal to the UNSW B+ voltage present in the RF Power Amplifier. This is important for accurate power control operation. SW B+ is also routed to 5 volt regulator U402 (powering the microcomputer and logic circuitry) and to J3-13, the SW A+ sense pin on the accessory connector. The current drawn through the on-off switch is relatively low, less than 400 mA, and the majority is that required by the 5V regulator. All high current stages, such as the RF and audio power amplifiers, operate from UNSW B+ and are controlled by low currents.

In 4-layer expanded logic boards, power distribution is similar except that Q403 also switches the supply voltage to the 5 volt regulator IC U402. The higher current drain from the 5V regulator due to the expanded logic circuitry does not need to flow through the radio's on-

off switch in this case. However, in 4-layer boards Q403 is a TMOS device, which exhibits very low on-resistance (less than 0.6 ohm) and therefore negligible voltage drop, without requiring large base current flow to saturate it.

The 9.6V regulator uses an opamp as a controlling element. The regulated output voltage is divided by R404 and R405 and compared with an accurate reference voltage (5.03V DC) determined by VR401. The opamp's output voltage (U401A-1) varies the amount of conduction in Q402 and Q401 as necessary to keep these two voltages (U401A-2 and -3) equal. A characteristic of the opamp which allows the regulator to start up is the fact that the output is high when both inputs are low, which occurs momentarily at turn-on. Diode CR401 is used to protect Q401 if the 9.6V line is grounded. When this happens, Q402's base can only be 0.7V DC and Q401 will be turned off. Diode CR402 provides temperature compensation of the regulated output voltage. The 9.6V supply powers the opamps in the receive and transmit audio circuits, the D/A converter, the RF board circuitry, and low level stages of the RF power amplifier.

The 4.8V DC reference is formed by divider R408-R409, filtered by C405, and buffered by unity gain opamp U401B to provide a low-impedance and low noise half-supply reference voltage for the opamps in the audio circuits.

The 5V regulator uses an IC, U402, to provide operating voltage for the microcomputer and logic circuits and the front panel LED displays. This IC generates a low reset pulse when turned on which is used to initialize the microcomputer at power-up. The timing of this pulse is determined by C409.

### **Microcomputer and Logic**

GM300 radios use the Motorola 68HC11E9 microcomputer, U802, which utilizes:

- 7.776 MHz clock rate
- Multiplexed 8 bit address/data lines
- 16 bit addressing
- Internal watchdog circuitry
- Analog to digital conversion input ports

Additional control logic surrounding U802 consists of:

1. D/A CONVERTER U801. This IC is used to generate precision analog voltages for transmitter power control, deviation adjustment, and reference oscillator frequency warp.
2. CUSTOM GATE ARRAY U803. This device expands the input/output capabilities of the control logic. U802 and U803 exchange infor-

mation which tells the microcomputer the input port status and the desired state of the output ports. Used in expanded logic boards only.

3. EPROM U804. This is an Erasable Programmable Read Only Memory, whose function is to store the microcomputer's operating program. Used in expanded logic boards only.
4. EEPROM U805. This is an Erasable Programmable Read Only Memory, which acts as the radio's code plug. It supplements the capability of the EEPROM contained within U802, storing additional operating information pertinent to a particular radio, such as operating frequencies, signaling codes, scan lists, time-out timer, programmable I/O assignments, and other special functions. Used in expanded logic boards only.
5. SRAM U806. This Static Random Access Memory is used for "scratch pad" operations. Used in expanded logic boards only.

In masked logic boards, the microcomputer's operating program is permanently written or "masked" within the microcomputer. Included in U802 is an EEPROM memory which stores channel, signaling, and scan list information, similar in function to U805 but with less storage capability.

### **Microcomputer Start-Up Routine**

The microcomputer is operational after the RESET line is released by U402 at turn-on. Y801, the crystal oscillator, should be stable at this point. Y801's frequency is divided by four by U802 to produce the E-CLOCK (1.944 MHz, at U802-5) which is the data clock for microcomputer and, in expanded logic boards, gate array U803. The microcomputer then executes a self-test routine and generates an error tone if a failure is detected. Q807 shifts the crystal frequency very slightly by introducing network L801/C831 when Q807 is off. This can be used to remove an on-channel self-quieting signal which is a harmonic of the crystal, if necessary.

### **Microcomputer Operation-Expanded Logic**

In expanded logic boards, a successful self test of the control logic will activate the multiplexed address/data bus. The microcomputer has an eight bit address/data bus and an eight bit address-only bus. These bus lines are connected to gate array U803 for I/O port information, and to the external memory IC's to send and receive information.

The custom gate array must de-multiplex the lower order address byte from the address/data bus (AD0-AD7) in order to address a particular function or memory location.



## Logic Board

The microcomputer puts the address information on AD0-AD7 and the information is then passed to U803. The address strobe "AS" is pulsed low and the byte is latched. The de-multiplexed address byte A0-A7 is then available on U803. The bus is now ready for the transmission of data. The higher order address byte A8-A15 is not multiplexed and is readily available at the microcomputer U802.

### Reading or Writing in Memory-Expanded Logic

In expanded logic boards, the specified memory IC must first be enabled before a read/write operation can take place. Each memory IC has its own chip select line. EPROM SEL originates at U803-13, EEPROM SEL at U803-14, and SRAM SEL at U803-15. The lines are normally logic high; a specific IC is selected when the appropriate line is pulsed low.

The R/W line from U803-16 determines if data is being read (logic high) or written (logic low). EPROM U804 is a read-only memory and does not require a R/W input.

The output enable line "OE", when pulsed low, will enable the tri-state output gates to pass the contents of the desired address out onto the A/D bus.

### Programmable I/O's

In masked logic boards, the function of J3-14 is programmable by the placement of push-on jumper JU809. In the "REMOTE" position, J3-14 provides the hook function for a remote desk set. When pulled low, the radio is forced "off-hook" or into a monitor condition. In the "PA" position, J3-14 provides the public address enable function; when pulled low, transmitter PTT is inhibited.

In expanded logic boards, pins 8, 12 and 14 are software-programmable I/O's, pins 6 and 9 are software-programmable inputs, and pin 4 is a software-programmable output. If, for example, J3-14 is used as an input, U803-39 will be logic low, keeping Q814 off. When an accessory pulls J3-14 low, Q813 will turn off, and the resulting logic high at its collector will be read by U803-24. If J3-14 is programmed as an output, the signal provided by U803-39 will turn Q814 on or off as needed, supplying either an active low or a logic high (pulled up by R901, 4.7k) to the accessory. By moving JU808 from its normal PROG I/O position to the SCI+ position, J3-12 can be used as an SCI programming line, electrically connected via J8-9 to the SCI+ pin on the microphone connector (pin 7).

## Receiver Audio

### Voice Path

Detector audio from the RF board is routed via J6-3 to U551A. A series resistor on the RF board, R62, is chosen

to provide an additional 6 dB of receiver audio gain in 12.5 kHz channel spacing models, where full system deviation is one half of that used for 25/30 kHz channel spacing. The gain of U551A is chosen so that supply-rail limiting occurs at 20% above full system deviation. This limits the amplitude of impulse-type ignition noise. Noise above 3 kHz is attenuated by a 3-pole low pass filter (U551B) whose Bessel-Thompson characteristic is chosen to minimize ringing due to impulse-type noise. Following is a 5-pole biquadratic 300 Hz high-pass filter (U552A and B) which attenuates subaudible signaling tones such as PL and DPL. This is followed by de-emphasis amplifier U553A, mute gate Q551 and summing amplifier U553B which combines the receive audio signal with alert tones generated by the microcomputer at U802-29 and filtered by C566 and C567. The output of U553B is routed to the volume control via J8-1, from the volume control via J8-2 to the input of the audio power amplifier, U501.

The audio power amplifier is a BTL (bridge-tied load) configuration providing 7.5 watts rms into an external 8 ohm speaker. Both sides of the speaker are driven with out-of-phase signals, therefore neither side of the speaker can be grounded. The outputs are internally protected against accidental short circuits to supply or ground. The internal speaker has a 22 ohm impedance which limits the power delivered to it to 3 watts, which is within its rating. The audio power amplifier is turned on when a sense voltage greater than 8 volts DC is applied to pin 8. This is obtained from SW B+ via R501. When no audio output is required, U501 is turned off by saturating transistor Q501, providing 0 volts to U451 pin 8. This allows muting of the audio power amplifier. When the radio is turned off, SW B+ is not present, so there is no source of voltage to pin 8 via R501, keeping U501 off. When muted (pin 8 low), U501 draws no current from the UNSW B+ source. Capacitor C504 controls the turn on and turn off timing of the power amplifier to minimize transients. C501 and C502 provide low and high frequency filtering respectively.

When any front panel button is pressed, a beep is heard in the speaker. This is produced by the microcomputer-generated alert tone applied to stage U553B, as discussed above. U501 is enabled by turning off Q501, however mute gate Q551 remains muted so that the beep is heard but noise or signals from the receiver are not. Alert tones are also used by various signaling systems, or for error tones during self-test.

Receiver audio is available at the accessory connector J3-11. Depending on the position of push-on jumper JU551, audio may be either de-emphasized, filtered and muted, derived from the output of U553B, or flat and unmuted, derived from the output of U551A in masked logic boards or from buffer U651B in expanded logic boards.

## Data Path

Receiver audio is also used for decoding of signaling tones or codes. There are two general classifications of the types of data involved. High-speed data refers to data which occupies the voice range of frequencies (between 300 and 3000 Hz, although it can also occupy the entire range from less than 1 Hz to 3000 Hz). This data is not transmitted simultaneously with voice. The other type is low-speed data, which is contained to frequencies below 300 Hz, generally at reduced deviation levels, and may be transmitted simultaneously with voice. MDC1200 and Select 5 are examples of high-speed data; PL and DPL are examples of low-speed data.

Low speed data is obtained from U551B-7, which contains frequencies between 0.6 Hz and 3000 Hz. It is buffered by U602A and filtered by U603A and U603B in masked logic boards, or U602B and U603A in expanded logic boards. These form a 5-pole biquadratic low pass filter, attenuating all signals above 250 Hz. This filter prevents voice from interfering with low-speed data detection. This is fed to a center-slicer (U601B in masked, U603B in expanded) which converts the tone or data into a symmetrical square wave which can be decoded by the microcomputer. The center slicer tracks out near-DC offsets to maintain waveform symmetry. In expanded boards, U603B is an opamp rather than a comparator, and transistor Q601 is used to provide level shifting to a 0-to-5V logic level.

High speed data can be obtained from either U551B-7, the same point as for low-speed data, or from U552B-7, which only contains frequencies between 300 and 3000 Hz. If the type of data does not contain information below 300 Hz, the use of additional 300 Hz high-pass filtering improves detector sensitivity. No additional filtering is required, only that the signal is squared up by center-slicer U601A before being applied to the microcomputer for decoding.

## Transmitter Audio

### Voice Path

Microphone audio is routed from the front panel mic jack via J8-14, or from accessory connector J3-2, to the mic mute gate Q651. DC bias is applied to operate the transistor amplifier within the microphone. Q651 is controlled by Q652 and mutes the microphone audio path during receive mode or during transmission of high-speed signaling or data. When low mic gain (80 mV rms for 60% deviation) is selected by JU651, the signal is pre-emphasized by C652 and R655; for high-gain (40 mV rms), by C667 and R647. Supply rail limiting by U651A prevents over-deviation.

The signal is then routed to the RF board reference oscillator modulation input via J6-13, and, via buffer U652A, to voltage controlled attenuator U652. Devia-

tion is adjusted by programming the DC output voltage of D/A converter U801-6. This allows electronic adjustment of deviation, compensation for sensitivity variations across the operating frequency band, and choice of full system voice deviation on non-PL or DPL channels, or reduced voice deviation on channels with PL or DPL. The output of attenuator U653 is routed through U652B, a 3-pole biquadratic 3000 Hz low-pass "splatter" filter, before being applied to the RF board as VCO modulation via J6-10.

Radios used in 12.5 kHz channel spacing systems require full deviation of 2.5 kHz, instead of 5 kHz for 25/30 kHz systems. This reduction is accomplished by resistor values on the RF board surrounding the VCO MOD and REF MOD adjust posts.

### Data Path

High speed data is generated by microcomputer outputs U802-30 and 31 which are summed by opamp U602B (masked) or U701A (expanded). The ratio of R701 and R702, and the relative timing of the transitions of the two microcomputer outputs, allow low-distortion simulated sinewaves to be generated. The opamp output is routed to the input of limiter U651A, where it is summed with pre-emphasized mic audio. The audio path from U651A to the limiter is not pre-emphasized. The remainder of the audio path to the modulator is the same as for the voice signal path.

In masked logic boards, audio applied to accessory connector J3-5 is applied, without pre-emphasis, to the input of the limiter U651A. In expanded logic boards, jumper JU701 allows either this path to be chosen (position "A"), or allows J3-5 audio to be routed via low-speed data filter U701B (JU701 in position "B") and introduced into the transmitter audio path after the limiter. In this configuration, externally-generated PL may be applied to the transmitter without being "captured" (attenuated or removed entirely) when limiting due to voice peaks occurs.

Low speed data is generated by microcomputer outputs U802-27 and 28 which are summed by opamp U651B (masked) or U701B (expanded). The ratio of R706 and R707 allow low-distortion simulated sinewaves to be generated. The opamp is configured as a 3-pole biquadratic low pass filter to remove any distortion components of the low speed data signal above 300 Hz which would fall within the voice range. This audio is resistively summed with the output of the limiter U651A. In this manner, limiting on voice peaks will not affect the continuous low speed data transmission. The summed audio is then routed to the REF MOD input of the RF board via J6-13, and to the voltage controlled attenuator, splatter filter, and VCO MOD input of the RF board (J6-10), following the same path as voice signals.

## Transmitter Power Control

### Control Line Functions

As discussed earlier, all DC operating voltage for the radio originates from the RF power amplifier via J7-5 (UNSW B+). In addition, J7 receives DC control voltages from, and supplied DC control voltages to, the RF power amplifier circuitry.

In the transmit mode, Q455 conducts, supplying 9.6T (keyed 9.6V DC) via J7-1 to the antenna switch and providing bias (and collector voltage, in UHF models) for the first transmitter stage.

Controlled B+ is supplied via J7-2 to the collector of the first (VHF) or second (UHF) transmitter stage. As this voltage varies over the range of 3 to 12.5V DC, transmitter output power is varied over the range of 10 to 25 watts.

A small-value (.01 to 0.2 ohm) resistor is placed in series with the DC supply to the RF final amplifier, and the voltage across this resistor is measured via the current sense high (J7-3) and low (J7-4) lines.

The temperature of the final RF amplifier is monitored by a thermistor mounted next to it. The thermistor is part of a voltage divider network whose output voltage is routed, via J7-6, to an A/D input of the microcomputer, U802-49.

### Power Control Operation

Power level is programmed electronically during radio tune-up at the factory. The software varies the DC output voltages of D/A converters U801-2 and U801-4 (two D/A's are summed for increased resolution) and applied to the (+) input of opamp U451A. As D/A voltage increases, U451A-1 output voltage increases, which causes greater conduction in Q453 and Q452, thus increasing the control voltage and RF power output. The values of R810, R811, R462 and R463 reduce the D/A output voltage range (0 to 9V DC) to the required 4V to 6V DC range at U451A-3.

If the DC current of the final RF amplifier increases excessively due to, for example, an antenna system fault, the increased voltage drop across the series resistor will be sensed by U451B, causing the current through Q454 to increase until the two inputs of U451B are again equal (the collector resistor of Q454 is on the RF power amplifier board since its value is optimized for different power amplifiers). The increase in Q454 current raises its emitter voltage which is applied to the (-) input of U451A. This is in a direction to reduce the output voltage of U451A-1, reducing conduction in Q453 and Q452, lowering the controlled B+ voltage to counteract the excessive current condition.

Excessive RF final amplifier temperature causes an increase in the THERMAL DC voltage at U802-49. The

microcomputer reduces power via the D/A converter to achieve a safe equilibrium.

Under any circumstance, controlled B+ is prevented from exceeding a pre-programmed DC voltage. The voltage is divided by R471 and R472 and monitored by microcomputer A/D input U802-45 every 17 msec. If voltage exceeds the maximum allowable, the DAC is decremented one step, and this process is repeated as needed.

## RF Power Amplifiers

This manual covers several different power amplifier kits. Each is optimized for the specific frequency and power output range of the radio model in which it is used. All are similar in that they can be divided into three basic circuits:

- Power amplifier
- Antenna switch
- Harmonic filter

### 1-10 Watt VHF Power Amplifier

The 1-10 watt VHF power amplifier is designed to cover the range of 146-174 MHz. It consists of three stages. The first stage, Q2210, operates in Class A with its operating voltage supplied by the 9.6T source. It has a gain of 9 dB and delivers 160 mW of output power.

The second stage, Q2220, is operated in Class C and also has 9 dB of gain. The collector voltage is supplied from controlled B+. The output level of this stage is varied by changes in the controlled B+ voltage. This stage delivers up to 1.3 watts output.

The third stage, Q2230, is the Class C RF final power amplifier. It can output in excess of 14 watts. Collector current is monitored by the power control circuit by measuring the voltage drop across a 0.2 ohm resistor, R2274, placed in series with the collector DC supply lead.

The antenna switch consists of two pin diodes, CR2250 and CR2251. L2252 is parallel-resonant with the off capacitance of CR2250, increasing its attenuation when off. C2253 is a DC block.

In the receive mode, both diodes are off. Signals applied at the antenna jack J1 are routed, via the harmonic filter, through network L2251, C2251 and C2252 to the receiver input. In the transmit mode, 9.6T is present and both diodes are forward-biased into conduction. The transmitter RF from Q2230 is routed through CR2250, and via the harmonic filter to the antenna jack. CR2251 conducts, shunting RF power and preventing it from reaching the receiver. L2251 is selected to appear as a 1/4 wave at VHF, so that the low

impedance of CR2251 appears as a high impedance at the junction of CR2250 and the harmonic filter input.

The harmonic filter is a nine pole 0.1 dB ripple Chebyshev low pass filter with a 3 dB frequency of approximately 205 MHz and less than 1 dB insertion loss in the passband.

### **10-25 Watt VHF Power Amplifier**

The 10-25 watt VHF power amplifier is designed to cover the range of 146-174 MHz. It consists of three stages. The first stage, Q2310, operates in Class A with base bias supplied by the 9.6T source. The collector voltage is supplied from controlled B+. The output level of this stage is varied by changes in the controlled B+ voltage.

The second stage, Q2320, is operated in Class C. Collector voltage is supplied by UNSW B+. This stage delivers up to 3 watts output.

The third stage, Q2330, is the Class C RF final power amplifier. It can output in excess of 30 watts with 3 watts input power. Collector current is monitored by the power control circuit by measuring the voltage drop across a .05 ohm resistor, R2371, placed in series with the collector DC supply lead.

The antenna switch consists of two pin diodes, CR2350 and CR2351. L2353 is parallel-resonant with the off capacitance of CR2350, increasing its isolation when turned off. C2354 is a DC block. L2352 and C2352, combined with the "on" inductance of CR2351, form a series resonant circuit to lower the shunt impedance presented by CR2351 when it is turned on.

In the receive mode, both diodes are off. Signals applied at the antenna jack J1 are routed, via the harmonic filter, through network L2351, C2351 and C2353 to the receiver input. In the transmit mode, 9.6T is present and both diodes are forward-biased into conduction. The transmitter RF from Q2330 is routed through CR2350, and via the harmonic filter to the antenna jack. CR2351 conducts, shunting RF power and preventing it from reaching the receiver. L2351 is selected to appear as a 1/4 wave at VHF, so that the low impedance of CR2351 appears as a high impedance at the junction of CR2350 and the harmonic filter input.

The harmonic filter is a nine pole 0.1 dB ripple Chebyshev low pass filter with a 3 dB frequency of approximately 205 MHz and less than 1 dB insertion loss in the passband.

### **25-45 Watt VHF Power Amplifier**

The 25-45 watt VHF power amplifier is designed to cover the range of 146-174 MHz. It consists of four stages. The first stage, Q2410, operates in Class A with its operating voltage supplied by the 9.6T source. It

provides 11 dB of gain and has an output power of 250 mW.

The second stage, Q2320, is operated in Class C. The collector voltage is supplied from controlled B+. The output level of this stage is varied by changes in the controlled B+ voltage. It has a gain of 9.1 dB and provides up to 2 watts of output power.

The third stage, Q2430, also operates in Class C. The collector voltage is supplied directly from the UNSW B+ source. This stage has a gain of 8.8 dB and an output power of 15 watts. Feedback is used to control the gain and maintain stability.

The fourth stage, Q2440, is the Class C RF final power amplifier. It has a gain of 6 dB and can output in excess of 60 watts with 15 watts of input power. The power control circuit monitors this stage's collector current by measuring the voltage drop across a .01 ohm resistor, R2471, placed in series with the collector DC supply lead.

The antenna switch consists of two pin diodes, CR2450 and CR2451. L2453 and C2453, combined with the internal "on" inductance of CR2451, form a series resonant circuit to lower the shunt impedance presented by CR2451 when it is conducting.

In the receive mode, both diodes are off. Signals applied at the antenna jack J1 are routed, via the harmonic filter, through network L2452, C2454 and C2455 to the receiver input. In the transmit mode, 9.6T is present and both diodes are forward-biased into conduction. The transmitter RF from Q2440 is routed through CR2450, and via the harmonic filter to the antenna jack. CR2451 conducts, shunting RF power and preventing it from reaching the receiver. L2452 is selected to appear as a 1/4 wave at VHF, so that the low impedance of CR2451 appears as a high impedance at the junction of CR2450 and the harmonic filter input.

The harmonic filter is a seven pole 0.1 dB ripple Chebyshev low pass filter with a 3 dB frequency of approximately 200 MHz and a typical insertion loss of 0.8 dB in the passband.

### **1-10 Watt UHF Power Amplifier**

The 1-10 watt UHF power amplifier is designed to cover the range of 438-470 MHz and has three stages. The first stage, Q2510, operates in Class A. Its operating voltage is supplied from 9.6T. This stage provides 9 dB of gain and an output of 200 milliwatts.

The second stage, Q2520, has a nominal gain of 10 dB and power output of up to 2 watts. The output of this stage is adjusted by varying the controlled B+ which supplies DC operating voltage to its collector. This stage operates in Class C.

## RF Power Amplifiers

The third stage, Q2530, is the Class C RF final power amplifier. It provides 8.75 dB of gain and an output power of up to 15 watts. Collector voltage is supplied from UNSW B+ via a 0.2 ohm resistor, R2570. By measuring the voltage drop across this resistor, the power control circuit compensates for variations in Q2530's collector current.

The antenna switch consists of two pin diodes, CR2550 and CR2551. L2553 is parallel-resonant with the off capacitance of CR2550, increasing the diode's isolation when turned off. C2555 is a DC block. L2552 and C2551, combined with the "on" inductance of CR2551, form a series resonant circuit to lower the shunt impedance presented by CR2551 when it is turned on.

In the receive mode, both diodes are off. Signals applied at the antenna jack J1 are routed, via the harmonic filter, through network L2551, C2552 and C2553 to the receiver input. In the transmit mode, 9.6T is present and both diodes are forward-biased into conduction. The transmitter RF from Q2530 is routed through CR2550, and via the harmonic filter to the antenna jack. CR2551 conducts, shunting RF power and preventing it from reaching the receiver. L2551 is selected to appear as a 1/4 wave at UHF, so that the low impedance of CR2551 appears as a high impedance at the junction of CR2550 and the harmonic filter input.

The harmonic filter is a seven pole 0.1 dB ripple Chebyshev low pass filter with a 3 dB frequency of approximately 700 MHz and less than 1 dB insertion loss.

### 10-25 Watt UHF Power Amplifier

The 10-25 watt UHF power amplifier is designed to cover the range of 438-470 MHz and has four stages. The first stage, Q2610, operates in Class A with base bias from 9.6T. It provides 11.8 dB of gain and an output of 300 milliwatts.

The second stage, Q2620, has a nominal gain of 8.2 dB and power output of up to 2 watts. The output of this stage is adjusted by the controlled B+ voltage which supplies its collector.

The third stage, Q2630, operates in Class C with 8.1 dB gain and a power output of up to 13 watts. Collector voltage is directly from UNSW B+.

The fourth stage, Q2640, is the final RF power amplifier, which operates Class C directly from UNSW B+. It provides up to 30 watts output. Collector current is monitored by the power control circuit by measuring the voltage drop across a .05 ohm resistor, R2670, in series with the collector DC supply lead.

The antenna switch consists of two pin diodes, CR2650 and CR2651. L2652 and C2651-2, combined with the "on" inductance of CR2651, form a series resonant circuit to lower the shunt impedance presented by

CR2651 when it is turned on. In the receive mode, both diodes are off. Signals applied at the antenna jack J1 are routed, via the harmonic filter, through network L2651, C2652 and C2653 to the receiver input. In the transmit mode, 9.6T is present and both diodes are forward-biased into conduction. The transmitter RF from Q2640 is routed through CR2650, and via the harmonic filter to the antenna jack. CR2651 conducts, shunting RF power and preventing it from reaching the receiver. L2651 is selected to appear as a 1/4 wave at UHF, so that the low impedance of CR2651 appears as a high impedance at the junction of CR2650 and the harmonic filter input.

The harmonic filter is a seven pole 0.1 dB ripple Chebyshev low pass filter with a 3 dB frequency of approximately 500 MHz and less than 1 dB insertion loss in the passband.

### 25-35/40 Watt UHF Power Amplifiers

There are four high-power UHF amplifiers, which provide 25-40 watts output in the 403-433, 438-470 or 465-490 MHz bands, or 25-35 watts output in the 490-520 MHz band. All have four stages and are similar in circuitry and layout.

The first stage, Q2710, operates in Class A with operating voltage obtained from 9.6T. The second stage, Q2720, is a gain-controlled Class C stage, the output power of which is adjusted by varying the controlled B+ collector DC supply. The third stage, Q2730, operates in Class C with collector voltage obtained directly from UNSW B+. The fourth stage, Q2740, is the final RF power amplifier, which operates Class C directly from UNSW B+. Specific operating parameters are:

Range	403-433	438-470	465-495	490-520
Stage 1 Gain: P <sub>OUT</sub> :	11.8 dB 300 mW	11.8 dB 300 mW	10 dB 200 mW	10 dB 200 mW
Stage 2 Gain: P <sub>OUT</sub> :	8.2 dB 2 W	8.2 dB 2 W	9.5 dB 1.8 W	9.5 dB 1.8 W
Stage 3 Gain: P <sub>OUT</sub> :	8.1 dB 13 W	8.1 dB 12.9 W	8.5 dB 13 W	8.5 dB 13 W
Stage 4 Gain: P <sub>OUT</sub> :	5.9 dB 50 W	6.1 dB 52.8 W	6.3 dB 55 W	5.7 dB 48 W

Collector current of the final stage is monitored by the power control circuit by measuring the voltage drop across a .01 ohm resistor, R2770, in series with the collector DC supply lead.

The antenna switch consists of two pin diodes, CR2750 and CR2751. L2753, when used, is parallel-resonant with the off capacitance of CR2750, increasing the diode's isolation when turned off. C2755 is a DC block, present if L2753 is used. L2752 and C2750-1, combined

with the internal “on” inductance of CR2751, form a series resonant circuit to lower the shunt impedance presented by CR2751 when it is conducting.

In the receive mode, both diodes are off. Signals applied at the antenna jack J1 are routed, via the harmonic filter, through network L2751, C2752 and C2753 to the receiver input. In the transmit mode, 9.6T is present and both diodes are forward-biased into conduction. The transmitter RF from Q2740 is routed through CR2750, and via the harmonic filter to the antenna jack. CR2751 conducts, shunting RF power and preventing it from reaching the receiver. L2751 is selected to appear as a 1/4 wave at the appropriate operating frequency range so that the low impedance of CR2751 appears as a high impedance at the junction of CR2750 and the harmonic filter input.

The harmonic filters are seven pole low pass designs having either a 0.1 dB ripple Chebychev response (403-433 MHz and 438-470 MHz bands) or a Butterworth response (465-495 and 490-520 MHz). They are characterized as follows:

Range	403-433	438-470	465-495	490-520
f(-3 dB):	520 MHz	510 MHz	620 MHz	650 MHz
Loss:	0.8 dB	0.8 dB	0.8 dB	0.8 dB

## Front Panel Boards

The front panel housing itself contains two circuit boards, the Display Board and the Volume/Mic Board. There are two different types of Display Boards, depending on model. In 2-frequency models, discrete LED's provide channel indication. In 8 or 16 frequency models, seven-segment LED displays are used.

A third board, the Front Panel Filter Board, is located on the front of the radio chassis.

### Display Board

The 2-Frequency Display Board consists of four discrete LED's. Two are dual color type. They indicate channel 1 or 2, and turn from green to red when the radio is in the transmit mode.

The logic board provides the following control signals:

TX/BUSY (P9-1) is floating in RX mode, and active low in TX mode; FPE (P9-4) supplies 5V via 10k for F2, and 0V via 10k for F1. This allows four display conditions, as follows:

- F1 RECEIVE: P9-4 is low, therefore Q1003 is off (DS1002 cannot light) and Q1001 is on (DS1001 cathodes are grounded). In receive, P9-1 floats, causing DS1001 GRN to light via R1003, and Q1002 is saturated, shorting out DS1001 RED so it doesn't light.

- F1 TRANSMIT: P9-4 is low, therefore Q1003 is off (DS1002 cannot light) and Q1001 is on (DS1001 cathodes are grounded). In transmit, P9-1 is active low, turning off Q1002 and allowing DS1001 RED to light via R1004. Also, since P9-1 is low, DS1001 GRN is shorted out and cannot light.
- F2 RECEIVE: P9-4 is high via 10k, therefore Q1003 is saturated, grounding the cathodes of DS1002 and turning off Q1001. Since Q1001 is off, DS1001 cannot light. In receive, P9-1 floats, causing DS1002 GRN to light via R1003, and Q1002 is saturated, shorting out DS1002 RED so it doesn't light.
- F2 TRANSMIT: P9-4 is high via 10k, therefore Q1003 is saturated, grounding the cathodes of DS1002 and turning off Q1001. Since Q1001 is off, DS1001 cannot light. In transmit, P9-1 is active low, turning off Q1002 and allowing DS1002 RED to light via R1004. Also, since P9-1 is low, DS1002 GRN is shorted out and cannot light.

DS1004 (Monitor) lights when Q1004 is saturated by 5V via 10k applied to FPD (P9-3). DS1004 (Busy) lights when Q1005 is saturated by 5V via 10k applied to FPC (P9-6).

SW1001 (Mode) and SW1002 (Monitor) are normally-open pushbuttons which provide a low to FPA (P9-7) and FPB (P9-5) respectively.

### Display Board (8/16 Freq Models)

The 8/16 Frequency Display Board consists of three colored indicator LED's (DS1101-3), three green LED's which illuminate the keypad buttons (DS1105-7), a dual 7-segment LED display (DS1104), a display driver IC (U1101) and five momentary pushbuttons (SW1101-5).

After power up, the microcomputer loads U1101 with information using the SERIAL DATA (P9-10), SERIAL CLOCK (P9-11), and DISPLAY ENABLE (P9-2) lines. This data tells U1101 which segments and indicator LED's to illuminate. U1101 is a shift register latch. Its outputs are active low when a particular LED is to be illuminated, or open circuit when an LED is to remain off. The anodes of all LED indicators or segments are connected to the +5V DC source. The three keypad illumination LED's are lit at all times when +5V is present.

SW1101 through SW1105 are normally-open momentary pushbuttons. When pressed, the conductive ink on the back side of the rubber pushbutton comes in contact with the exposed circuit pattern on the display circuit board, providing a low resistance (less than 100 ohms) path to ground.

### ***Vol/Mic Board***

The VOL/MIC circuit board provides mounting and electrical connection to the microphone jack J11 and the on-off/volume control R9002. Connections are made to the logic board via P8. This cable/connector assembly also contains the two wires which route receiver audio to the internal 22 ohm speaker mounted in the front panel.

A 10 ohm resistor, R9001, is located between the CCW side of the volume control element and ground. At minimum volume setting, this maintains the attenuation at no greater than 46 dB, to avoid missing a message if the volume control is inadvertently turned to minimum.

### ***Front Panel Filter Board***

The front panel filter board is mounted to the front of the radio chassis. The pins of logic board connectors J8 and J9 pass through this board and are soldered to it. This board allows capacitive bypassing of all signal leads leaving the front of the radio chassis. This, combined with the shielding covers over the RF board, logic board and RF power amplifier, reduces the levels of cabinet radiation to extremely low levels.

In addition, the front panel filter board also provides protection against electrostatic discharge into front panel controls or indicators. Zener diodes are installed on any lines which are susceptible to damage from excessive static voltage transients, limiting voltage excursions to +27V or -0.7V DC.

# Section 3

## Jumper-Selectable Options

### Overview

Push-on jumpers, located on the logic board, allow the operation of the radio to be customized to specific applications, as explained below. This section contains information about the possible positions for each jumper, and the corresponding options.

### Jumper Positions

The standard position of each jumper, as shipped from the factory, is indicated in **bold**.

JU551	POSITION (A)	The receiver audio applied to the accessories connector J3 <b>pin 11 is flat (not de-emphasized) and unmuted.</b>
	<b>POSITION (B)</b>	The receiver audio applied to the accessories connector J3 pin 11 is de-emphasized and muted. Muting is controlled by the RX MUTE output from the microcomputer, as determined by carrier or tone squelch status.
JU601	<b>POSITION (A)</b>	The high-speed receive data path to the microcomputer is filtered to remove audio information below 300 Hz. This is used when decoding signaling data or tones which do not contain low frequency information.
	POSITION (B)	The high-speed receive data path to the microcomputer is essentially flat over the frequency range of less than 1 Hz to 3 kHz. This is used when decoding signaling data which includes very low frequency components.
JU651	<b>POSITION (A)</b>	Selects low microphone audio sensitivity, which is 80 mV rms for <b>60% of full system deviation.</b>
	POSITION (B)	Selects high microphone audio sensitivity, which is 40 mV rms for 60% of full system deviation. This position is not recommended in applications where high ambient noise is present.
**JU701	<b>POSITION (A)</b>	J3-5 functions as a Flat TX Audio Input which is routed through the limiter. Response is 0.6-3000 Hz. Sensitivity is 180 mV rms for 60% of full system deviation.
	POSITION (B)	J3-5 functions as an External PL Input, bypassing the limiter. Response is 0.7-300 Hz.
**JU808	<b>POSITION (A)</b>	Pin 12 of accessories connector J3 functions as a programmable I/O (input or output) as determined by the RSS.
	POSITION (B)	Pin 12 of accessories connector J3 functions as the SCI+ programming line. It is connected directly to the SCI+ line on microphone connector J11.
*JU809	<b>POSITION (A)</b>	Allows the use of a remote desk set which is connected to accessories connector J3. Pin 14 functions as the HOOK line. When pulled low, the radio is forced into the monitor (off-hook) position. Note that this is the opposite polarity of the HOOK function on the microphone connector J11.
	POSITION (B)	Allows the use of an HLN3145 Public Address system. Pin 14 of accessories connector J3 functions as the PA ENABLE line. In the public address mode this line is pulled low, inhibiting transmit PTT operation, but leaving all other radio functions unchanged.  <b>Note:</b> When a R*T*C*K Repeater adapter is used, the push-on jumper JU809 must be removed entirely.

\*Present on 2-layer masked logic board (HLN8074) only.

\*\*Present on 4-layer expanded logic board (HLN8070) only



Jumper Positions

# Section 4

## Non-Field Servicable Components

---

---

---

---

---

---

---

---

---

---

### Overview

This section explains the operation of the reference oscillator and lists all non-field serviceable components in the GM300 mobile radios.

### Operation of the Reference Oscillator

The frequency stability of the reference oscillator in the GM300 mobile radios is maintained by electronically measuring the temperature of the oscillator's crystal, computing the control voltage needed to accurately compensate for the temperature-dependent frequency shift of the crystal, and applying this voltage to the tuning varactors in the oscillator circuit.

For accurate temperature compensation, the characteristics of the oscillator and crystal are measured at the factory, and this information is programmed into the microcomputer on the logic board.

### Non-Field Servicable Components

Field-replacement of the microcomputer on the logic board, or of any components in the reference oscillator or temperature-sensing circuit on the RF board, will impair the accuracy of this compensation technique. For this reason, **these components cannot be replaced in the field.** If any of these components require service, the entire RF or logic board must be replaced. The Radio Service Software calibration procedure for board replacement must be performed after the new board has been installed. This step re-enters the temperature characteristic of the new oscillator into the old microcomputer, or vice-versa.

The following components are not field-serviceable:

Ref. No.	Part No.	Description	Location
C151	21-13740B73	chip capacitor, 1000 pF	RF Board
C152	21-13740B47	chip capacitor, 82 pF	RF Board
C153	21-13740B25	chip capacitor, 10 pF	RF Board
C154	21-13741B45	chip capacitor, .01 uF	RF Board
C155, 156	21-13740B55	chip capacitor, 180 pF	RF Board
C157	21-13741B45	chip capacitor, .01 uF	RF Board
C158	08-11051A15	poly capacitor, 0.22 uF, 63 V	RF Board
C159	21-13740B35	chip capacitor, 27 pF	RF Board
C160	21-13740B29	chip capacitor, 15 pF	RF Board
C161	21-13740B73	chip capacitor, 1000 pF	RF Board
C163	08-11051A17	poly capacitor, 0.47 uF, 63 V	RF Board
C164	21-13741B69	chip capacitor, 0.1 uF	RF Board
C165	21-13740B73	chip capacitor, 1000 pF	RF Board
C166 thru 168	21-13740B49	chip capacitor, 100 pF	RF Board
C176	21-13740B73	chip capacitor, 1000 pF	RF Board
C177	21-13741B69	chip capacitor, 0.1 uF	RF Board
CR151, 152	48-80006E10	silicon varactor SOT	RF Board
CR153	48-84336R03	dual silicon SOT MMBD7000	RF Board
L151	24-80299D01	coil, tunable 17-3/4 turns	RF Board
L152	24-11087A35	chip coil, 5.6 uH, 10%	RF Board
Q151	48-11043C19	NPN; type M43C19/M9658	RF Board
Q152	48-11043C06	PNP; type M43C06/M9643	RF Board
R151	06-11077B15	chip resistor, 47k	RF Board
R152	06-11077B11	chip resistor, 33k	RF Board
R153	06-11077B15	chip resistor, 47k	RF Board
R154	06-11077A34	chip resistor, 22	RF Board
R155	06-11077A98	chip resistor, 10k	RF Board
R156	06-11077B03	chip resistor, 15k	RF Board
R157	06-11077A78	chip resistor, 1.5k	RF Board
R158	06-11077A74	chip resistor, 1k	RF Board
R161	06-11077A98	chip resistor, 10k	RF Board

## Non-Field Servicable Components

<b>Ref. No.</b>	<b>Part No.</b>	<b>Description</b>	<b>Location</b>
R176	06-11077G26	chip resistor, 22.6k, 1%	RF Board
R177	06-11077G18	chip resistor, 18.7k, 1%	RF Board
R178, 179	06-11077F91	chip resistor, 10.0k, 1%	RF Board
R180	06-11077G52	chip resistor, 42.2k, 1%	RF Board
R181	06-11077F91	chip resistor, 10.0k, 1%	RF Board
R182	06-11077C28	chip resistor, 23.7k, 1%	RF Board
U176	51-80932W01	dual op-amp	RF Board
VR176	48-82256C11	Zener diode, 10 V, 5%	RF Board
Y151	48-80174D05	crystal, 14.4 MHz	RF Board
U401	51-80649B01	microcomputer	2-Layer Masked Logic Board
U401	51-80960T01	microcomputer	4-Layer Expanded Logic Board

# Parts List

HLE8230A RF Board, 403-433 MHz, 12.5 kHz (N)

HLE8229A RF Board, 403-433 MHz, 25 kHz (W)

PL-921021-O

REFERENCE SYMBOL	MOTOROLA PART NO.	DESCRIPTION
		<b>capacitor, chip: +/-5%; 5 V:</b> unless otherwise stated
C1, 2	21-13740G27	8.2 ±0.1 pF
C3	21-13740G17	3.9 ±0.1 pF
C4	21-13740G30	11 pF 2%
C5	21-13740G21	5.6 ±0.1 pF
C6	21-13740G19	4.7 ±0.1 pF
C7	21-13740G27	8.2 ±0.1 pF
C8	21-13740G17	3.9 ±0.1 pF
C9	21-13740G21	5.6 ±0.1 pF
C10	21-13740G27	8.2 ±0.1 pF
C11	21-13740G32	13 pF 2%
C12	21-13740B45	68 pF
C13	21-13740G27	8.2 ±0.1 pF
C14		not used
C15	21-13740G13	2.7 ±0.1 pF
C16	21-13740G20	5.1 ±0.1 pF
C17	21-13740G37	22 pF 2%
C18	21-13740G19	4.7 ±0.1 pF
C19	21-13740G16	3.6 ±0.1 pF
C20	21-13740G36	20 pF 2%
C21	21-13740G18	4.3 ±0.1 pF
C22	21-13740G17	3.9 ±0.1 pF
C23	21-13740G35	18 pF 2%
C24	21-13740G20	5.1 ±0.1 pF
C25	21-13740G29	10 pF 2%
C26	21-13740G31	12 pF 2%
C27	21-11032B15	0.22 uF +80/-20%
C28	21-13740B45	68 pF
C29		not used
C30	21-13740B35	27 pF
C33	21-13741B45	.01 uF
C51	21-13740B55	180 pF
C52	21-13740B27	12 pF
C53	21-13740B47	82 pF
C54	21-13740B61	330 pF
C55, 56	21-13741B45	.01 uF
C57(N)	21-13740B29	15 pF
C57(W)	21-13740B31	18 pF
C58(N)	21-13740B25	10 pF
C58(W)	21-13740B27	12 pF
C59(N)	21-13740B29	15 pF
C59(W)	21-13740B31	18 pF
C60, 61	21-13741B45	.01 uF
C65	21-11032B15	0.22 uF +80/-20%
C66	21-13741B45	.01 uF
C67	23-13749C39	tantalum 10 uF 10% 20V
C68	21-13740B29	15 pF
C69	21-13740B39	39 pF
C70	21-13740B29	15 pF
C71, 72	21-11032B15	0.22 uF +80/-20%
C73	23-13749C39	tantalum 10 uF 10% 20V
C74	23-11048B13	lytic 10 uF 20% 16V
C75	21-13741B69	0.1 uF
C76	23-11048B05	lytic 1 uF 20% 50V
C77, 78	21-11032B15	0.22 uF +80/-20%
C79	21-13741B29	.0022 uF
C80	21-11032B15	0.22 uF +80/-20%
C81	21-13740B55	180 pF
C82, 83	21-11032B15	0.22 uF +80/-20%
C84	21-13740B09	2.2 ±.25 pF
C85	21-13740B25	10 pF
C86, 87	21-11032B15	0.22 uF +80/-20%
C90	21-13741B45	.01 uF
C91	21-13740B49	100 pF
C101	23-11048B13	lytic 10 uF 20% 16V
C102	08-11051A13	poly 0.1 uF 63V
C103	21-11032B15	0.22 uF +80/-20%
C104	21-13741B45	.01 uF
C105	23-11048B13	lytic 10 uF 20% 16V
C106	21-13740B29	15 pF
C107, 108	21-13741B69	0.1 uF
C109	08-11051A13	poly 0.1 uF 63V
C110	08-11051A19	poly 1 uF 63V
C111	08-11051A09	poly .022 uF 63V
C112	08-11051A01	poly .001 uF 63V
C113	21-13741B45	.01 uF
C114	21-13740B45	68 pF
C115	21-13741B45	.01 uF
C116	21-13740B49	100 pF
C117, 118		not used
C119, 120	21-13740B45	68 pF
C121	21-13740B19	5.6 ±.25 pF

HLE8230A RF Board, 403-433 MHz, 12.5 kHz (N)

HLE8229A RF Board, 403-433 MHz, 25 kHz (W)

PL-921021-O

REFERENCE SYMBOL	MOTOROLA PART NO.	DESCRIPTION
C122	21-13740B49	100 pF
C123	21-13740B45	68 pF
C124	21-13740B25	10 pF
C125	21-13740B73	1000 pF
C126		not used
C127 thru 132	21-11032B15	0.22 uF +80/-20%
C133	21-13740B49	100 pF
C151	21-13740B73	1000 pF
C152	21-13740B47	82 pF
C153	21-13740B25	10 pF
C154	21-13741B45	.01 uF
C155, 156	21-13740B55	180 pF
C157		not used
C158	08-11051A15	poly 0.22 uF 63V
C159	21-13740B35	27 pF
C160	21-13740B29	15 pF
C161	21-13740B73	1000 pF
C162	23-11048B13	lytic 10 uF 20% 16V
C163	08-11051A17	poly 0.47 uF 63V
C164	21-11032B15	0.22 uF +80/-20%
C165	21-13741B33	.0033 uF
C176	21-13740B73	1000 pF
C201	23-11048B13	lytic 10 uF 20% 16V
C205	21-13740B49	100 pF
C206	21-13740B16	4.3 ±0.25 pF
C207	21-13740B19	5.6 ±0.25 pF
C208	21-13740B14	3.6 ±0.25 pF
C209	21-13740B14	3.6 ±0.25 pF
C210	21-13740B49	100 pF
C212	21-13740B49	100 pF
C213	21-13740B01	1 ±0.25 pF
C214	21-13740B13	3.3 ±0.25 pF
C215	21-13740B49	100 pF
C216	21-13740B13	3.3 ±0.25 pF
C218	21-13740B49	100 pF
C220	21-13740B25	10 pF
C221	21-13740B05	1.5 ±0.25 pF
C222	21-13740B49	100 pF
C224, 225	21-13740B49	100 pF
C228	21-13741B29	.0022 uF
C230, 231	21-13740B05	1.5 ±0.25 pF
C233	21-13740B18	5.1 ±0.25 pF
C234	21-13740B23	8.2 ±0.25 pF
C235	21-13740B22	7.5 ±0.25 pF
C236	21-13740B22	7.5 ±0.25 pF
C237	21-13740B49	100 pF
C239	21-13740B49	100 pF
C240	21-13740B05	1.5 ±0.25 pF
C242	21-13740B49	100 pF
C243	21-13740B13	3.3 ±0.25 pF
C244	21-11032B15	0.22 uF +80/-20%
C245	21-13740B45	68 pF
C247	21-13740B23	8.2 ±0.25 pF
C248	21-13740B01	1 ±0.25 pF
C249	21-13740B49	100 pF
C251	21-13740B45	68 pF
C252	21-13740B49	100 pF
C253	21-13740B45	68 pF
C255		not used
C256	21-13741B45	.01 uF
C257		not used
C258	08-11051A07	poly .01 uF 63V
C259	21-13740B23	8.2 ±0.25 pF
C260		not used
C261	21-13741B45	.01 uF
C262		not used
C263	21-13740B19	5.6 ±.25 pF
C264		not used
C265		not used
C266	21-13740B03	1.2 ±0.25 pF
C267	21-13740B01	1 ±0.25 pF
C268	21-13740B13	3.3 ±0.25 pF
C269	21-13740B09	2.2 ±0.25 pF
C270, 271		not used
C272	21-13740B45	68 pF
C273		not used
C274	21-13740B49	100 pF
C275, 276	21-13741B45	.01 uF
C277, 278	23-11048B19	lytic 47 uF 20% 16V
C279	21-13740B45	68 pF
C280	21-11032B15	0.22 uF +80/-20%
C301	21-13741B45	.01 uF
C302, thru 313	21-13740B45	68 pF

REFERENCE SYMBOL	MOTOROLA PART NO.	DESCRIPTION
C314	21-13740B49	100 pF
CR2	48-80154K03	dual Schottky SOT
CR3	48-80939T01	Schottky SOT
CR5	48-80142L01	silicon PIN SOT MMBV3401
CR51	48-05129M76	silicon SOT
CR52	48-05129M76	silicon SOT
CR101	48-05129M76	silicon SOT
CR102	48-05129M76	silicon SOT
CR151	48-80006E10	silicon varactor SOT
CR152	48-80006E10	silicon varactor SOT
CR153	48-84336R03	dual silicon SOT MMBD7000
CR203	48-84534N02	silicon varactor SOT
CR205	48-84534N02	silicon varactor SOT
CR206	48-80154K02	dual Schottky SOT
CR209	48-84534N02	silicon varactor SOT
CR211	48-84534N02	silicon varactor SOT
CR213	48-84534N02	silicon varactor SOT
CR214	48-80939T01	Schottky SOT
		<b>diode: (see note)</b>
		dual Schottky SOT
		Schottky SOT
		silicon PIN SOT MMBV3401
		silicon SOT
		silicon SOT
		silicon SOT
		silicon varactor SOT
		silicon varactor SOT
		dual silicon SOT MMBD7000
		silicon varactor SOT
		silicon varactor SOT
		dual Schottky SOT
		silicon varactor SOT
		silicon varactor SOT
		silicon varactor SOT
		Schottky SOT
		<b>filter:</b>
		455 kHz 6F
		455 kHz 6D
		455 kHz 4F
		455 kHz 4D
		<b>connector, receptacle:</b>
		coaxial (RX)
		14-pin, RF board
		<b>jumper:</b>
		jumper
		jumper
		jumper
		not used
		<b>coil, rf:</b>
		4 turns airwound
		chip 12 nH 5%
		chip 18 nH 5%
		chip 0.12 uH 5%
		7-1/2 turns YEL
		chip 1 uH 5%
		chip 0.18 uH 5%
		chip 4.7 uH 5%
		tunable 0.7 uH E715
		tunable 0.7 uH E713
		tunable 0.7 uH E714
		chip 4.7 uH 5%
		tunable 0.7 uH E716
		chip 1.2 uH 5%
		tunable 455 kHz with cap
		chip 0.18 uH 5%
		chip 33 nH 5%
		tunable 17-3/4 turns
		chip 5.6 uH 10%
		tunable 2-1/2 turns RED
		chip 0.15 uH 5%
		5 turns GRN
		chip 0.15 uH 5%
		chip 0.15 uH 5%
		chip 0.22 uH 5%
		2-1/2 turns GRN
		4-1/2 turns BRN
		chip 0.22 uH 5%
		tunable 1-1/2 turns BRN
		chip 0.15 uH 5%
		4-1/2 turns BRN
		chip 0.15 uH 5%
		chip 0.15 uH 5%
		chip 0.22 uH 5%
		2-1/2 turns GRN
		4-1/2 turns BRN
		chip 0.18 uH 5%
		not used
		<b>transistor: (see note)</b>
		NPN; type M50X01
		PNP; type MMBT3906
		NPN; type MMBT3904
		field effect; type MMBFU310
		NPN; type MMBT3904

REFERENCE SYMBOL	MOTOROLA PART NO.	DESCRIPTION
Q101	48-05128M67	PNP; type MMBT3906
Q102, 103	48-80182D20	NPN; type M82D20/M9987
Q104	48-05128M67	PNP; type MMBT3906
Q105, 106	48-80214G02	NPN; type MMBT3904
Q107	48-11043C19	NPN; type M43C19/M9658
Q151	48-11043C19	NPN; type M43C19/M9658
Q152	48-11043C06	PNP; type M43C06/M9643
Q203	48-05128M66	field effect; type MMBFU310
Q204, 205	48-80950X01	NPN; type M50X01
Q206	48-05128M66	field effect; type MMBFU310
Q207, 208	48-80950X01	NPN; type M50X01
Q276	48-80214G02	NPN; type MMBT3904
Q277 thru 279	48-05128M67	PNP; type MMBT3906
		<b>resistor, fixed: +/-5%; 1/10 W:</b>
		unless otherwise stated
R1	06-11077A84	2.7k
R2	06-11077A54	150
R3	06-11077A60	270
R4	06-11077B07	22k
R5	06-11077A95	7.5k
R6	06-11077A90	4.7k
R7, 8	06-11077A98	10k
R9	06-11077A90	4.7k
R10	06-11077B07	22k
R11	06-11077B15	47k
R12	06-11077A45	62
R13	06-11077A65	430
R51	06-11077A44	56
R52	06-11077A54	150
R53	06-11077A88	3.9k
R54	06-11077A54	150
R56	06-11077B45	820k
R57	06-11077A72	820
R58	06-11077B23	100k
R59	06-11077B27	150k
R60	18-05500L08	variable 22k
R61(N)	06-11077B07	22k
R61(W)	06-11077B19	68k
R62(N)	06-11077A26	10
R62(W)	06-11077B09	27k
R63	06-11077B21	82k
R102	06-11077A62	330
R103, 104	06-11077A98	10k
R105	06-11077B11	33k
R106	06-11077A73	910
R107	06-11077A78	1.5k
R108, 109	06-11077A26	10
R110	06-11077B03	15k
R111	06-11077A54	150
R112	06-11077A72	820
R113	06-11077A58	220
R114	06-11077A54	150
R115	06-11077A70	680
R116	06-11077A92	5.6k
R118	06-11077A70	680
R119, 120	06-11077A88	3.9k
R121	06-11077A84	2.7k
R122	06-11077A88	3.9k
R123	06-11077A74	1k
R124	06-11077A78	1.5k
R125	06-11077A44	56
R126	06-11077A50	100
R127	06-11077A84	2.7k
R128	06-11077A72	820
R151	06-11077B15	47k
R152	06-11077B11	33k
R153	06-11077B15	47k
R154	06-11077A34	22
R155	06-11077A98	10k
R156	06-11077B03	15k
R157	06-11077A78	1.5k
R158, 159	06-11077A74	1k
R161	06-11077A98	10k
R162		not used
R163(N)	06-11077B23	100k
R163(W)	06-11077B17	56k
R164	18-05500L08	variable 22k
R165(N)	06-11077A98	10k
R165(W)	06-11077B03	15k
R176	06-11077G26	22.6k 1%
R177	06-11077G18	18.7k 1%
R178, 179	06-11077F91	10.0k 1%

REFERENCE SYMBOL	MOTOROLA PART NO.	DESCRIPTION
R180	06-11077G52	42.2k 1%
R181	06-11077F91	10.0k 1%
R182	06-11077G28	23.7k 1%
R207	06-11077A44	56
R208, 209	06-11077A38	33
R210	06-11077A98	10k
R212	06-11077A84	2.7k
R213	06-11077A72	820
R214	06-11077A50	100
R215	06-11077A84	2.7k
R216	06-11077A72	820
R217	06-11077A50	100
R218	06-11077A53	130
R219	06-11077A41	43
R220	06-11077A53	130
R222	06-11077A88	3.9k
R223	06-11077A94	6.8k
R224	06-11077B23	100k
R225	06-11077A88	3.9k
R226	06-11077A44	56
R227, 228	06-11077A38	33
R229	06-11077A98	10k
R231	06-11077A84	2.7k
R232	06-11077A72	820
R233	06-11077A50	100
R234	06-11077A84	2.7k
R235	06-11077A72	820
R236	06-11077A50	100
R237	06-11077A61	300
R238	06-11077A32	18
R239	06-11077A61	300
R240		not used
R243	06-11077B23	100k
R244, 245	06-11077A74	1k
R246	06-11077B09	27k
R276	06-11077A98	10k
R277	06-11077A60	270
R278	06-11077A26	10
R279	06-11077A90	4.7k
R280	06-11077A98	10k
R281	06-11077A90	4.7k
R301(N)	06-11077B03	15k
R301(W)	06-11077A82	2.2k
R302	18-05500L08	variable 22k
R303	06-11077A94	6.8k
<b>transformer:</b>		
T1, 2	25-80163M02	balun
<b>integrated circuit: (see note)</b>		
U1	48-80174R01	quad Schottky ring SOIC
U51	51-05479G05	receiver system
U101	51-84704M75	synthesizer
U102	51-83977M45	prescaler
U176	51-80932W01	dual op-amp
<b>voltage regulator: (see note)</b>		
VR176	48-82256C11	Zener diode 10V 5%
<b>crystal: (see note)</b>		
Y51(N)	91-80022M03	filter 45.1 MHz 12.5 kHz
Y51(W)	91-80022M02	filter 45.1 MHz 25 kHz
Y52	48-80008K02	44.645 MHz
Y151	48-80174D05	14.4 MHz

**non-referenced items**

26-80097M01	shield coil can (for L151)
26-80098M01	shield coil can (17 used)
26-80228L01	shield can (for J4)
26-80229L03	shield VCO frame
26-80256L02	shield image
42-80957X01	ground clip
75-05295B02	insulator (for Y151)
75-05295B07	insulator (3 used, for Y51A/B, Y52)

**note:** For optimum performance, diodes, transistors, and integrated circuits must be ordered by Motorola part numbers.

REFERENCE SYMBOL	MOTOROLA PART NO.	DESCRIPTION
R180	06-11077G52	42.2k 1%
R181	06-11077F91	10.0k 1%
R182	06-11077G28	23.7k 1%
R207	06-11077A44	56
R208, 209	06-11077A38	33
R210	06-11077A98	10k
R212	06-11077A84	2.7k
R213	06-11077A72	820
R214	06-11077A50	100
R215	06-11077A84	2.7k
R216	06-11077A72	820
R217	06-11077A50	100
R218	06-11077A53	130
R219	06-11077A41	43
R220	06-11077A53	130
R222	06-11077A88	3.9k
R223	06-11077A94	6.8k
R224	06-11077B23	100k
R225	06-11077A88	3.9k
R226	06-11077A44	56
R227, 228	06-11077A38	33
R229	06-11077A98	10k
R231	06-11077A84	2.7k
R232	06-11077A72	820
R233	06-11077A50	100
R234	06-11077A84	2.7k
R235	06-11077A72	820
R236	06-11077A50	100
R237	06-11077A61	300
R238	06-11077A32	18
R239	06-11077A61	300
R240		not used
R243	06-11077B23	100k
R244, 245	06-11077A74	1k
R246	06-11077B09	27k
R276	06-11077A98	10k
R277	06-11077A60	270
R278	06-11077A26	10
R279	06-11077A90	4.7k
R280	06-11077A98	10k
R281	06-11077A90	4.7k
R301(N)	06-11077B03	15k
R301(W)	06-11077A82	2.2k
R302	18-05500L08	variable 22k
R303	06-11077A94	6.8k
<b>transformer:</b>		
T1, 2	25-80163M02	balun
<b>integrated circuit: (see note)</b>		
U1	48-80174R01	quad Schottky ring SOIC
U51	51-05479G05	receiver system
U101	51-84704M75	synthesizer
U102	51-83977M45	prescaler
U176	51-80932W01	dual op-amp
<b>voltage regulator: (see note)</b>		
VR176	48-82256C11	Zener diode 10V 5%
<b>crystal: (see note)</b>		
Y51(N)	91-80022M03	filter 45.1 MHz 12.5 kHz
Y51(W)	91-80022M02	filter 45.1 MHz 25 kHz
Y52	48-80008K02	44.645 MHz
Y151	48-80174D05	14.4 MHz

**non-referenced items**

26-80097M01	shield coil can (for L151)
26-80098M01	shield coil can (17 used)
26-80228L01	shield can (for J4)
26-80229L03	shield VCO frame
26-80256L02	shield image
42-80957X01	ground clip
75-05295B02	insulator (for Y151)
75-05295B07	insulator (3 used, for Y51A/B, Y52)

**note:** For optimum performance, diodes, transistors, and integrated circuits must be ordered by Motorola part numbers.

# Parts List

HLE8275A PA Board, 403-433 MHz, 25/40 Watt

PL-921030-O

REFERENCE SYMBOL	MOTOROLA PART NO.	DESCRIPTION
		<b>capacitor, chip: +/-5%; 50 V:</b> unless otherwise stated
C2710	21-13740B49	100 pF
C2711	21-13740B27	12 pF
C2712	21-13740B34	24 pF
C2713, 2714	21-13740B73	1000 pF
C2715	21-13740B21	6.8 ±0.25 pF
C2716	21-13741B69	0.1 uF
C2717	21-13740B36	30 pF
C2718	21-13740B49	100 pF
C2719		not used
C2720, 2721	21-13740B32	20 pF
C2722 thru 2725		not used
C2726	21-13740B49	100 pF
C2727	21-13740B73	1000 pF
C2728	21-11032B15	0.22 uF +80/-20%
C2729	21-13740B36	30 pF
C2730	21-13740B32	20 pF
C2731, 2732	21-11078B25	27 pF 100V
C2733	21-11032B15	0.22 uF +80/-20%
C2735		not used
C2736	21-13740B49	100 pF
C2737	21-13740B73	1000 pF
C2738	21-13741B69	0.1 uF
C2739	23-11048A17	lytic 33 uF 20% 25V
C2740	21-11078B35	51 pF 100V
C2745	21-80060M20	11 pF 500V
C2746	21-80060M13	7 ±0.25 pF 500V
C2747	21-80060M31	33 pF 500V
C2748	21-11032B15	0.22 uF +80/-20%
C2749	21-13740B49	100 pF
C2750	21-80060M26	20 pF 500V
C2751	21-13740B17	4.7 ±0.25 pF
C2752		not used
C2753	21-13740B27	12 pF
C2754, 2755	21-13740B49	100 pF
C2756	21-80060M20	11 pF 500V
C2757	21-80060M13	7 ±0.25 pF 500V
C2758		not used
C2760	21-80060M19	10 pF 500V
C2761	21-80060M15	8 ±0.25 pF 500V
C2762	21-80060M17	9 ±0.25 pF 500V
C2763	21-80060M11	6 ±0.25 pF 500V
C2764	21-80060M43	100 pF 100V
C2765	23-11048A17	lytic 33 uF 20% 25V
C2768		not used
C2770, 2771	21-13740B36	30 pF
C2772	21-13740B73	1000 pF
C2773	21-13741B69	0.1 uF
C2774	21-13740B36	30 pF
C2775	08-11051A17	poly 0.47 uF 63V
C2776	21-13740B36	30 pF
C2777	21-13740B73	1000 pF
C2778	21-13741B69	0.1 uF
C2779, 2780	21-13740B36	30 pF
C2781, 2782		not used
		<b>diode: (see note)</b> silicon PIN UM9401
CR2750, 2751	48-80010E01	
CR2770	48-80236E07	transient suppressor diode
		<b>ferrite beads:</b>
E2722	76-83960B01	ferrite bead 1/2 turn
E2770, 2771	76-83960B01	ferrite bead 1/2 turn
		<b>coil, rf:</b>
L2710	24-11030E02	1/2 turn RED
L2711	24-11030B04	1-1/2 turns YEL
L2712	24-11030E04	1/2 turn YEL
L2713	24-11030B01	1-1/2 turns BRN
L2714	24-80036A01	ferrite bead 1/2 turn
L2720	24-11030E01	1/2 turn BRN
L2721		not used
L2722	24-82723H44	.039 uH
L2730	24-11030A03	4 turns YEL
L2731	24-80036A01	ferrite bead 1/2 turn
L2732	24-11030A06	7 turns VIO
L2740	24-80036A01	ferrite bead 1/2 turn
L2741	24-11030A02	3 turns ORN
L2742	24-80908T11	1-1/2 turns RED
L2743	24-80908T01	1-1/2 turns RED
L2744		not used
L2750	24-82723H40	0.29 uH

HLE8275A PA Board, 403-433 MHz, 25/40 Watt

PL-921030-O

REFERENCE SYMBOL	MOTOROLA PART NO.	DESCRIPTION
L2751	24-11030B04	1-1/2 turns YEL
L2752	24-82723H40	0.29 uH
L2753	24-11030B11	6-1/2 turns ORN
L2760	24-80908T08	1-1/2 turns GRN
L2761	24-80908T10	1-1/2 turns GRN
L2762	24-80908T11	1-1/2 turns RED
L2763	24-11030B11	6-1/2 turns ORN
L2770	24-82723H46	0.2 uH
L2771	24-84346A02	0.23 uH
		<b>transistor: (see note)</b> NPN; type MRF559
Q2710	48-82233P39	
Q2720	48-80225C09	NPN; type MRF630
		<b>resistor, chip: +/-5%; 1/10 W:</b> unless otherwise stated
R2710	06-11077A60	270
R2711	06-11077A58	220
R2712	06-11077A52	120
R2713	06-11077A38	33
R2714	06-11077A38	33
R2715	06-11077A62	330
R2720	06-11077A26	10
R2740		not used
R2741	06-02369M10	metal film 5.6 0.6 watt
R2750, 2751	06-80194M15	39 1 watt
R2770	06-80147M02	metal plate .01 10% 2 watt
R2771	06-11077A28	12
R2772	06-05621T02	thermistor 50k
R2773	06-11077B11	33k
R2774	06-11077A76	1.2k
R2775	06-11077A26	10
		<b>non-referenced items</b>
	26-80158L01	heat sink (for Q2720)
	26-80275M01	heat sink (2 used for CR2750 and CR2751)
	29-80014A03	clip coax terminal (2 used)

**note:** For optimum performance, diodes, transistors, and integrated circuits must be ordered by Motorola part numbers.

# Parts List

HLN8277A PA Hardware Kit 403-433 MHz, 25/40 Watt

PL-921031-O

REFERENCE SYMBOL	MOTOROLA PART NO.	DESCRIPTION
<b>capacitor, chip:</b>		
C2741	21-11078B36	56 pF 100V
C2742	21-11078B37	62 pF 100V
C2743, 2744	21-11078B35	51 pF 100V
C2766, 2767		not used
<b>connector, receptacle:</b>		
J1	09-80131M01	mini UHF coax
J2	09-80255E01	power (includes feedthru)
<b>connector, plug:</b>		
P4	30-80138M08	coaxial cable 200 mm with plug
P5	30-80138M07	coaxial cable 150 mm with plug
<b>transistor: (see note)</b>		
Q2730	48-80225C19	NPN; type MRF654
Q2740	48-80225C24	NPN; type MRF650
<b>non-referenced items</b>		
	02-00007003	nut 8-32x5/16x1/8 (for J1)
	03-10943M10	screw M3x.5x8 (8 used)
	03-10943M11	screw M3x.5x10 (2 used for J2)
	04-00131974	washer (2 used for J2)
	04-05587G01	washer nylon (for J2)
	04-80943V01	lockwasher (for J1)
	26-80124L03	heat sink
	26-80223M07	PA shield
	26-80514C01	filter shield
	26-80551C01	antenna connector shield
	32-80014N03	gasket, accessory connector
	42-80281L01	ground clip (2 used for Q2740)

**note:** For optimum performance, diodes, transistors, and integrated circuits must be ordered by Motorola part numbers.



6880902Z32-A

Motorola  
Radius Division  
Hwy 34, West.  
Mt. Pleasant, IA 52641