

It applies a high current, 500 volts AC supply, to the proper point of the test circuit. It applies a regulated DC supply to the proper point in the circuit and selects its voltage from 10 to 250 volts in 10 volt steps. It applies an unregulated 350 volt DC supply to the proper point of the test circuit. It controls a decade fixed bias supply for bias voltages from 0 to 100 volts in 0.1 volt steps. It chooses a decade ac filament voltage from 0 to 119.9 volts in 0.1 volt steps. It chooses a decade dc filament voltage from 0 to 50 volts in 0.1 volt steps.

5.03 In this tester an effort has been made to test tubes under typical operating conditions and values recommended by tube handbooks. Instead of only Gm and emission tests being used, variations have been added to compliment them. Some examples of how the circuit selection system is used in testing various types of tubes are explained in the following paragraph.

5.04 The amplifying type tubes, which are those having control grids, are tested for Gm. Most of these are in the triode and pentode groups. Triodes are usually operated in either a fixed bias or self-bias circuit. Figure 6 illustrates that for triode fixed bias types the cathode is ground. The negative bias plus a small A.C. signal is added and applied to the grid. The plate of the tube is connected to one end of the Gm bridge circuit with the regulated DC or B+ connected to the other end. This circuit is set up by the card in the card switch and by pressing button 2 it is energized for the test.

Figure 6 shows that the triode self bias test resembles the fixed bias test except that the cathode is grounded through the biasing resistance which is shunted by a capacitor.

5.05 By referring to Figure 6 it is noted that pentodes are tested the same as triodes except for the addition of the screen and suppressor grids. In both cases the screen voltage is connected just before entering the Gm circuit. In fixed bias operation the suppressor grid is grounded directly while in the self bias case it is connected to the cathode.

5.06 Figure 7 shows a two-control grid type of heptode. In testing this tube the bias voltage is applied to each control grid but the signal is only applied to one at a time, which then makes a measurement of the respective grid to plate Gm. Two test cards are necessary for this type of tube.

5.07 Power pentodes used in pulse applications are given a normal Gm test but in addition receive a second test which is referred to as a "knee" test. In order to produce the necessary pulse power the plate current of these pentodes must sweep from near cut-off to full saturation at the knee of the plate current-plate voltage curves. The Gm test is important but the knee test is necessary for a complete check. The "knee" test circuit is shown in Figure 7.

5.08 Figure 7 shows two special tests that are made for triodes intended for computer application. In addition to the normal Gm test these tubes are normally tested for zero bias plate current (ON test) and for high bias plate current (OFF test). Since these tubes are intended for multivibrator application it has been found necessary to make these tests to assure proper operation.

5.09 DC Filament Tubes. Certain battery-operated tubes have directly heated or filamentary cathodes. These are tested the same as triodes or pentodes except in certain cases dc from the full wave silicone rectifier bridge is applied to the filament of the tube. Should shorts occur in this type of tube, the meter will deflect to the left under the leakage test. This can be disregarded as the shorts lamps will actually show the defect.

5.10 Diode type tubes are tested with several different circuits depending on the type of diode tested. In the full wave rectifier circuit shown in Figure 8, the 250 volt center tapped ac is applied directly across the plates of the tube. A load resistance with filter capacitor is connected to the cathode of the tube. The output current is measured by the meter being connected as a dc milliammeter. The load resistor is adjusted so that the average indicated current or emission will be for the handbook condition.

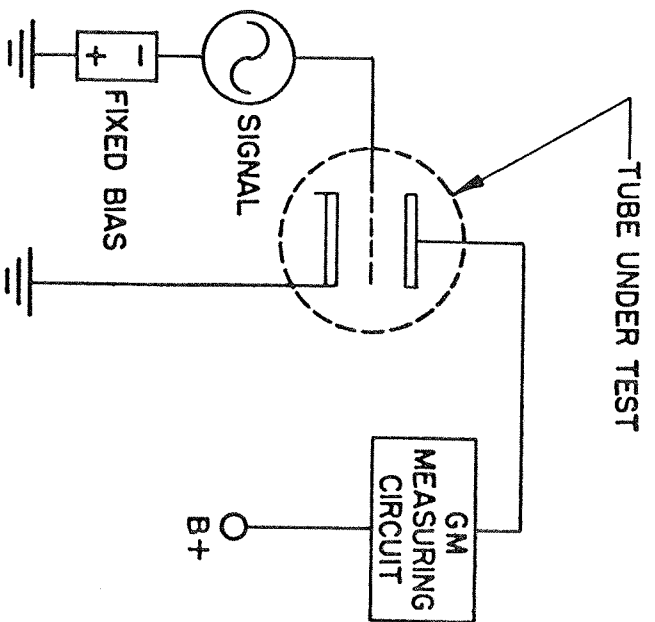

FIXED-BIAS GM TEST CIRCUIT

TRIODE TEST CIRCUITS

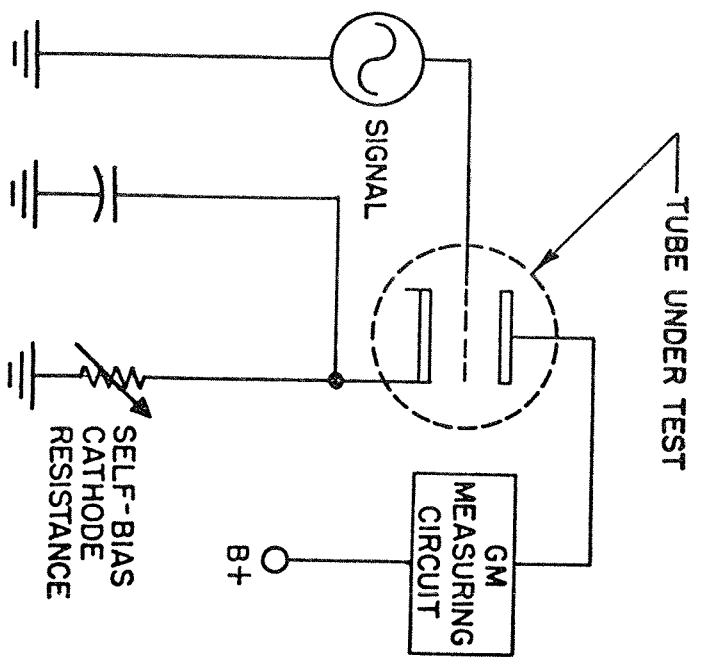

SELF-BIAS GM TEST CIRCUIT

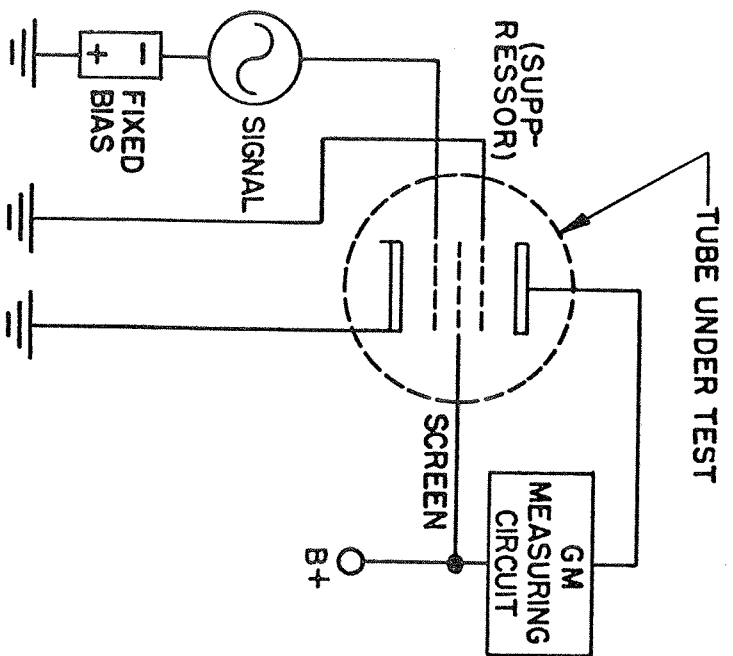

FIXED-BIAS GM TEST CIRCUIT

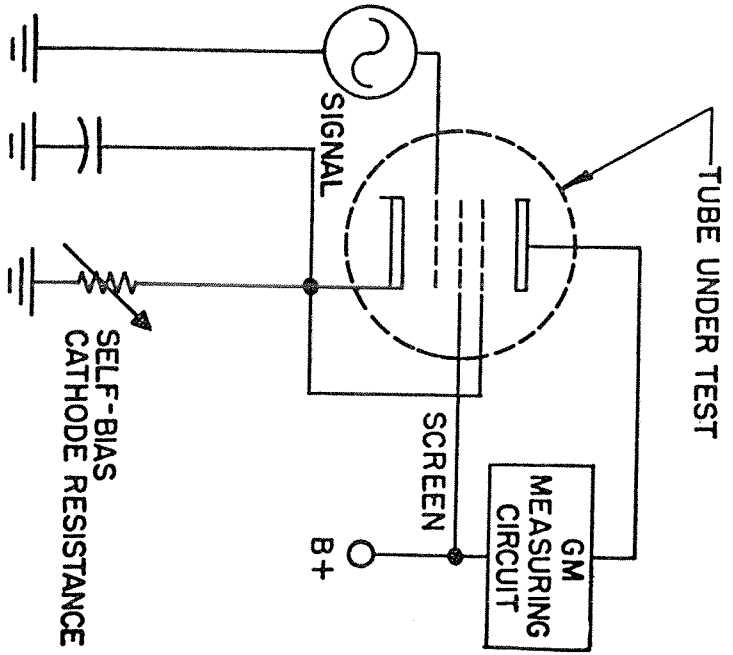

SELF-BIAS GM TEST CIRCUIT

PENTODE TEST CIRCUITS

Figure 6 - Test Circuits for Amplifying Tubes

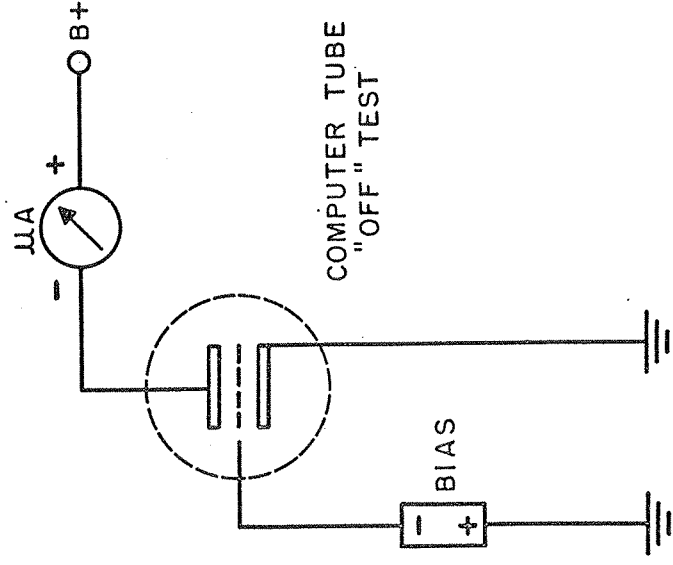
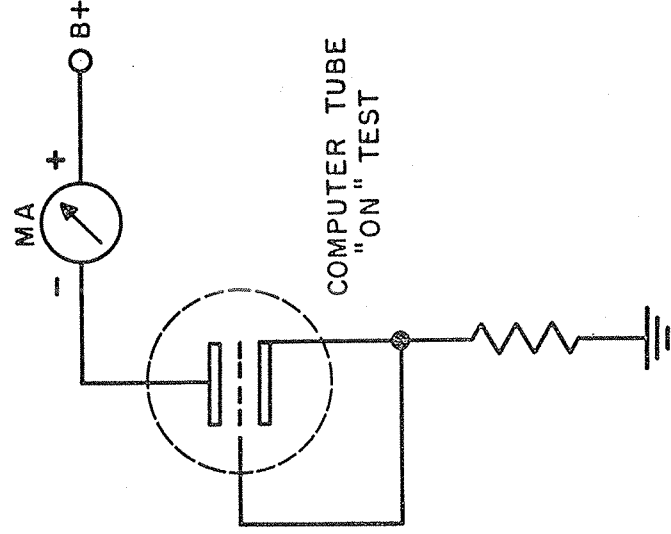
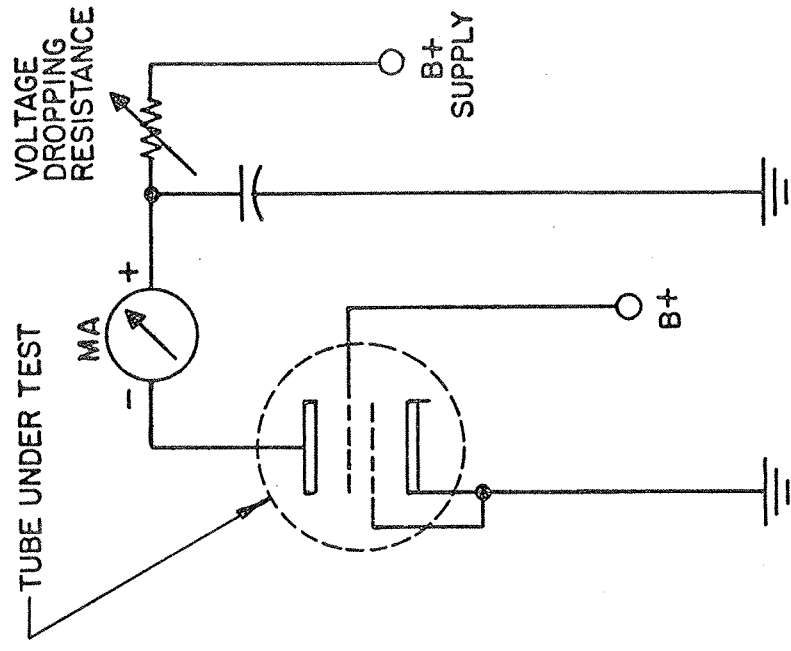
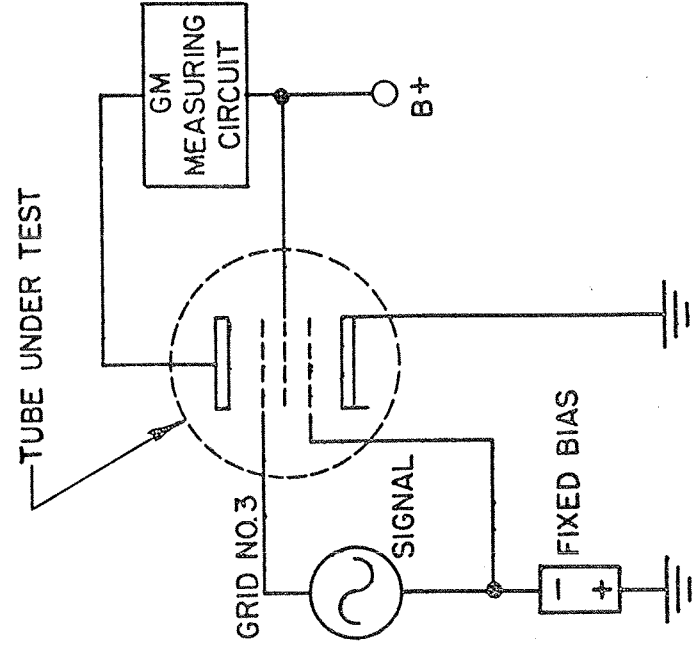
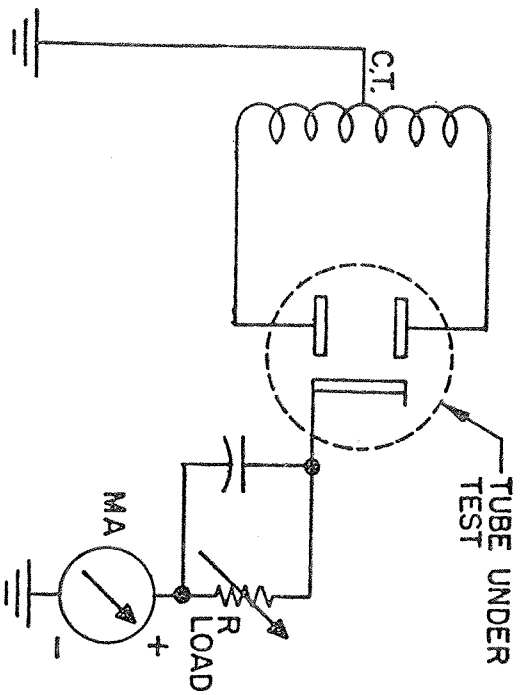
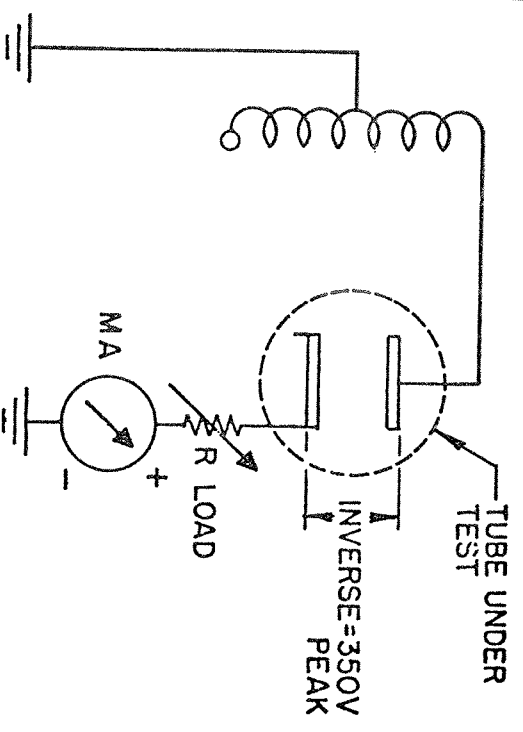

Figure 7 - Special test Circuits



Full Wave Rectifier Test Circuit



Half Wave Rectifier Test Circuit

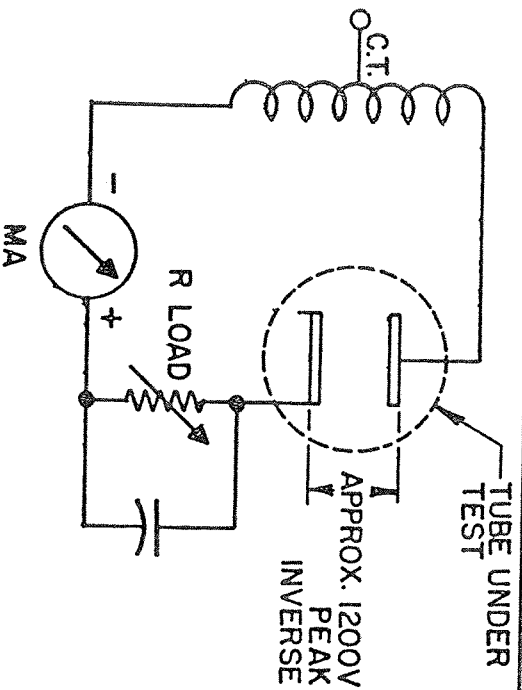

High Voltage Rectifier Test Circuit

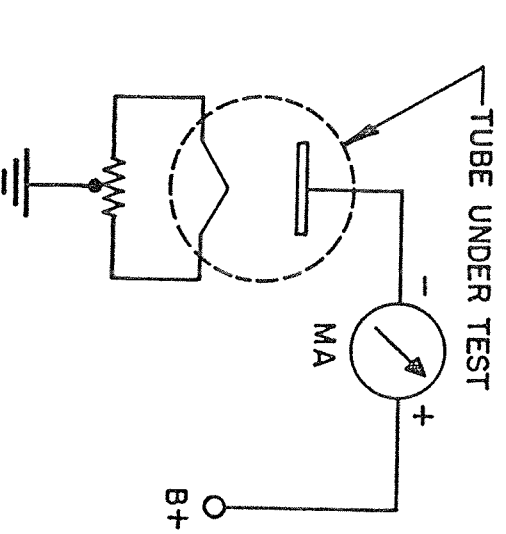

High Voltage Diode Test Circuit

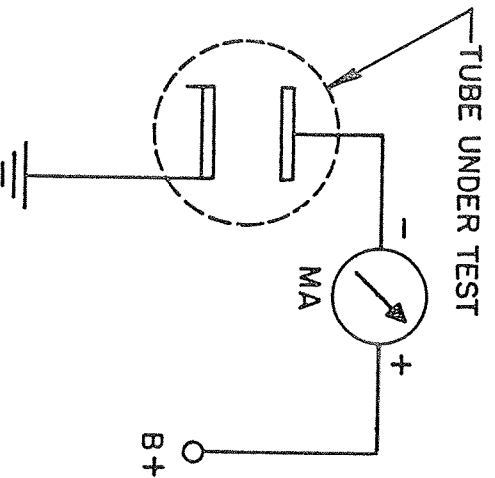

High Perveance Diode Test Circuit

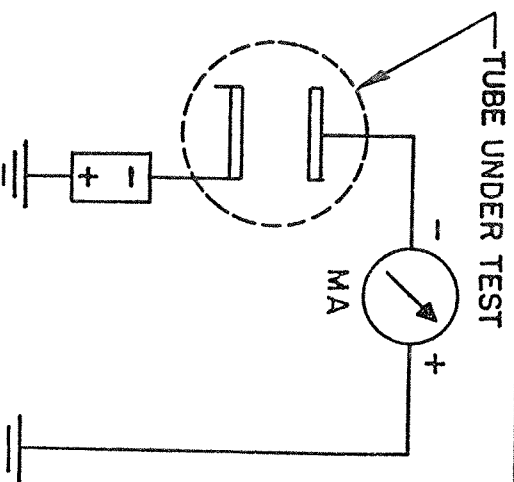

Low Perveance Diode Section Test

Figure 8 - Basic Types of Diode Test Circuits

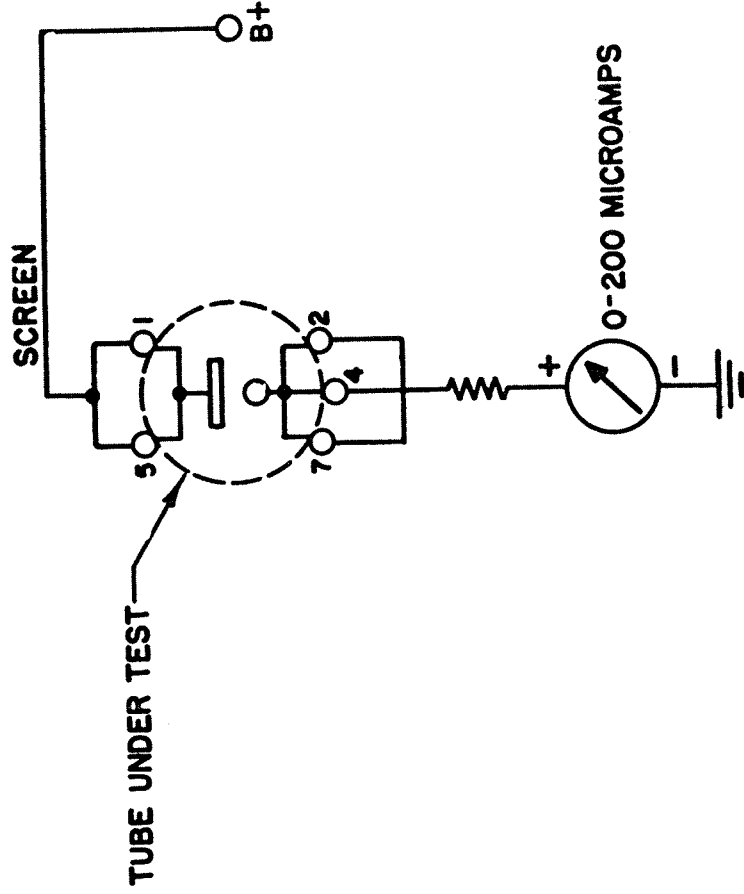
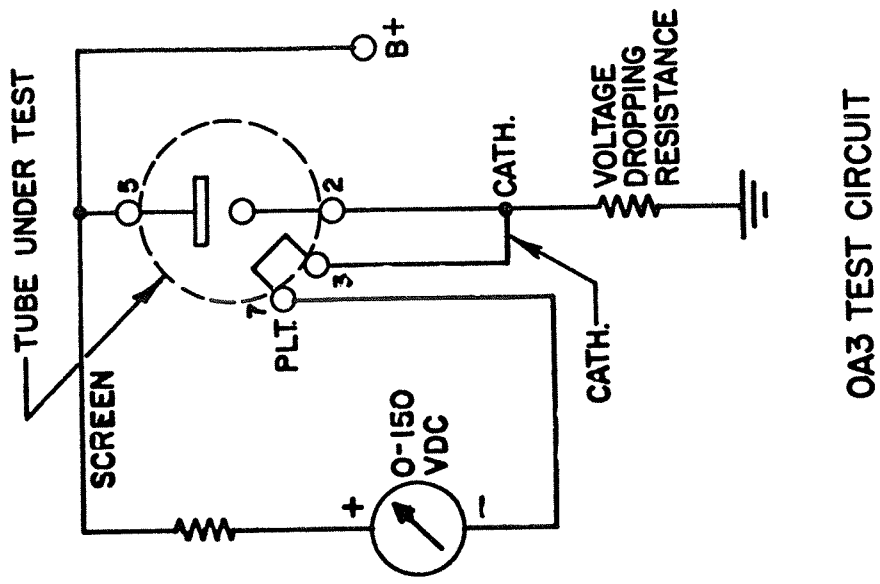
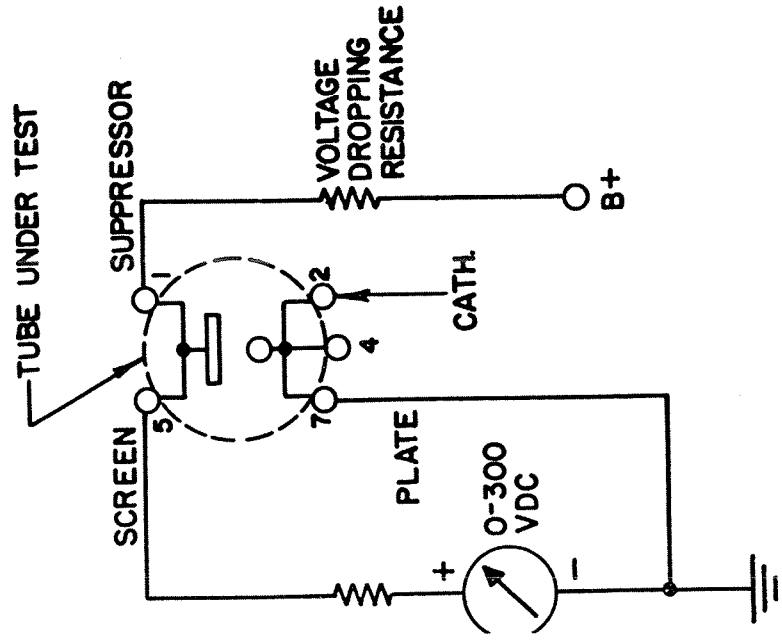

OA2, OB2 LEAKAGE TEST CIRCUIT

Figure 9 - Voltage Regulator Test Circuits

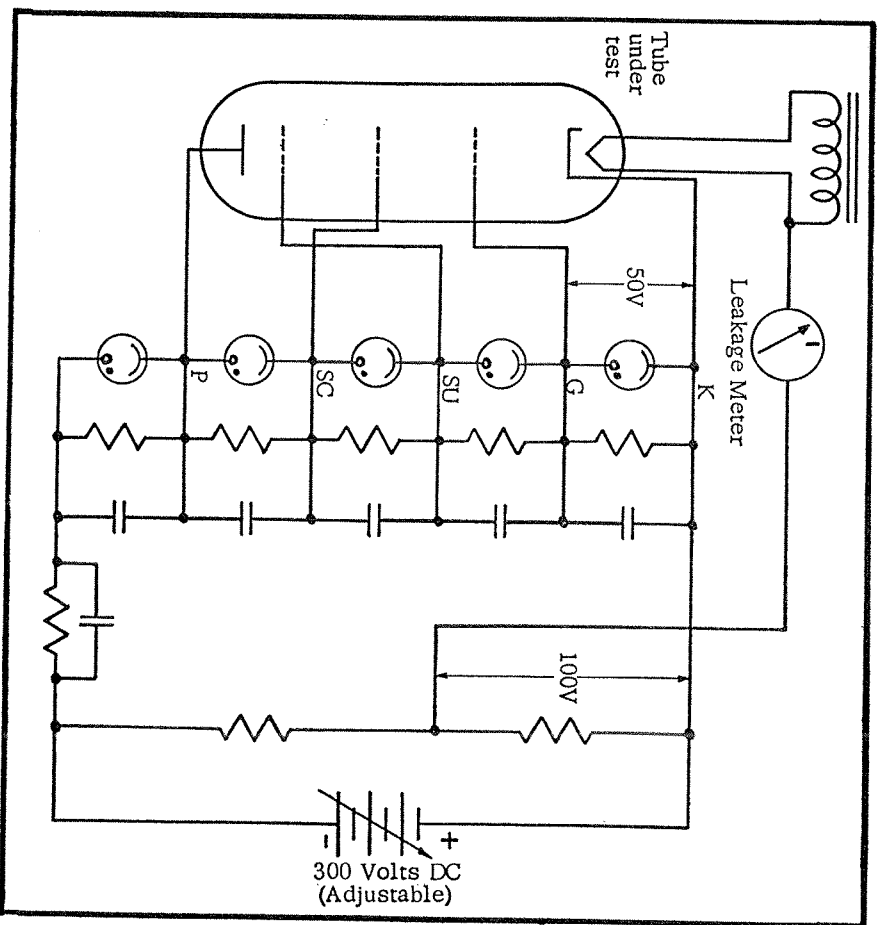

Figure 10 - Shorts and Cathode-to-Filament Leakage Test Circuit

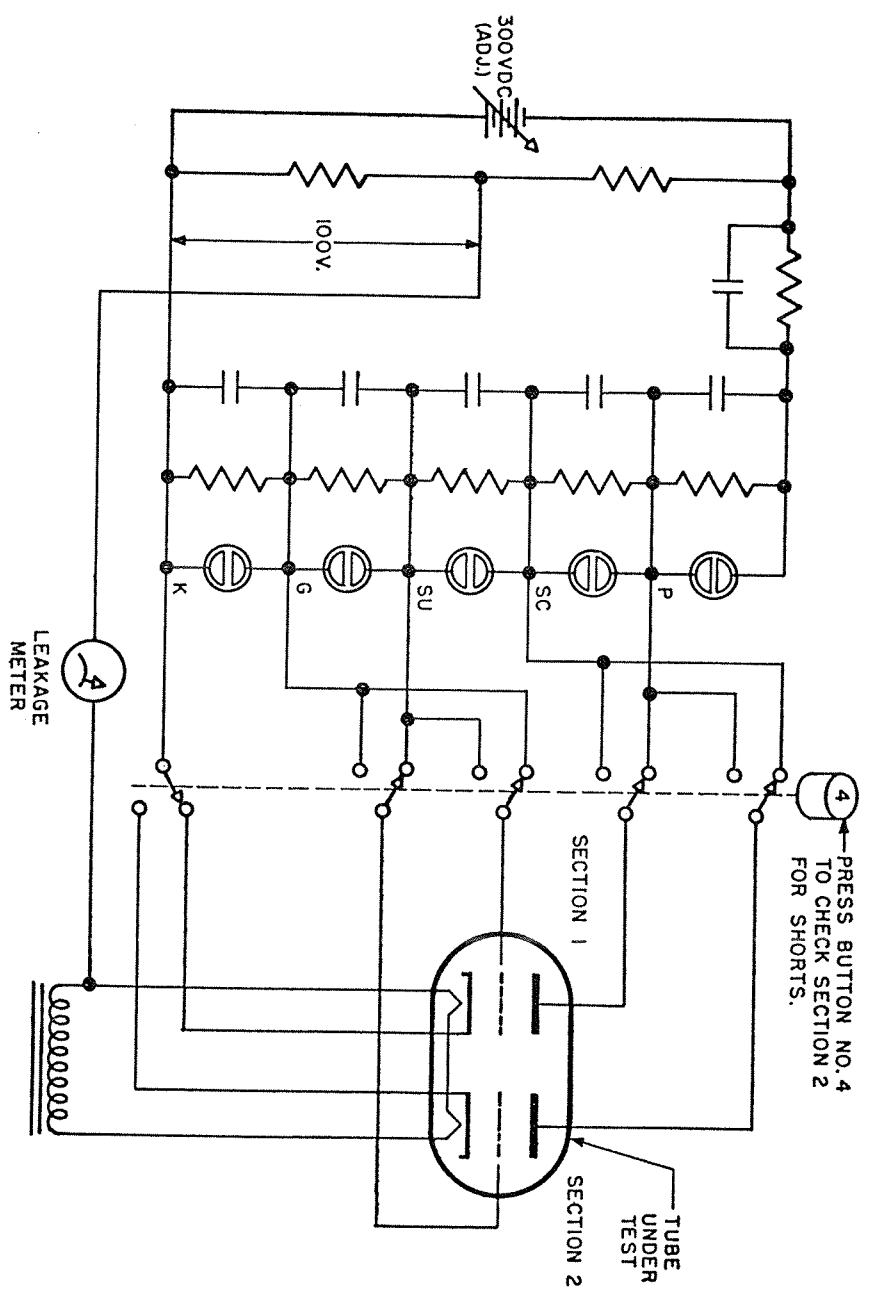

Figure 11 - Shorts and Cathode-to-Filament Leakage Test Circuit (Multi-Section Tube)

5.11 The second rectifier test is for half-wave tubes in which the load resistance is adjusted in series with the milliammeter without the filter capacitor. The circuit for this test is shown in figure 8.

5.12 High voltage type rectifiers are tested on a circuit similar to that shown. High voltage ac is applied from the plate to the cathode in series with a load resistance and its filter capacitor and then through the dc milliammeter. A low voltage across the tube would reveal its emission characteristics but by using the load capacitor it is possible to develop approximately 1200 volts peak inverse which will show arcing conditions.

5.13 A high voltage diode may be checked for emission by the circuit shown in figure 8. The regulated power supply is connected directly across the tube and the current is metered through the tube. The reject value for this type of tube is fairly low and since the reject point is midscale on the meter most tubes will read near full scale.

5.14 Another type of emission circuit as shown in figure 8 is mainly for use in testing high perveance detector diodes. Ten volts dc is applied across the tube with the milliammeter in series. This type of tube is rated for about 60 MA and is rejected at about 25% of this figure. Low perveance diodes are tested the same way except it is necessary to use a higher impedance 10V supply. Low perveance tubes are rated about 2 MA with a reject point of about 0.3 MA.

5.15 Voltage regulator tubes are checked for continuity, leakage, voltage drop at low current and voltage drop at high current. The regulator tubes are tested by using four cards, one of which is an instruction card that is not inserted into the tester. The number 2 card measures leakage as shown in figure 9.

The tube jumpers are connected together and the voltage is applied across the tube in series with the meter. The reject point for these tubes is 10% of full scale. Card 3 is for measuring the voltage drop across the tube at low current while card 4 measures the drop at high current. The difference between the meter readings using these two cards is the regulating ability of the tube. The nearer to zero the difference the better the regulation. The number 1 card has test information to guide the operator in judging test results. Typical VR test circuits are shown in figure 9. The shorts test lamps are used to check jumper continuity. The left lamp will glow on cards 3 and 4 indicating a plate to cathode short. Should a tube have discontinuity no reading will be obtained on the tester meter when button 2 is pressed. Normally a good tube will read half scale on the meter.

5.16 Short Test. When a tube is inserted into the set for test, it is immediately subjected to a gradient type of DC voltage as illustrated in figures 10 and 11, which show the short test circuits for typical single and multi-sections. This voltage gradient is adjusted so that all five neon lamps are extinguished unless a resistive path exists across them. The voltage gradient appears across a series of relaxation oscillator circuits, composed of a capacitor and resistor connected to each lamp and tube element. The short resistance determines the charging rate of the capacitor. The capacitor charges to the lamp starting voltage then discharges through the lamp. The cycle then repeats. The circuit is thus set up so that the lamps will flash intermittently for a high resistance and glow steadily for a low resistance short. The DC voltage is polarized in such a way that if the tube exhibits grid emission the lamps will also flash. The sensitivity of the shorts test circuit from grid to cathode is 1 megohm indication and 2 megohms no indication. The sensitivity of the short test for various interelement shorts is shown in figure 12. A separate pushbutton in the auxiliary compartment is used to check critical grid-to-cathode shorts at a sensitivity of 10 megohms indication and 20 megohms no indication. If the neon short test lamps indicate that an interelement short exists, the chart in figure 12 should be used as an aid in identifying the shorted elements. Certain diodes, due to a shield connection in the test circuit, may indicate a short from grid or suppressor to the other tube elements. Damper diodes will show a plate-to-cathode short as a screen-to-cathode short due to the test circuit arrangement.

5.17 Leakage Test. This test is made by placing a microammeter in series with the heater and cathode, see figure 10. A system of shunts is available so that the reject point can be set up individually for the various types of tubes. The tester meter scale has definite reject point but actual current may be as low as 10 microamperes or as high as 150 microamperes depending on the type of tube. By using this system nearly any handbook condition can be duplicated. The amount of leakage tolerable is of course dependent on the application. As an example, a tube used in a cathode follower circuit with high cathode resistance may have to be rejected with as little as 10 microamperes of cathode to filament leakage. On the other hand a direct cathode to filament short in a tube used in a grounded cathode circuit may be insufficient cause for rejection.

5.18 Gas Test. Button 3 is used to test the tube for grid current due to gas. Pressing button 3 also actuates the button 2 through an interlock which operates the tube under normal bias and plate current conditions. If gas ions are present in the vacuum they will migrate to the negative grid and cause a current to flow which is read on the number 3 scale of the meter. The allowable grid current, due to gas, ranges from .5 to 3 microamps depending on the tube type. Of course, tubes having no grids cannot be tested for gas in this manner. In all of the tube tests a zero bias grid voltage is avoided because it would cause the meter to deflect to the left or opposite to that of gas current due to contact potential.

If the meter deflection is beyond the green sector of the meter under #3 test, the amplifier tube has a grid current in excess of 3 microamperes and it is definitely of no useful service. This reject point is based upon manufacturers' specifications for a large number of tubes. However, in circuits where there is a high grid impedance present even a 1/2 microampere grid current is harmful, therefore any up scale deflection under #3 test should be regarded with question for a given tube.

PENTODE SHORT OR LEAKAGE PATH	NEON LAMPS					FULL WAVE RECTIFIER OR DUAL DIODE AND DUAL TRIODE SHORT OR LEAKAGE PATH *	MAXIMUM SENSITIVITY REGION (MEGOHMS)
	P	SC	SU	G	K		
CATH - GRID	X	X	X	X		CATH - GRID - SECT. 1	1-2
CATH - SUPR.	X	X	X			CATH, SECT.1 - GRID, SECT.2	5-10
CATH - SCR.N.	X	X				CATH, SECT.1 - PLT, SECT.2	15-30
CATH - PLT.	X					CATH - PLT., SECT.1	30-60
GRID - SUPR.	X	X	X			GRID, SECT.1 - GRID, SECT.2	1-2
GRID - SCR.N.	X	X				GRID, SECT.1 - PLT, SECT.2	5-10
GRID - PLT.	X				X	GRID - PLT, SECT.1	15-30
SUPR - SCR.N.	X	X		X	X	GRID - PLT, SECT.2	1-2
SUPR - PLT.	X			X	X	PLT, SECT.1 - GRID, SECT.2	5-10
SCR.N - PLT.	X		X	X	X	PLT, SECT.1 - PLT, SECT.2	1-2

\*CHART SHOWS INDICATIONS WITH BUTTON NO.4 NOT PRESSED.  
WHEN BUTTON NO.4 IS PRESSED, SECTION 1 BECOMES SECTION 2  
AND SECTION 2 BECOMES SECTION 1. (SEE FIG.11)

THE (X) MARK INDICATES A GLOWING LAMP.

Figure 12 - Interelement Shorts Identification



## B. Circuit Description

5. 19 For convenience the schematic circuit is divided into 3 parts. The power supply is shown on Sheet 1. Automatic circuit selection is on Sheet 2. Connections to the tube sockets, push buttons, shorts test and miscellaneous circuits are on Sheet 3.
5. 20 The power supply, Sheet 1, has two transformers (filament and power) which supply the various voltages required. Both sides of the main power line are fused for protection of the transformers against large overloads.
5. 21 The majority of the components of the power supply are protected against overload by two methods. First, the main B+ supply is protected by a circuit consisting of a line slave relay, K101, and an overload sensing reedrelay, K102. The contacts of the reedrelay are connected across the coil of the line slave relay. When an overload occurs in the main B+ supply, the reedrelay contacts close, shorting out the coil on the line slave relay. The line slave relay becomes de-energized, opening both sides of the input power line. Secondly, overloads which cause the meter needle to deflect excessively, either up-scale or down-scale, will be detected by contacts in the meter. These contacts energize another reedrelay, K104, which also will cause the line slave relay to de-energize, opening both sides of the power line. (See Section 6. 13 and Figure 16 ).
5. 22 The filament transformer is protected by a 100 watt electric light bulb in series with the primary. This lamp functions as a non-linear resistance network to assure that the filament drain never exceeds 20 watts. When a direct short circuit is applied to the secondary of this transformer the lamp absorbs the overload.
5. 23 The filament transformer supplies ac voltages for tubes under test. These voltages are reduced 10% through a switch in the primary winding for cathode activity tests. The filament transformer primary also has a selector switch that is used to compensate for variations in line voltage over a range of 105 to 125 volts. This switch may be used for critical tests or for tubes having heavy filament drains. However, for normal tests it is left at the 115 volt point.
5. 24 The tester has three operational B+ supplies which are: the main B+, auxiliary B+ and unregulated B+. The main B+ is used as the plate and screen supply for the tube under test. Referring to the power supply schematic, the 250V taps of the power transformer supply the 5U4GB rectifier which is in turn connected to the plate of the 6CD6 series regulator tube. The pentode section of the 6AW8A is an amplifier for the feedback loop which controls the grid of the 6CD6 by sensing the output voltage called for or by sensing a need for regulation because of voltage change. The triode section of the 6AW8A is a voltage reference tube to establish a constant potential at the cathode of the pentode section. The 6C4WA is a low impedance control tube for the screen of the series regulator and is driven from the plate circuit of the amplifier tube. Both grids of the series regulator are being driven but the control is directly to the screen by a voltage from the 6203 through the 6C4WA control tube. The only filtering is through the screen supply from the 6203. The output voltage from this supply is controlled by the group of resistors in series which is shown on Schematic Sheet 2. By closing various switch combinations a voltage from 10 volts to 260 volts in 10 volt steps may be selected. The current drain of the voltage selection network is constant at 1 MA.
5. 25 The auxiliary B+ supply is used primarily in cold cathode tube tests but may be used for other special data requirements. It is supplied by the 6203 rectifier with the 6CL6 being used as the series regulator. The pentode section of the 6AU8 is the loop amplifier for the feedback circuit. The circuit is manually controlled by the auxiliary B+ potentiometer. It is monitored by pressing a button and reading the tester meter. The voltage may be interpreted by multiplying the meter reading by three (the monitoring meter reads 300 volts full scale). The supply is fused and does not operate through the protective relay circuit. The supply is variable from 30 volts to 300 volts at currents up to 30 MA.

5.26 The unregulated B+ is obtained from the cathode of the 5U4GB through a simple filter. It provides approximately 350 volts which varies with line and load. It is used in tests where the voltage is immaterial but a high current is desired. An example of this would be in a high emission "knee" test of a pulse power pentode.

5.27 The tester has a low current regulated supply of approximately plus 150 volts which has four uses as follows: a positive reference grid supply, a voltage for operating the reed-relay, K104, for the meter contacts, a part of the supply for the shorts test, and a part of the supply for the heater to cathode leakage test. It is derived from the 6203 through the 6AU8 triode connected as a shunt regulator. A feedback system of neon lamps establishes the +150 volts. The positive reference is taken off a resistive network from 0 volts to +150 volts. This supply can be used as a reference voltage for the grid of a tube under test. It allows the use of larger self bias resistance while the equivalent tube is still negative.

5.28 The minus 150 volt supply is stabilized and is the basic reference voltage for all other regulator supplies. It forms the negative potential for the shorts test and heater to cathode leakage test circuits and is used as the bias supply. It also supplies the voltage for the hold coil on reed-relay, K104, in the protective circuit. It is derived from 275 volts each side of the center tap and through rectifiers CR101 and CR102. The OA2WA shunt regulator controls the minus supply and is the voltage reference for all regulated supplies.

5.29 The fixed bias supply, for tubes under test, is obtained directly across the OA2WA tube. It has a range of 0.1 volt to 100V in approximately 0.1 volt steps by using a decade resistor system which is shown on Schematic Sheet 2.

5.30 The bias off supply is similar to the fixed bias supply. It is used to hold off a section of a tube while another section is being tested. An example of its use would be for testing a dual pentode with common screen and common cathode.

5.31 The power supply furnishes a grid signal of 0.222 volts from the 10 volt winding of the transformer and an ac bridge type regulating circuit:

5.32 Other voltages from the power supply are:

- (a) 250 volts ac used mainly for rectifier tests
- (b) 10 volts for driving the transconductance bridge
- (c) Filament supplies for tubes within the power supply

5.33 The secondary of the transformer which supplies voltages to the filaments of tubes under test is shown on Schematic Sheet 2. These voltages may be varied from 0.1 volt to 119.9 volts in 0.1 volt steps. Sheet 2 also shows a full wave bridge rectifier which supplies up to 1.0 ampere of dc for filamentary type tubes. This DC filament supply is fused and does not depend on the protective relay circuit for protection.

5.34 Referring to Schematic Sheet #2 it may be seen that it is largely composed of single pole single throw switches and resistors. These switches are labelled according to their position in the card switch. By closing various combinations of these switches, the program card automatically selects the circuits to be used on the tube under test.

5.35 The group of switches and resistors (R215, R229 and R231) along the bottom of the sheet form a decade resistance network. This network is used for applying the proper fixed bias to the tube under test up to 100 volts in 0.1 volt steps by closing various switches to short out unwanted resistors. This decade system has many uses other than negative grid bias. By referring to the circuit theory section it may be seen that it is used as cathode resistance in self bias tests; it is applied to both control grids in heptodes and is often used as voltage dropping resistance in other tests.

5.36 Referring again to schematic sheet 2 there is another group of switches and resistors

(R234 and R240) located in the lower left hand corner of the drawing. This group of switches and resistors is used to establish the output voltage of the regulated B+ supply. The following table lists the switch combinations which are closed to obtain the various output voltages:

<u>VOLTS</u>	<u>CLOSE SWITCH</u>	<u>VOLTS</u>	<u>CLOSE SWITCH</u>
10	D-17, L-3, L-4	140	B-17, L-4
20	D-17, E-17, L-4	150	B-17, E-17
30	D-17, L-4	160	B-17
40	D-17, E-17	170	L-2, L-3, L-4
50	D-17	180	L-2, E-17, L-4
60	C-17, E-17, L-3, L-4	190	L-2, L-4
70	C-17, L-3, L-4	200	L-2, E-17
80	C-17, E-17, L-4	210	L-2
90	C-17, L-4	220	L-3, L-4
100	C-17, E-17	230	E-17, L-4
110	C-17	240	L-4
120	B-17, L-3, L-4	250	E-17
130	B-17, E-17, L-4	260	None

5.37 The group of switches and resistors (R203 to R205) is used as shunts to the meter for establishing sensitivity of the leakage test.

5.38 The group of switches and resistors in the center of schematic sheet 2 at the top, is used as shunts and multipliers for the meter when used in the quality test. These shunts and multipliers make it possible to provide broad ranges of sensitivities as discussed in the section on circuit theory.

5.39 The group of components in the center of schematic sheet 2 forms the Gm bridge circuit. For purposes of analyzing this circuit consider the meter and its shunts connected across condensers C401 and C402 and a 10 volt transformer winding connected across C403. The transformer winding acts as a bias source to alternately turn on diodes CR401 and CR403 while turning off diodes CR402 and CR404 and vice versa. By this action all the DC current that enters the bottom end of the bridge is chopped into alternating current, sent through the meter and its shunts, and put back together again into a DC current as it flows out of the top of the bridge. The meter, which is a direct current average reading device, will respond to the difference in the magnitude of the two alternating current pulses. By modulating the grid of the tube under test with an AC signal of the same phase relationship as the 10 volt bias winding in the bridge, these two current pulses will be of different magnitude and the meter can be calibrated directly in micromhos inasmuch as it is responding to a minute change in plate current with minute change in grid voltage which is by definition, transconductance. The resistor network, consisting of R402 to R406, is of a high impedance nature and is used to balance out the back resistance characteristics of the diodes. Potentiometer R405 is then called Gm balance low current. Potentiometer R401 is of very low value and is in series with the diodes. This potentiometer is called Gm balance high current and is used to balance the bridge for the forward characteristic of the diodes at a high current. This circuit is separately fused in order to prevent damage to the bridge under certain short circuit conditions that cannot be sensed by the relay protection circuit.

5.40 The rest of the contact groups appearing on sheet 2 are used to establish the test configuration and to control miscellaneous other circuits.

5.41 Sheet 3 of the schematic contains a group of card switch contacts which provide connections to the pins of the tube under test. The short, leakage and gas test circuits are shown on this figure but are completely described in 5.16, 5.17 and 5.18. The remainder of sheet 3 consists of the push button and meter circuits. It should be noted that when button 3 (GAS) is pressed it also actuates button 2 (QUALITY). This maintains normal operating conditions on the tube but switches the meter to the grid circuit.

C. Amplifier Tube Test Circuit Programming

5.42 With the help of a tube manual as published by tube manufacturers the following instructions will enable establishment of a desired test circuit for an amplifier tube. Wiring diagrams, Sheet 2 of 4, Sheet 3 of 4 and Sheet 4 of 4 at the back of this book should be studied before any circuits are begun.

5.43 Test Socket Pin Connections. The pins of the various test sockets are wired in parallel according to the standard EIA designation. See Wiring Diagram Sheet 4 of 4. It will be noticed that the top cap connector is identified as pin 10. The following table may be used to connect the supply voltages to the desired tube socket pins. Note also that the letter "I" is omitted.

Socket Pin Number	Cardmatic Switch Column Letter
1	A
2	B
3	C
4	D
5	E
6	F
7	G
8	H
9	J
CAP	K

5.44 The Cardmatic switch rows 1 and 2 are the filament (or heater) supply lines. Row 1 is the filament plus (+) supply and Row 2 is the filament minus (-) supply. One letter of each of these rows must be chosen to connect the desired pins to the filament voltage. If a heater is desired to be connected in parallel then two letters of one of these rows must be used with one of the other row. Never close the same switch letters on Rows 1 and 2 as the filament voltage source will be shorted; that is, never close A-1, A-2; B-1, B-2; C-1, C-2, etc. Some common heater pins are: 2 and 7 - close B-1 and G-2; 3 and 4 - close C-1 and D-2, 4 and 5 - close D-1 and E-2. An example of a 12AU7 heater in parallel would be: close D-1, E-1 and J-2 or J-1, D-2 and E-2.

5.45 The cardmatic switch row 3 is the control grid line. A negative or a positive bias voltage may be applied to this line with or without the 0.222 volt signal. An example of connecting test socket pin 4 to this line would be to close D-3.

5.46 The Cardmatic switch row 4 is the cathode line. The line may be connected to the "0" volts floating ground; it may be by-passed with a 1000 microfarad capacitor to the "0" volts line; it may be connected to the suppressor line; it may be connected to the decade resistors which act as a load, a grid bias divider, or a self bias resistor; and it may be by-passed by a 4 microfarad capacitor to the opposite end of the decade resistors. An example of connecting test socket pin 8 to this line would be to close H-4.

5.47 The Cardmatic switch row 5 is the screen line. This line may be connected to the regulated B+ source, to the "bottom" of the Gm bridge, to the "top" of the Gm bridge, to one end of a 500 volt AC center-tapped transformer winding or to an auxiliary B+ (0 to 300 VDC knob controlled) supply. An example of connecting test socket pin 6 to this line would be to close F-5.

5.48 The Cardmatic switch row 6 is the suppressor line and four possible connections may provide different voltages to it. By closing L-16 the suppressor is tied directly to the cathode, by closing K-16 the suppressor is returned to the "0" volts or floating ground reference point, by closing J-16 the suppressor is connected to a high negative bias (approximately 50 VDC when C-16 is also closed) which is useful in twin diode tests, and by closing H-16 the same bias

may be applied to the suppressor grid as the control grid except without the signal. An example of connecting test socket pin 7 to this line would be to close G-6.

5.49 The Cardmatic switch row 7 is the plate line. Switch J-17 places the negative terminal of the meter to this line for DC current measurements, switch K-17 connects the "top" of the Gm bridge to this line and switch L-17 connects the remaining end (see para. 5.47) of the 500 volt AC center-tapped transformer winding for rectifier tests.

5.50 The Cardmatic switch row 8 is used for special circuits where two tube pins may be connected without a short test voltage or any other voltage directly applied. This line may be returned to the "0" volts reference point without the transient effect of button No. 2. Also, in twin diode and triode testing, this line may function as the cathode line when button No. 4 interchanges rows 4 and 8.

5.51 Twin Tube Section Circuitry. For a twin triode such as a 12AU7 the first section (pins 6, 7, 8) should be treated as a single triode where row 7 is to be used for the plate, row 3 is to be used for the grid and row 4 is to be used for the cathode. Since Button No. 4 interchanges plate and screen (row 7 and row 5), grid and suppressor (row 3 and row 6) and cathode and row 8 (row 4 and row 8), the second triode elements must be connected as follows: the plate is connected to row 5, the grid is connected to row 6 and the cathode is connected to row 8. See Figure 11. For this dual testing the lamp next to Button No. 4 should be lighted. Close J-8. To establish the function of row 8 as a cathode close K-8. If switch J-15 is used the regulated B+ voltage will be on the second section plate. Therefore consideration must be given to the suppressor supply (second section grid). When switch C-16 and the associated circuitry for the negative grid bias is used (see paragraph 5.57) switch J-16 will provide about 50 VDC negative on the suppressor row 6. This voltage may be used for cutting off plate current in the untested section in case the respective cathode is returned to the "zero volts" or floating ground point. One such case may be when a 6J6, which has a common cathode, is desired to be tested one section independent of the other. When the same cathode pin is to be used on the second section test close the switch in row 8 that is in the same column as that in row 4. In the case of the 6J6 basing close G-4 and G-8.

If it is desired to bias off the untested section of a twin triode such as the 6J6 while the section under test is in a self-bias circuit, then switch C-16 must be closed to be assured of 50 volts and not 150 volts negative through switch J-16 to the suppressor row 6. Switch C-15 will provide the "ground" end connection of the self-bias resistance through switch A-16.

5.52 Heater Voltages. The AC heater or filament voltages are obtained from the sum of three decade steps: tens of volts, units of volts and tenths of volts. The voltage chosen is applied to row 1 and row 2 to pins of a tube when switches A-12 and B-15 are closed. One switch of each of the three decades must be closed for the desired voltage.

<u>Volts</u>	<u>Switch</u>	<u>Volts</u>	<u>Switch</u>	<u>Volts</u>	<u>Switch</u>
0:	A-9	0:	A-10	0.0:	A-11
10:	B-9	1:	B-10	0.1:	B-11
20:	C-9	2:	C-10	0.2:	C-11
30:	D-9	3:	D-10	0.3:	D-11
40:	E-9	4:	E-10	0.4:	E-11
50:	F-9	5:	F-10	0.5:	F-11
60:	G-9	6:	G-10	0.6:	G-11
70:	H-9	7:	H-10	0.7:	H-11
80:	J-9	8:	J-10	0.8:	J-11
90:	K-9	9:	K-10	0.9:	K-11
100:	L-9				
110:	L-10				

For DC filament voltages A-12 and B-15 must be open, with K-1 and K-2 closed. Since the

voltage drop across the silicon full-wave bridge rectifier is proportional to the load current and since this drop is an appreciable percentage of the desired output voltage it becomes simpler to meter the DC voltage across the filament pins of a tube while adjusting the AC winding taps. The silicon diodes are rated at 0.5 ampere and the circuit is fused for 1 ampere. To properly tie in the filament to the cathode line the same column lettered switch in row 4 should be closed as is closed in row 2. This will short the 50 ohms that is used at other times in reaching the electrical center of AC heated tubes. This short will also appear as a heater-cathode short on the meter scale and therefore switch G-17 must be closed to eliminate the DC heater-cathode leakage test voltage.

5.53 Heater-Cathode Leakage Meter Sensitivities. Whenever G-17 is open, Cardmatic switch rows 1 and 2 are used for a heater and row 4 is used for a cathode, a heater-cathode leakage test is being applied which consists of 100 VDC in series with a microammeter.

At rejection (10% of full scale) the following meter values are obtained:

A-14, B-14, C-14 each open	10 microamperes
A-14 only closed	20 microamperes
B-14 only closed	50 microamperes
A-14, B-14 each closed	70 microamperes
C-14 only closed	100 microamperes
B-14, C-14 each closed	150 microamperes

5.54 Regulated B+ Supply. Refer to paragraph 5.36 to set the regulated B+ supply from 10 volts to 260 volts at any 10 volt level. The minimum allowable output current of this supply depends upon three conditions: (1) maximum plate dissipation of the passing tube, (2) characteristics of the passing tube under low line voltage and (3) maximum available voltage in the tester. Refer to the following tabulation for maximum allowable currents:

Regulated B+ Supply Volts	Maximum Current (MA)	Regulated B+ Supply Volts	Maximum Current (MA)
10	69	140	140
20	72	150	140
30	75	160	129
40	76	170	120
50	80	180	110
60	82	190	102
70	86	200	94
80	90	210	85
90	95	220	77
100	100	230	68
110	110	240	60
120	119	250	50
130	129	260	42

These regulated B+ voltages are available to be used on the screen (row 5) and/or plate (row 7) for plate current or mutual conductance tests. To connect the regulated B+ to the screen line (row 5) close J-15. To connect the B+ to one end of the Gm bridge close J-15 and H-15 and to complete the Gm bridge circuit to the plate (row 7) close K-17, A-13, B-13 and H-13.

5.55 Micromhos Full Scale Meter Sensitivities. Switches L-7, L-12, C-12, D-12, E-12, F-12, G-12, H-12, J-12, and K-12 determine the full scale micromho value of the meter. Since there are over 500 ranges of micromhos only some of the more useful values are tabulated in the following:

Full Scale Micromhos	Close	Full Scale Micromhos	Close
500	L-12	4500	F, H, L-12
600	C, L-12	5000	C, E, F, H, L-12
700	D, L-12	6000	C, D, E, G, H, L-12
800	C, D, L-12	7000	C, J, L-12
900	E, L-12	8000	C, D, F, J, L-12
1000	C, E, L-12	9000	C, E, G, J, L-12
1200	C, D, E, L-12	10,000	C, D, E, F, G, J, L-12
1500	D, F, L-12	12,000	C, D, G, H, J, L-12
1800	C, E, F, L-12	15,000	C, C, G, L, L-12
2000	C, D, E, F, L-12	20,000	C, D, J, K, L-12
2500	E, G, L-12	25,000	C, E, G, H, J, K, L-12
3000	C, F, G, L-12	40,000	C, D, E, F, J, L-7
3500	D, E, F, G, L-12	60,000	C, D, E, G, H, J, L-7
4000	C, D, H, L-12	100,000	C, D, E, J, K, L-7

The full scale value in micromhos may also be determined from the following when switch L-12 is closed:

Gm = 500 plus 100 times the choice number and  
Choice No. = Gm less 500 divided by 100.

A choice number is an arbitrary assignment of a number to a meter shunt resistance so that a convenient mathematical relationship exists for the series of combinations. When a desired meter shunt resistance is one of the eight resistors the choice number is identified as "primary". A "secondary" choice number is then one that is made up of primary choice numbers.

The primary choice numbers are related to the meter shunt resistors according to the binary system:

Primary Choice No.	Meter Shunt Resistor	Switch Closed (with L-12)
1	A (1280Ω)	C-12
2	B (640Ω)	D-12
4	C (320Ω)	E-12
8	D (160Ω)	F-12
16	E (80Ω)	G-12
32	F (40Ω)	H-12
64	G (20Ω)	J-12
128	H (10Ω)	K-12

Choice No. zero is obtained when no meter shunt resistor is used. The primary choice numbers may be added to form secondary choice numbers. Secondary Choice No. 31, for example, consists of the summation of primary choice Nos. 1, 2, 4, 8 and 16. Secondary choice numbers consist of combinations of only single primary choice numbers. A primary choice number cannot be used twice, as inspection of switching will reveal. To determine the primary choice numbers for a given secondary choice number begin with the highest possible primary choice number and subtract, repeating this procedure until all the primary choice numbers are found. For example, the primary choice numbers for choice number 51 are desired. Since 51 is between 32 and 64, subtract 32 (use Resistor "F", switch H-12) which leaves 19. This number is between 16 and 32: subtract 16 (use resistor "E", switch G-12) which leaves 3. This number is between 2 and 4: subtract 2 (use resistor "B", switch D-12) which leaves 1 (use resistor "A", switch C-12). Choice number 51 is then made up of 1, 2, 16 and 32, and corresponds with the use of meter shunts "A" - 1280Ω, "B" - 640Ω, "E" - 80Ω and "F" - 40Ω. The full scale value in micromhos for choice number 51 is then:

$$G_m = 500 + 100 \times 51 = 500 + 5100 = 5600$$

Reversing the order, for a full scale of 5600:

$$\text{Choice No.} = (5600 - 500) \quad 100 = 5100 \quad 100 = 51$$

Observing this series it will be noted that:

1. Full scale  $G_m$  values begin at 500.
2. Full scale  $G_m$  values progress in 100 micromhos steps.
3. There are 256 full scale values of  $G_m$  available.
4. The maximum full scale  $G_m$  value is 26,000.

An alternate system for determining the meter shunt resistors for desired full scale values of micromhos may be employed.

With no meter shunt and with L-12 closed the full scale value is 500.

Each meter shunt resistor then adds the following to the initial 500 micromhos.

Added Full Scale Micromhos	Meter Shunt Resistor	Switch Closed with L-12
100	A (1280 $\Omega$ )	C-12
200	B (640 $\Omega$ )	D-12
400	C (320 $\Omega$ )	E-12
800	D (160 $\Omega$ )	F-12
1600	E (80 $\Omega$ )	G-12
3200	F (40 $\Omega$ )	H-12
6400	G (20 $\Omega$ )	J-12
12,800	H (10 $\Omega$ )	K-12

The meter shunt resistors can be determined by subtracting 500 from the desired full scale value and from this remainder by subtracting the highest possible added full scale values.

For example, 9300 micromhos full scale is desired. Subtract 500 which leaves 8800. From the table, 6400 (Resistor "G" - 20 $\Omega$ ) is subtracted next which leaves 2400. Subtract 1600 (Resistor "E" - 80 $\Omega$ ) which leaves 800 (Resistor "D" - 160 $\Omega$ ). Therefore, resistors D, E, G will provide a 9300 micromho full scale range.

5.56 Extended Ranges of Full Scale Meter Micromhos. With switch L-12 closed and with all the meter shunt resistors used, the maximum full scale value is 26,000 micromhos. By leaving L-12 open and by closing L-7 the basic metering is extended and by repeating the same shunts across the extended meter a new set of micromho ranges is obtained. Although this set of ranges also begins at 500 micromhos its usefulness begins at 26,000 micromhos and it is recommended that full scale values from 26,000 to 128,000 micromhos only be used. For 500 to 26,000 micromhos the extended  $G_m$  ranges may inherently introduce plate circuit resistances which will result in readings deviating appreciably from the theoretical.

With switch L-7 closed, use the "Choice No." system with the same meter shunt identification with the following:

$$G_m = 500 (1 + \text{Choice No.}) \text{ and}$$

$$\text{Choice No.} = G_m \div 500 \text{ less } 1$$

Examples:

Choice No. 84 represents shunt resistors C, E and G (switches E-12, G-12 and J-12).