

Full Scale Gm = $500 (1 + 84) = 500 \times 85 = 42,500$.

Desired: 80,000 micromhos full scale.

Choice No. = $80,000 \div 500$ less 1 = $160 - 1 = 159$.

Choice No. 159 represents shunt resistors A, B, C, D, E and H or switches C, D, E, F, G, K-12 closed with L-7 closed and L-12 open.

5.57 Negative Grid Bias Voltages. The grid bias voltages are obtained according to the formula: $E_c = 150R \div (R + 15,000)$.

The following switches must be closed to apply a negative voltage from cathode (row 4) to grid (row 3):

H-14	K-13 (without 0.222 V signal)
L-14	L-13 (with 0.222 V signal)
A-16	Never close both K-13 and L-13.
C-16	

Select resistance "R" according to the above formula by leaving one or more of the following switches open:

10Ω:	D-13	100Ω:	E-13	1000Ω:	F-13	10,000Ω:	G-13
20Ω:	D-14	200Ω:	E-14	2000Ω:	F-14	20,000Ω:	G-14
30Ω:	D-15	300Ω:	E-15	3000Ω:	F-15	30,000Ω:	G-15
40Ω:	D-16	400Ω:	E-16	4000Ω:	F-16		

5.58 Self-bias Tests. If a triode or pentode is desired to be tested under self-bias the grid-cathode circuit must be arranged according to the following:

Close H-14, K-14, A-16, C-15, K-13 (L-13 if the signal is desired instead of K-13) and all except the resistance desired of the following:

10Ω:	D-13	100Ω:	E-13	1000Ω:	F-13	10,000Ω:	G-13
20Ω:	D-14	200Ω:	E-14	2000Ω:	F-14	20,000Ω:	G-14
30Ω:	D-15	300Ω:	E-15	3000Ω:	F-15	30,000Ω:	G-15
40Ω:	D-16	400Ω:	E-16	4000Ω:	F-16		

Note that a resistance may be made up of several combinations of these series resistors. A resistance of 50 ohms may consist of 10 and 40 or 20 and 30. A resistance of 1000 ohms may consist of 1000 ohms; 100, 200, 300, 400; or 10, 20, 30, 40, 200, 300 and 400. These decade resistors are within 1% of their indicated value. Also, 200 milliamperes may be passed through any resistor from 10 ohms up to and including the 1000 ohm resistor which is across F-13. The remaining individual resistors should never have in excess of 200 volts across them.

5.59 Plate Circuit Arrangement for Plate Current Measurements. In the event that a plate current test is desired using the regulated B+ source close J-15, K-15, A-13, C-13, J-17 and the suitable meter shunts C, D, E, F, G, H, J, K, L-12 and/or L-7. For pentodes the screen and plate voltage are the same for this circuit.

5.60 Meter Current Ranges. Since 50 on the 0-100 scale is the rejection point for most tubes, a convenient mathematical relationship was made to exist at half-scale for the current ranges. This tester has three sets of overlapping DC current ranges. With reference to the lettered resistors used for meter shunting in the "Choice Number" system for mutual conductance ranges the following formulas are useful in setting desired meter ranges.

Full Scale Milliamperes	(L-7 and L-12 Open) Close	Full Scale Milliamperes	(L-7 and L-12 Open) Close
30	C, D, E, F-12	200	E, H, J-12
50	C, F, G-12	300	D, E, G, K-12
100	D, G, H-12	500	D, F, G, H, J, K-12

5.61 Miscellaneous Switches. For filamentary tubes switch L-11 places a 100 ohm center-tapped resistor across the filament to reach the electrical center. One end of this resistor is permanently connected to row 2 or the filament minus (-) supply and the center-tap becomes connected to the cathode supply after the quality button (No. 2 button) is depressed. Do not close L-11 when the filament or heater voltage is greater than 12.6 volts.

Switch G-17 is closed for filamentary amplifier tubes to prevent a meter deflection for normal tubes on the heater-cathode leakage test.

For all filamentary tube types close switches A-12, B-14 and C-14. If these switches are open and a plate or screen to filament short is present the meter will deflect to the left with appreciable force although no damage will be done. Since this deflection is not intended to identify the short, the meter sensitivity may be reduced by using the three heater-cathode leakage parallel resistors across the meter.

D. Diode and Rectifier Tube Test Circuit Programming

5.62 The filaments and heaters of diodes and rectifiers should be treated the same as those for amplifier tubes. For filamentary types it will be sufficient to close L-11 only and it will not be necessary to close the switch in row 4 that corresponds to the switch closed in row 2. Also, it will not be necessary to close G-17 for diodes and rectifiers.

5.63 Heater - Cathode Leakage Consideration for Diodes and Rectifiers. For detector-type diodes wherein signals to be amplified are involved, a lower value of rejection may be set. A value of 20 microamperes is generally satisfactory. For power rectifiers a higher level of leakage is acceptable and 150 microamperes is suitable for most tubes such as the 6X4. Damper diodes used in horizontal deflection circuits for cathode ray tubes are made to withstand higher heater-cathode voltages than other types of rectifiers. Therefore a lower level of leakage is an inherent feature of this tube. Rejection at 10 microamperes is desired for damper diodes. For filamentary diodes or rectifiers use switches A-14, B-14, and C-14 for the reason stated in paragraph 5.61, Miscellaneous Switches.

5.64 Plate-Cathode Circuit Configurations.

- a. The simplest of diode test circuits is one wherein the diode is treated as a triode without the grid-cathode circuit consideration. With L-14 closed and the rest of the plate circuit arranged per paragraph 5.58 a plate current test is readily provided. For DC currents up to 30 milliamperes the manually controlled Auxiliary B+ supply may be used by opening J-15 (and K-5) and by closing L-5. The 0-100 scale indication X3 will be the applied DC voltage when monitored by depressing the Aux. B+ button in the Auxiliary Control Compartment. If current limiting resistance is desired in the plate-cathode circuit open L-14, close H-14, A-16, C-15 and open the switches across the desired decade resistors described in paragraph 5.57. Because of the current delivering capability of the regulated DC supplies, the meter ranges available and the resistances attainable the described circuit is suitable for plate current tests on high voltage diodes and high and low perveance diodes.
- b. Half-wave power rectifiers intended for use with a 117 VAC line may be tested in a circuit that subjects the tube to its rated inverse voltage at the same time

6. MAINTENANCE

A. General

6.01 Most maintenance on this equipment can be accomplished with the aid of the Routine Calibration procedure, the Complete Calibration Procedure, the Trouble Shooting Procedure and the Voltage and Resistance Chart. All these procedures make use of test cards stored in the tester case cover.

B. Complete Calibration

6.02 Perform the Routine Calibration procedure as listed in section 3. Then proceed as follows:

6.03 Signal Adjustments:

- a. Connect the tube tester to the power line thru a Variac set to 115 volts. See figure 13. Turn the instrument on.

Insert Card 11, SIG. REG. AND AMPL, into the Card Switch. Connect a high-impedance, sensitive AC voltmeter from pin 3 to pin 6 on any convenient socket. NOTE: THIS MUST BE A HIGH IMPEDANCE AC VACUUM TUBE VOLTMETER, CAPABLE OF ACCURATE MEASUREMENT OF 0.222 VOLTS RMS. BALL ANTINE MODEL 300 OR EQUIVALENT IS RECOMMENDED.

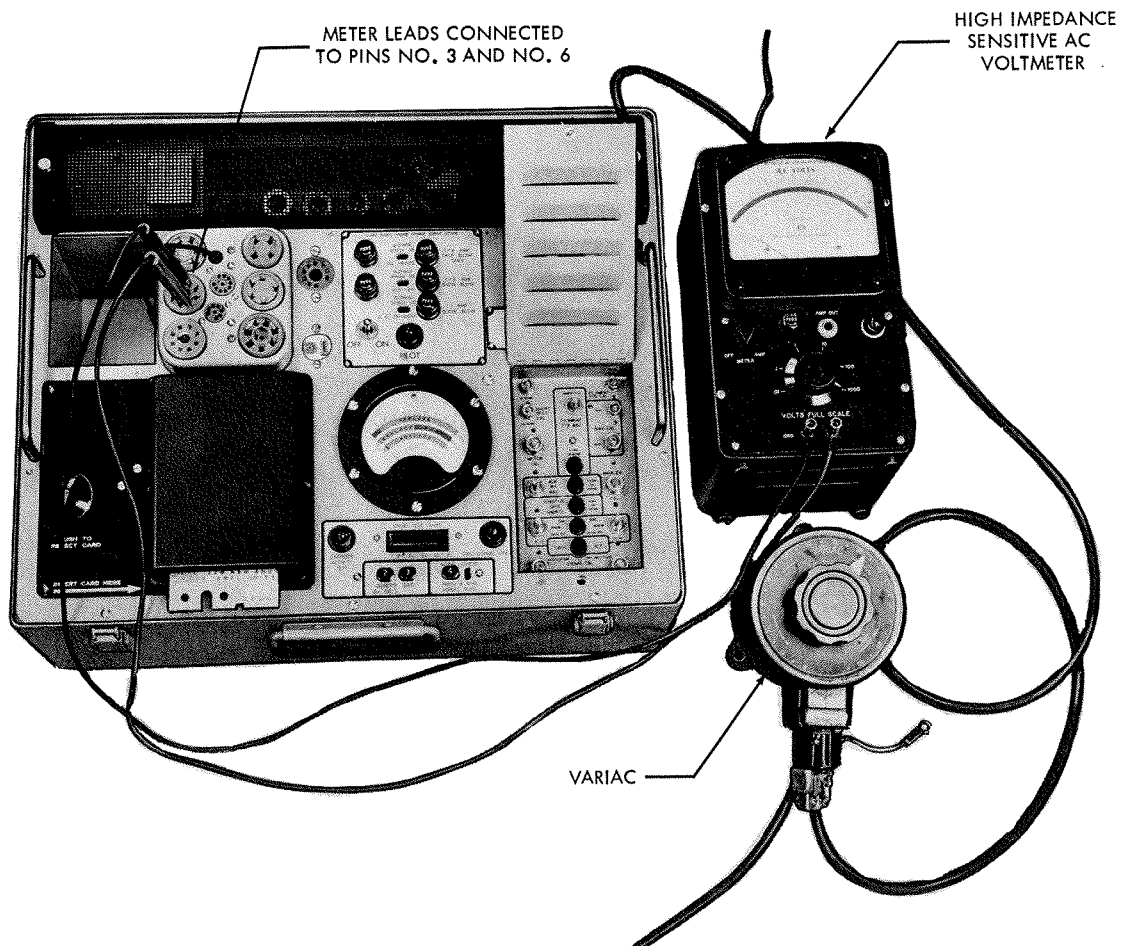

Figure 13 - Signal Regulation and Amplitude Check

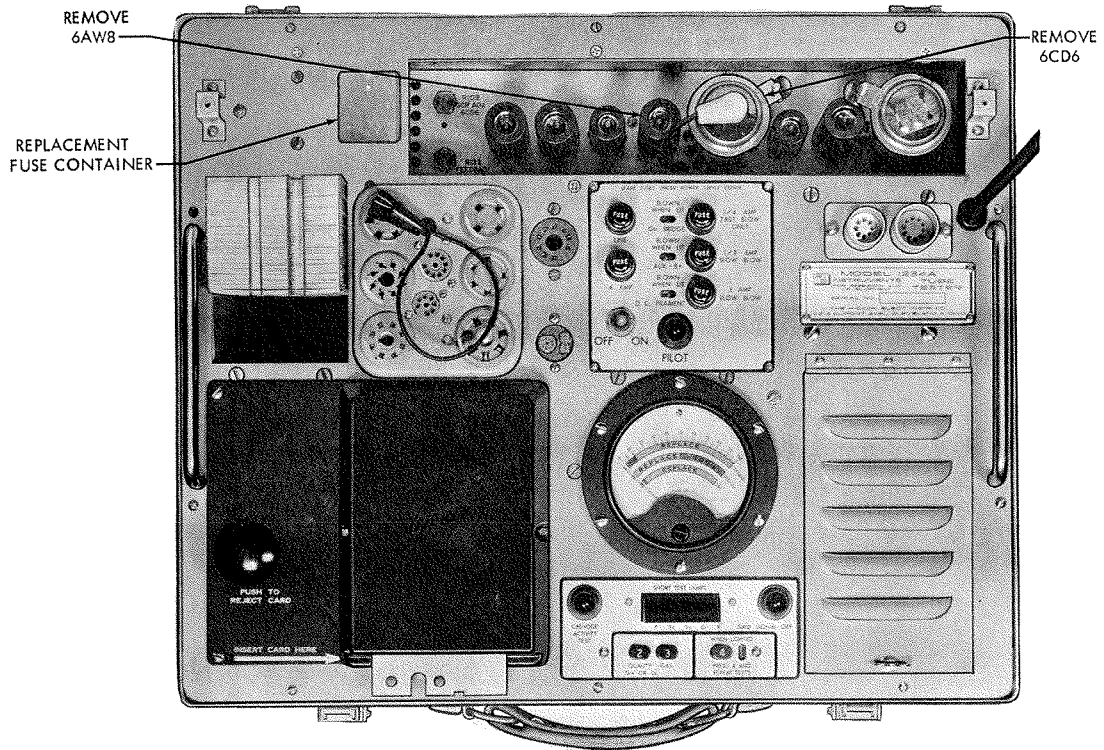

Figure 14 - B+ Power Supply Feed Back Current Test

Press button #2. The meter should read mid-scale (1MA feedback current.) If reading is not correct, adjust the FEEDBACK CURRENT ADJ. control, R123, located on the power supply chassis, for proper indication.

After proper adjustment - REMOVE CARD 13 FROM THE CARD SWITCH BEFORE RETURNING THE 6CD6 AND 6AW8A TO THEIR PROPER SOCKETS.

Insert Card #8, MAIN B PLUS CAL. Press button #2 and check for a mid-scale reading. Readjust the MAIN B+ CAL control if necessary.

b. Series Regulator Screen Voltage Adjustment.

Insert Card 14A, 6CD6, SCR. ADJUST. Press button #2. The meter reading should be approximately mid-scale. While holding down button #2, slowly rotate the SCR. ADJ. control, R109 (located on the power supply chassis) counter-clockwise until the meter indication just starts to drop from its normal mid-scale position. Then turn the control clockwise just enough to restore the mid-scale reading and leave it at this setting.

C. Trouble Shooting Procedure

6.06 General

As stated earlier the Model 1234A is equipped with self-calibrating features. The calibration program cards also greatly simplify the troubleshooting of the tester. The

of this network for proper characteristics, and check the power transformer T101 between taps 18 and 19 for 10 volts RMS.

6. 10 Signal Regulation

The signal bridge adjustments are set using card 11 as instructed in Section 6. 03. If proper adjustment cannot be made, check the components of the signal bridge circuit, including resistors R153, R154 and R156, potentiometers R152 and R155 and the #47 lamps DS109 and DS110. Also check the power transformer T101 for the proper voltage (10 volts RMS) between taps 20 and 21.

6. 11 Main B+ Power Supply Tracking.

Insert Cards 15 thru 22 successively into the card switch. Push button #2. The meter should indicate mid-scale ± 2 divisions in each case.

During these tests an accurate DC voltmeter (20, 000 ohms per volt, Hickok Model 456, or equivalent) may be connected to pins 3 and 6 on any convenient socket as shown in Figure 15. The voltage readings on the external meter should be as follows:

<u>Card #</u>	<u>Indicated Voltage</u>	<u>Component</u>	
15	10	R238	10K $\pm 1\%$
16	20	R239	20K $\pm 1\%$
17	20	R240	20K $\pm 1\%$
18	60	R237	62K $\pm 1\%$
19	110	R236	52K $\pm 1\%$
20	160	R235	52K $\pm 1\%$
21	210	R234	52K $\pm 1\%$
22	260		

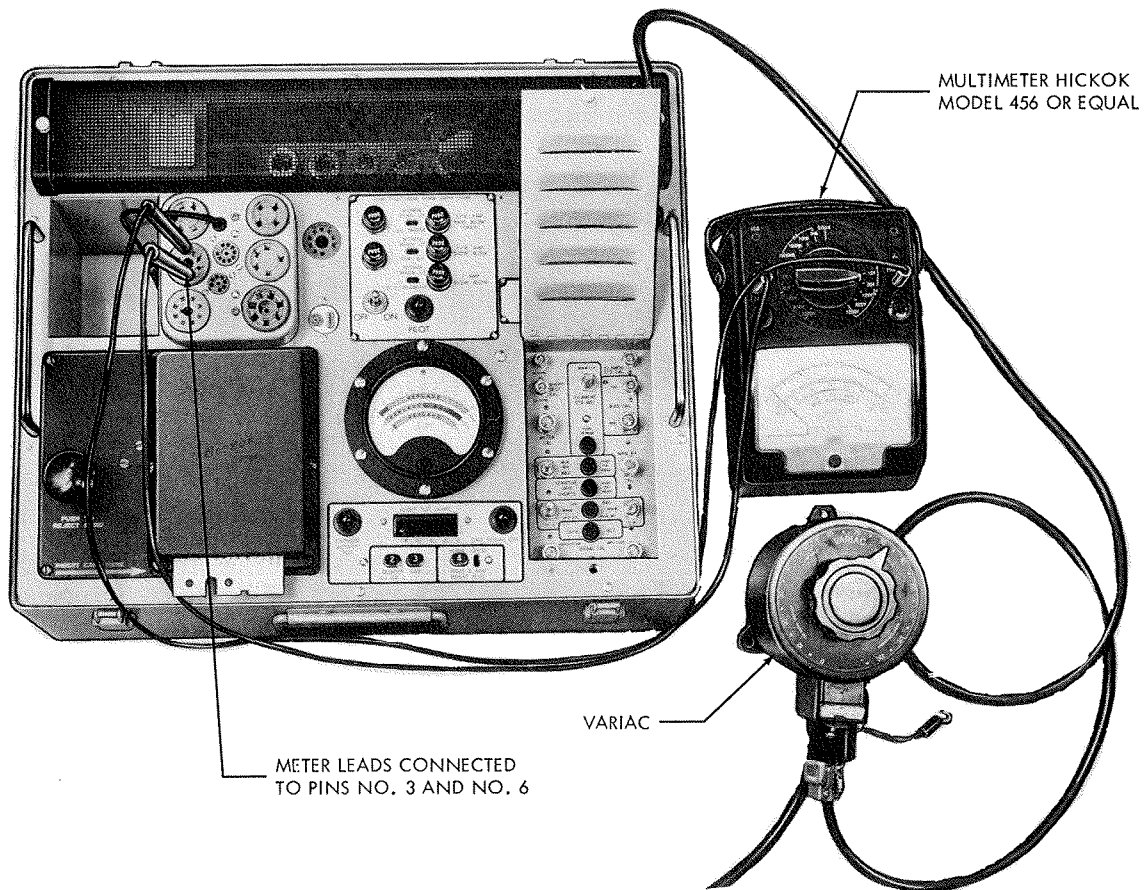

Figure 15 - Checking Main B+ Power Supply With the Aid of an External Meter

permits the tester meter (set at 300 volts F. S.) to monitor the voltage output of the AUX B+ Supply. Rotate the associated control knob in the auxiliary control panel thru its complete range. The tester meter indication should vary from approximately 10 on the scale to at least full scale. (Some overswing is permissible at both ends of the control adjustment).

Voltmeter Circuit: While still pressing the AUX B+ ADJ. button set the control to give a mid-scale reading on the meter. Release the AUX B+ ADJ. button and press button #2. The meter should read mid-scale ± 2 division. This is a check of the auxiliary B+ supply metering circuit which is separate from the main metering circuits. If the reading is out of tolerance, check R-320, 3 megohm $\pm 1\%$.

Line Regulation: While holding down button #2 vary the line voltage from 115 to 125 then to 105. The meter readings at 105 and 125 volts should not vary more than ± 3 divisions from the reading at 115 volts line.

Load Regulation: Set line voltage at 105 volts. Push button #2. Note the reading on the meter (it should still be at mid-scale, from the previous steps). This is a 150 volt indication at a low output current. While holding button #2, press button #4. The meter will indicate the output voltage with rated output current being drawn from the supply. The deviation between the two readings should not exceed ± 3 divisions.

If indications during the above tests are not proper, check V106, 6203, V104, 6CL6; and V107B, 6AU8 pentode section. Also check voltage and resistances at tube sockets against values listed in the voltage and resistance chart.

If desired a 20,000 ohms per volt meter (Hickok Model 456 or equivalent) may be connected from pin 3 (+) to pin 6 (-) on any convenient socket to externally monitor the same output voltage being measured on the tester meter.

Insert proper card into card switch, the left three short lamps should light. Press the FILAMENT STD ADJ. push button and set FILAMENT STD. ADJ switch for mid-scale indication on the tester meter. Press button #2, meter should read mid-scale ± 2 divisions.

<u>Card No.</u>	<u>Primary Component</u>	<u>Secondary Component</u>
37	R218, 10 $\Omega \pm 1\%$	R206, R210, R213, R214
38	R217, 20 $\Omega \pm 1\%$	Same as card 35
39	R216, 30 $\Omega \pm 1\%$	Same as card 35
40	R215, 40 $\Omega \pm 1\%$	Same as card 35

b. Procedure for test cards 41 and 42:

Insert proper test card into card switch. The left three short lamps should light. Press the FILAMENT STD ADJ push button and set FILAMENT STD ADJ switch for mid-scale indication on the tester meter. Press button #2. The tester meter should indicate mid-scale ± 2 divisions.

<u>Card No.</u>	<u>Primary Component</u>	<u>Secondary Component</u>
41	R219, 100 $\Omega \pm 1\%$	R206, R210, R213, R214
42	R220, 200 $\Omega \pm 1\%$	R206, R210, R213, R214

c. Procedure for test cards 43 through 48:

Insert proper test card. The extreme left short lamp should light. Press button #2. Read mid-scale ± 2 divisions.

<u>Card No.</u>	<u>Primary Component</u>	<u>Secondary Component</u>
43	R221, 300 $\Omega \pm 1\%$	R206, R208, R209, R210 R211, R212
44	R222, 400 $\Omega \pm 1\%$	R206, R207, R208, R209, R210, R212
45	R226, 1000 $\Omega \pm 1\%$	R206, R207, R208, R211
46	R225, 2000 $\Omega \pm 1\%$	R206, R207, R208, R209, R213, R214
47	R224, 3000 $\Omega \pm 1\%$	R206, R209, R214, R241
48	R223, 4000 $\Omega \pm 1\%$	R206, R207, R208, R212, R213, R241

d. Procedure for test Cards 49 thru 51 is the same as above except tolerance is mid-scale ± 4 divisions.

<u>Card No.</u>	<u>Primary Component</u>	<u>Secondary Components</u>
49	R227 & R231 in parallel 10K $\pm 5\%$	R207, R208, R213, R214
50	R228, 20K $\pm 5\%$	R207, R208, R209, R210, R211, R213
51	R229, 30K $\pm 5\%$	R208, R209, R210, R211, R212

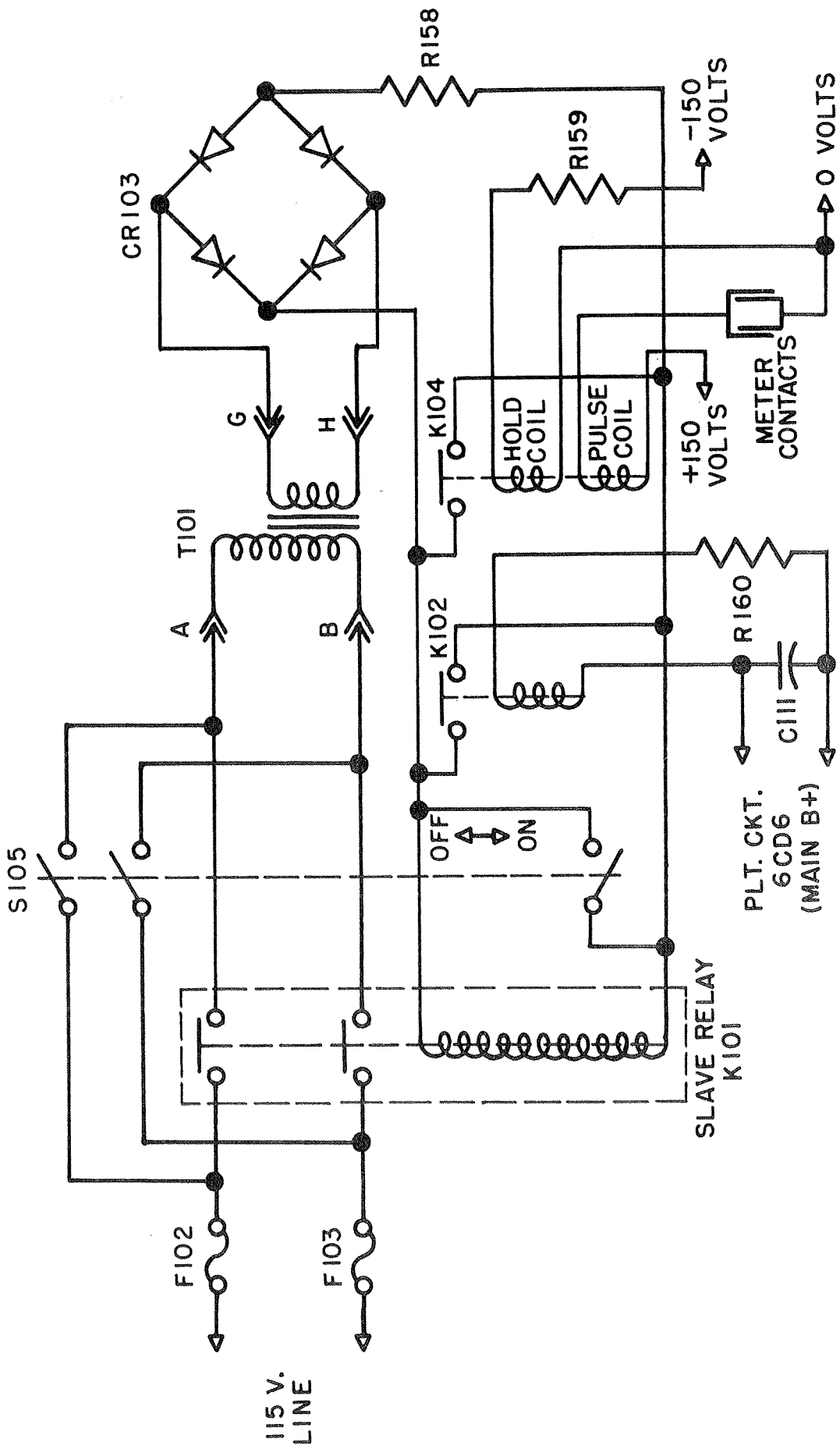

Figure 16 - Slave Relay Protective Circuit

plate holes when the micro switch actuates (an audible CLICK will be heard). If adjustment is necessary, turn the adjustment screw. (See figure 19) until alignment is correct.

3. Connect the tester to power source and press ON switch. Retest the action of the switch with the code card. Replace the card switch cover.

6.20 Adjustment of Contact Pins

If code card will not come out of card switch when reject knob is pressed, a contact pin has moved above its normal position and is projecting through a hole in code card. Correct as follows:

- a. Disconnect power source line cord. Remove switch cover.
- b. Inspect tops of contact pins to see if one or more has moved above normal position. Use probe and carefully push pin or pins down until they clear code card.
- c. Connect power source line cord and press ON switch. Reactivate card switch several times with same code card. Card must slide out each time reject knob is pressed.

E. Miscellaneous Parts Replacement

6.21 Replacement of Parts. The replacement instructions contained herein are limited to high mortality parts which are in some way unusual in installation. When trouble shooting procedures reveal defective parts and replacement is necessary, every effort must be made to duplicate original condition of equipment. Recalibrate tube tester after replacement of parts to assure accuracy of tube test readings.

6.22 Replacement of Tubes. Exercise care when removing or installing electron tubes to assure high quality performance from associated circuits. Observe handling precautions which are common to all vacuum tubes.

6.23 Replacement of Diodes. The diodes (CR401, CR402, CR403 and CR404 (Schematic Sheet 2), mounted on the terminal board are either matched pairs or all four are matched together and must be replaced as matched units. They shall be physically mounted in the same manner as those which are removed. Note direction of arrow printed on diodes and position replacement part in identical relationship to terminals.

C A U T I O N

Do not overheat diodes during soldering operation. Hold lead wire with pliers positioned between diode body and point being soldered.

6.24 Replacement of Upper Micro-Switch. (See figure 18). Unsolder leads from terminals on micro-switch. Remove nuts, washers and screws securing micro-switch to bracket. Remove microswitch. Exercise care not to lose small actuating pin in card switch. Install new micro-switch in reverse order of removal procedure.

6.25 Replacement of Lower Micro Switch. Remove screws and spacers securing terminal board to card switch. Lift terminal board away from card switch to gain access to lower micro switch. Unsolder leads to micro switch terminals. Remove nuts, washers, screws and defective micro switch. Position new micro switch in place and install it in reverse order of removal procedure. Check to see that switch actuating screw engages micro switch as required when card-reject knob is pressed. If adjustment is required, loosen lock nut, make adjustment, and retighten lock nut.

POWER SUPPLY MODEL 1234A

Note 1. Insert test card #23 in card switch. Press the AUX B+ ADJ Button and adjust the AUX B+ Supply for mid-scale meter reading.

Note 2. All voltages measured with VTVM. Zero voltage reference point is Pin 1 of OA2 socket.

TUBE	SOCKET PIN NO.								
	1	2	3	4	5	6	7	8	9
6AU8 <i>107</i>	0 (0Ω)	-2 (3MΩ)	150.0 (70KΩ)	3.1 AC (0Ω)	3.1 AC (0Ω)	-86.0 (40KΩ)	-87.0 (160KΩ)	-28.0 (115KΩ)	97.0 (10MΩ)
6CL6 <i>104</i>	150.0 (650KΩ)	100.0 (10MΩ)	405.0 (95KΩ)	150.0 (650KΩ)	150.0 (650KΩ)	405.0 (95KΩ)	150.0 (650KΩ)	NC	NC
OA2WA <i>105</i>	0 (0Ω)	NC	NC	-150.0 (34KΩ)	NC	NC	-150.0 (34KΩ)	--	--
6AW8 A <i>105</i>	-99 (50KΩ)	-100 (63KΩ)	0 (0Ω)	3.1 AC (0Ω)	3.1 AC (0Ω)	-100.0 (60KΩ)	-100.0 (70KΩ)	-55.0 (60KΩ)	121.0 (600KΩ)
6CD6 <i>103</i>	NC	156.0 (80KΩ)	150.0 (80KΩ)	NC	121.0 (580KΩ)	NC	150.0 (80KΩ)	275.0 (Infinity Ω)	--
6C4WA <i>102</i>	400.0 (95KΩ)	NC	150.0 (80KΩ)	150.0 (80KΩ)	400.0 (95KΩ)	260.0 (350KΩ)	275.0 (Infinity Ω)	--	--
6203 <i>106</i>	305.0 AC (73Ω)	NC	150.0 (660KΩ)	150.0 (660KΩ)	NC	--	406.0 (100KΩ)	--	305.0 AC (73Ω)
5U4 GB <i>101</i>	NC	370.0 (510KΩ)	NC	260.0 AC (67Ω)	NC	260.0 AC (67Ω)	NC	370.0 (510KΩ)	--

Figure 20 Voltage and Resistance Data