

RECOMMENDED  
INSTALLATION  
TOOLING

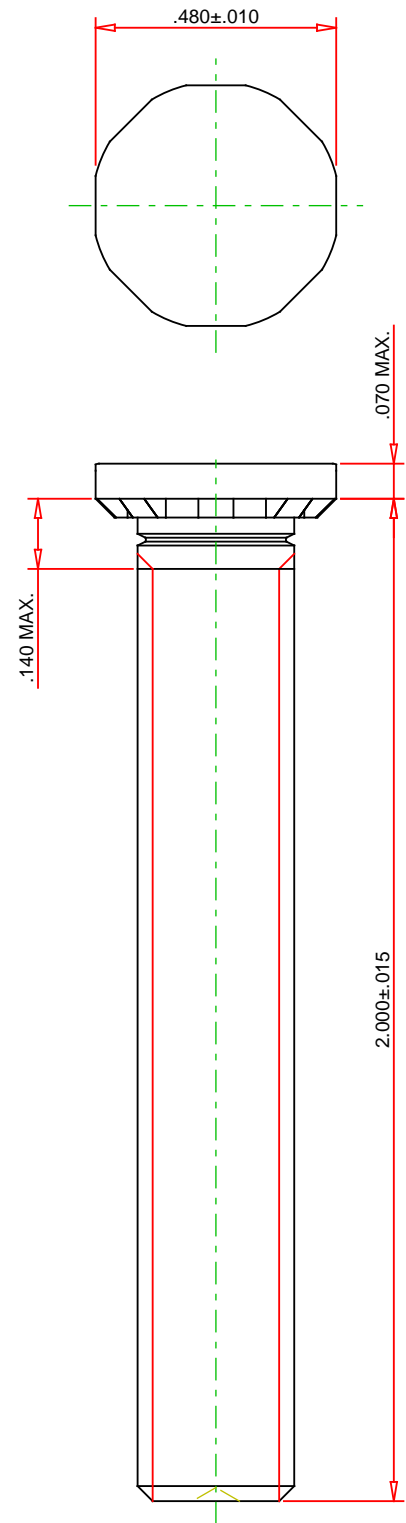
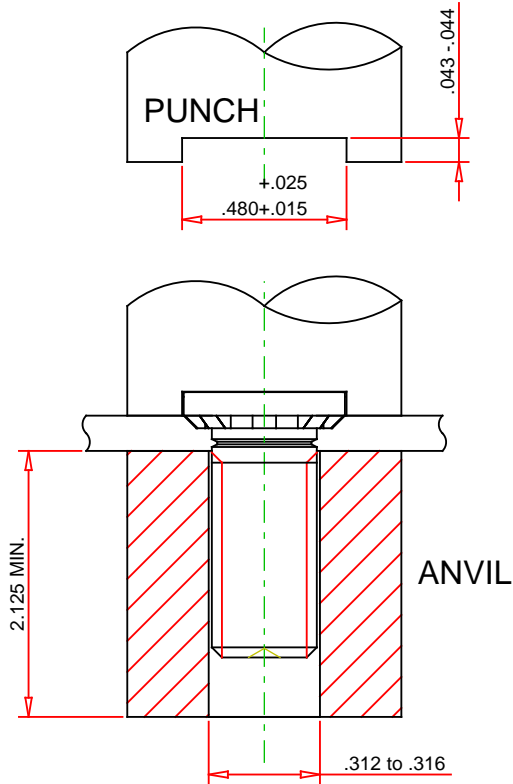

© 2021 PennEngineering

ALL DIMENSIONS IN INCHES

DATE 28-JUN-2021

NOTE : DRAWING NOT TO SCALE

THREAD :	.313-18 (5/16-18)	MOUNTING HOLE DIA. :	.312 +.005 -.000
MATERIAL:	PHOSPHOR BRONZE	PANEL THICKNESS:	.075 MINIMUM
HEAT TREAT:	NONE	MAX. PANEL HARDNESS:	HRB 55 / HB 83
FINISH:	NO FINISH	MIN CENTERLINE-TO-EDGE:	0.5

DESCRIPTION :  
HIGH-STRENGTH STUDS - TYPE HFH/HFHS/HFHB -  
UNIFIED

PART NO. :  
HFHB-0518-32X



PennEngineering®

EMAIL: TECHSUPPORT@PEMNET.COM  
WWW.PEMNET.COM