

RECOMMENDED
INSTALLATION
TOOLING

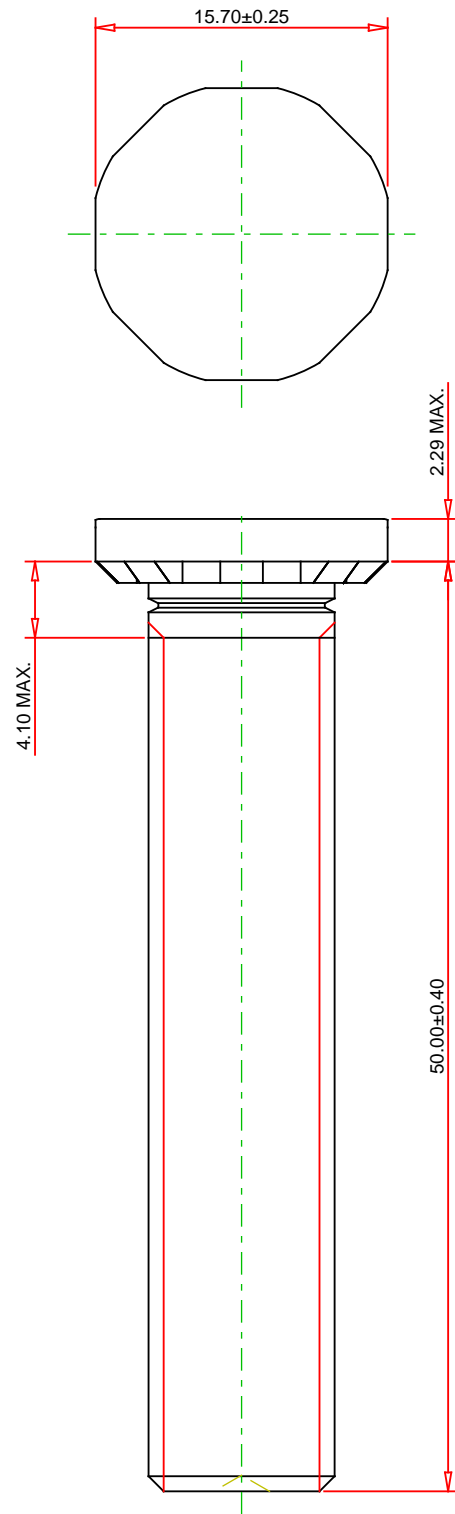
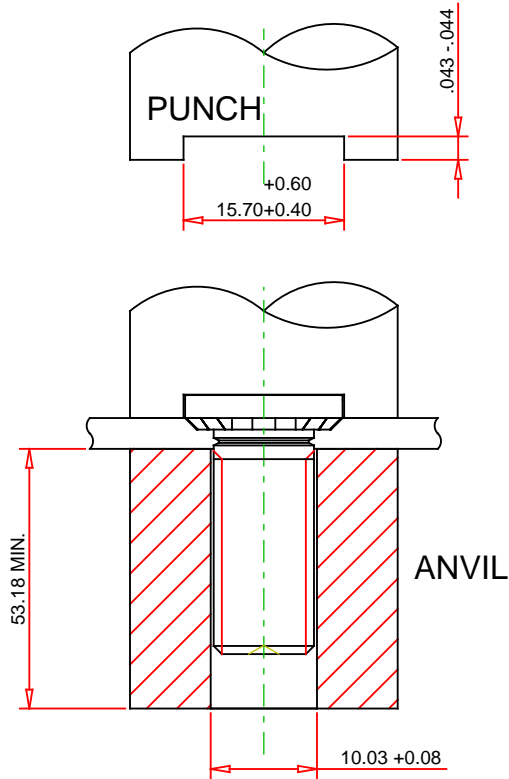

© 2021 PennEngineering

ALL DIMENSIONS IN MILLIMETERS

DATE 28-JUN-2021

NOTE : DRAWING NOT TO SCALE

THREAD :	M10 x 1.5	MOUNTING HOLE DIA. :	10.00 +0.13 -0.00
MATERIAL:	PHOSPHOR BRONZE	PANEL THICKNESS:	2.30 MINIMUM
HEAT TREAT:	NONE	MAX. PANEL HARDNESS:	HRB 55 / HB 83
FINISH:	NO FINISH	MIN CENTERLINE-TO-EDGE:	13.7

DESCRIPTION :
HIGH-STRENGTH STUDS - TYPE HFH/HFHS/HFHB -
METRIC

PART NO. :
HFHB-M10-50X



PennEngineering®

EMAIL: TECHSUPPORT@PEMNET.COM
WWW.PEMNET.COM