

RECOMMENDED  
INSTALLATION  
TOOLING

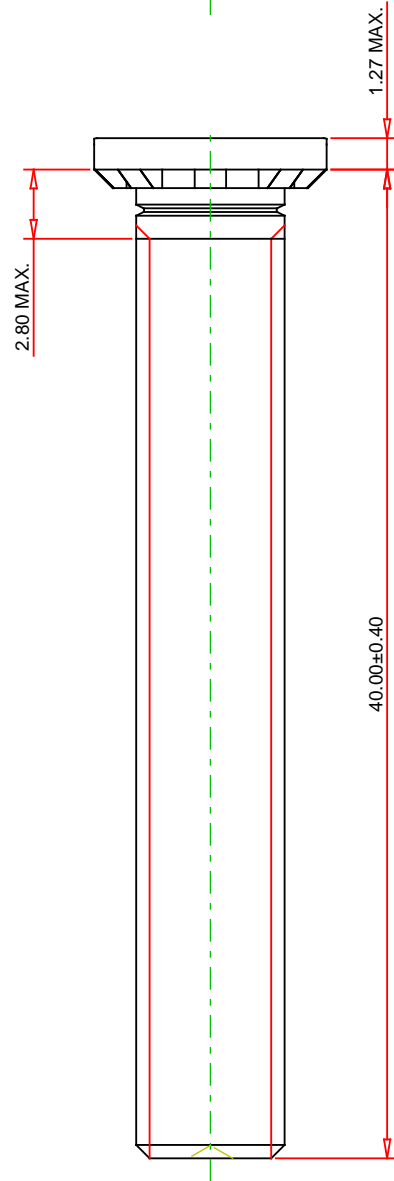
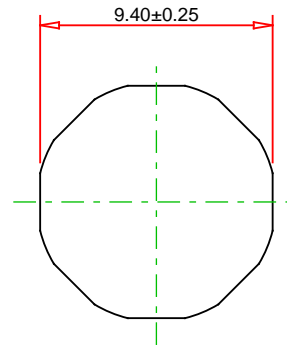
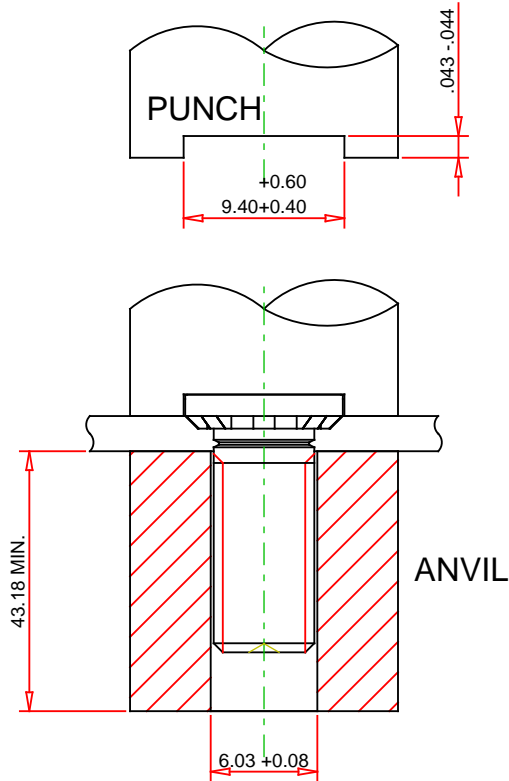

© 2021 PennEngineering

ALL DIMENSIONS IN MILLIMETERS

DATE 28-JUN-2021

NOTE : DRAWING NOT TO SCALE

THREAD : M6 x 1	MOUNTING HOLE DIA. : 6.00 +0.13 -0.00
MATERIAL: PHOSPHOR BRONZE	PANEL THICKNESS: 1.50 MINIMUM
HEAT TREAT: NONE	MAX. PANEL HARDNESS: HRB 55 / HB 83
FINISH: NO FINISH	MIN CENTERLINE-TO-EDGE: 11.5

DESCRIPTION :  
HIGH-STRENGTH STUDS - TYPE HFH/HFHS/HFHB -  
METRIC



PennEngineering®

PART NO. :  
HFHB-M6-40X

EMAIL: TECHSUPPORT@PEMNET.COM  
WWW.PEMNET.COM