

Drill 3.7dia  
and Tap M4x0.7  
10mm deep

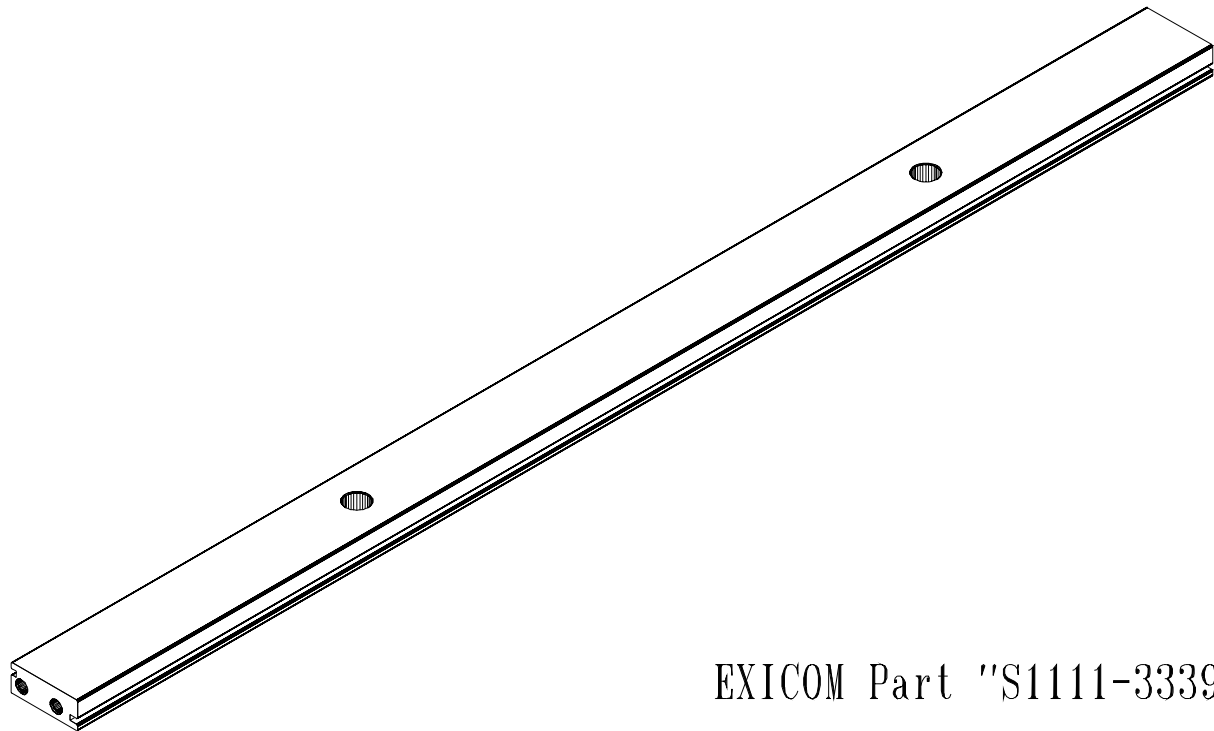

EXICOM Part "S1111-33393"

MATERIAL  
Extrusion  
No.2565

ALLOY  
6063-T5

EST. AREA  
265 mm

EST. WEIGHT  
2.80 kg/m

EST. PERIPHERY  
EXT: 354 mm  
TOT: 354 mm

TOLERANCE  
0-00mm ±0.1mm  
00-0mm ±0.25mm  
0000mm ±0.5mm  
0-600mm ±0.1mm  
> 600mm ±0.5mm

BS1474:1987  
APPLIES UNLESS  
OTHERWISE  
SPECIFIED

JOB No.  
3037

**CASA** Modular Systems

P.O. BOX 38-828, WELLINGTON, NEW ZEALAND  
TELEPHONE : (64-4) 5687 277  
FACSIMILE : (64-4) 5685 161

CUSTOMER : EXICOM Technologies

DESCRIPTION : BAR Corner 25mm x 10mm

DRAWN : A.W.D DATE : 05/05/97 APPROVED : ? DWG. SCALE : 1:1

SIZE A4 DRAWING Reference No. EXI-2565 ISSUE A

© COPYRIGHT : CASA Modular Systems ALL RIGHTS RESERVED