

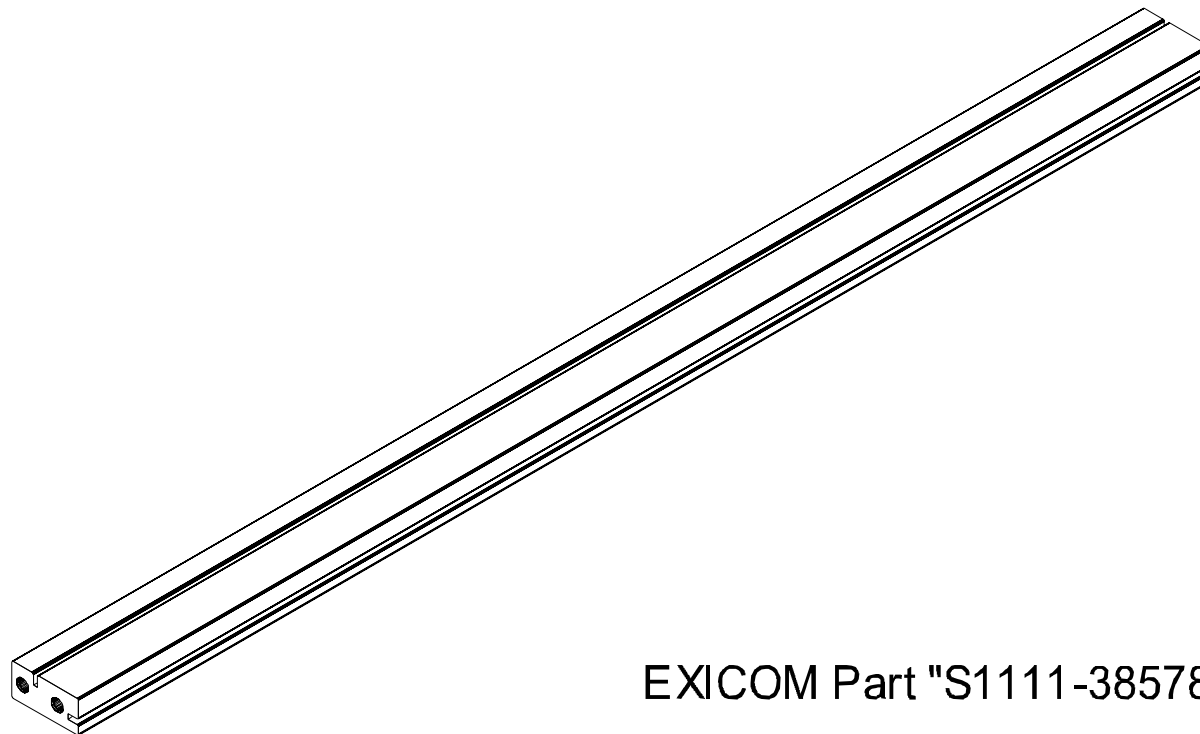

Drill 3.7dia
and Tap M4x0.7
10mm deep



EXICOM Part "S1111-38578"

MATERIAL Extrusion No.2567
ALLOY 6063-T5
EST. AREA 265 mm
EST. WEIGHT 2.80 kg/m
EST. PERIPHERY EXT: 354 mm TOT: 354 mm
TOLERANCE 0-00mm ±0.1mm 00-0mm ±0.25mm 0000mm ±0.5mm 0-600mm ±0.1mm > 600mm ±0.5mm
BS1474:1987 APPLIES UNLESS OTHERWISE SPECIFIED
JOB No. 3037

 Modular Systems P.O. BOX 38-828, WELLINGTON, NEW ZEALAND TELEPHONE : (64-4) 5687 277 FACSIMILE : (64-4) 5685 161	CUSTOMER : EXICOM Technologies		SIZE A4	DRAWING Reference No. EXI-2583	ISSUE A
	DESCRIPTION : BAR Corner 25mm x 12mm				
DRAWN : AWD	DATE : 10/04/01	APPROVED : ?	DWG. SCALE : 1:1	© COPYRIGHT : CASA Modular Systems ALL RIGHTS RESERVED	