

APPLICATIONS: EIA rack-mount chassis, tool boxes, industrial work stations, data processing, mechanical devices, point-of-purchase displays, and medical applications. Use model 201 whenever a light duty, 3/4 extension slide with positive stop is required.

Low Profile, Light Duty Slide
3/4 Extension
Up to 108 lb. [49 kg.] Capacity*

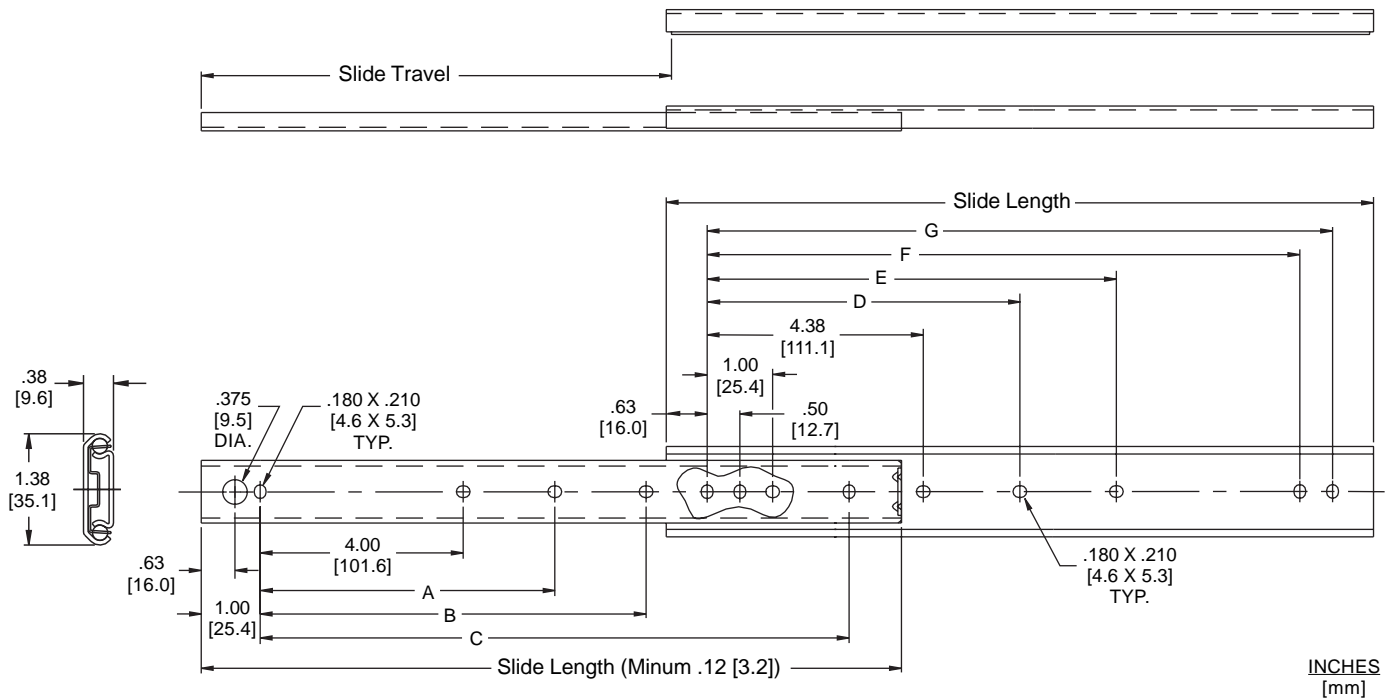

Finish Bright electro-zinc (C)

Length 12" to 28" [305mm to 711mm]

Travel 3/4" length of slide

Height 1.38" [35.1]

Load See chart *

Sidespace .38" + .030 / - .000
[9.6mm + 0.76 / - 0.00]

Mounting Side, bracket or hard mounting

Hardware #8 pan head screws

Features Positive stop

* Load rating based on slides mounted in a 16" wide drawer cycled 10,000 times.

Part Number	Slide Length	Slide Travel	Load Rating lbs [kg] per pair *	A	B	C	D	E	F	G
201-12	12.00 [305]	9.00 [229]	108 [49]		6.00 [152.4]	10.00 [254.0]		5.87 [149.1]	10.25 [260.4]	10.75 [273.1]
201-14	14.00 [356]	11.00 [279]	103 [47]		8.00 [203.2]	12.00 [304.8]		7.87 [199.9]	12.25 [311.2]	12.75 [323.9]
201-16	16.00 [406]	12.00 [305]	95 [43]		10.00 [254.0]	14.00 [355.6]		9.87 [250.7]	14.25 [362.0]	14.75 [374.7]
201-18	18.00 [457]	13.00 [330]	90 [41]	8.00 [203.2]	12.00 [304.8]	16.00 [406.4]	8.37 [212.6]	11.87 [301.5]	16.25 [412.8]	16.75 [425.5]
201-20	20.00 [508]	15.00 [381]	82 [37]	9.00 [228.6]	14.00 [355.6]	18.00 [457.2]	9.37 [238.0]	13.87 [352.3]	18.25 [463.6]	18.75 [476.3]
201-22	22.00 [559]	16.00 [406]	75 [34]	10.00 [254.0]	16.00 [406.4]	20.00 [508.0]	10.37 [263.4]	15.87 [403.1]	20.25 [514.4]	20.75 [527.1]
201-24	24.00 [610]	17.00 [432]	67 [30]	11.00 [279.4]	18.00 [457.2]	22.00 [558.8]	11.37 [288.8]	17.87 [453.9]	22.25 [565.2]	22.75 [577.9]
201-26	26.00 [660]	19.00 [483]	60 [27]	12.00 [304.8]	20.00 [508.0]	24.00 [609.6]	12.37 [314.2]	19.87 [504.7]	24.25 [616.0]	24.75 [628.7]
201-28	28.00 [711]	20.00 [508]	55 [25]	13.00 [330.2]	22.00 [558.8]	26.00 [660.4]	13.37 [339.6]	21.87 [555.5]	26.25 [666.8]	26.75 [679.5]

Installation Instructions

Instructions to Bracket Mount

1. To ensure proper operation of the slides, make certain all mounting screws are inserted so the screw heads are inside the slides. (No washers on the inside of the slides.)
2. If sufficient space is available to install chassis from the rear of the rack, separate slide members (from the rear) for ease of installation. Otherwise, use access holes provided for mounting slide members to chassis and rack.
3. Using mounting kits and brackets, mount brackets to slide outer members (largest). For adjustment purposes screw the back brackets on loosely.
4. Install slides into EIA rack with #10-32 (customer supplied) screws and secure with bar nuts. Rear adjustment is possible by aligning the back bracket. Do not tighten screws until final adjustment is made.
5. Mount slide inner members (smallest) to the chassis. Position inner members 1/8" [3.2] from the front edge of the chassis making sure both slides are parallel.
6. Check slide alignment by opening and closing the chassis. Any sign of binding indicates lateral stress or misalignment.
7. Adjust slide position until movement is smooth. Tighten all screws and if necessary use more to secure slides and complete installation.

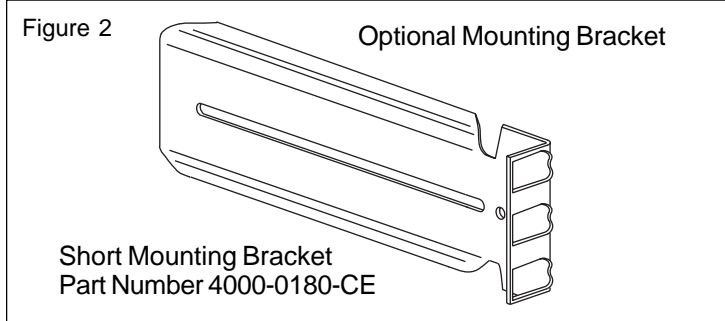
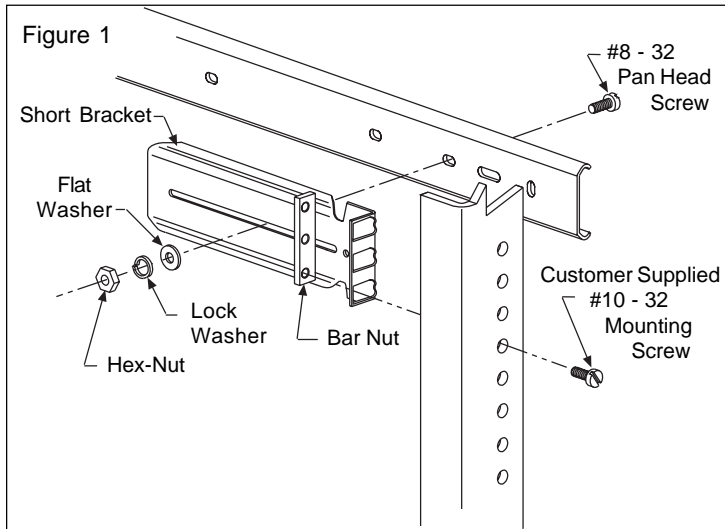

Instructions to Hard Mount

1. Follow steps 1 & 2 of "Bracket Mount" instructions.
2. Install slide outer members (largest) into cabinet using # 8 pan head screws. Be sure slides are parallel.
3. Mount slide inner members (smallest) onto chassis. Leave all screws loose for future adjustment. Make sure slides are parallel.
4. Follow steps 6 & 7 of "Bracket Mount" instructions.

Slide Ordering Instructions

Complete your slide order for Model 201 by specifying the following:

	<u>10 Pair</u>	<u>C</u>	<u>201</u>	<u>-18</u>	<u>D</u>
Total Slides Required	_____	_____	_____	_____	_____
Slide Finish	_____	_____	_____	_____	_____
Slide Model	_____	_____	_____	_____	_____
Slide Length	_____	_____	_____	_____	_____
Optional Polybag Packaging (includes mounting screws)	_____	_____	_____	_____	_____

Packaging

Distributor (D) Pack: All lengths are packaged 10 pair per box. Polybag includes one pair of slides and one screw hardware kit. Bracket kit ordered separately.

Bulk (P) Pack: Lengths 12" - 18" 25 pair per box
 Lengths 20" - 22" 20 pair per box
 Lengths 24" - 28" 10 pair per box

Order optional bracket mounting hardware kit (part number 4180-0222-XE) or bulk brackets and hardware kits separately.

Optional Hardware Kits

Optional mounting brackets are ordered as **kits** or **bulk**.

Each **kit** contains enough brackets and hardware to mount one pair of slides. Order kit part number 4180-0222-XE.

	<u>10 Each</u>	<u>4180-0222-XE</u>
Total Bracket Kits Required	_____	_____
Optional Bracket Kit Part Number	_____	_____

Bracket kit includes the following. See Figure 1.

4 short brackets (Part number 4000-0180-CE)
 1 bracket hardware kit* (Part number 4180-0230-XE)

(*Kit contains screws, hex-nuts, washers, bar nuts)

For **bulk**, order 4 each short brackets and 1 hardware kit per pair of slides required. See Figure 2.

	<u>20 Each</u>	<u>4000-0180-CE</u>
Total Brackets Required	_____	_____
Bracket Part Number	_____	_____

	<u>5 Each</u>	<u>4180-0230-XE</u>
Total Hardware Kits Required	_____	_____
Hardware Kit* Part Number	_____	_____

(*Kit contains screws, hex-nuts, washers, bar nuts.)

Specifications

Slide members: Cold rolled steel
 Ball retainers: Cold rolled steel
 Ball bearings: Carburized steel

Note: Specifications, materials, prices, terms, and delivery are subject to change without notice.

Accuride

ACCURIDE INTERNATIONAL INC.

12311 Shoemaker Avenue
 Santa Fe Springs, CA 90670
 TEL (562) 903-0200
 FAX (562) 903-0208
 www.accuride.com

Manufacturing, Engineering, and Sales
 United States • Germany • Japan • Mexico • United Kingdom