

APPLICATIONS: Electronic equipment mounted to moveable chassis. Use Model CC11 whenever wide cable management is required for single or multi-layered ribbon or bundle wire.

Wide Cable Carrier
For Heavy Duty Cable Installations

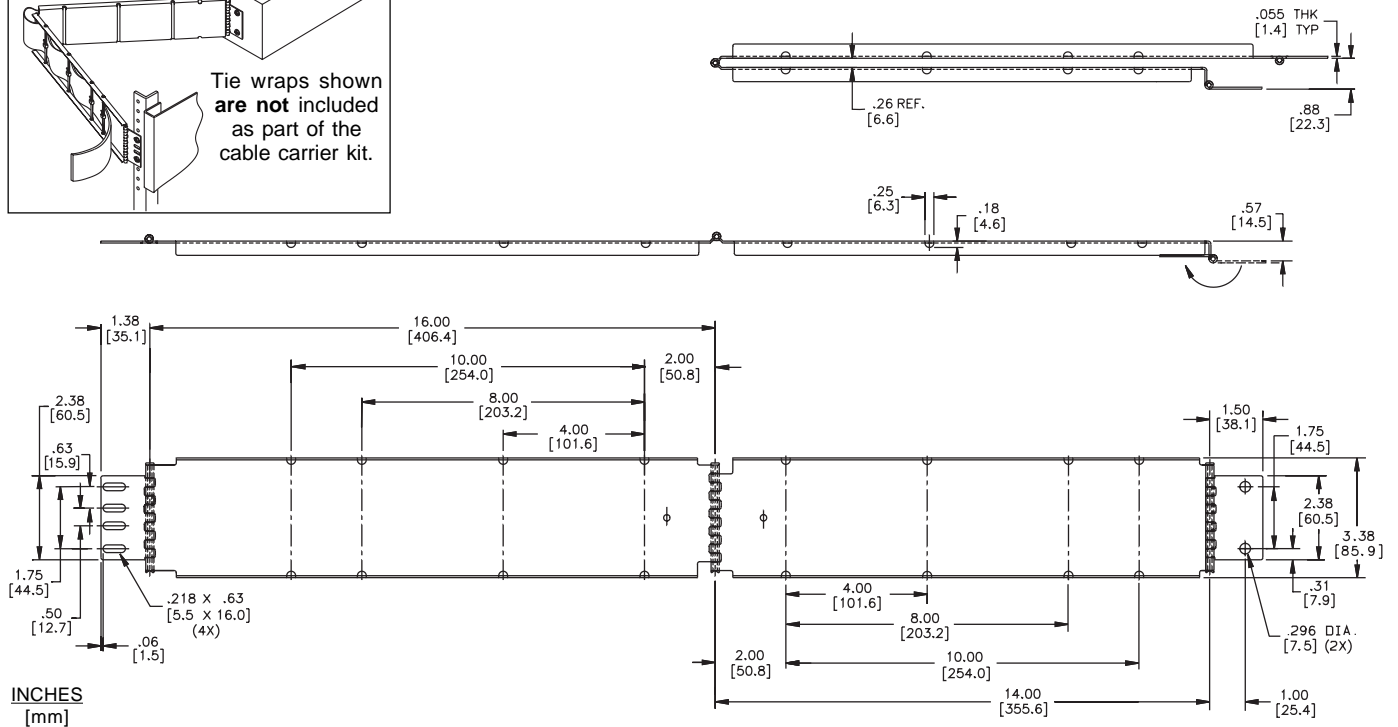
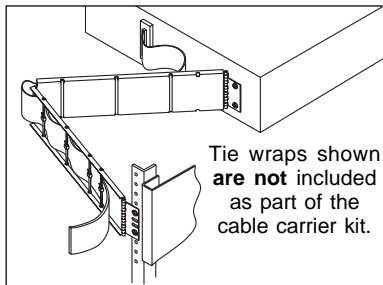

Installation Instructions

1. Install chassis into EIA rack.
2. Fasten rear cable carrier bracket with (customer supplied) #10 X 32 screws to EIA rack. For adjustment purposes, screw the back brackets on loosely.
3. Locate the front cable carrier bracket at the back of the chassis and attach cable carrier bracket with (customer supplied) #10 X 32 screws.
4. Check cable carrier alignment by opening and closing the chassis. Adjust position until movement is smooth.
5. Tighten screws and attach cable to complete installation.

Packaging

Distributor (D) Pack: Packaged 10 each per box. Polybag includes one cable carrier and installation sheet.

Bulk Pack: Packaged 10 each per box.

Ordering Instructions

To order cable carrier CC11 specify the following:

Total Quantity Required 10 Each
 Cable Carrier Model Number CC11
 Cable Carrier Finish (Electro-zinc plating) -C
 Optional Polybag Packaging D

Top View

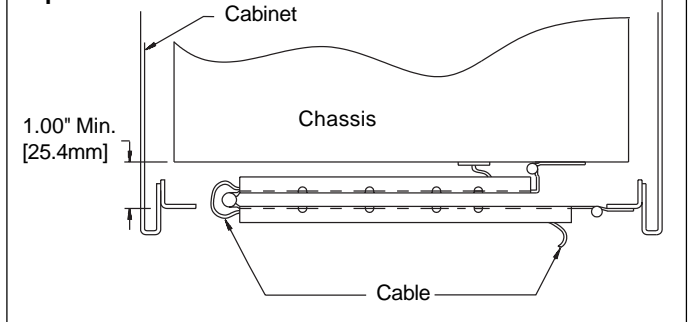

Top View

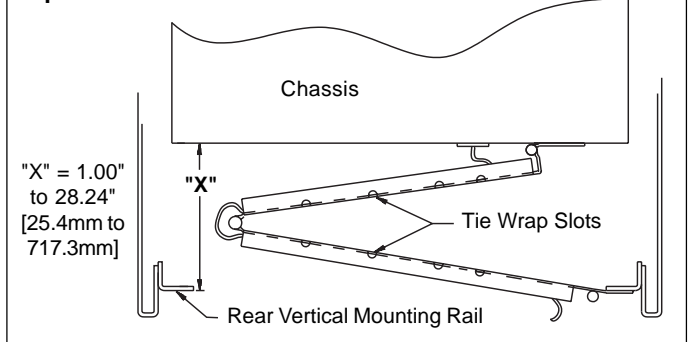

Specifications

Cable Carrier Members: Cold rolled steel
 Cable Carrier Finish: Bright electro-zinc plating

NOTE: Specifications, materials, prices, terms, and delivery are subject to change without notice.

APPLICATIONS: Electronic equipment mounted to moveable chassis. Use Model CC9 whenever cable management is required for bundle wire.

Cable Carrier
With Quick Disconnect

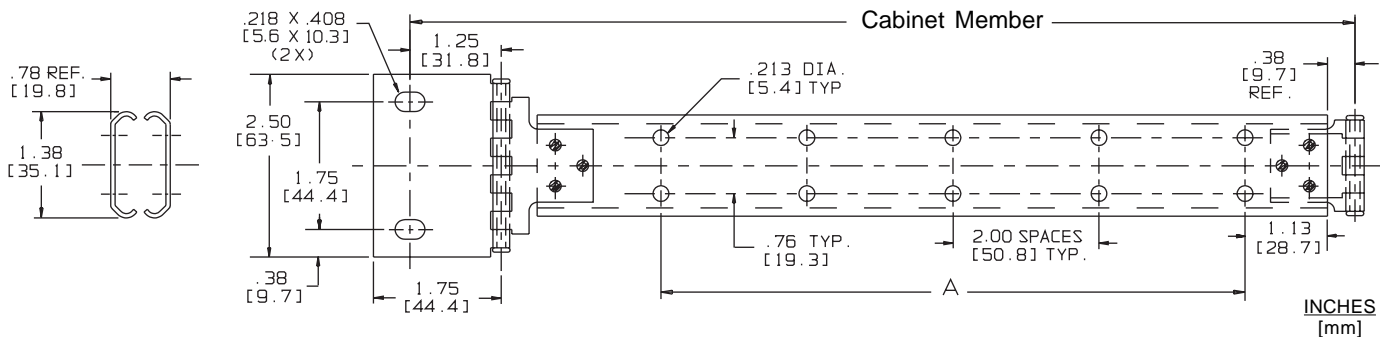
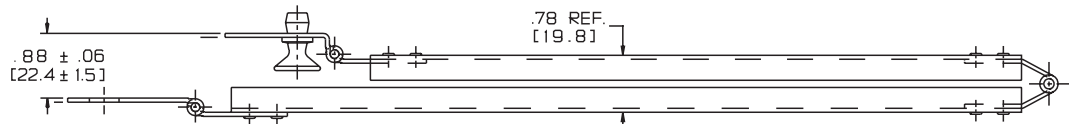
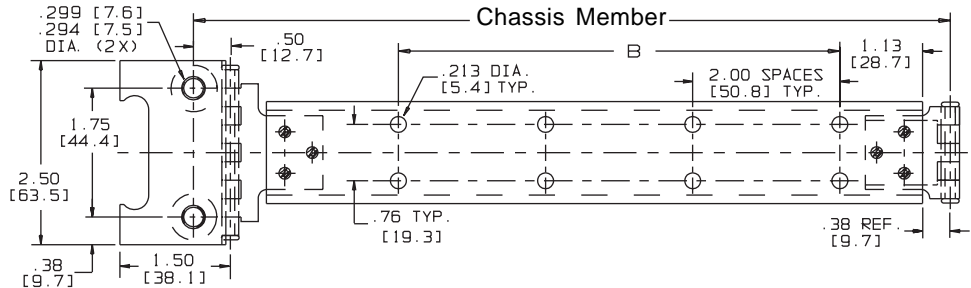
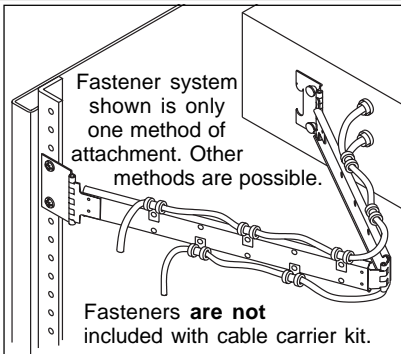

INCHES
[mm]

Installation Instructions

1. Install chassis into EIA rack.
2. Fasten rear cable carrier brackets with #10 X 32 screws (customer supplied) to EIA rack. For adjustment purposes screw the back brackets on loosely.
3. Locate the front cable carrier bracket at the back of the chassis and parallel to rear bracket. Drill two 5/16" (.313") holes in chassis and attach cable carrier bracket with "quick disconnect" fasteners. Fasteners will withstand 100 lbs. [45.5 kg.] of tension load and 250 lbs. [113.4 kg.] in shear.
Note: PUSH knobs to connect; PULL knobs to disconnect.
4. Check cable carrier alignment by opening and closing the chassis. Adjust position until movement is smooth.
5. Tighten screws and attach cable to complete installation.

Packaging

Distributor (D) Pack: Both lengths are packaged 10 each per box. Polybag includes one cable carrier and installation sheet.

Bulk Pack: Both lengths are packaged 15 each per box.

Specifications

Cable Carrier Members: Cold rolled steel
Cable Carrier Finish: Bright electro-zinc plating

NOTE: Specifications, materials, prices, terms, and delivery are subject to change without notice.

Ordering Instructions

To order cable carrier CC9 specify the following:

Total Quantity Required 10 Each CC9 -1 -C D
Cable Carrier Model Number _____
Cable Carrier Length (See chart) _____
Cable Carrier Finish (Electro-zinc plating) _____
Optional Polybag Packaging _____

Model	Extension	Cabinet Member	Chassis Member	Number of Spaces "A"	Number of Spaces "B"
CC9-1	23.00 [584.2]	14.28 [362.7]	11.63 [295.4]	4	3
CC9-2	29.00 [736.6]	16.75 [425.5]	14.13 [358.9]	6	5