

FH-M3x8~10mm PEM studs
at 4 locations in tray for fan fixing
OPTION is to install 4 x S-M3-2
PEM nuts into flange of fan

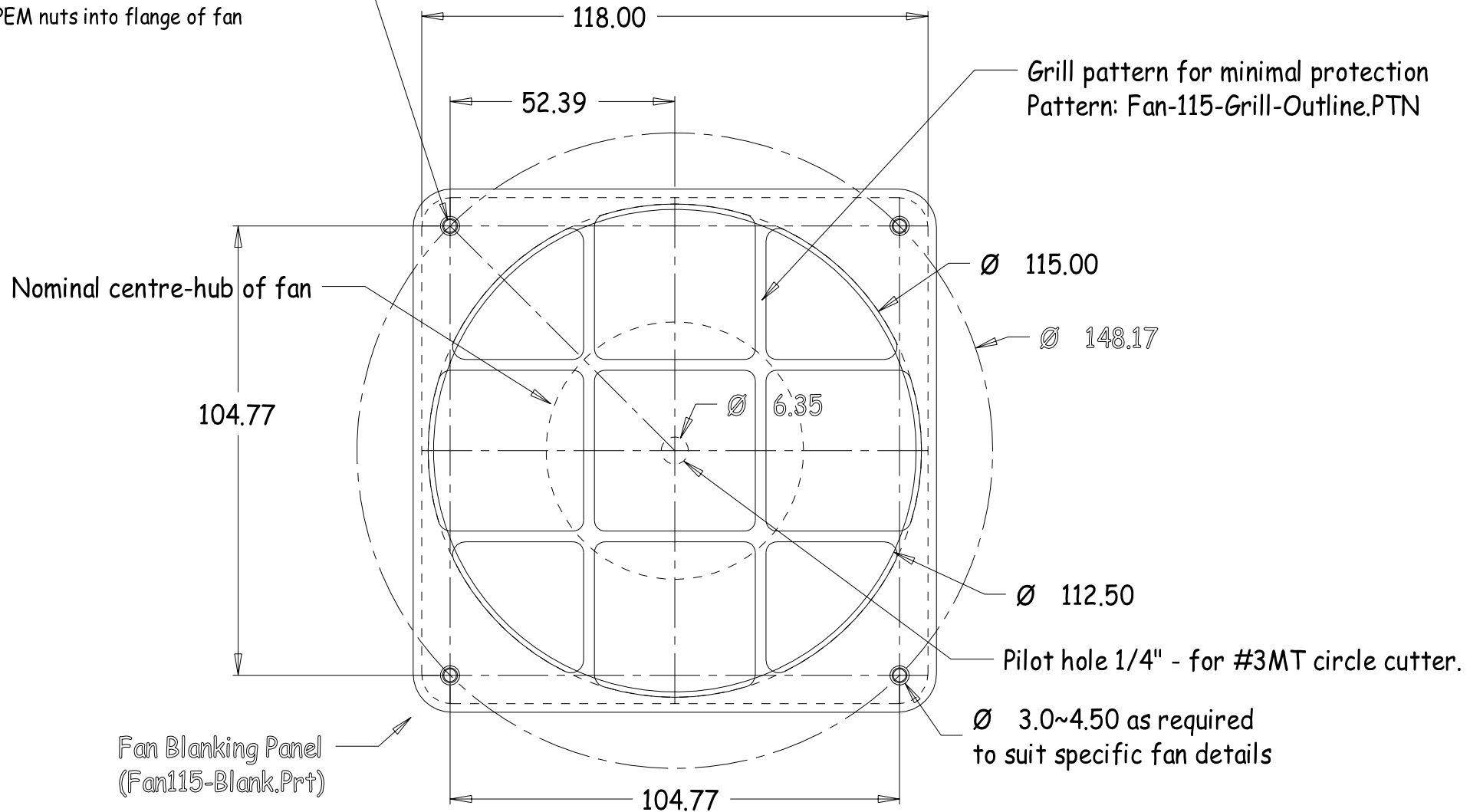

Typical fans include:

Sanyo - 109S089 (230Vac-50Hz-0.06A) 5 blade
ball-bearing - 1" thick - alloy-body - impedance protected.

MATERIAL
ALLOY
EST. AREA mm
EST. WEIGHT kg
EST. PERIPHERY EXT: mm
TOT: mm
TOLERANCE
0-100mm ±0.1mm
100-250mm ±0.25mm
250-500mm ±0.5mm
500-1000mm ±1.0mm
> 1000mm ±1.5mm
BS1474:1987 APPLIES UNLESS OTHERWISE SPECIFIED
JOB No.

Modular Systems P.O. BOX 38-828, WELLINGTON, NEW ZEALAND TELEPHONE : (64-4) 5687 277 FACSIMILE : (64-4) 5685 161	CUSTOMER : CASA Modular Systems Ltd	SIZE	DRAWING Reference No.	ISSUE
	DESCRIPTION : 115mm Dia. Axial Fan Fixing Details			
DRAWN : AWD	DATE :	APPROVED : ?	DWG. SCALE : 1:1	© COPYRIGHT : CASA Modular Systems 1996 ALL RIGHTS RESERVED