

ACCESSORY GUIDE

		FLIGHT II 60	FLIGHT II 80	SPRINT DC	SPRITE DC	FLIGHT II 90	FLIGHT II 120	WHISPER DC	MUFFIN XL DC	GALAXY DC	MAJOR DC	PATRIOT DC	BISCUIT DC	SPRITE	WHISPER	WHISPER XL	MUFFIN XL	MAJOR	PATRIOT	FEATHER	CARAVEL	TARZAN	BISCUIT	MB5100	MB9100	MB9200	MB9300		
FILTERS																													
Replacement Filter	272228																												
Replacement Filter	272229																												
Replacement Filter	272231																												
Replacement Filter	272232																												
Filter Assembly	477712																												
Filter Assembly	551590																												
Filter Guard Assembly (30 PPI)	557239																												
Filter Guard Assembly (45 PPI)	557240																												
Filter Guard Assembly (30 PPI)	554141																												
Filter Guard Assembly (45 PPI)	554142																												
Filter Guard Assembly (30 PPI)	557218																												
Filter Guard Assembly (45 PPI)	557219																												
Filter Guard Assembly (30 PPI)	554148																												
Filter Guard Assembly (45 PPI)	554149																												
GRILLES & GUARDS																													
Grille (Spiral)	476015																												
Grille (Expanded Metal)	477727																												
Grille Assembly	478031																												
Screen Guard	550214																												
FINGER GUARDS																													
Finger Guard (Metal)	476042																												
Finger Guard (Metal)	476136																												
Finger Guard (Metal)	476143																												
Finger Guard (Metal)	476323																												
Finger Guard (Metal) Rim Mount	476646																												
Finger Guard (Metal) Panel Mount	476651																												
Finger Guard (Metal)	477626																												
Finger Guard (Metal)	550272																												
Finger Guard (Plastic)	550481																												
Finger Guard (Plastic)	550648																												
Finger Guard (Plastic)	551147																												
Finger Guard (Plastic)	550651																												
Finger Guard (Metal)	551199																												
Finger Guard (Metal)	552934																												
Finger Guard (Metal)	554172																												
Finger Guard (Metal)	572621																												
Finger Guard (Metal)	557216																												
MOUNTING CLIPS																													
Mounting Clips (Bag of 3)	476154																												
#6-32 Flush Mounting Clips	477663																												
#6-32 Standoff Mounting Clips	477670																												
#6-32 Mounting Clips	550113																												
Mounting Clips (Filter/Grille Assembly)	271016																												
PLUG & CORD SETS																													
Straight On Plug and Cord	428023																												
Right Angle Plug and Cord	428056																												
Straight On Plug and Cord	550440																												
Polarized Right Angle Plug and Cord	571064																												

ACCESSORIES

ACCESSORIES

Filter Assembly (Whisper XL DC, Muffin XL DC, Whisper, Whisper XL, Muffin, Muffin XL)

Part No. 551590

Consists of:

- 551463 Filter Frame
- 551494 Filter Element
- 551453 Mounting Brackets

Recommended cut-out 5.5" x 5.16"

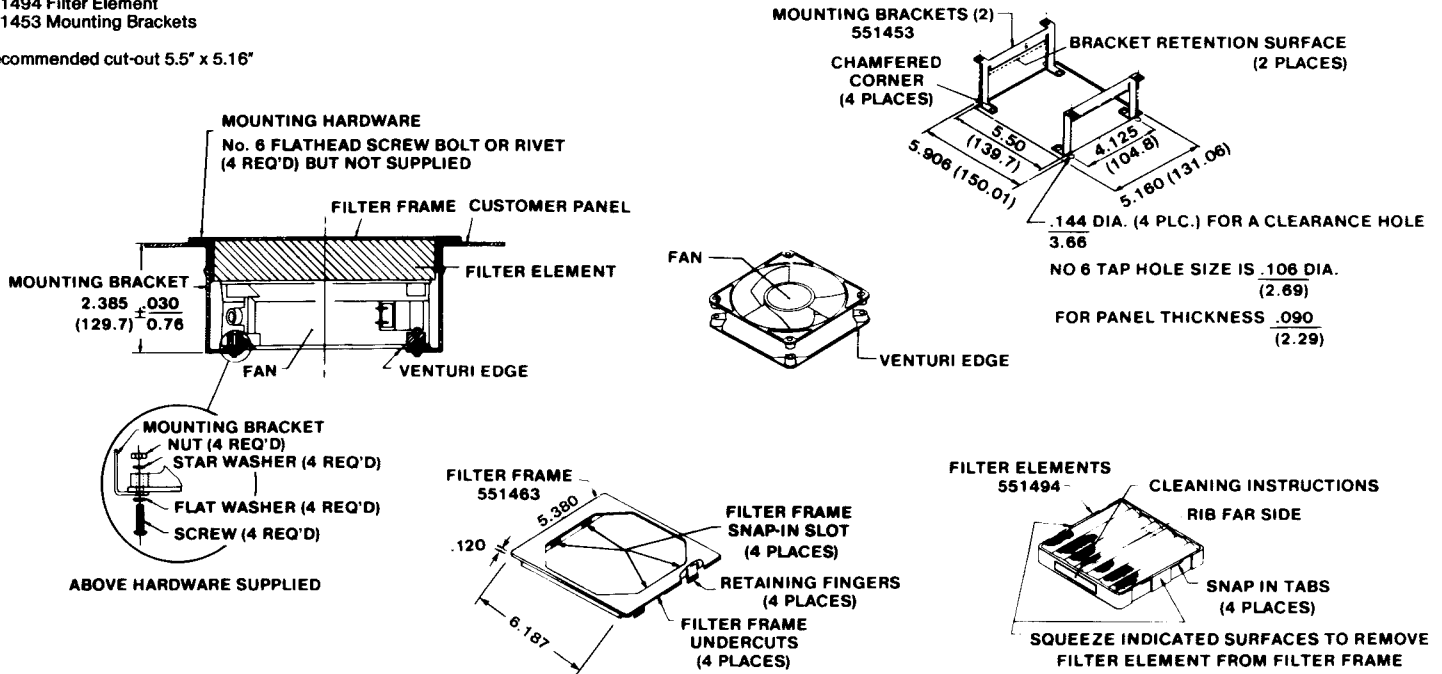

Note: Filters reduce airflow; i.e. a MX2A3's airflow would be reduced to about 87 CFM with P/N 551590 on fan's inlet at 115VAC, 60 Hz.

TOLERANCE: ± .015 (0.38) ON ALL LINEAR DIMENSIONS

Filter Guard Assembly (Flight 60)

Part No. 557239

- 30 PPI* Replacement Filter Element Part No. 557241 (pack of 5)
- Also available with 45 PPI Filter Part No. 557240
- 45 PPI Replacement Filter Element Part No. 557242 (pack of 5)
- Retainer and guard UL94V-0 plastic
- Filter element (media) polyurethane foam

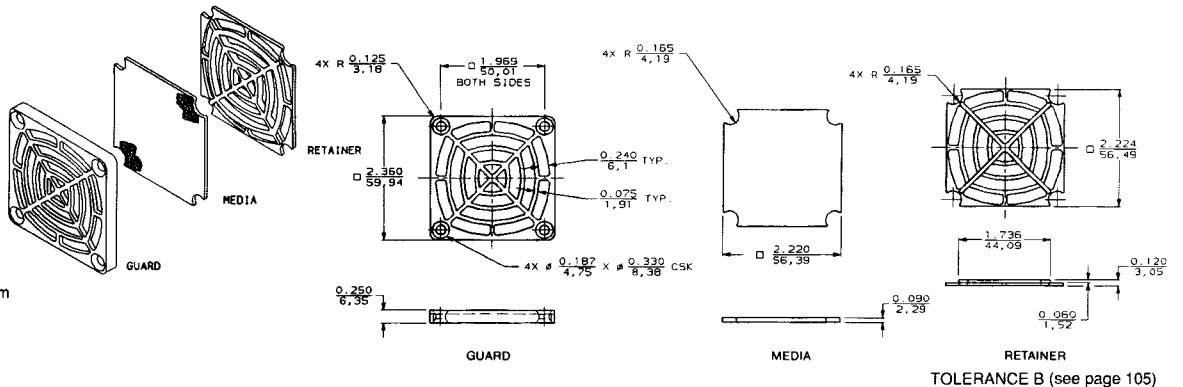

Note: Filters reduce airflow
* PPI denotes "pores per inch"

Filter Guard Assembly (Flight 80, Sprint DC, Sprite DC, Sprite)

Part No. 554141

- 30 PPI* Replacement Filter Element Part No. 554139 (Pack of 5)
- Also available with 45 PPI Filter Part No. 554142
- 45 PPI Replacement Filter Element Part No. 554140 (Pack of 5)
- Retainer and guard UL94V-0 plastic
- Replacement filter element (media) polyurethane foam

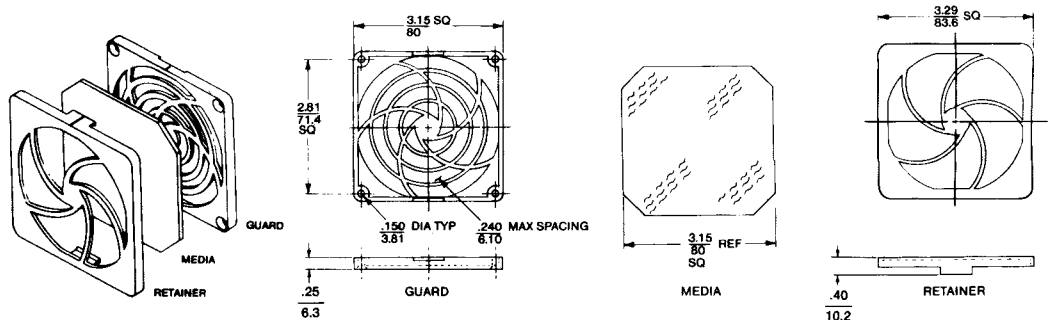

Note: Filters reduce airflow; i.e. a ST12A3's airflow would be reduced to about 25 CFM with P/N 554141 on fan's inlet at 12VDC.

* PPI denotes "pores per inch"

TOLERANCE B (see page 105)

Filter Guard Assembly (Flight 90) Part No. 557218

30 PPI* Replacement Filter Element
Part No. 557220 (pack of 5)
Also available with 45 PPI Filter
Part No. 557219
45 PPI Replacement Filter Element
Part No. 557221 (pack of 5)
Retainer and guard UL94V-0 plastic
Filter element (media) polyurethane foam

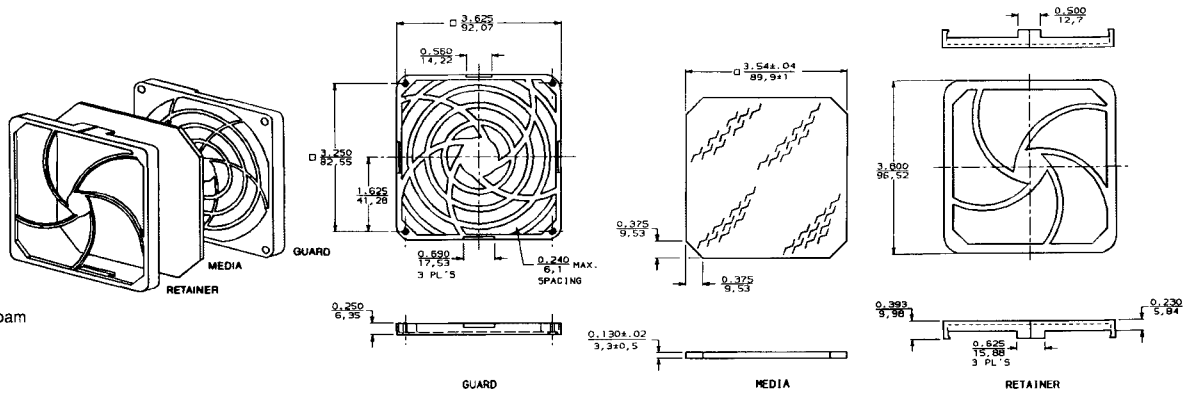

Note: Filters reduce airflow
* PPI denotes "pores per inch"

TOLERANCE B (see page 105)

Filter Guard Assembly (Flight 120, Muffin DC, Whisper XL DC, Muffin XL DC, Whisper, Whisper XL, Muffin, Muffin XL) Part No. 554148

30 PPI* Replacement Filter Element
Part No. 554146 (Pack of 5)
Also available with 45 PPI Filter
Part No. 554149
45 PPI Replacement Filter Element
Part No. 554147 (Pack of 5)
Retainer and guard UL94V-0 plastic
Replacement filter element (media)
polyurethane foam

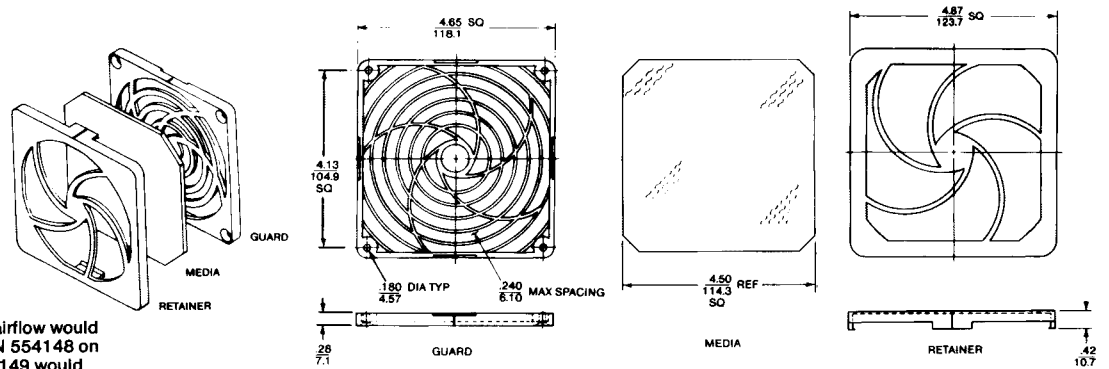

Note: Filters reduce airflow; i.e. a MX2A3's airflow would be reduced to about 75 CFM with P/N 554148 on fan's inlet at 115VAC, 60 Hz. P/N 554149 would reduce airflow to about 68 CFM.

*PPI denotes "pores per inch"

TOLERANCE B (see page 105)

Filter Assembly (Whisper, Muffin) Part No. 477712

Consists of:
476000 Filter Frame
271018 Washable Filter Element
271016 Mounting Clip (2)
Installation Instructions

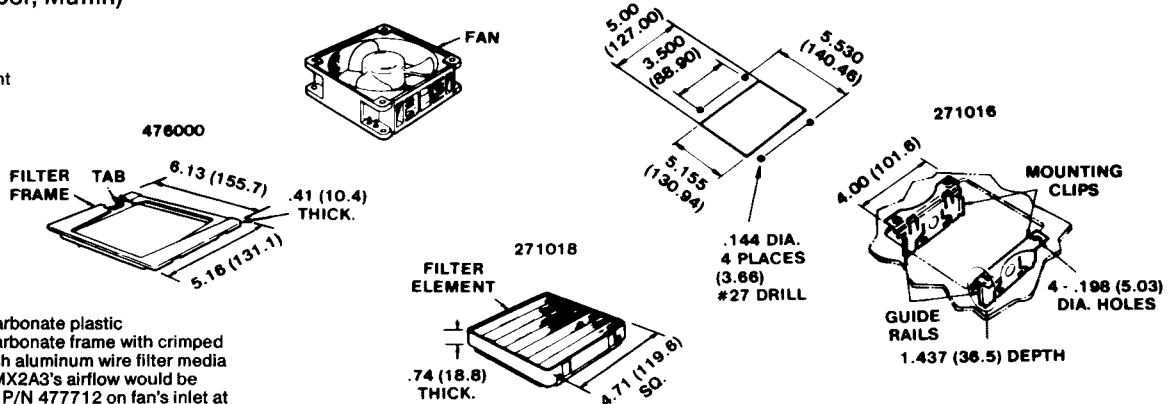

Materials: 476000 Black polycarbonate plastic
271018 Black polycarbonate frame with crimped
18 x 14 mesh aluminum wire filter media

Note: Filters reduce airflow; i.e. MX2A3's airflow would be reduced into about 82 CFM with P/N 477712 on fan's inlet at 115VAC, 60 Hz (UP).

TOLERANCE A (see page 105)

Grille Kit (Whisper, Muffin) Part No. 478031

Consists of:
476015 Grille (Spiral)
271016 Mounting Clip (2)
Installation Instructions

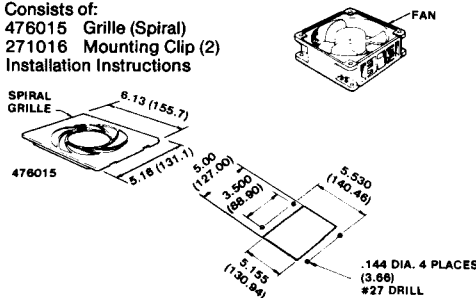

Materials: Grille—High Impact Polycarbonate Plastic
Clips—.020 (0.5) Thick Spring Steel, black phosphate finish

TOLERANCE: ±.015 (0.38) ON ALL LINEAR DIMENSIONS

Metal Grille (Whisper, Muffin) Part No. 477727

Expanded aluminum mesh - snaps onto fan venturi with use of Part No. 271016 mounting clips. (2 REQ'D)

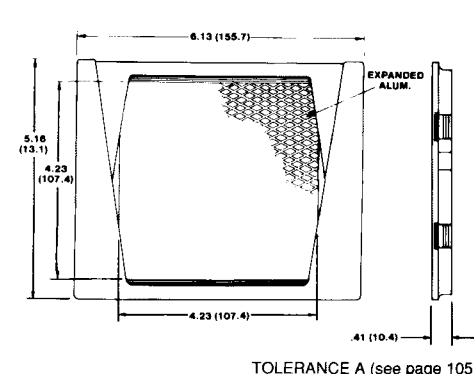

TOLERANCE A (see page 105)

Screen Guard (Flight 120, Muffin DC, Whisper XL DC, Muffin XL DC, Whisper, Whisper XL, Muffin, Muffin XL) Part No. 550214

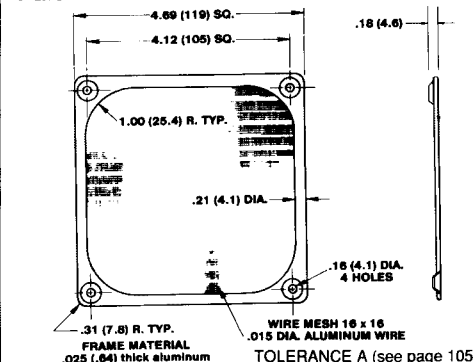

TOLERANCE A (see page 105)

Finger Guard (Biscuit DC, Biscuit)

Part No. 477626

.030 (.76) thick type 302 stainless steel. Screws onto outlet of blower with (2) 8-32 machine screws (not supplied)

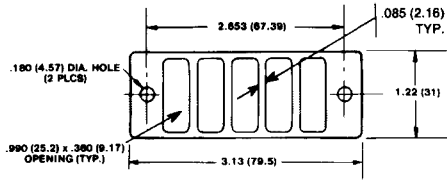

TOLERANCE A (see below)

Finger Guard (Tarzan)

Part No. 476136

Made of steel wire finished in nickel chrome

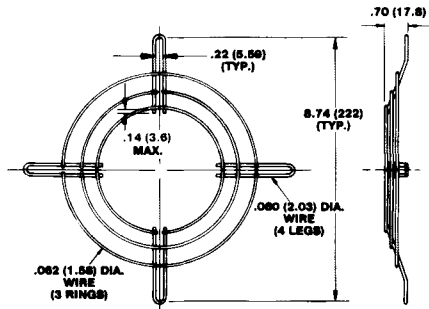

TOLERANCE B (see below)

Finger Guard (Caravel)

Part No. 476323

Made of steel wire finished in bright zinc. Mounts using #8 machine screws in the 4 legs equally spaced on 9.688 (246.1) dia.

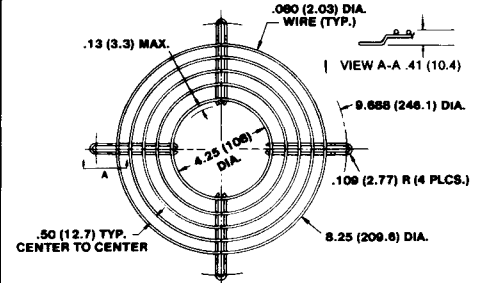

Note: Also available meeting UL .250 spacing. Call factory for specifications on P/N 555985

TOLERANCE B (see below)

Mounting Clip (Feather)

Part No. 476154 (set of 3)

Used with #4 machine screws. Three clips packed in a bag.

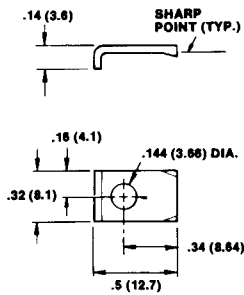

Material: .048 (1.24) thick steel, zinc plated

TOLERANCE B (see below)

Guard Mounting Clips (Feather)

Part No. 476649

For flush mount of fan onto customer panel, holding flush mount guard no. 476651 to panel. See page 75 for installation details

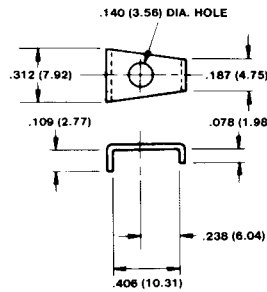

TOLERANCE B (see below)

Mounting Clips (Major DC, Patriot DC, Whisper, Muffin, Major, Patriot)

Part No. 477663 (Flush)

477670 (Standoff)

Fits over .25/6.35 mounting flanges of above fans

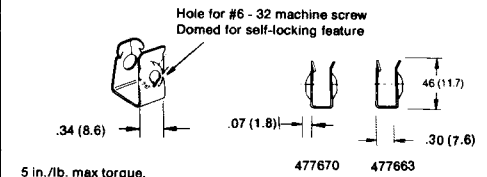

5 in./lb. max torque.

Material: .017 (.43) thick tempered spring steel
Finish: Black phosphate with oil dip

TOLERANCE B (see below)

Mounting Clips (Whisper XL DC, Muffin XL DC, Whisper XL, Muffin XL)

Part No. 550113

Fits over mounting boss of above fans

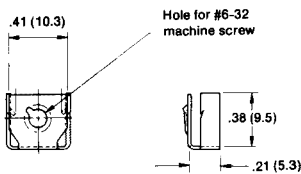

5 in./lb. max torque.

Material: .017 (.43) thick tempered spring steel
Finish: Black phosphate with oil dip

TOLERANCE B (see below)

Plug & Cord (Sprite DC, Sprite, Whisper XL, Muffin XL, Skeleton, Major, Patriot, Caravel, Tarzan, Biscuit)

Part No. 550440

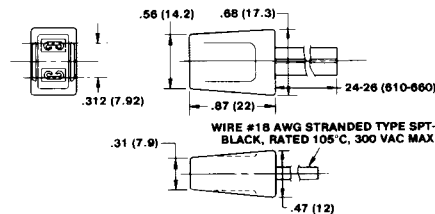

UL File No. E42397
GUIDE ZPFW2 Wiring Harness
CSA File No. LR45371

TOLERANCE A (see below)

Plug & Cord (Feather)

Part No. 428023

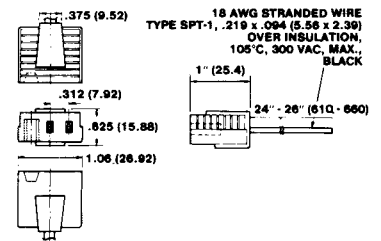

UL File No. E42397 Guide ZPFW2 Wiring Harness

TOLERANCE A (see below)

Plug & Cord (Sprite DC, Galaxy DC, Whisper XL DC, Muffin XL DC)

Part No. 571064

Polarized with red tracer

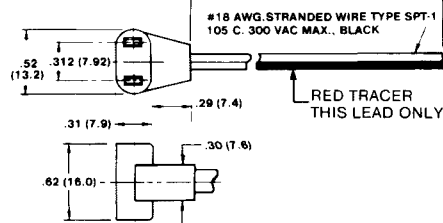

TOLERANCE B

Plug & Cord (Sprite DC, Sprite, Whisper, Whisper XL, Muffin, Muffin XL, Skeleton, Major, Patriot, Caravel, Tarzan, Biscuit)

Part No. 428056

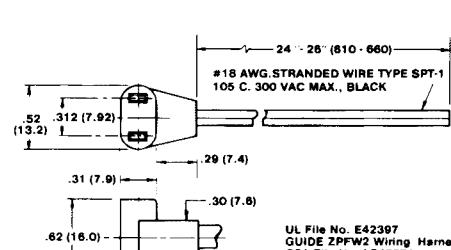

UL File No. E42397
GUIDE ZPFW2 Wiring Harness
CSA File No. LR45371

TOLERANCE B

TOLERANCE A: .XX = ± .03 (0.8)
.XXX = ± .010 (0.25)

TOLERANCE B: .XX = ± .05 (1.3)
.XXX = ± .015 (0.38)