

M-Track | Features

Light Duty Actuators

Key Features

- Compact size
- Efficient design
- Easy to use and install

Standard Models

M1



How To Select

Step 1 – Determine Load and Stroke length requirements

Use the Quick Selection guide to identify the model that will provide the load capacity and stroke length needed for your application.

Step 2 – Identify motor type and voltage

Select DC motor and motor voltage.

Step 3 – Confirm Speed and Current draw requirements

Using the charts provided, confirm that unit speed and current draw is appropriate for the intended use.

Step 4 – Confirm the application Duty Cycle

At full load capacity, actuators have a 25% duty cycle. Duty cycle is the amount of ‘on-time’ compared to cooling time. A unit that runs for 15 seconds should be off for 45 seconds.

Important Unit Restrictions

Side loading and shock loads must be considered in actuator applications. Side loading and cantilevered mounting should be eliminated through proper machine design. Side loading will dramatically reduce unit life. While actuators can withstand limited shock loads, it is recommended that shock loading be avoided wherever possible. (See page 35)

Step 5 – Unit Options

M-Track units include end-of-travel limit switches as a standard feature. For positional feedback, a 10K ohm potentiometer can be factory installed. The changing potentiometer value provides unit movement feedback for units that are not visible to the machine operator.

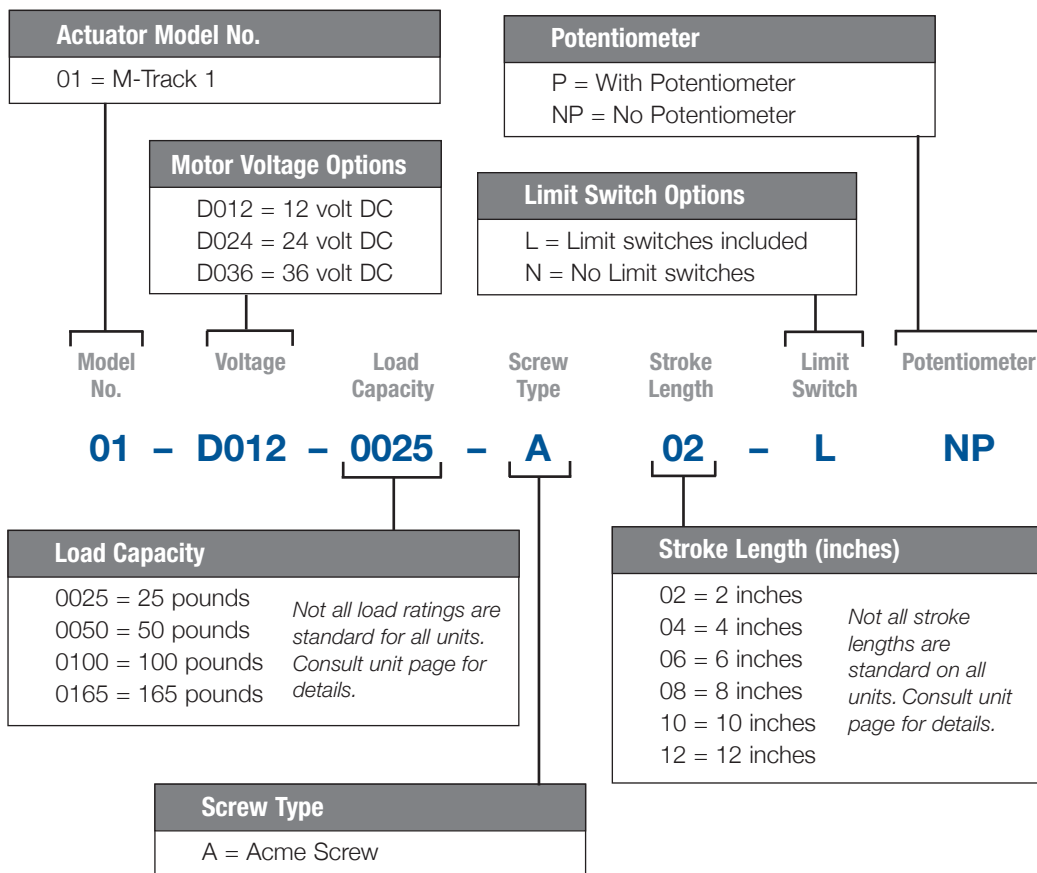

M-Track | 1

DC Motor Acme Screw

Up to 165 lb. Rated Load

Up to 1.75 in./sec. Travel Speed



M-Track 1 compact units are completely self-contained and sealed to allow use in small spaces without sacrificing power or capability. The load and length capabilities provide solutions for a diverse range of intermittent duty applications.

Functionally, M-Track 1 actuators are easily interchanged with comparable size hydraulic or pneumatic cylinders on intermittent duty applications. The actuator provides consistent, repeatable performance even for applications with operating conditions including temperature extremes, high humidity, or significant dust.

Features

- An Acme Screw drive delivers up to 165 pounds of force at a minimum extension rate of 0.25 inches per second
- The aluminum zinc alloy housing resists corrosion and provides protection from dirt, dust and humidity
- The M-Track 1 has a temperature operating range of -15° to $+150^{\circ}$ F
- Standard stroke lengths of 2, 4, 6, 8, 10, 12 inches are available
- Internal limit switches automatically shut off the unit at end of stroke
- Optional potentiometer can provide positional location feedback
- IP65 capable on request

Typical Applications

Light load and short distance applications such as:

- Valve and vent adjustments
- Light weight tilt or lift positioning
- Vise and clamp operations

Specifications

Load Capacity	25 pounds	50 pounds	100 pounds	165 pounds
Speed at Full Load	1.75 in/sec	0.85 in/sec	0.45 in/sec	0.25 in/sec
Input Voltage	12 or 24 volt DC for all models (36 volt optional)			
Static Load Capacity	300 pounds for all models			
Stroke Length	2, 4, 6, 8, 10 and 12 inches for all models			
Clevis Ends	6.4 mm diameter			
Duty Cycle	25% for all models			
Operation Temperature Range	-15° F to $+150^{\circ}$ F for all models			
Limit Switch	Fixed end of stroke limit switches standard for all units			
Potentiometer	10K, 10 turn pot optional on all units			
Restraining Torque	20 inch pounds for all units			

Performance Curves

Current vs Load

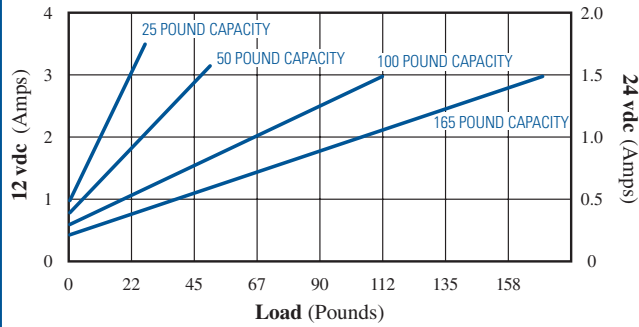

Speed vs Load

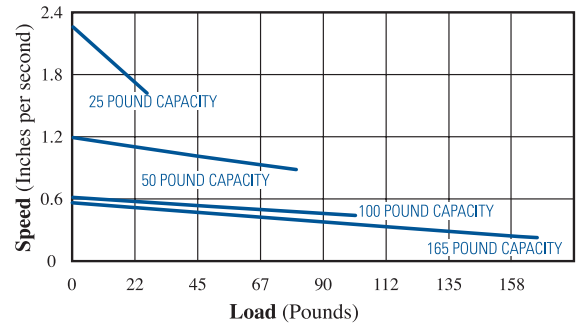

Dimensions

Stroke Length	2		4		6		8		10		12	
	in	mm	in	mm	in	mm	in	mm	in	mm	in	mm
Retracted Length (without POT sensor)	6.22	158	8.23	209	10.24	260	12.24	311	14.25	362	16.26	413
Retracted Length (with POT sensor)	7.56	192	9.57	243	11.57	294	13.58	345	N/A	N/A	N/A	N/A

With Limit Switches and Potentiometer

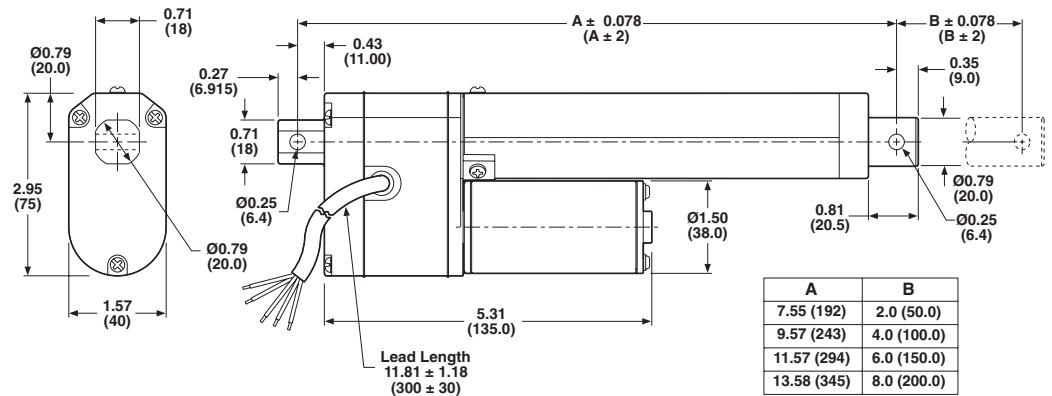

With Limit Switch Only

