

RB-35PM-0ED3

TITLE

EXTERNAL DRAWING

DRAWING NUMBER

UNIT	mm
SCALE	1/1
DESIGN	
DRAWING	K. MAENO
INSPECTED	S. HASHIMOTO
DATE	25. AUG. '97
SECTION	DESIGNING ON SALE

ALTERATION

△	1997. 9. 2	K. MAENO
△		
△		

NOTE

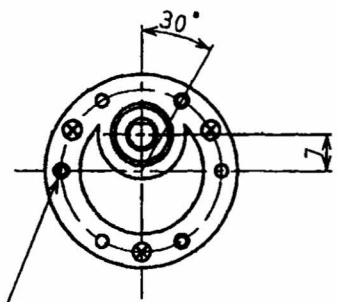
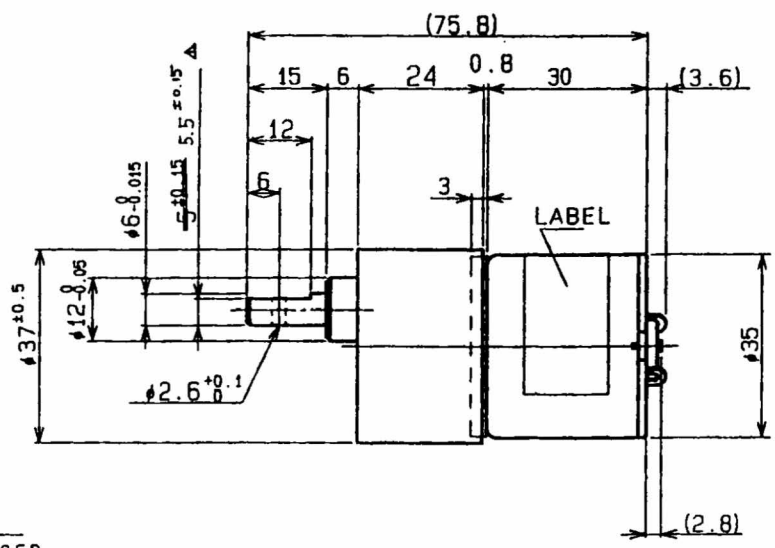

3-M3 (P=0.5) DEPTH 4MAX
ON $\phi 31 \pm 0.2$ CIRCLE, EQUALLY SPACED

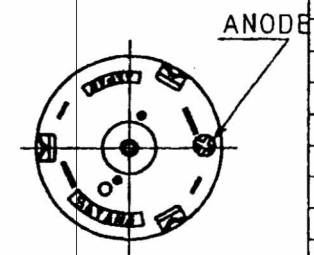

- NOTE 1. OUTPUT SHAFT MUST NOT LOCKING
2. GENERAL TOLERANCE: ± 0.5 BELOW 10
 ± 0.7 ABOVE 10
3. SPECIFICATION OF LABEL
3-1 SHAPE AND SIZE

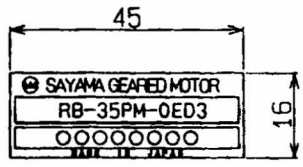

3-2 LOT No.

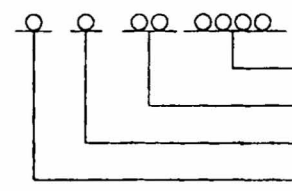

- REDUCTION RATIO
THE MONTH OF MANUFACTURE
THE END OF MANUFACTURE YEAR (JAPANESE YEAR)
SPECIFICATION NO.

4. THE POSITION OF MODEL NAME LABEL SHOULD BE MOTOR SIDE, THEREFORE THIS POSITION OF MODEL NAME LABEL IS FOR YOUR REFERENCE ONLY.

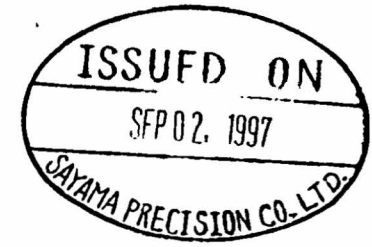

納品 1102-2

RB-35PM-0ED3-DWG.jpg