

TO-3

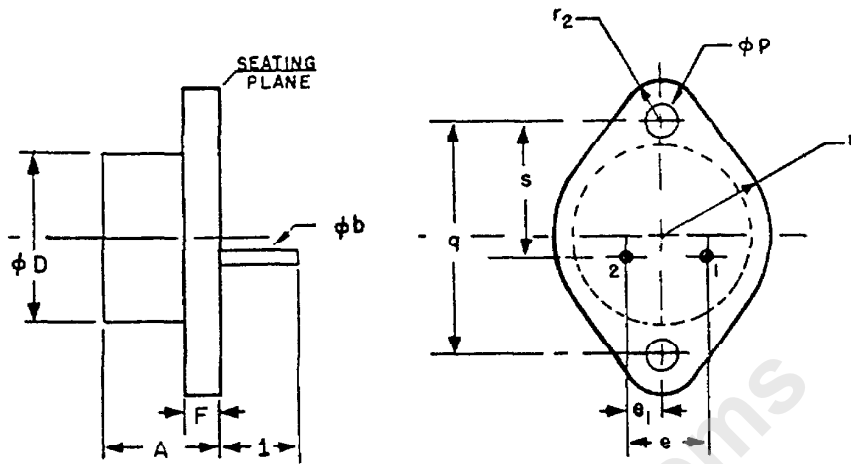

SYMBOL	INCHES		MILLIMETERS		NOTES
	MIN.	MAX.	MIN.	MAX.	
A	.250	.450	6.35	11.43	
ϕb	.038	.043	.97	1.09	2
ϕD		.875		22.23	
e	.420	.440	10.67	11.18	
e_1	.205	.225	5.21	5.72	
F		.135		3.43	
1	.312		7.92		2
ϕp	.151	.161	3.84	4.09	
q	1.177	1.197	29.90	30.40	
r_1		.525		13.34	
r_2		.188		4.78	
s	.655	.675	16.64	17.15	1

NOTES:

1. THESE DIMENSIONS SHOULD BE MEASURED AT POINTS .050" (1.27 MM) TO .055" (1.40 MM) BELOW SEATING PLANE. WHEN GAGE IS NOT USED, MEASUREMENT WILL BE MADE AT SEATING PLANE.
2. TWO LEADS.

THIS OUTLINE DOES NOT MEET THE MINIMUM CRITERIA ESTABLISHED BY JS-10 FOR REGISTRATION

4.6.2