

T0-39

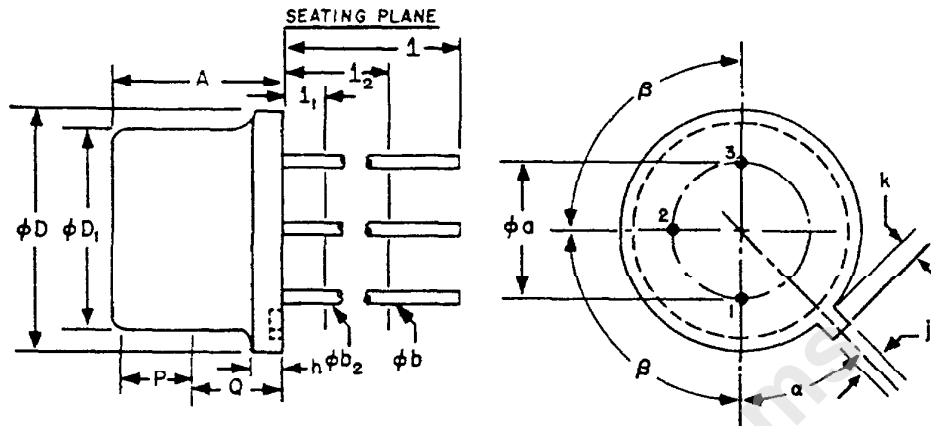

SYMBOL	INCHES		MILLIMETERS		NOTES
	MIN.	MAX.	MIN.	MAX.	
ϕa	.190	.210	4.83	5.33	
A	.240	.260	6.10	6.60	
ϕb	.016	.021	.406	.533	2
ϕb_2	.016	.019	.406	.483	2
ϕD	.350	.370	8.89	9.40	
ϕD_1	.315	.335	8.00	8.51	
h	.009	.125	.229	3.18	
j	.028	.034	.711	.864	
k	.029	.040	.737	1.02	3
l	.500		12.70		2
l_1		.050		1.27	2
l_2	.250		6.35		2
P	.100		2.54		1
Q					4
α	45° NOMINAL				
β	90° NOMINAL				

NOTES:

1. THIS ZONE IS CONTROLLED FOR AUTOMATIC HANDLING. THE VARIATION IN ACTUAL DIAMETER WITHIN THIS ZONE SHALL NOT EXCEED .010" (.254 MM).
2. (THREE LEADS) ϕb_2 APPLIES BETWEEN l_1 AND l_2 . ϕb APPLIES BETWEEN l_2 AND .5" (12.70 MM) FROM SEATING PLANE. DIAMETER IS UNCONTROLLED IN l_1 AND BEYOND .5" (12.70 MM) FROM SEATING PLANE.
3. MEASURED FROM MAXIMUM DIAMETER OF THE ACTUAL DEVICE.
4. DETAILS OF OUTLINE IN THIS ZONE OPTIONAL.

4.6.17