

June 1, 1943.

W. S. KEITH

2,320,871

ACORN TUBE SOCKET

Filed June 13, 1941

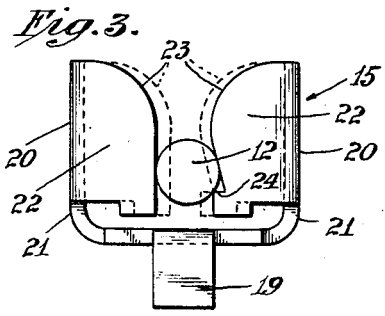
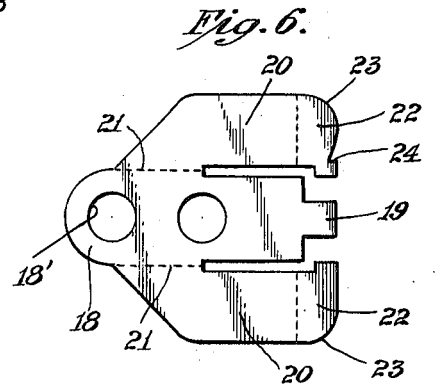
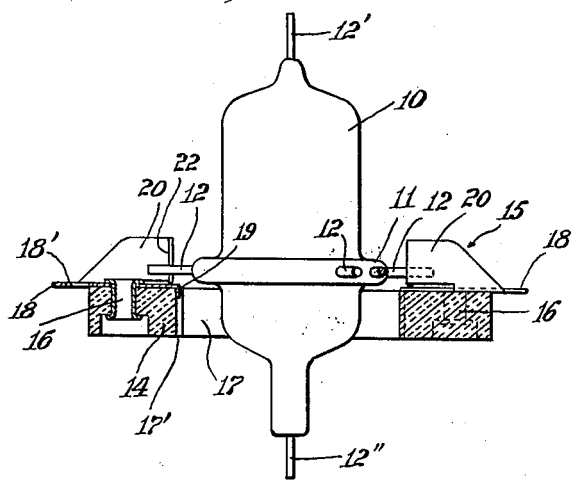
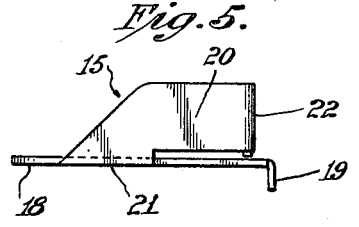
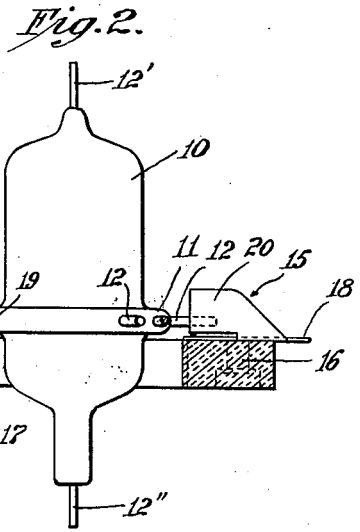
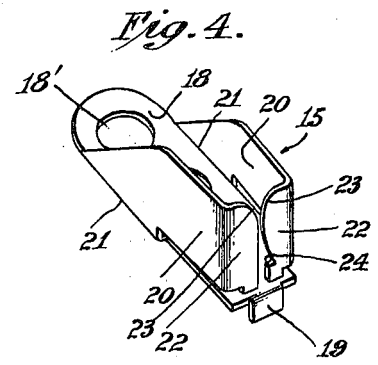
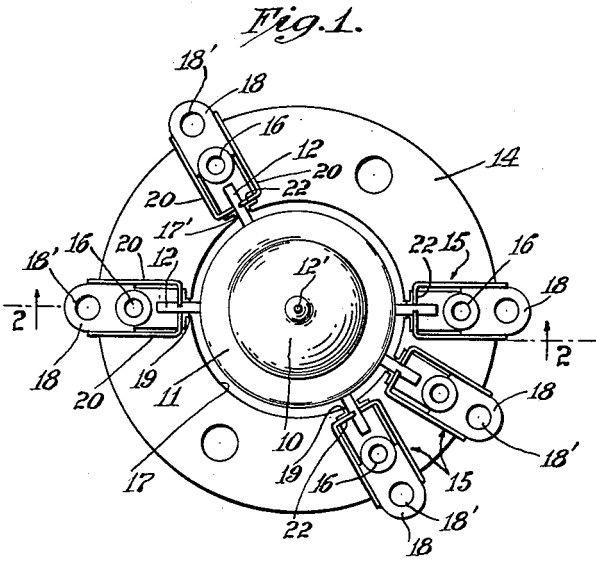

INVENTOR
Walton S. Keith
BY *[Signature]*
ATTORNEY

UNITED STATES PATENT OFFICE

2,320,871

ACORN TUBE SOCKET

Walter S. Keith, Long Island City, N. Y., assignor
to The Hammarlund Manufacturing Company,
Incorporated, New York, N. Y., a corporation of
New York

Application June 13, 1941, Serial No. 397,862

4 Claims. (Cl. 173—328)

This invention relates to sockets for the reception of a plug or tube provided with radially extending contact pins.

More particularly this invention relates to a socket for the support and connection of an electronic tube of the so-called "acorn" or ultra high frequency type.

For the employment of these tubes it is necessary that a socket afford not only a positive contact with the pins of the tube but also it is necessary that this contact be made at a comparatively sharply defined point so as to afford a current path of unchanging length, as well as providing comparatively low and constant effective capacity between the various contact structures. Likewise it is desirable that a socket for this purpose include means for automatically centering the tube, in order that an interchange of tubes will not result in a change of the effective length of the current path through the contacts and the contact pins.

Electronic tubes of the ultra high frequency type are usually provided with a peripheral ring-like structure in lieu of the usual base. This structure is usually situated at a point intermediate the ends of the tube and projecting there-through are a plurality of radially disposed contact pins of relatively small diameter. These pins may be held in position by the peripheral ring through which they project, thus avoiding the use of any insulating material other than the glass of which the tube itself is composed. Such pins are comparatively rigid and not easily bent out of the single plane in which they lie.

One form of socket which has been employed for the reception of an acorn tube consists of an annular ring of insulating material having suitable high resistance, low dielectric constant and low surface leakage. Around the periphery of this ring are located a number of contacts, also radially disposed, provided toward their inner ends with some clamping device into which the contact pins of the tube may enter and be held.

The sockets hitherto employed have been subject to several difficulties and defects. In general, the contact pin has made connection with the socket contact along a path of relatively great magnitude in a radial direction. It is to be understood that when dealing with ultra high frequency currents, a length of current path amounting to only a few millimeters may make an enormous difference in respect to the impedance presented to such currents and may cause undesirable alterations at these extremely high frequencies. Consequently, with sockets of

the type just described, the exact point at which the current passes from the tube pin to the socket contact is not a clearly defined one and accordingly the length of the current path may vary to a degree limited only by the radial length of such contact making elements. An especial difficulty encountered with sockets of this type is that the contact pin of the tube not only touches the socket contact portions designed to receive it, but also makes more or less imperfect contact with the base of the socket contact, or with some other portion of the contact, thus giving rise to further trouble with regard to the length of current path.

One object of this invention is to provide a socket of the character described which will be lighter and contain less solid dielectric than sockets hitherto used and which therefore will be cheaper to manufacture.

Another object of this invention is to provide a socket into which the tube prongs will snap and be firmly held so that the socket may be mounted in any desired position, even inverted without danger that the tube prongs will become loosened or the tube fall out of the socket, as may occur especially when the structure is subjected to vibration.

Another object of this invention is to provide a socket in which the total length of the current path from the conductor to the tube prong, when the tube is mounted in the socket, will be substantially reduced in length and will be maintained at a constant and comparatively sharply defined value.

Another object of this invention is to provide a socket in which the inter-contact capacity will be constant and comparatively low.

Yet another purpose of this invention is to provide a socket contact which will engage the tube prong in such fashion as to cut through any surface oxide or dirt which may be present upon the prong and thus will give rise to a contact of low effective impedance.

A further purpose of this invention is to provide means whereby an acorn tube socket will receive and make good contact with the tube pins even though such pins be somewhat bent out of a strictly radial position.

A still further purpose of the invention is to provide a socket in which the tube contact pin will make connection with the socket contact only over a portion of a single comparatively narrow plane situated at right angles to the radial direction in which this pin extends, thus keeping the total impedance between the conductor at-

tached to the socket and the tube pin constant to a very high degree.

Yet another object of this invention is to provide a socket wherein the contact between the tube pin and the socket contact member will be of extremely low and constant ohmic resistance.

In the drawing

Fig. 1 is a plan view showing a conventional acorn tube mounted in the socket of this invention.

Fig. 2 is a side elevation partly in section of the structures of Fig. 1 along the line 2—2.

Fig. 3 is a view in elevation of the inner end of a single contact with the tube prong in position, the dotted lines indicating the contact before entry of the prong.

Fig. 4 is a perspective view of the contact.

Fig. 5 is a side elevation of the contact.

Fig. 6 is a view of the contact flattened out so as to show all portions thereof lying in a single plane.

The tube 10 has a peripheral ring 11 from which project radially the terminal pins or wires 12 corresponding with the various elements of the tube. Additional terminal pins 12' and 12'' may be provided at the respective ends of the tube.

The socket has an insulating base 14 and a number of contacts 15 corresponding in number and arrangement with the tube pins. Each contact is secured to the base in a suitable manner for instance by a rivet 16. The base in this case has an opening 17 somewhat larger in diameter than the tube diameter, so that the tube will be supported completely out of contact with the base of the socket.

Each contact is formed of sheet metal of suitable characteristic preferably beryllium copper, silver plated for better surface conductivity, and has a foot 18 at the outer end through which the fastening device 16 is secured and a tongue 19 at the inner end overlapping the edge of the recess 17 and seated in groove 17' so as to prevent rotation of the contact. The contact has two resilient side arms 20, 20 formed integrally at 21, 21 with the central part of the contact. Each arm terminates in a jaw 22. These jaws project toward each other and have a V-shaped or rounded entrance 23 adapted to receive a tube pin. A notch or shoulder 24 is formed near the inner end of one or both of the jaws to hold the tube pin in place engaged between the jaws 22, 22 but situated above the tongue 19. Foot 18 is preferably provided with an aperture 18' near the end thereof, for the connection of a wire to the foot.

Into such contacts the tube pins can be readily and easily inserted and securely held in any position of the tube and socket, either horizontal, vertical or inclined and without danger of the tube working loose or falling out. The edges of the jaws are relatively sharp so that they cut into the surface of the tube pins removing any oxidation or dust and thus ensuring a perfect contact engagement.

It can be seen that even though the contact pins of the tube are accidentally bent somewhat in a direction so that they no longer lie in a single plane, yet the contacts of this socket will still grip any pin so bent at substantially a single point along its length. Likewise in case that one or more of the pins are bent laterally to a slight degree, as often is the case due to manufacturing tolerances, the contacts of this socket can adjust themselves to such pins if the degree of bending

is not too great. This ability to make such compensatory adjustment arises from the fact that the side arms of the contact, carrying the contact making jaws at their inner extremities, bend about the portions 21 which act somewhat as fulcrums and are located so far away from the jaws that the side arms possess considerable flexing ability or lateral play, in comparison with prior art contacts where the flexing occurs substantially at the points where the pin enters the contact. If the tube pins be considerably bent out of place, the tube may assume a position eccentric with respect to opening 17 in the center of the socket and suitable adjustments may then be made so as to secure equalization of the effective electrical length of the circuit including the contact and the tube pin.

It will be evident that, while there has been illustrated a socket for a tube having five radial prongs, it is possible to use a greater or lesser number of contacts and to dispose them in other positions relative to one another in accordance with the arrangement of radial prongs on the tube to be used.

It will be noted that the contacts of the socket are positively positioned so that each extends in a radial direction, since the action of the tongues 19 serves to prevent each contact from rotating about the rivet 16 used to secure it to the base, and thus serves to prevent the contacts from touching one another and to maintain a current path of substantially unchanging length for each tube prong.

For shielding purposes a suitably apertured metallic plate may be arranged to cover the bottom of the socket and additional shielding such as an outwardly projecting collar may extend from the plate along the sides of the tube passing therethrough, as well known in the art.

I claim:

1. In a socket for the reception of a tube having radially extending prongs, a contact comprising a base portion terminating in a tongue for locking to the socket, two longitudinally extending side wings extending upwardly from the base portion, each bent inwardly at one extremity so as to form a pair of opposed jaws lying in a single plane, one of said jaws having in the edge a notch with a bottom ledge substantially parallel to the base portion and with an outwardly tapered entrance portion, whereby said side wings flex about said base portion when said jaws are spread apart by the insertion of a prong therebetween and whereby the tapered entrance of said notch forces said inserted prong against said bottom ledge.

2. A prong receiving contact for use in high frequency circuits, including an elongated body formed in one piece of sheet metal and having two longitudinal slits therein so as to render said body trifurcated into three parallel and adjacent tines joined together at one end of said body, the two outer tines thereof being bent about their respective points of juncture with the central tine, so as to extend in planes lying respectively at right angles to said central tine, and so as to lie substantially parallel to each other, said outer tines also being bent inwardly near the respective free ends thereof so as to form coplanar jaws for making substantially a line contact with a connecting pin inserted between said jaws, whereby said jaws by their opening cause said outer tines to flex about the common point of juncture of the three tines.

3. A socket for tubes having a number of pins projecting outwardly from a central axis com-

prising an annular insulating base having an opening substantially in the central axis thereof and contacts secured to said base around the opening in the base, each contact having a central portion mounted on the upper surface of the base and terminating in a tongue embracing the rim of the opening, longitudinally extending and laterally resilient arms on opposite sides of the central portion terminating in jaws facing toward each other with a tapered entrance to a space between them and with their edges extending substantially at right angles to the upper face of the base, at least one of the jaws having a notch provided with a bottom ledge extending substantially parallel to said central portion of the contact so as to hold an inserted tube pin, said jaw being outwardly tapered toward said notch so as to force said pin against the ledge, said jaws being so arranged with respect to the

base that the pins of a tube may be simultaneously inserted in the respective contact jaws by aligning the pins with the spaces between the jaws of the contacts and pushing the tube into the opening in the base.

4. An acorn tube socket including a substantially annular base of insulating material and contacts mounted radially thereupon, each contact including a base portion affixed to said base and two side arms each formed integrally with and flexing about said base portion at a point near the outer end thereof, said arms being bent at their inner ends so as to form a pair of prong receiving jaws lying substantially in a single plane, whereby said jaws are capable of relatively great lateral movement due to the location of the point of flexure of said arms at a point relatively remote from said prong receiving jaws.

WALTER S. KEITH